

COSINE-100 NaI(Tl) Dark Matter Experiment: Testing DAMA's Claim for a Dark Matter Discovery

Jay Hyun Jo
Yale University

SLAC Experimental Seminar
March 26, 2019

Evidence of Dark matter

Cosmological observations give strong evidence of dark matter:

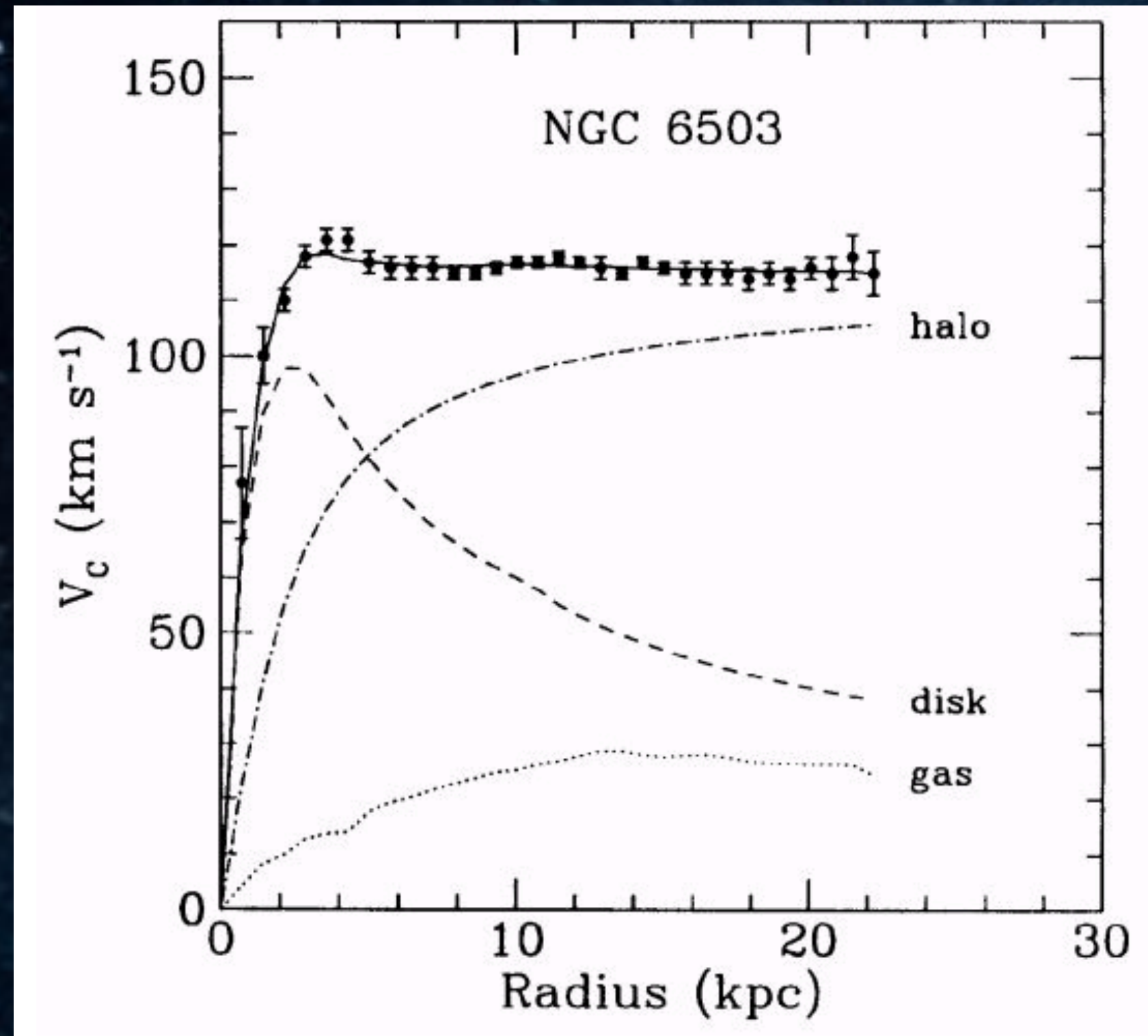

Galaxy rotation curves...

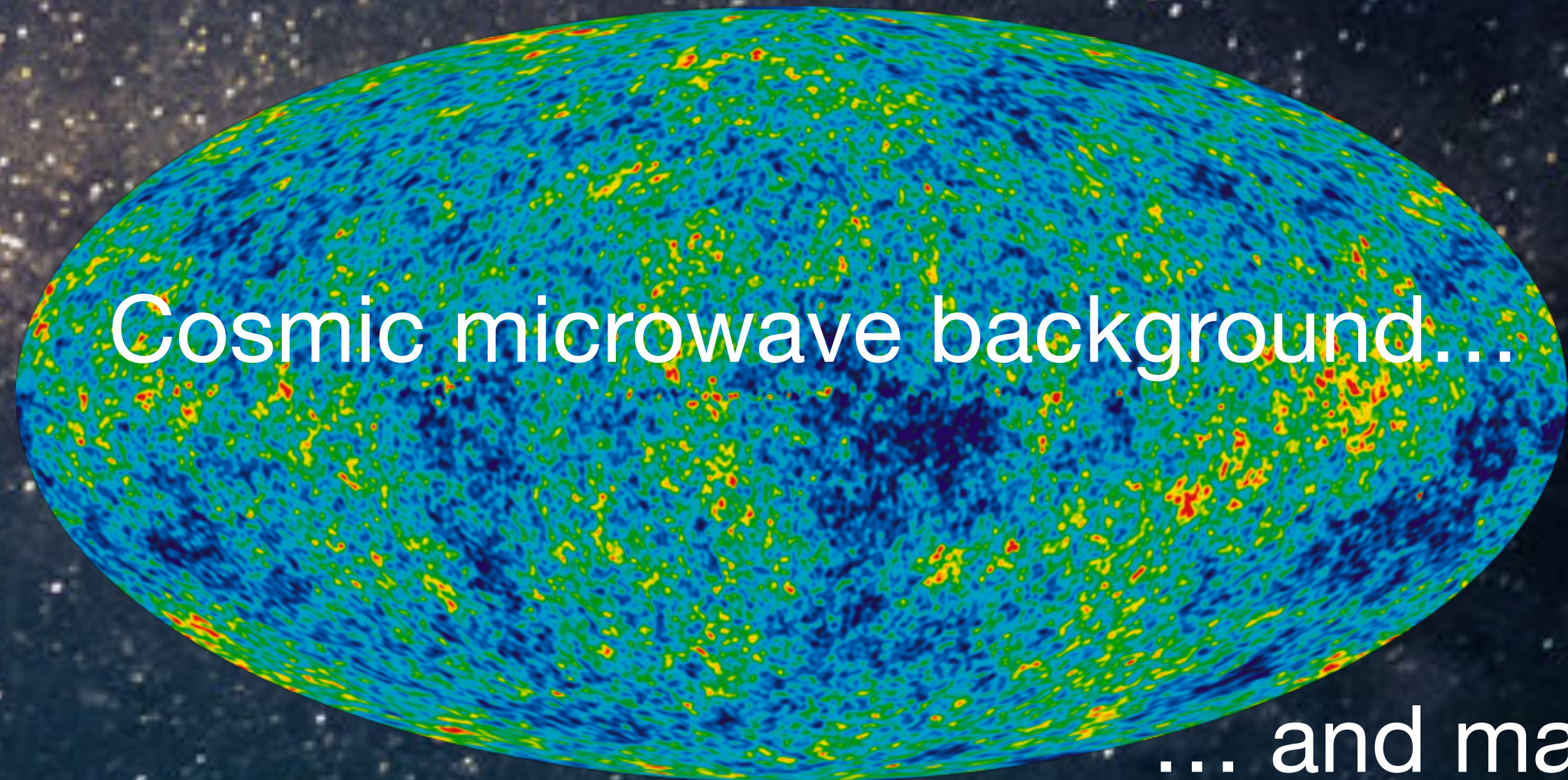
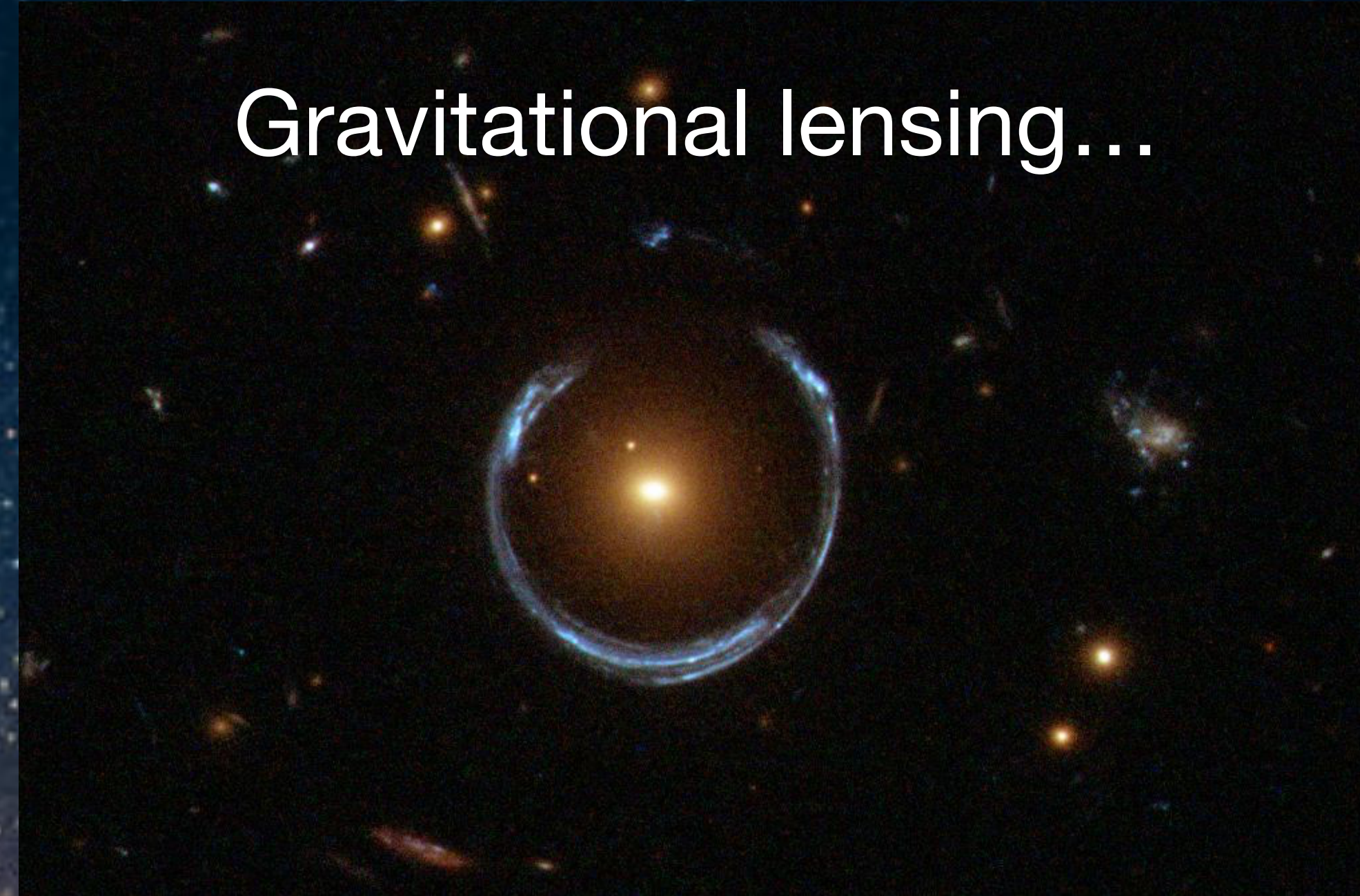

Dark matter detection

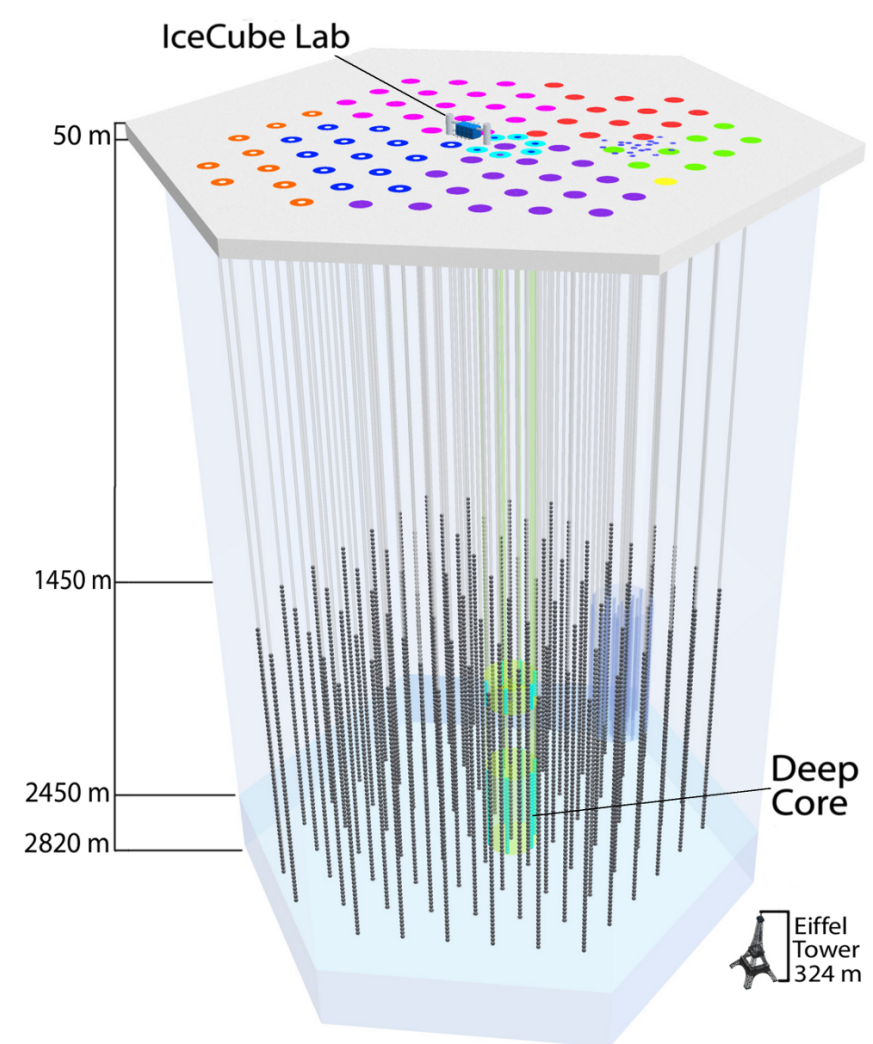
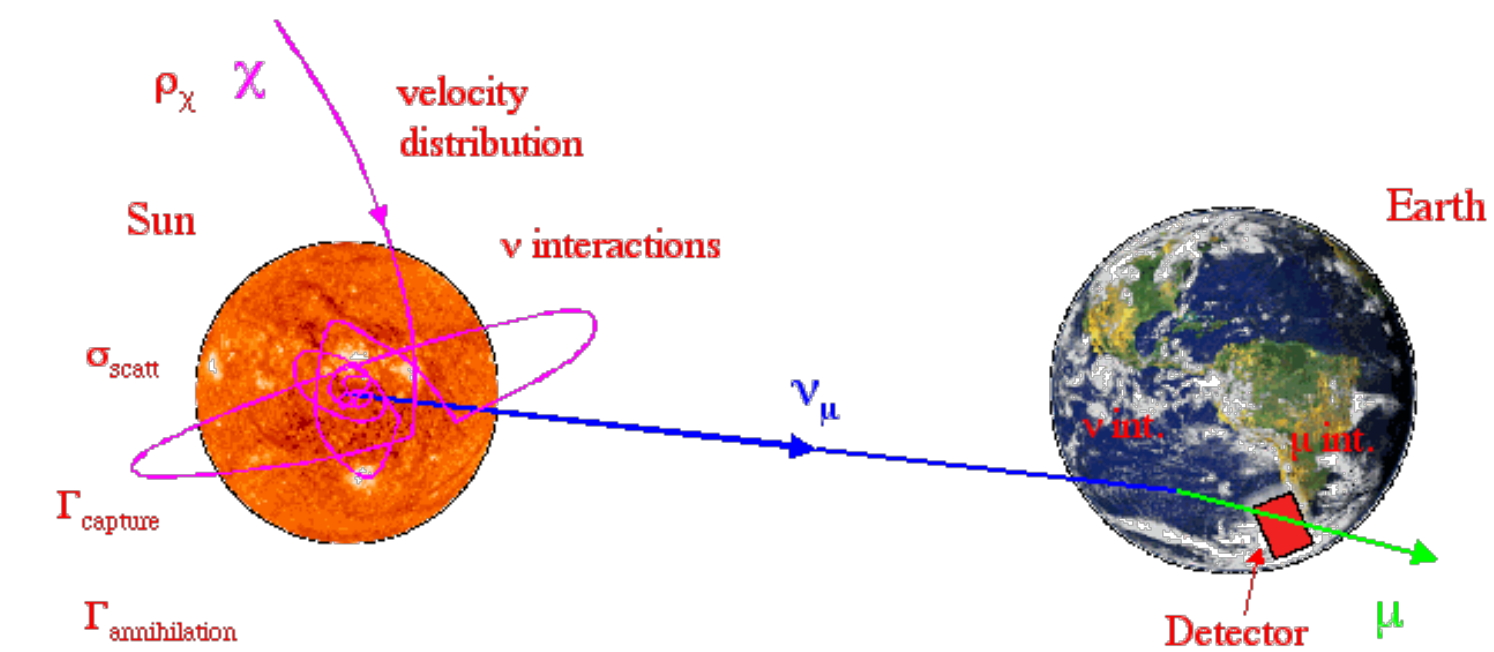

Annihilation or decay products from the Sun, Halo, etc.

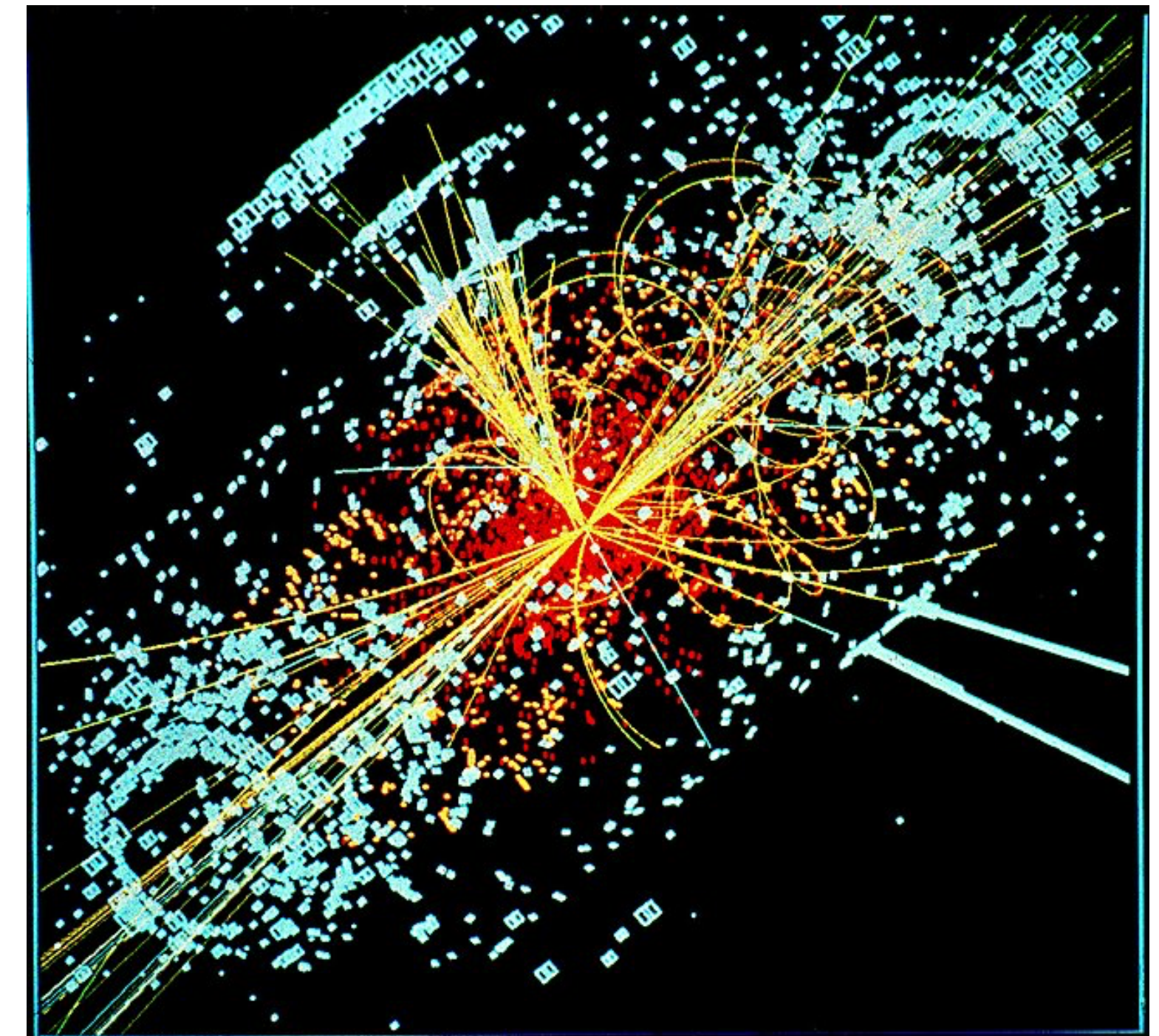
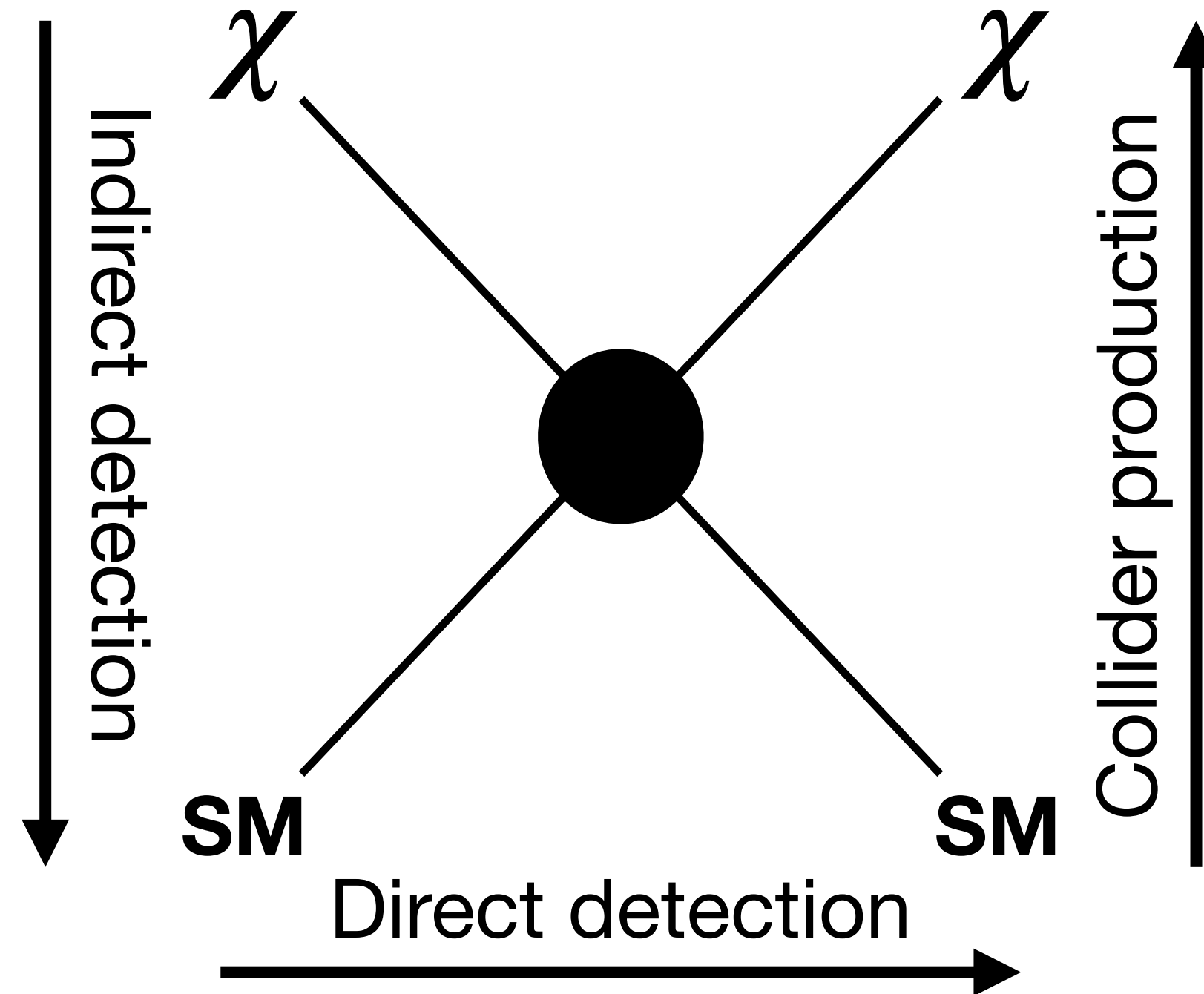

Search for missing energy

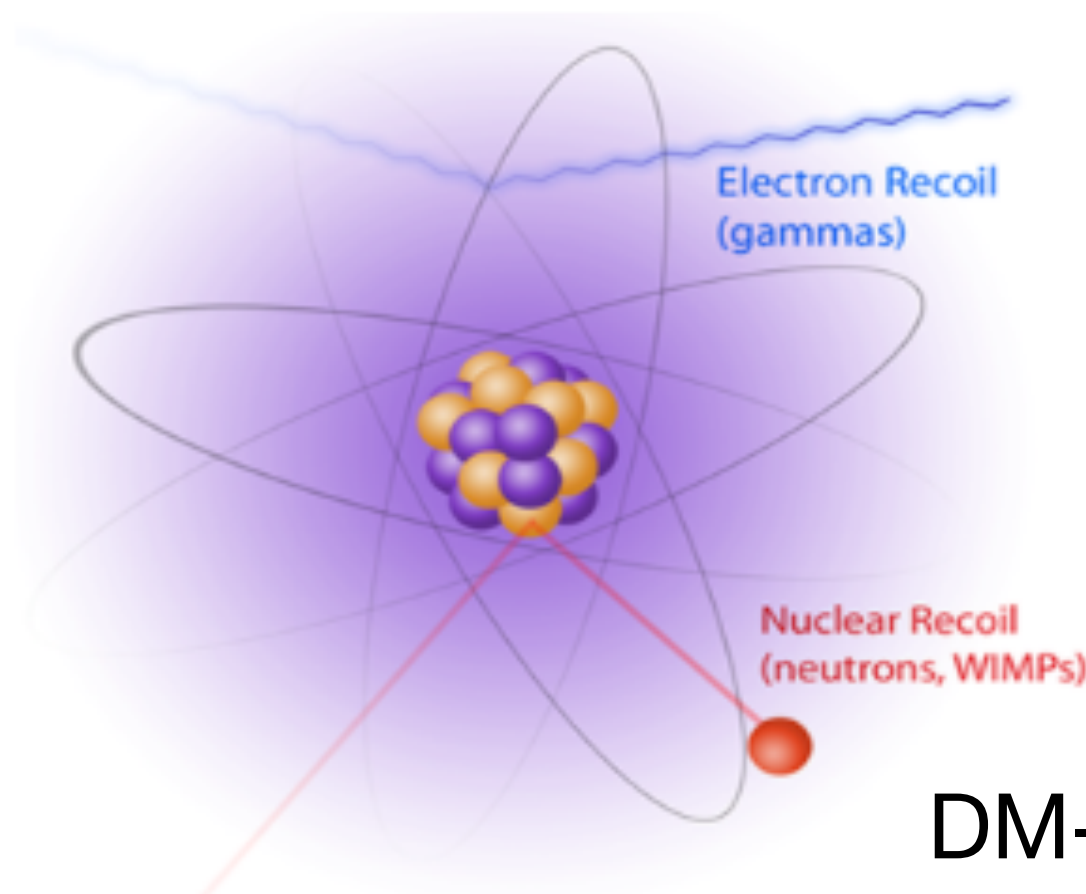

DM-Nucleon scattering

Current status of direct dark matter searches

- No sign of WIMPs down to $>10^{-46} \text{ cm}^2$ @ 30 GeV
- New experiments exploring low-mass dark matter
- DAMA's signal remains unresolved

Particle Data Group 2018

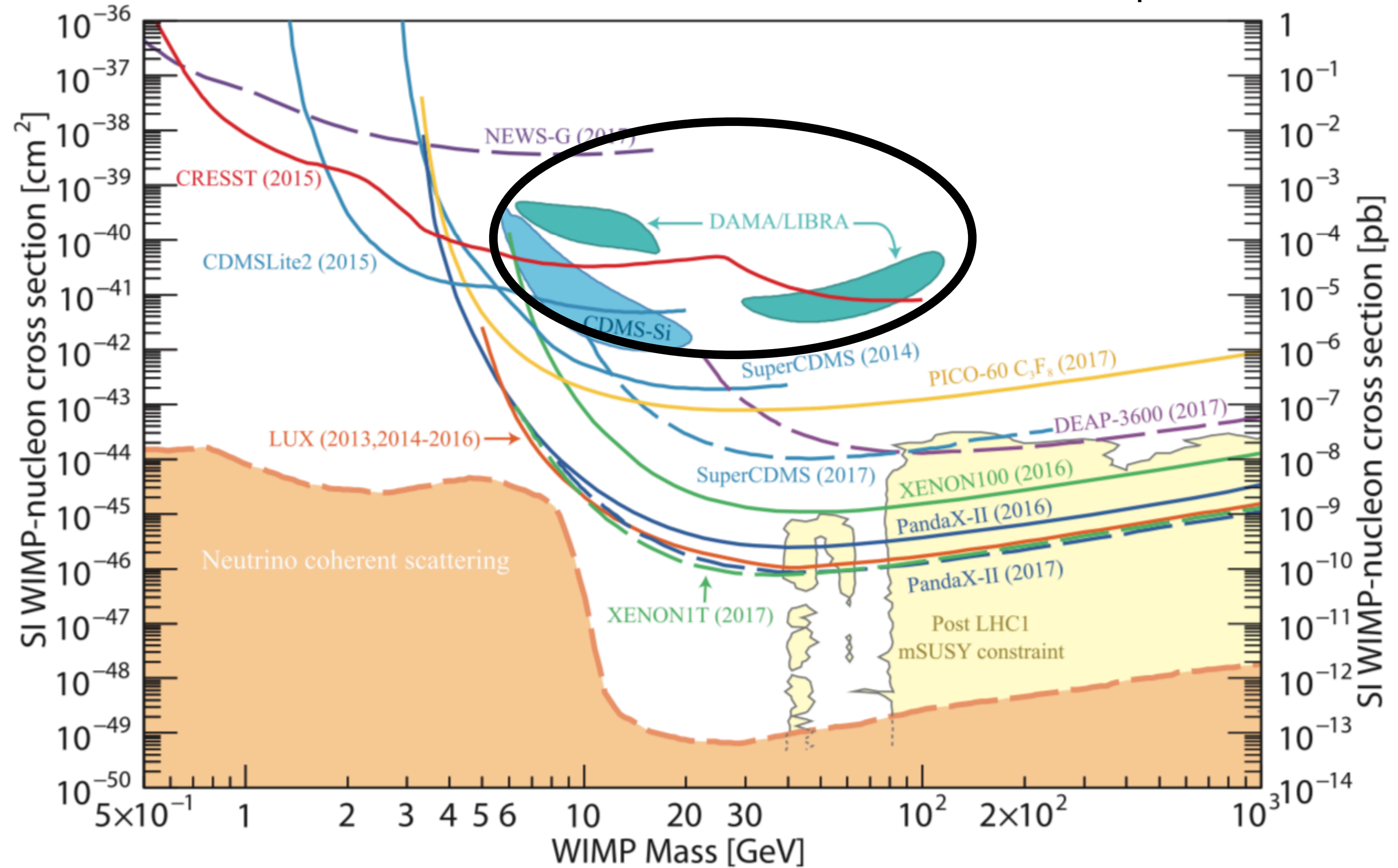

Need to directly test DAMA's result with NaI(Tl)

Annual Modulation of Dark Matter

image credit: quantamagazine.com

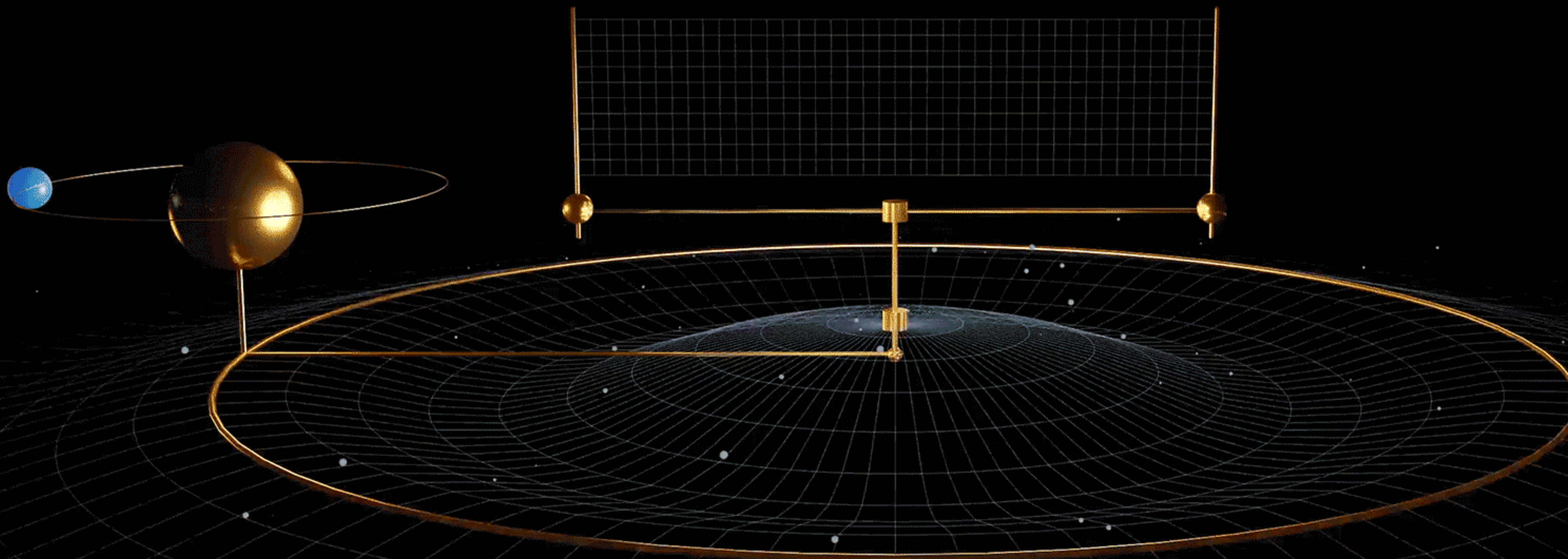

- Galactic dark matter is believed to be distributed in a halo
- Earth's motion around the sun causes annual modulation of dark matter (peak @ June 2)

DAMA experiment

- Located at LNGS, Italy
- 25 x 9.70 kg NaI(Tl) detectors
 - Crystals grown by Saint-Gobain
 - 0.85 - 1.3 cpd/kg/keV total background rate
- 2 PMTs/crystal
 - ~38.5% quantum efficiency
 - Light yield of 5.5 - 7.5 pe/keV
 - 10 cm quartz lightguides attached
- DAMA/NaI (100 kg 1996 - 2003),
DAMA/LIBRA phase 1 (250 kg, 2003-2010),
DAMA/LIBRA phase 2 (250 kg, 2010 - 2018)

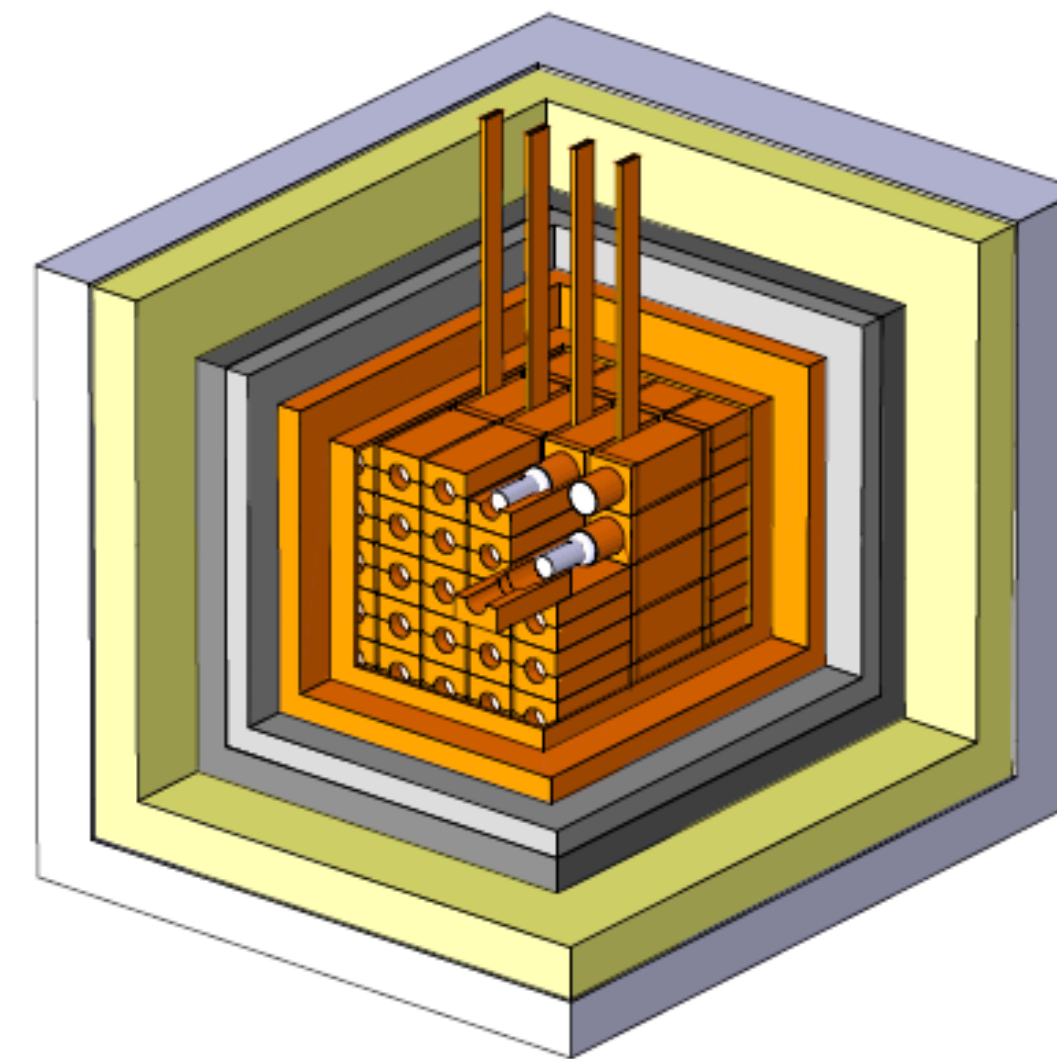
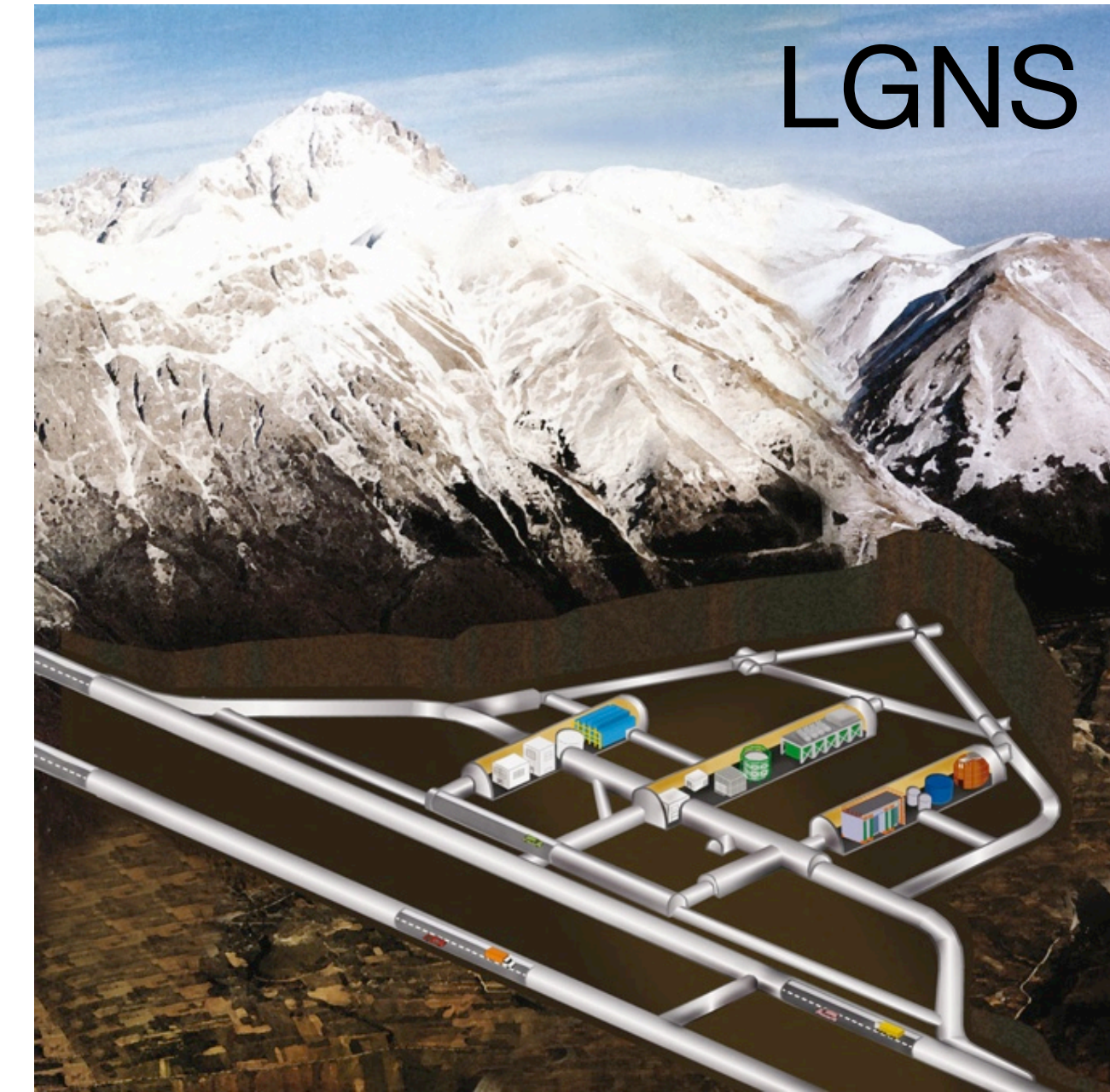

Bernabei *et al.*, NIM A (2008)

DAMA's annual modulation

Bernabei *et al.*, arXiv:1805.10486

- DAMA/LIBRA-phase2 result announced with 1 keV threshold
 - (1-6) keV: 9.5σ from 1.13 ton-year
 - (2-6) keV: 12.9σ from 2.46 ton-year
- Modulation amplitude: (0.0103 ± 0.0008) cpd/kg/keV in (2-6) keV
- Phase: (145 ± 5) days
- Period: (0.999 ± 0.001) year

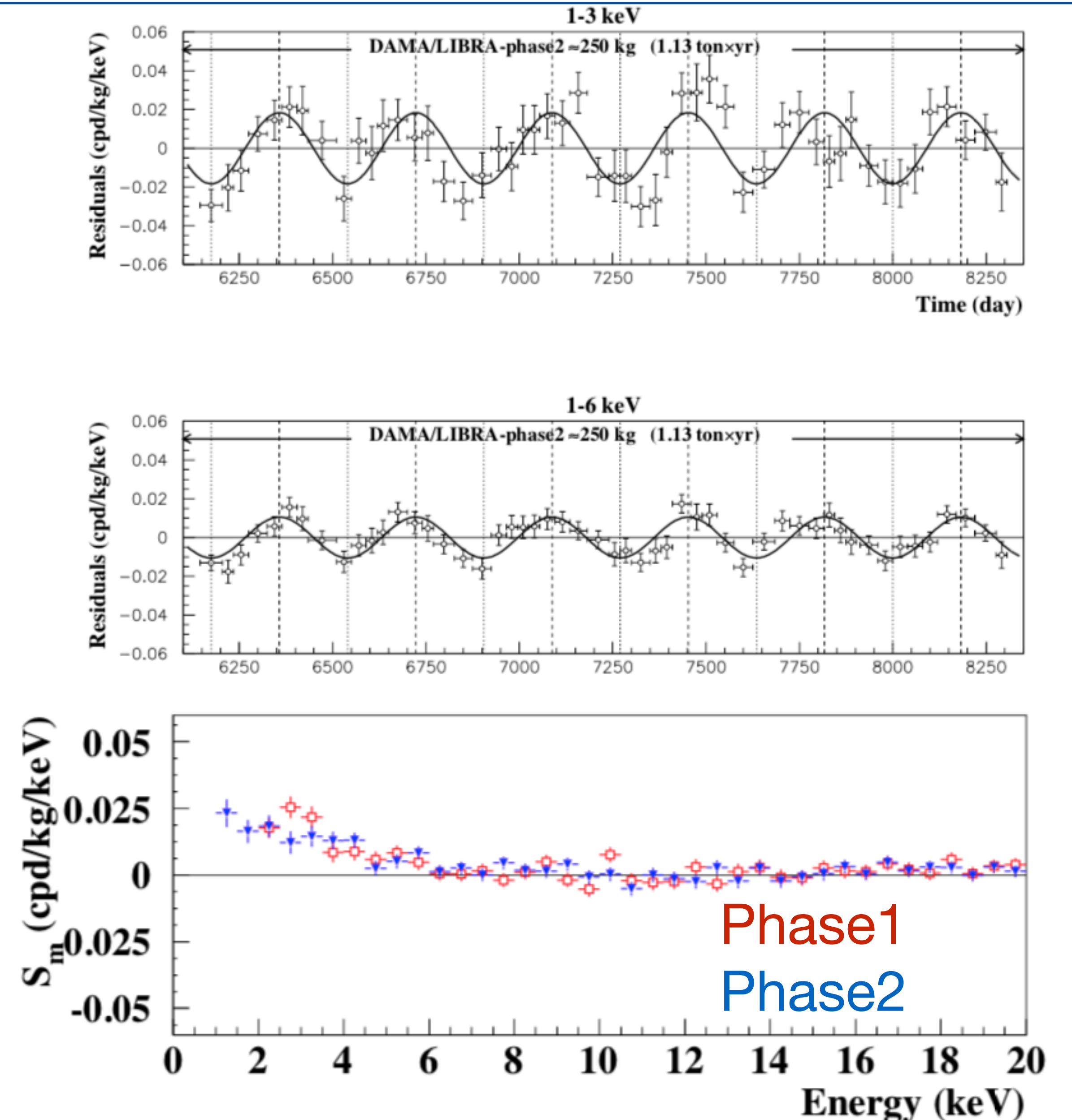

Interpretation of the DAMA result



*“What is causing DAMA’s modulation?
Could it be some backgrounds?”*

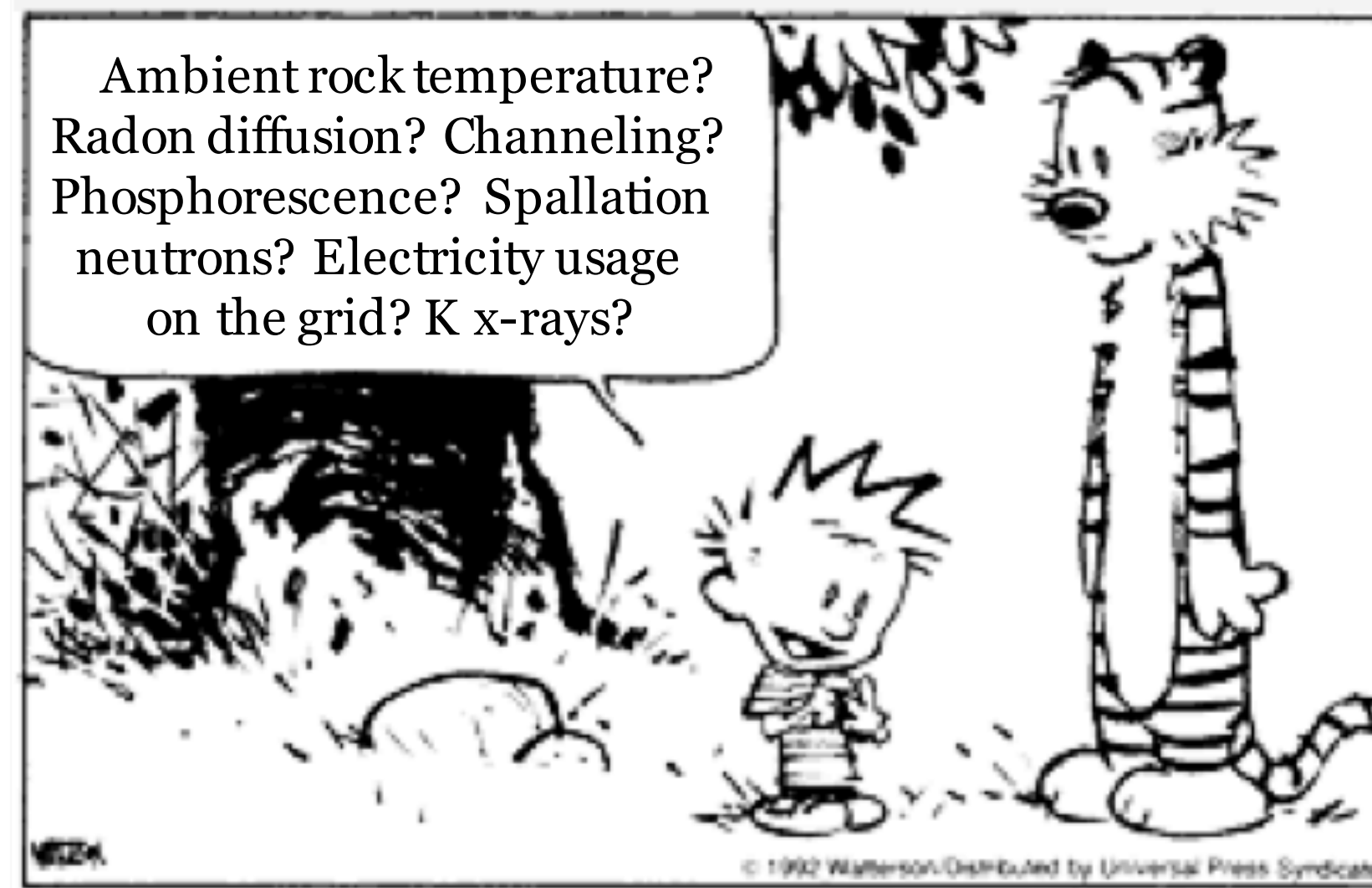

EPJC 56:333 (2008)
EPJC 72:2064 (2012)
EPJC 74:3196 (2014)





About interpretation and comparisons

See e.g.: Riv.N.Cim.26 ono.1(2003)1, IJMPD13(2004)2127, EPJC47(2006)263, IJMPA21(2006)1445, EPJC56(2008)333, PRD84(2011)055014, JMPA28(2013)1330022

...and experimental aspects...

- Exposures
- Energy threshold
- Detector response (phe/keV)
- Energy scale and energy resolution
- Calibrations
- Stability of all the operating conditions.
- Selections of detectors and of data.
- Subtraction/rejection procedures and stability in time of all the selected windows and related quantities
- Efficiencies
- Definition of fiducial volume and non-uniformity
- Quenching factors, channeling
- ...

...models...

- Which particle?
- Which interaction coupling?
- Which EFT operators contribute?
- Which Form Factors for each target-material?
- Which Spin Factor?
- Which nuclear model framework?
- Which scaling law?
- Which halo model, profile and related parameters?
- Streams?
- ...

Uncertainty in experimental parameters, as well as necessary assumptions on various related astrophysical, nuclear and particle-physics aspects, affect all the results at various extent, both in terms of exclusion plots and in terms of allowed regions/volumes. Thus comparisons with a fixed set of assumptions and parameters' values are intrinsically strongly uncertain.

No experiment can - at least in principle - be directly compared in a model independent way with DAMA so far

Is it an "universal" and "correct" way to approach the problem of DM and comparisons?

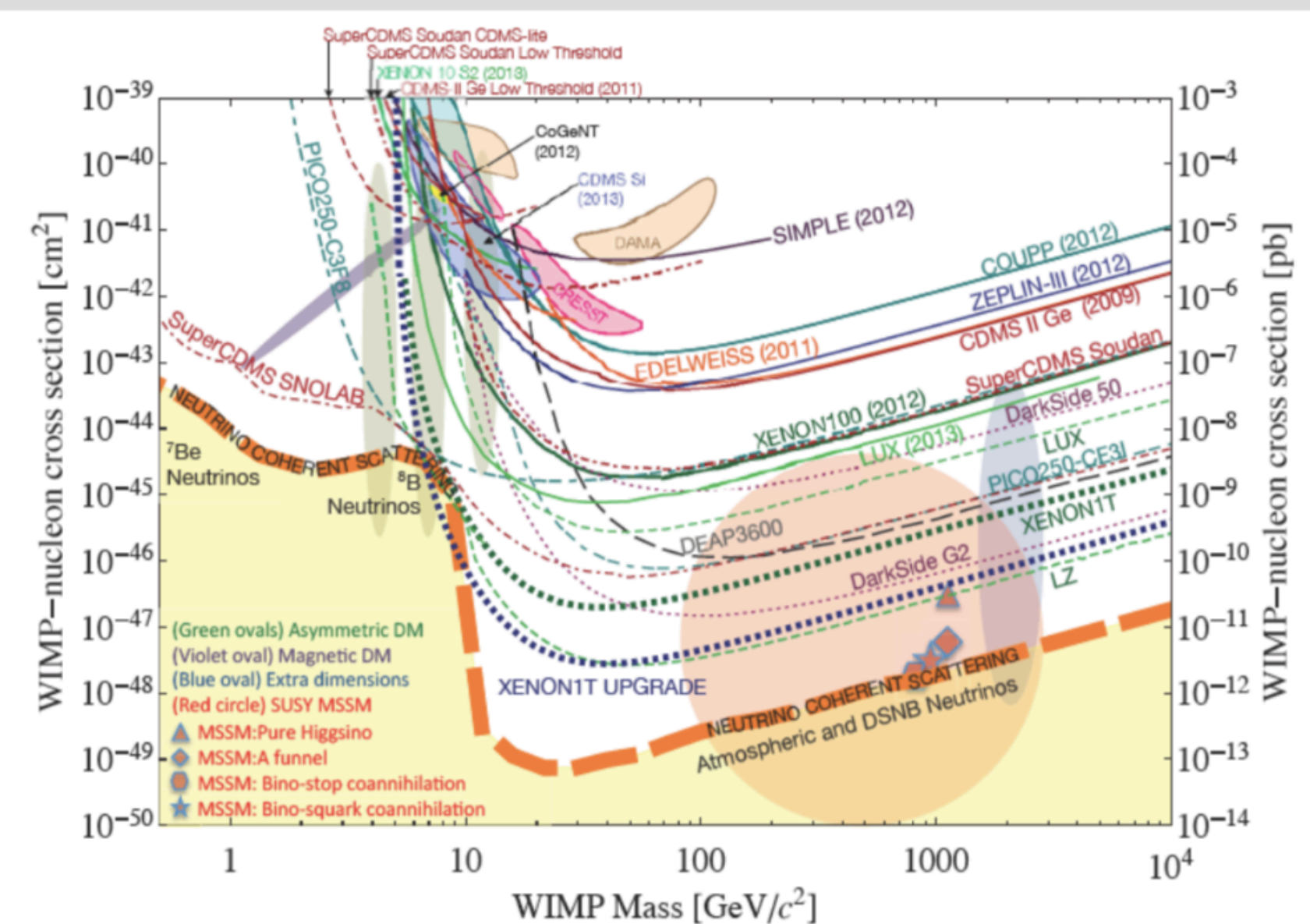

No, it isn't. This is just a largely arbitrary/partial/incorrect exercise

Need to directly test DAMA's result with the same target material

Global NaI(Tl) efforts



DAMA

SABRE@LGNS

★ Gran Sasso

COSINUS

★ Yangyang

KIMS

COSINE-100

PICO-LON

★ Kamioka

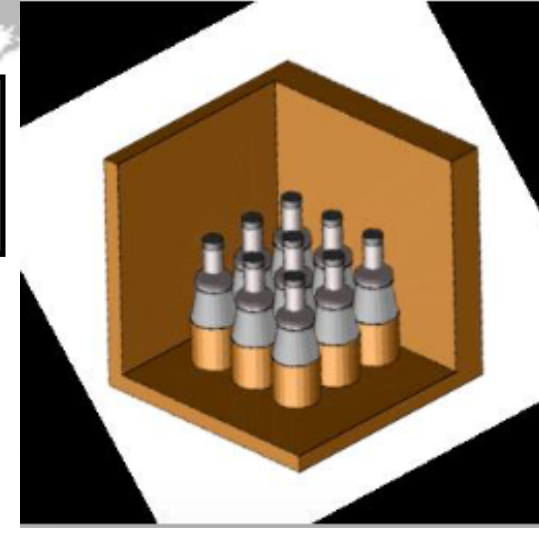

ANAIS

★ Boulby

★ Canfranc

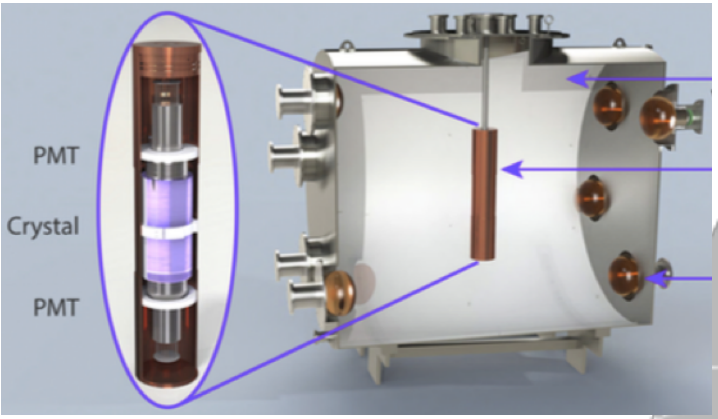

Nature **564**, 83-86 (2018)
 Eur.Phys.J. C **78** 107 (2018)
 Eur.Phys.J. C **77** 437 (2017)
 JINST **13** T02007 (2018)
 Phys.Rev. D **90** 052006 (2014) (Csl)

SABRE@Stawell

★ Stawell

Astropart. Phys. **35** (2012) 749
 Phys. Rev. D **90** 092005 (2014)
 Phys. Rev. D **93** 042001 (2016)
 Phys. Rev. D **95** 032006 (2017)

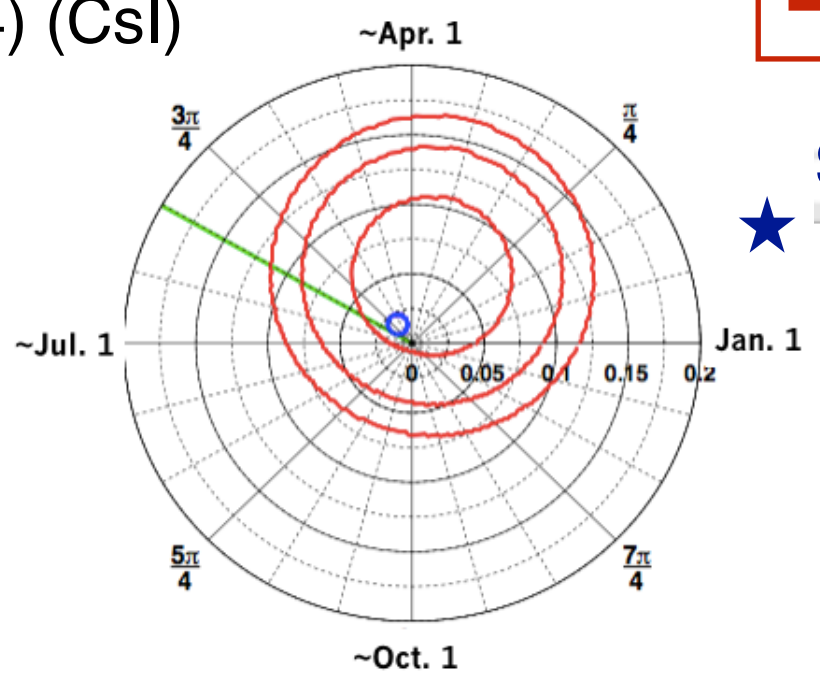

DM-Ice

★ South Pole

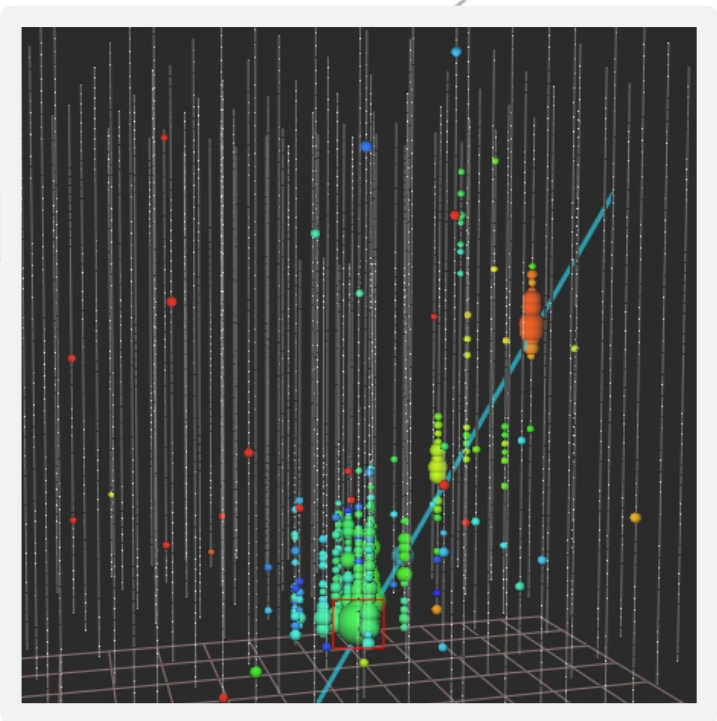
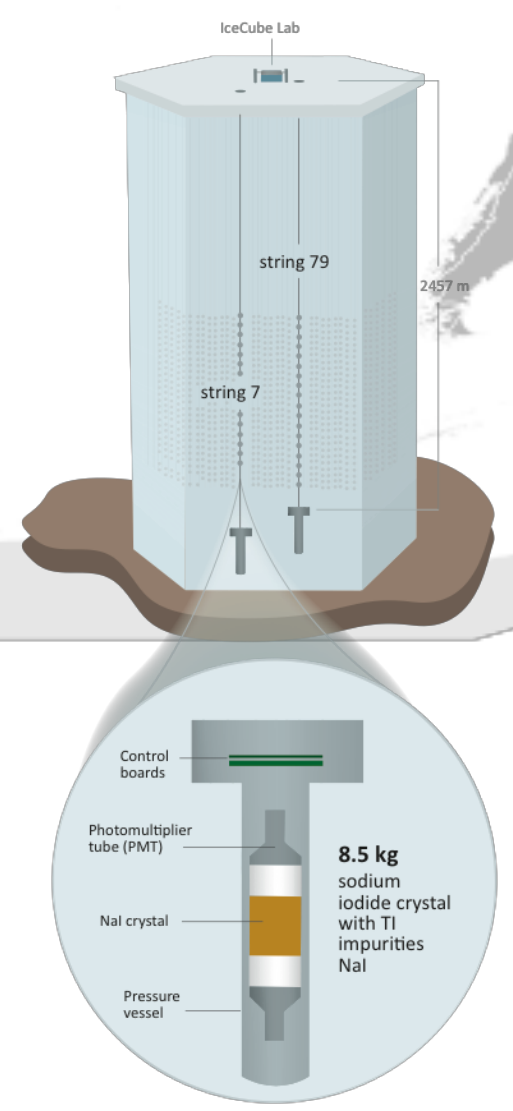

COSINE-100: Full-scale NaI(Tl) experiment at Y2L

COSINE-100 detector configuration

- 37 plastic scintillator panels to tag muons events
- 20cm thick lead shielding and 3cm thick copper box
- 2000L of liquid scintillator to tag internal/external background events
- 8 NaI(Tl) crystals

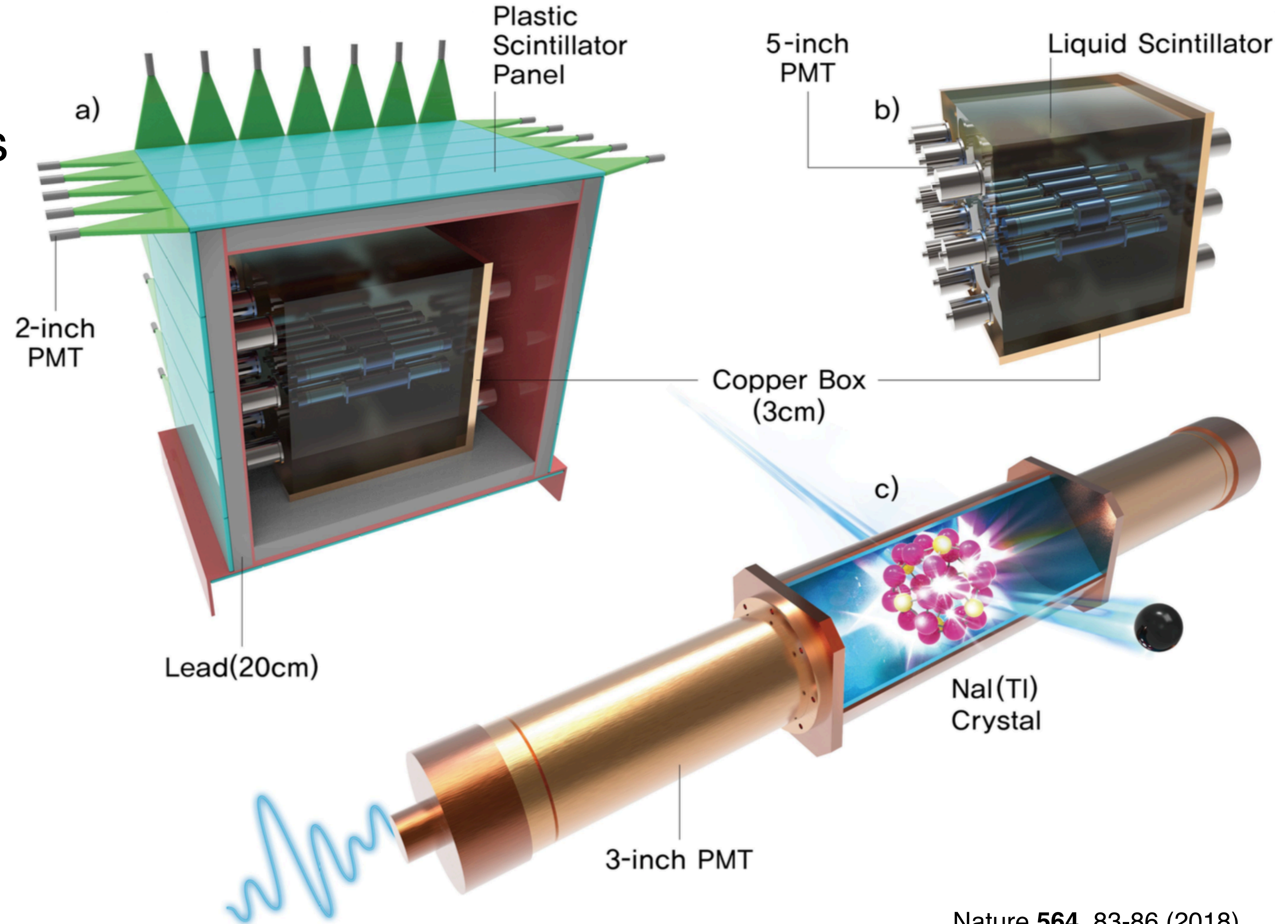

Nature **564**, 83-86 (2018)

COSINE-100 construction timeline

Dec. 2015



Jan. 2016

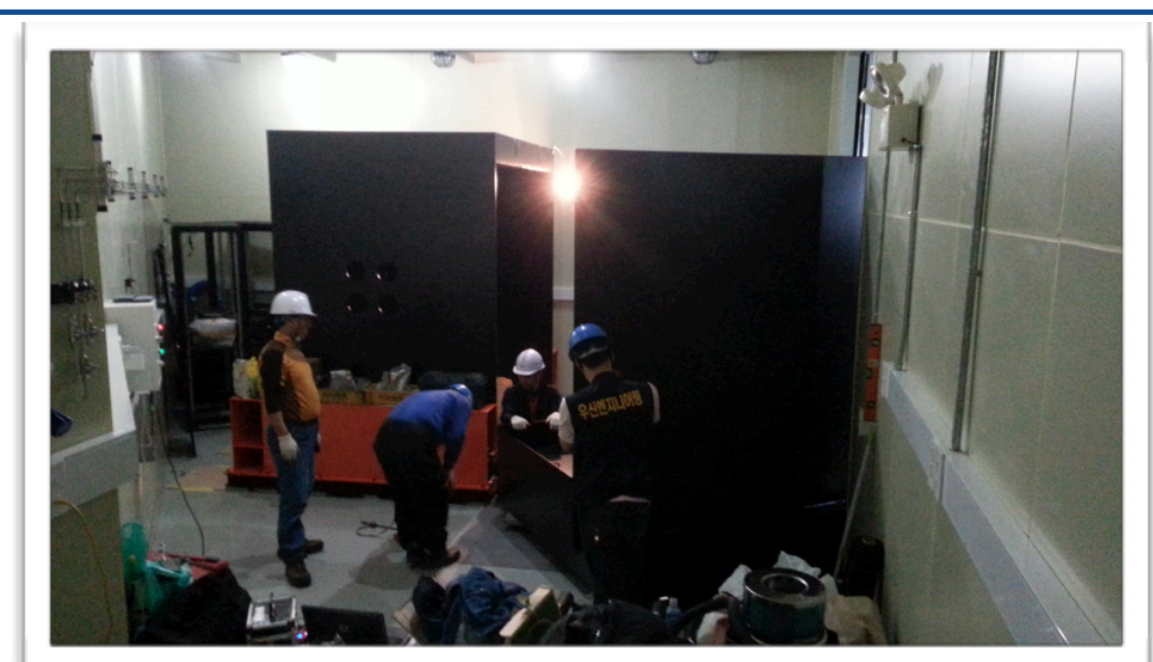

Feb. 2016



Mar. 2016

Apr. 2016

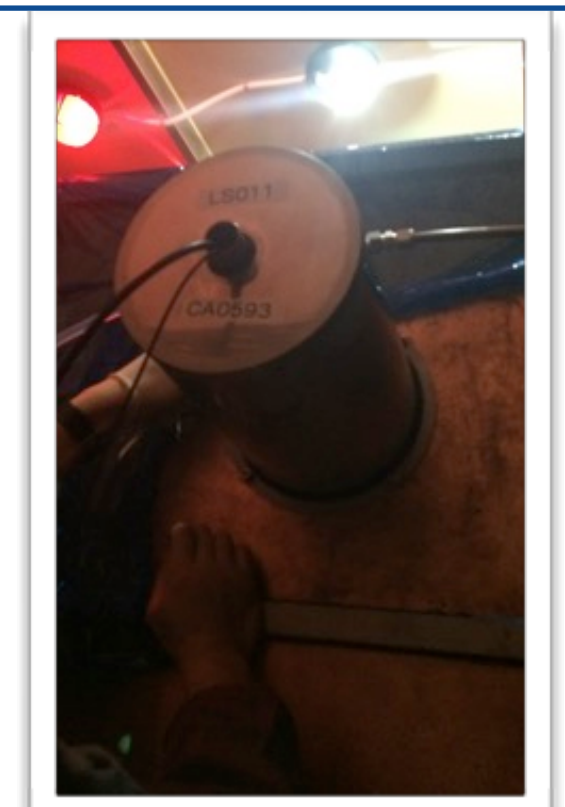
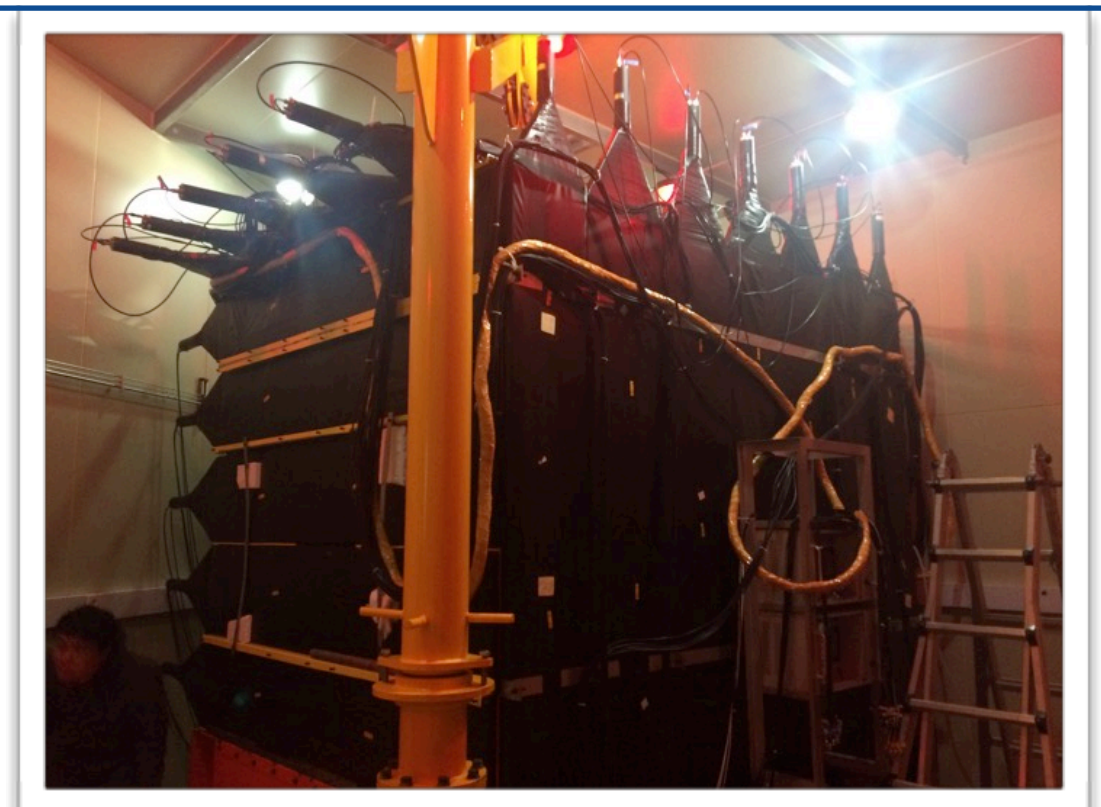
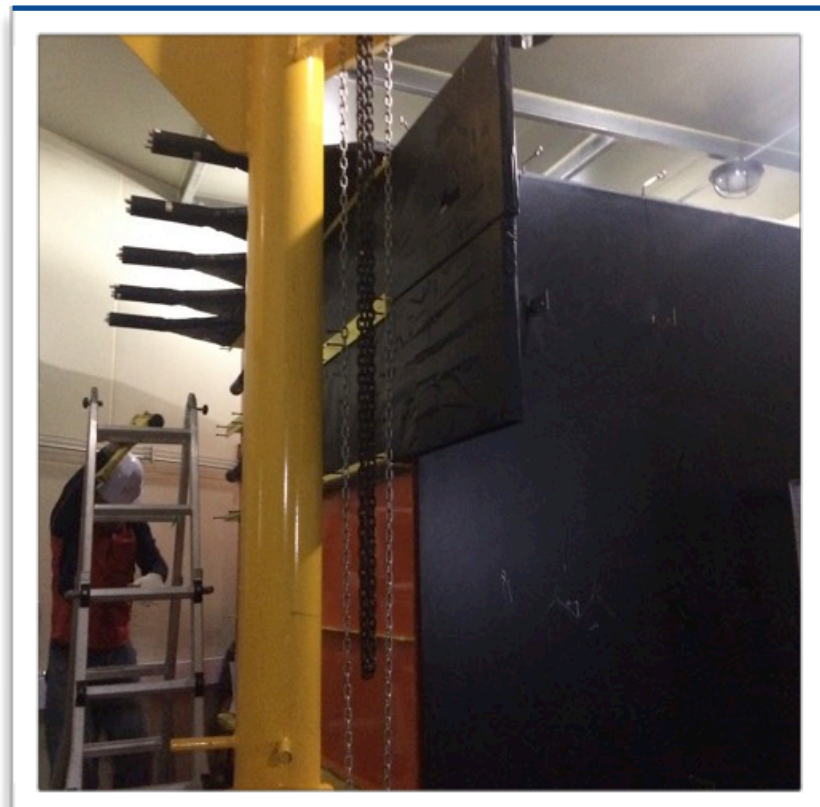

May. 2016

Jun. 2016

Sep. 2016

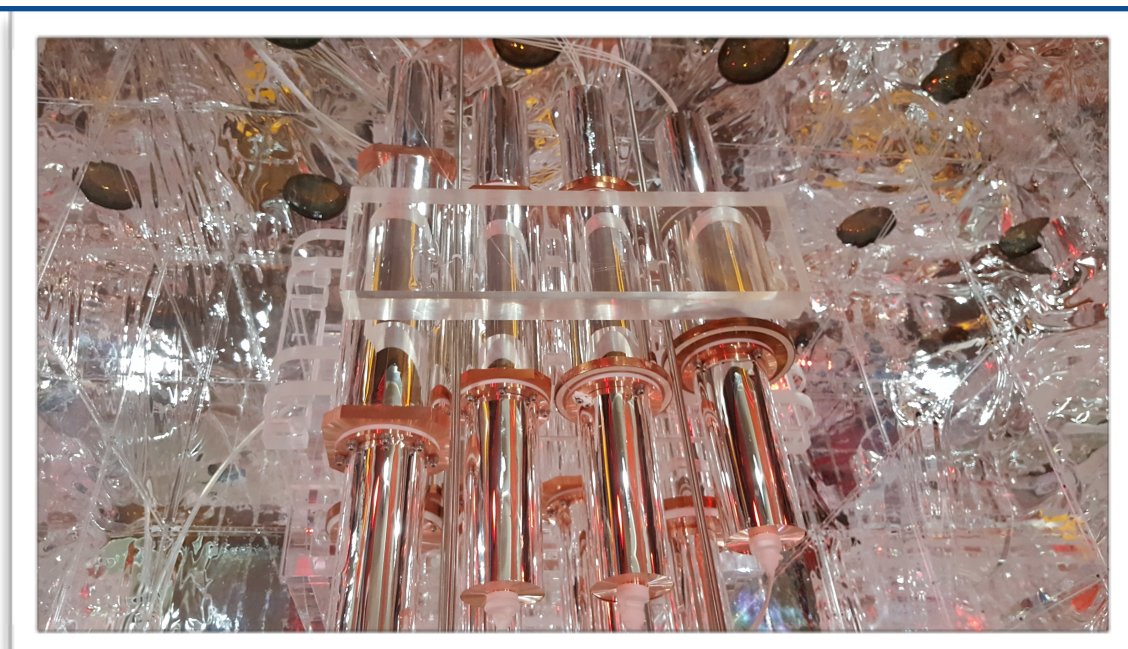

Crystal configuration

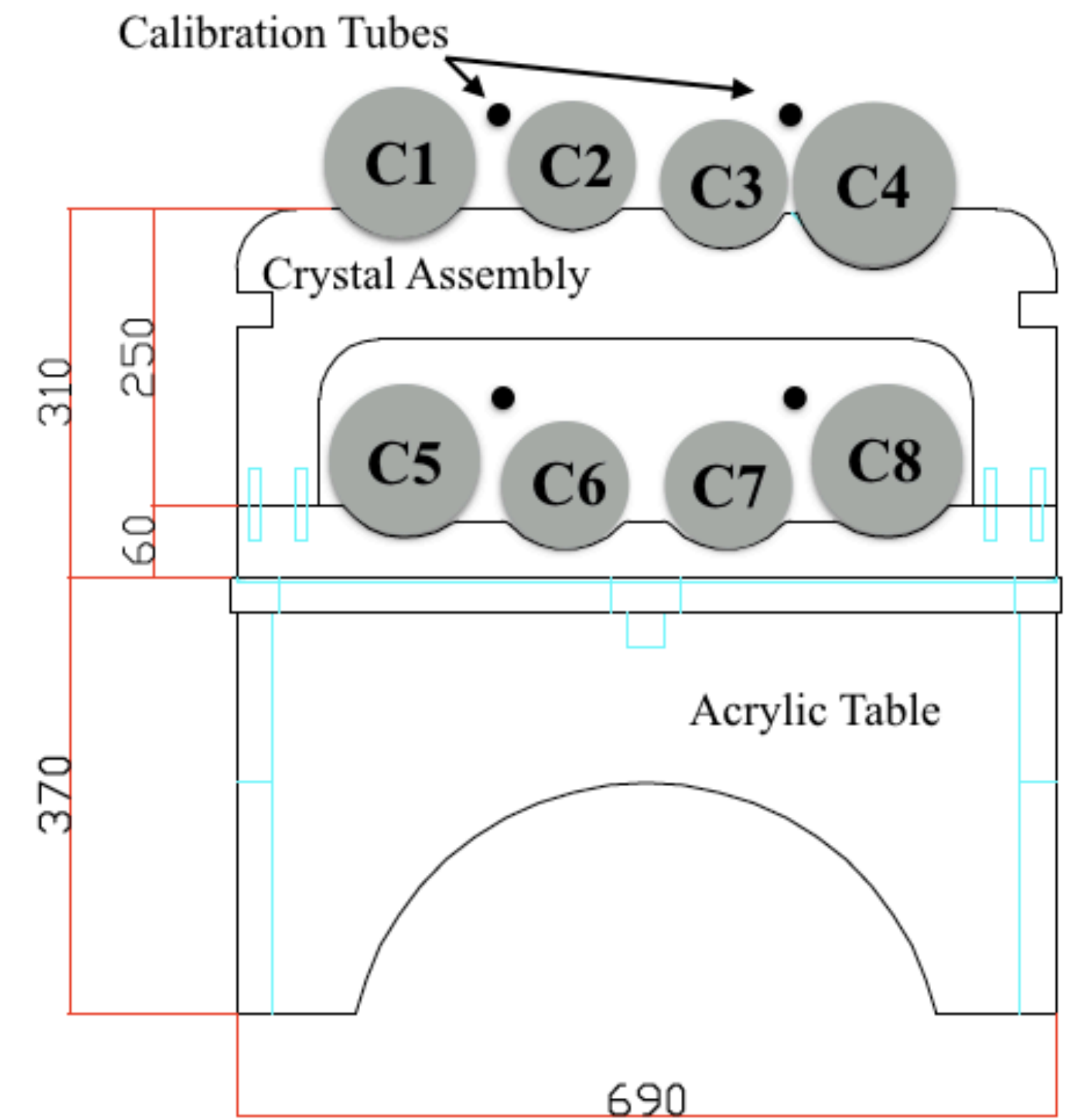
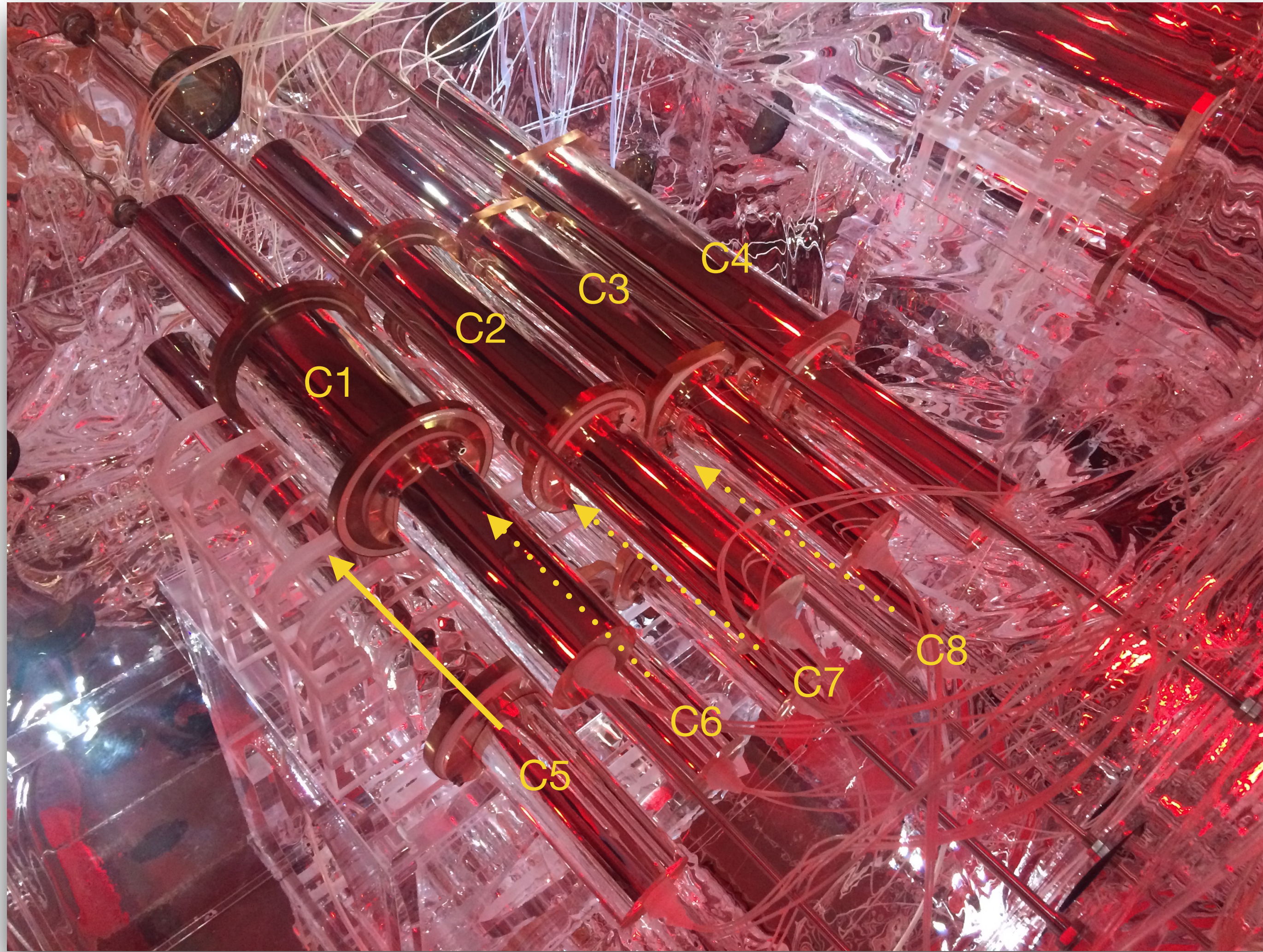

COSINE-100 operation

- Data taking since Sep. 2016
 - Stable operation
 - ~90% live time
 - Near 100% uptime outside of calibration
- > 23 months of data accumulation
 - SET1 data (59.5 days) - Background modeling, detector understanding, and WIMP analysis
 - SET2 data (621.0 days) - Annual modulation analysis

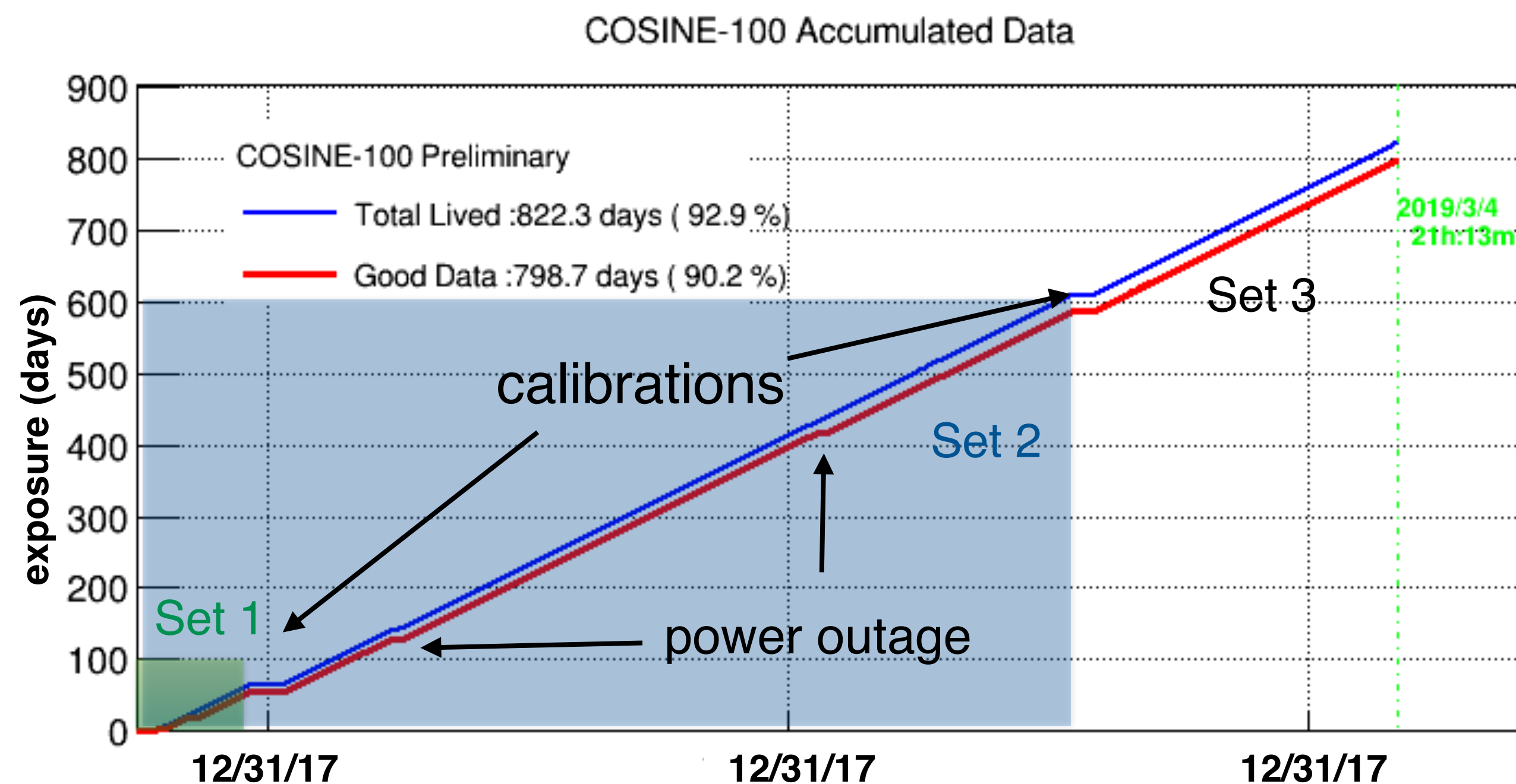

Environmental control/monitoring

- Monitoring stability of temperature, humidity, current/voltage, etc.

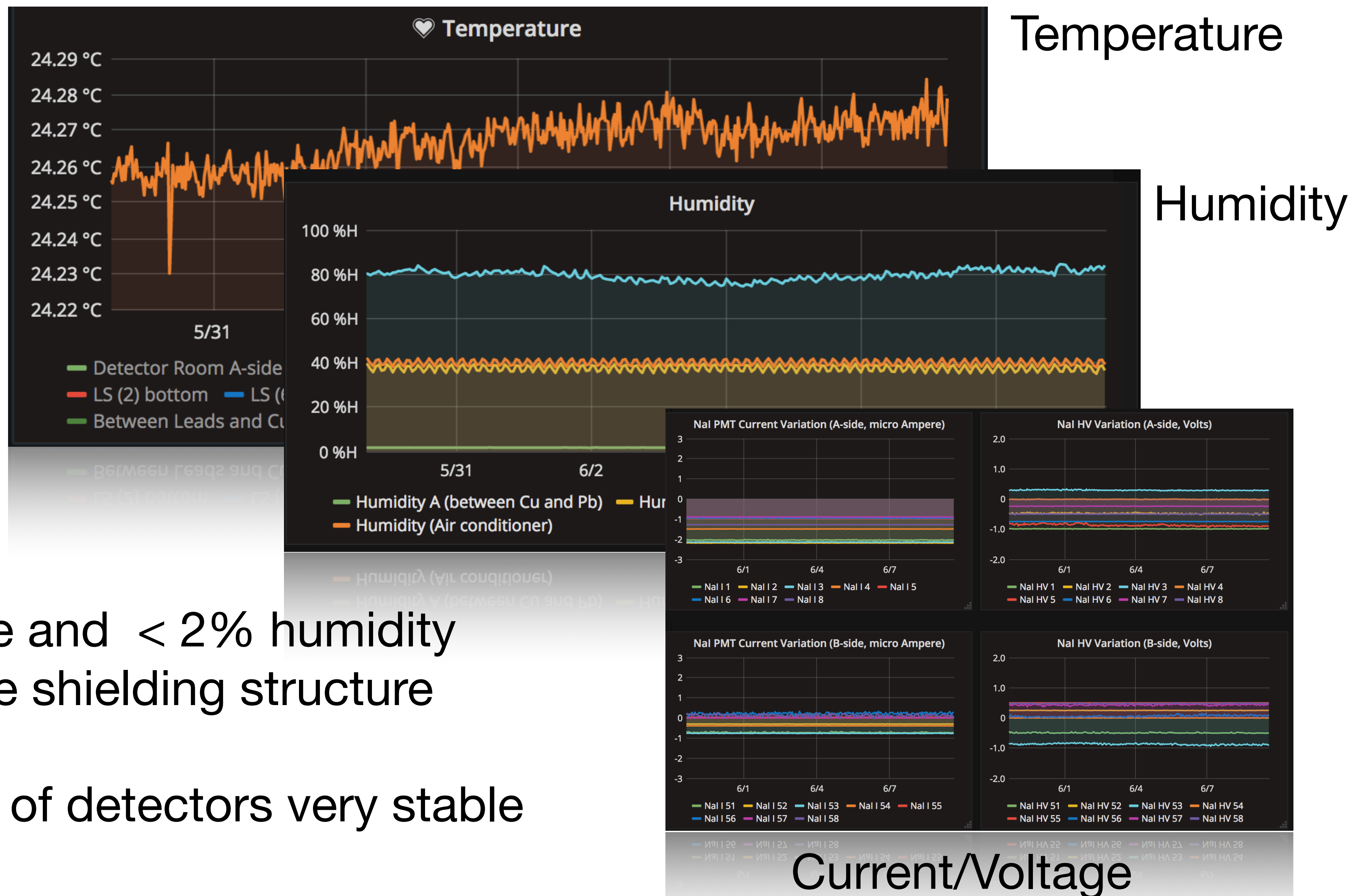

- $< 0.1 \text{ }^\circ\text{C}$ temperature and $< 2\%$ humidity fluctuation inside the shielding structure
- Current and voltage of detectors very stable

Environmental control/monitoring

- Monitoring stability of temperature, humidity, current/voltage, etc.

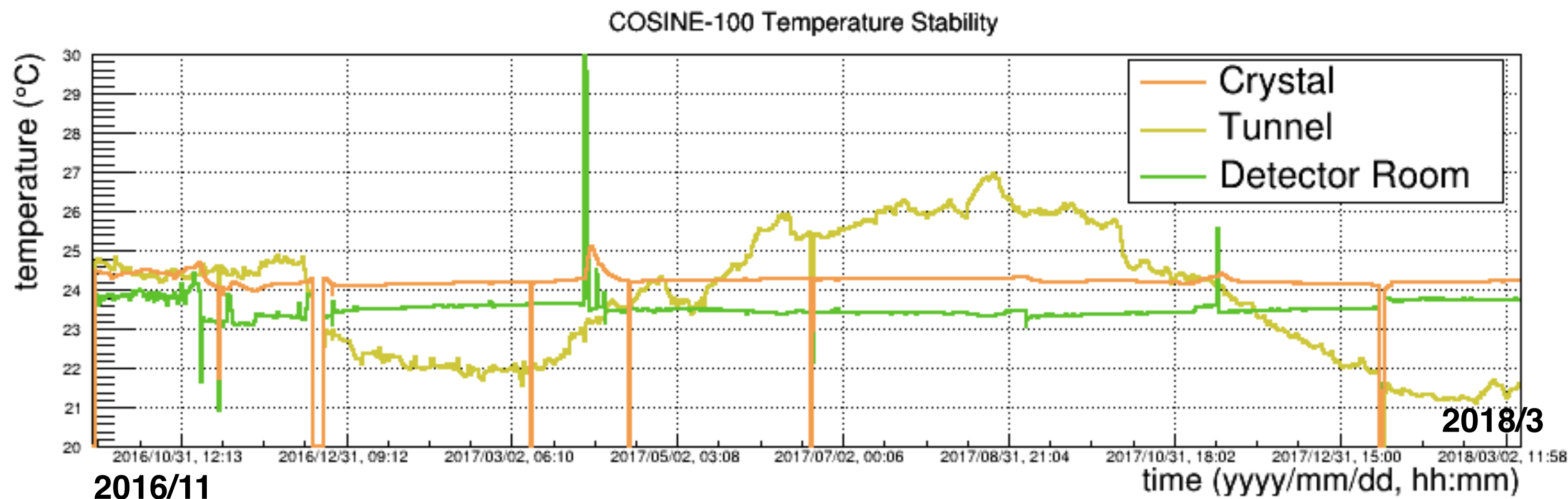

- < 0.1 °C temperature and < 2% humidity fluctuation inside the shielding structure

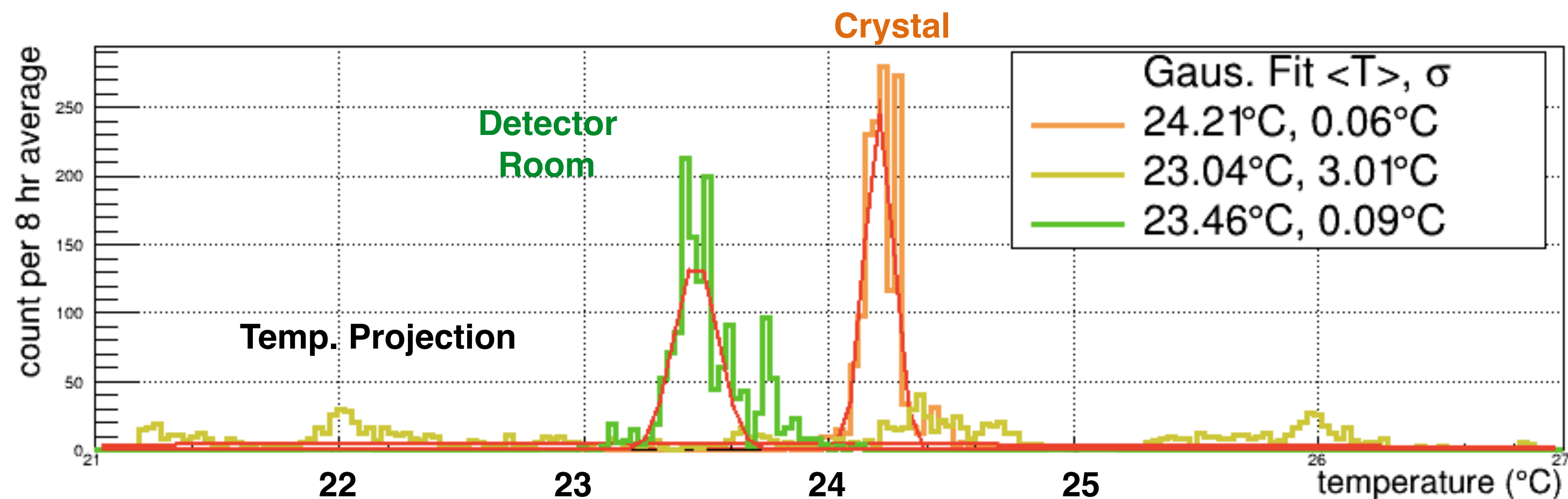

- Current and voltage of detectors very stable

Correcting for Gain Shifts

- Position of internal ^{210}Pb decays also monitored over time
- Gain shift corrected for by dividing out linear behavior

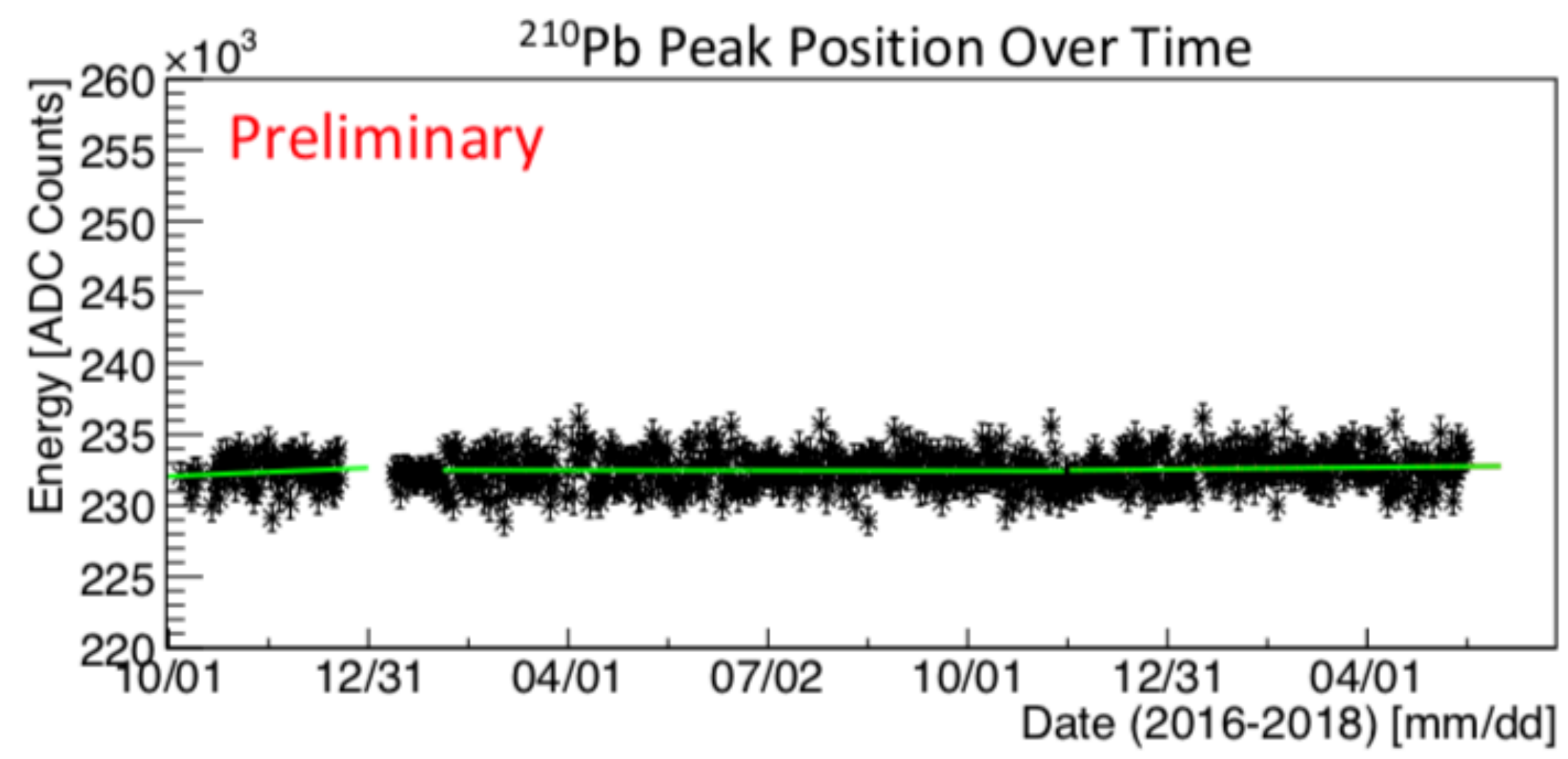
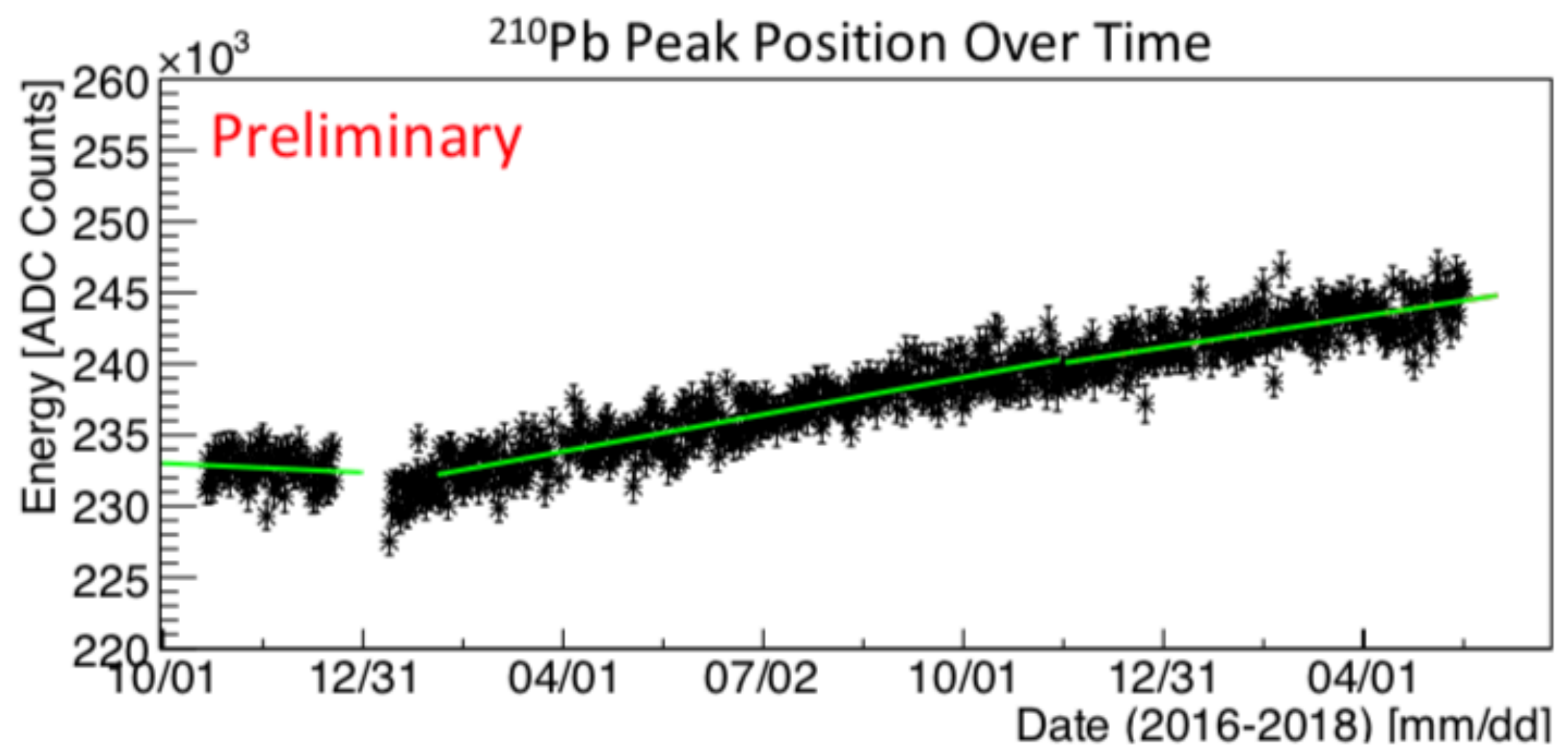
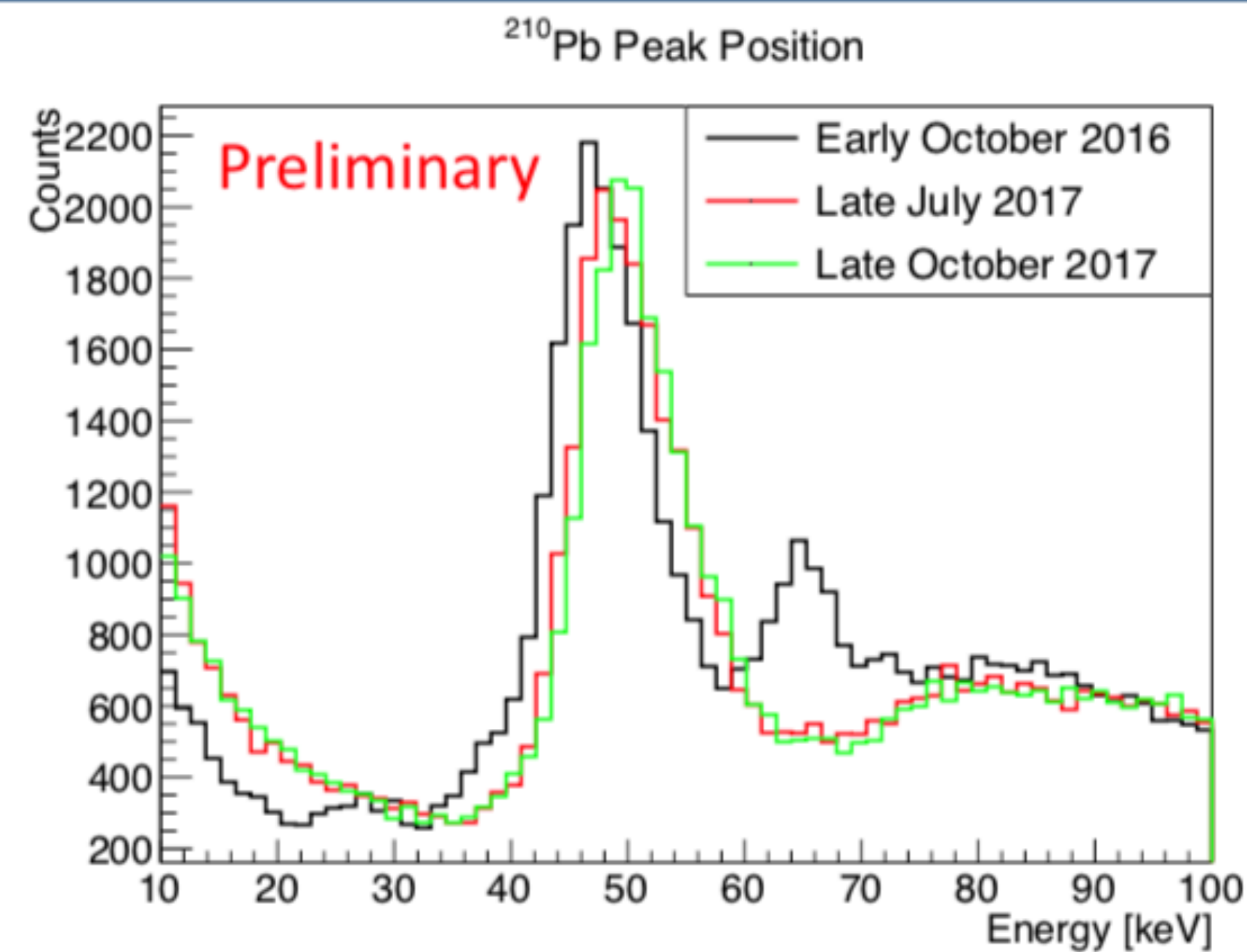

Liquid scintillator veto

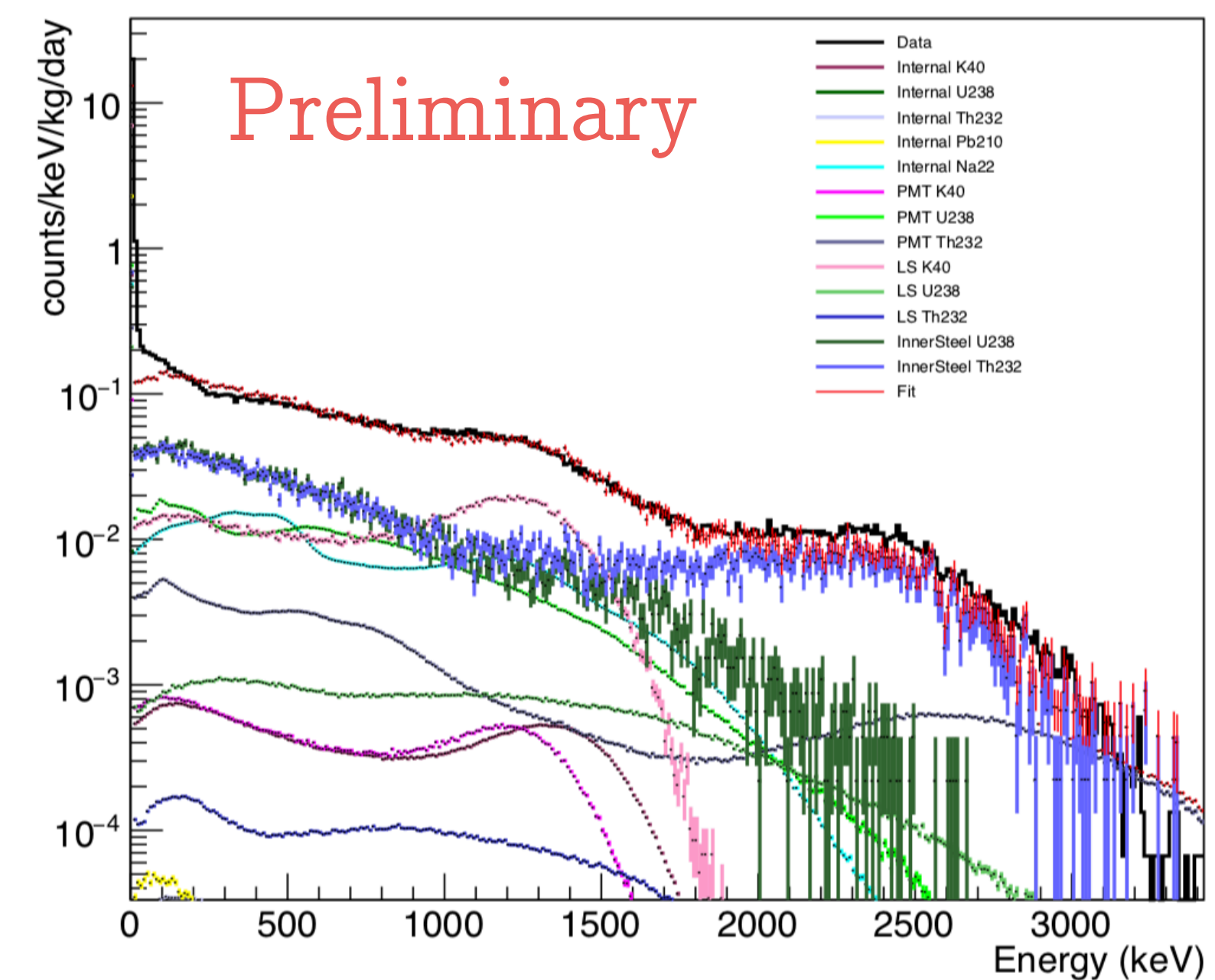
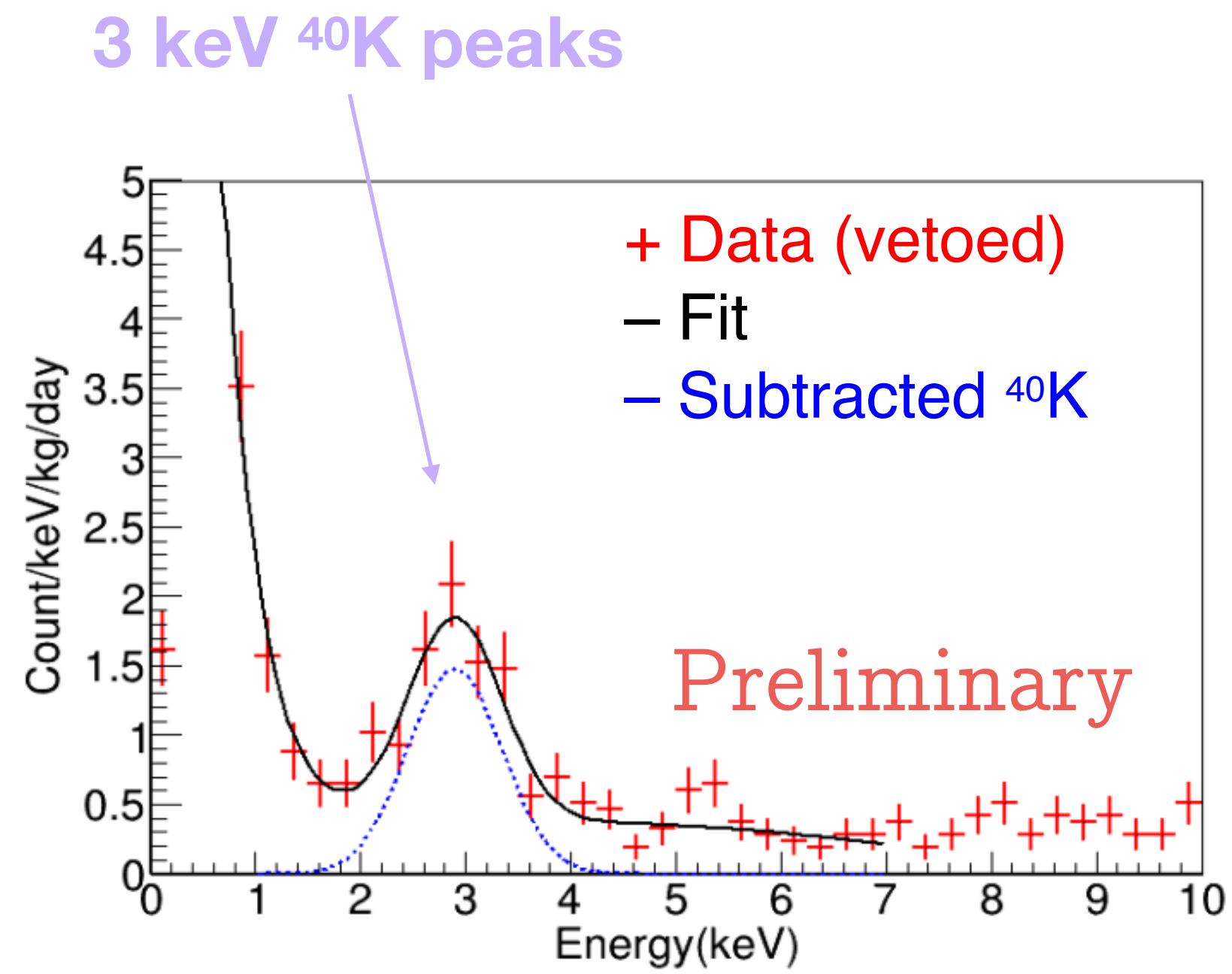
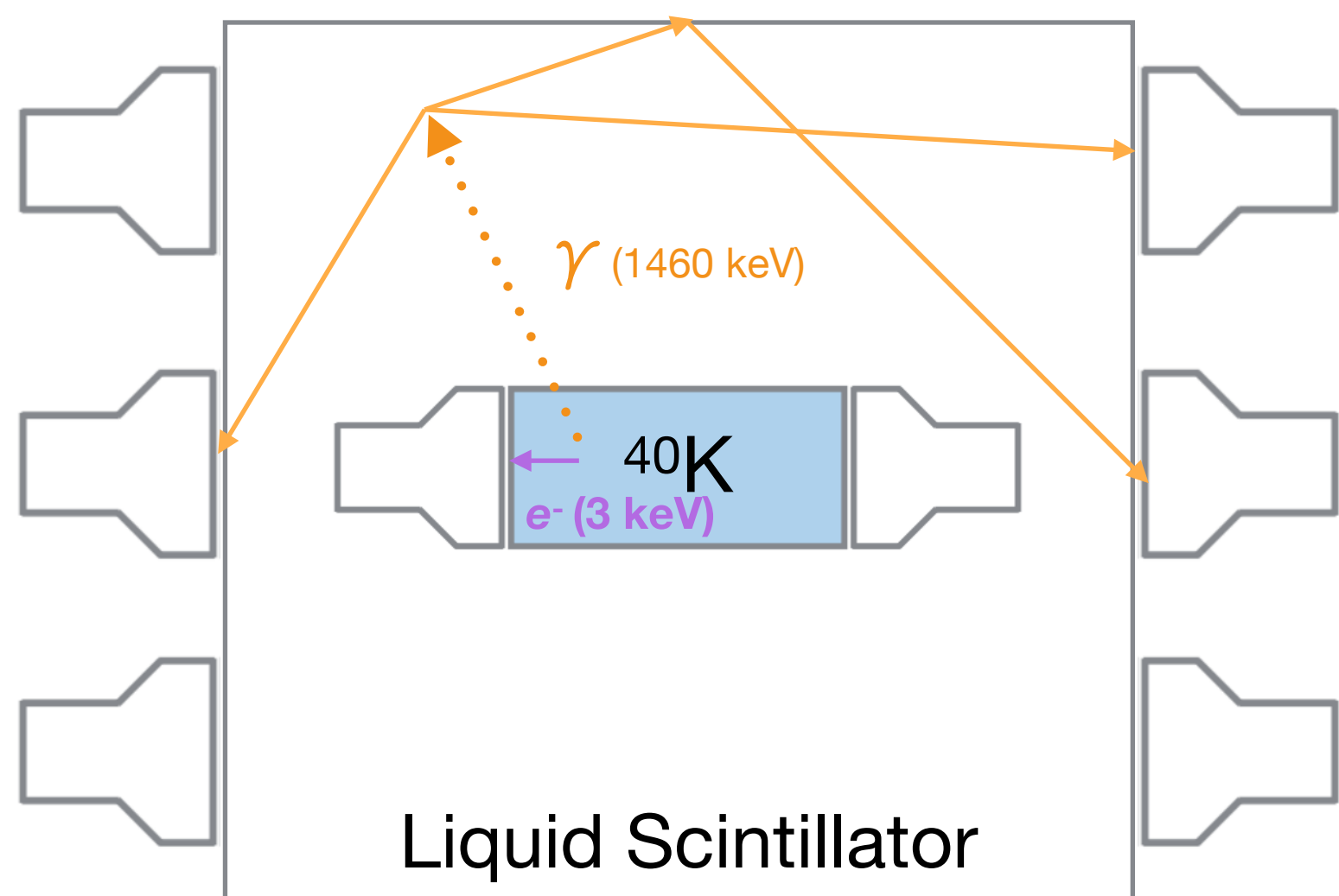

- ^{40}K emits 1460 keV gamma with 3 keV Auger electron energy deposition in NaI crystal
- Tagging 1460 keV events with LS enables **vetoing of 3 keV background events**
- Liquid scintillator internal contamination well modeled with simulation

Muon detector

- Muon veto with 37 plastic scintillator panels with 2-inch PMTs
- Events correlated with muon tagged
- Muon-induced events in NaI(Tl) under investigation

H. Prihitiadi *et al.* JINST **13** T02007 (2018)

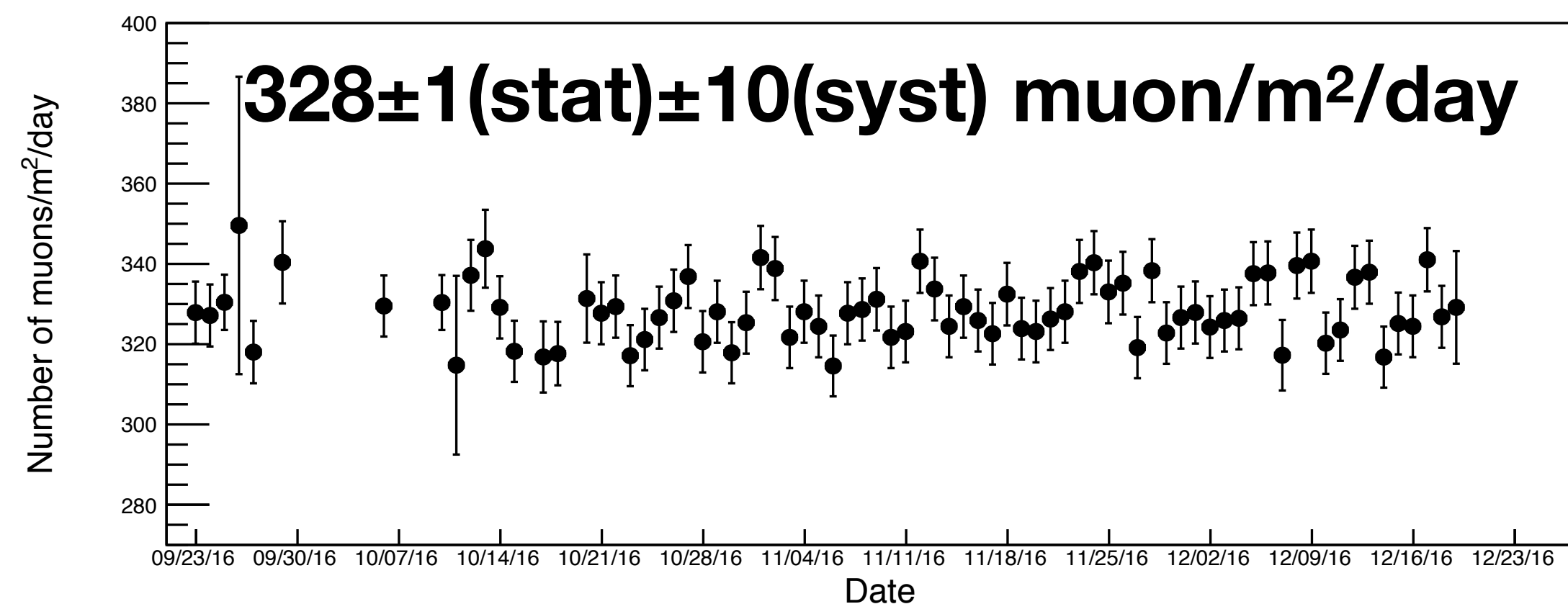
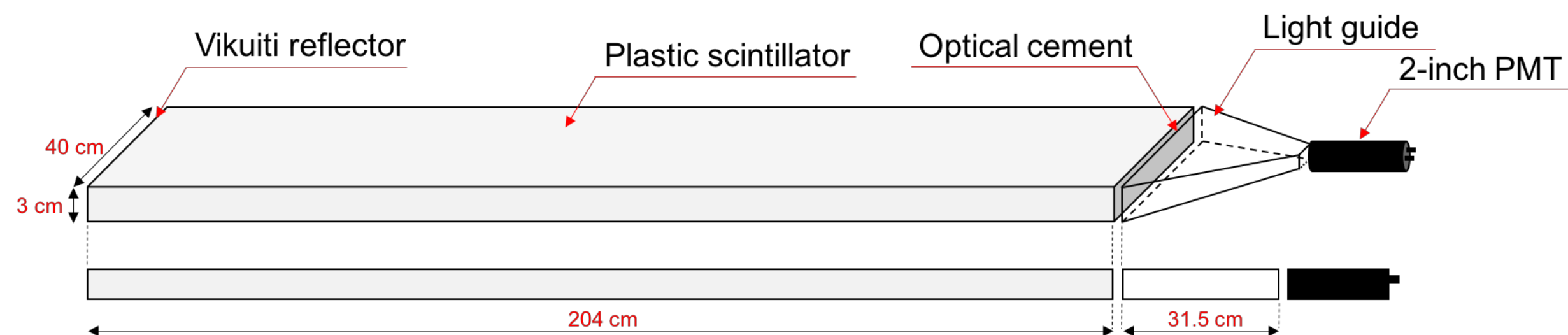
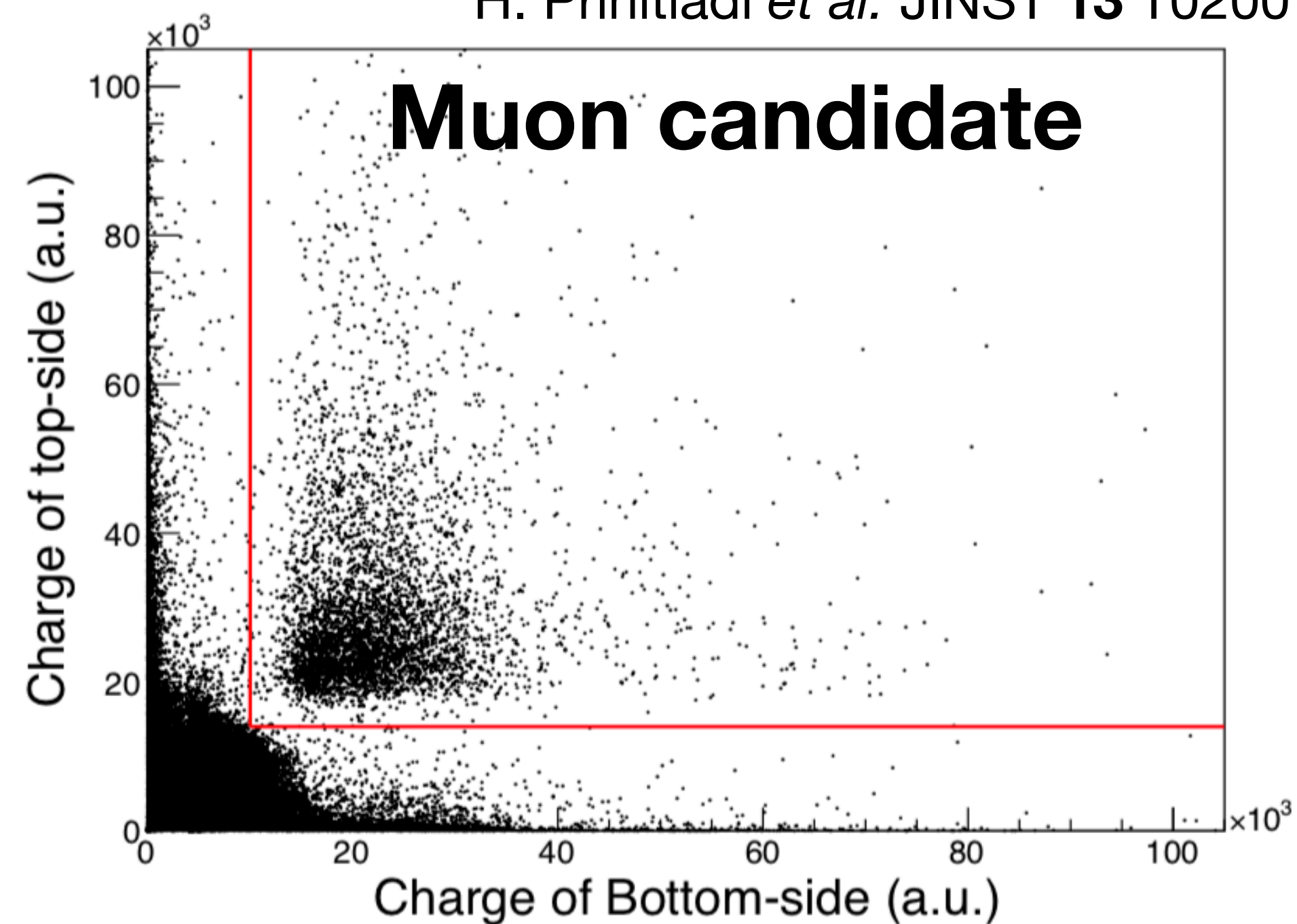

- 8 Crystals, total 106 kg
- Culmination of R&D program with Alpha Spectra
- U/Th/K below DAMA, ^{210}Po very close
- High light yield
- Crystal-5 & 8 used primarily for veto due to low light yield

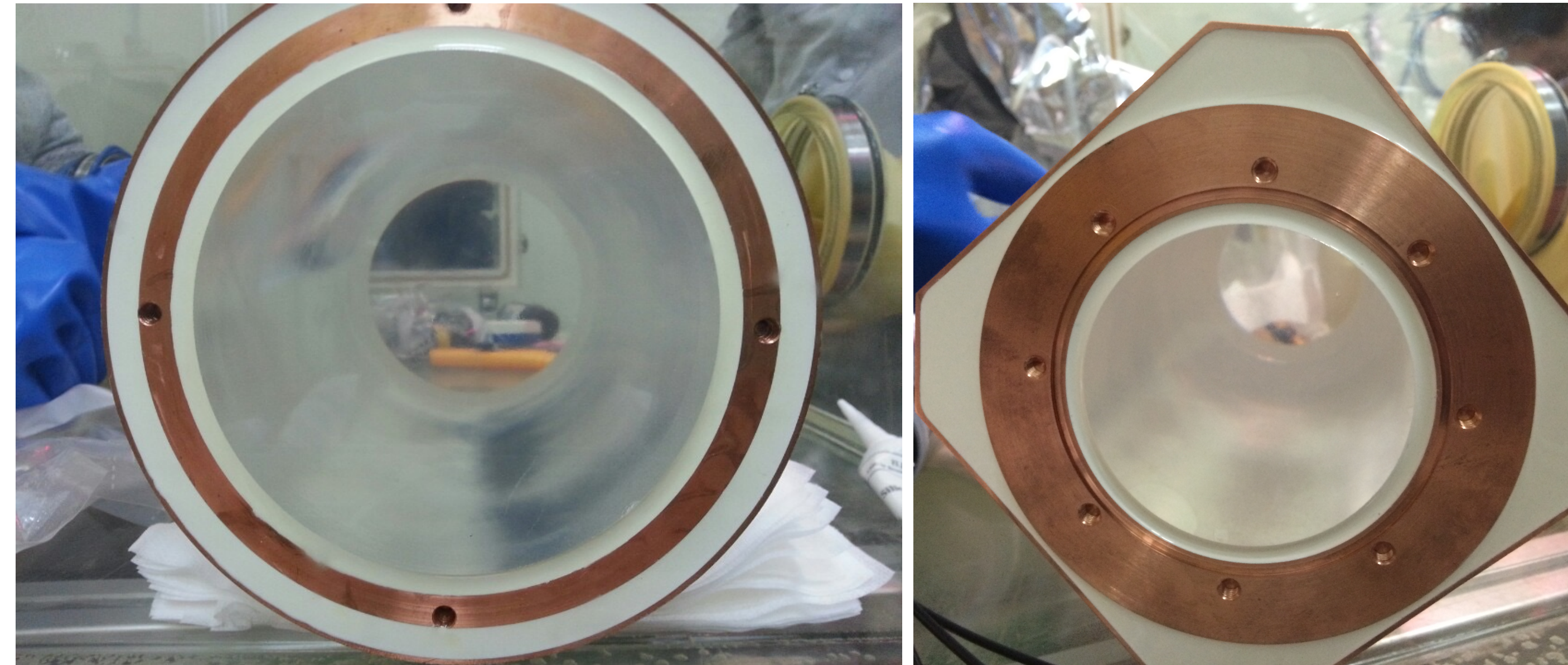

Crystal	Mass (kg)	Size (inches diameter × length)	Powder	α Rate (mBq/kg)	^{40}K (ppb)	^{238}U (ppt)	^{232}Th (ppt)	Light Yield (PEs/keV)
Crystal-1	8.3	5.0 × 7.0	AS-B	3.20 ± 0.08	43.4 ± 13.7	<0.02	1.3 ± 0.4	14.9 ± 1.5
Crystal-2	9.2	4.2 × 11.0	AS-C	2.06 ± 0.06	82.7 ± 12.7	<0.12	<0.6	14.6 ± 1.5
Crystal-3	9.2	4.2 × 11.0	AS-WSII	0.76 ± 0.02	41.1 ± 6.8	<0.04	0.4 ± 0.2	15.5 ± 1.6
Crystal-4	18.0	5.0 × 15.3	AS-WSII	0.74 ± 0.02	39.5 ± 8.3		<0.3	14.9 ± 1.5
Crystal-5	18.3	5.0 × 15.5	AS-C	2.06 ± 0.05	86.8 ± 10.8		2.4 ± 0.3	7.3 ± 0.7
Crystal-6	12.5	4.8 × 11.8	AS-WSIII	1.52 ± 0.04	12.2 ± 4.5	<0.02	0.6 ± 0.2	14.6 ± 1.5
Crystal-7	12.5	4.8 × 11.8	AS-WSIII	1.54 ± 0.04	18.8 ± 5.3		<0.6	14.0 ± 1.4
Crystal-8	18.3	5.0 × 15.5	AS-C	2.05 ± 0.05	56.2 ± 8.1		<1.4	3.5 ± 0.3
DAMA				< 0.5	< 20	0.7–10	0.5–7.5	5.5–7.5

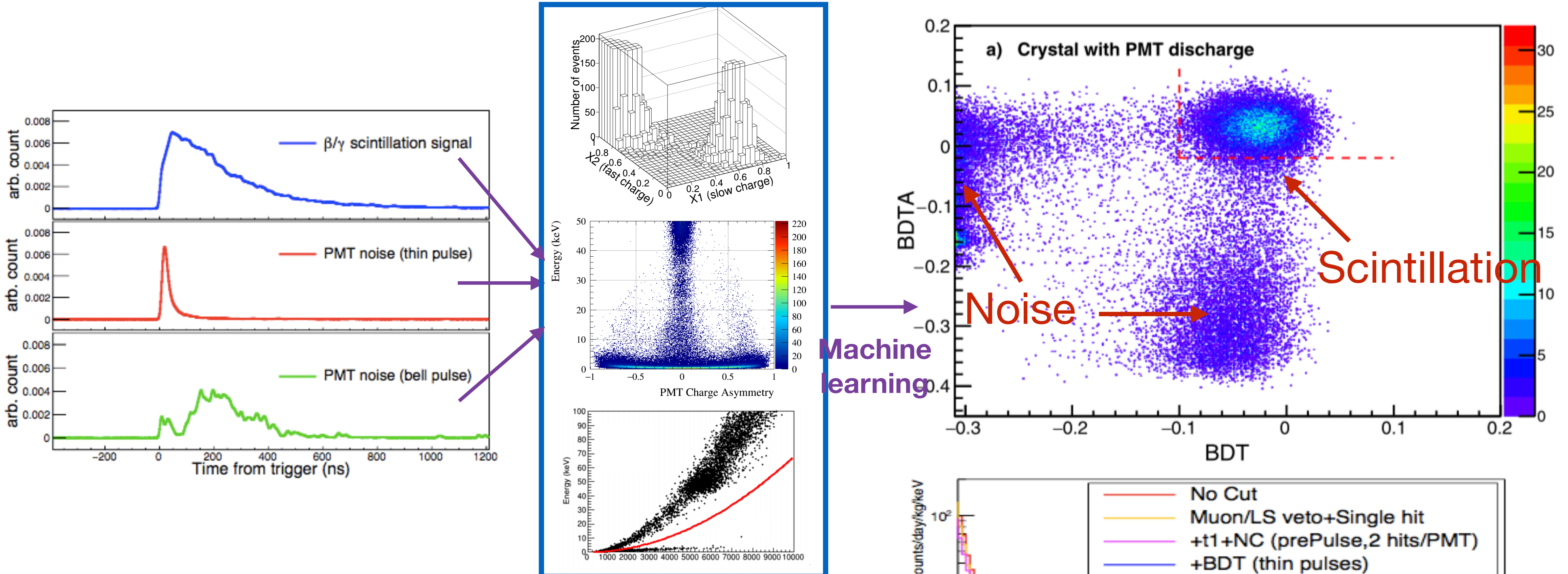

- Dominant source of noise events comes from PMT noise
- Boosted Decision Tree (BDT) was utilized to reject such noise events

PMT noise rejection: Charge Ratio

Eur.Phys.J. C 78 107 (2018)

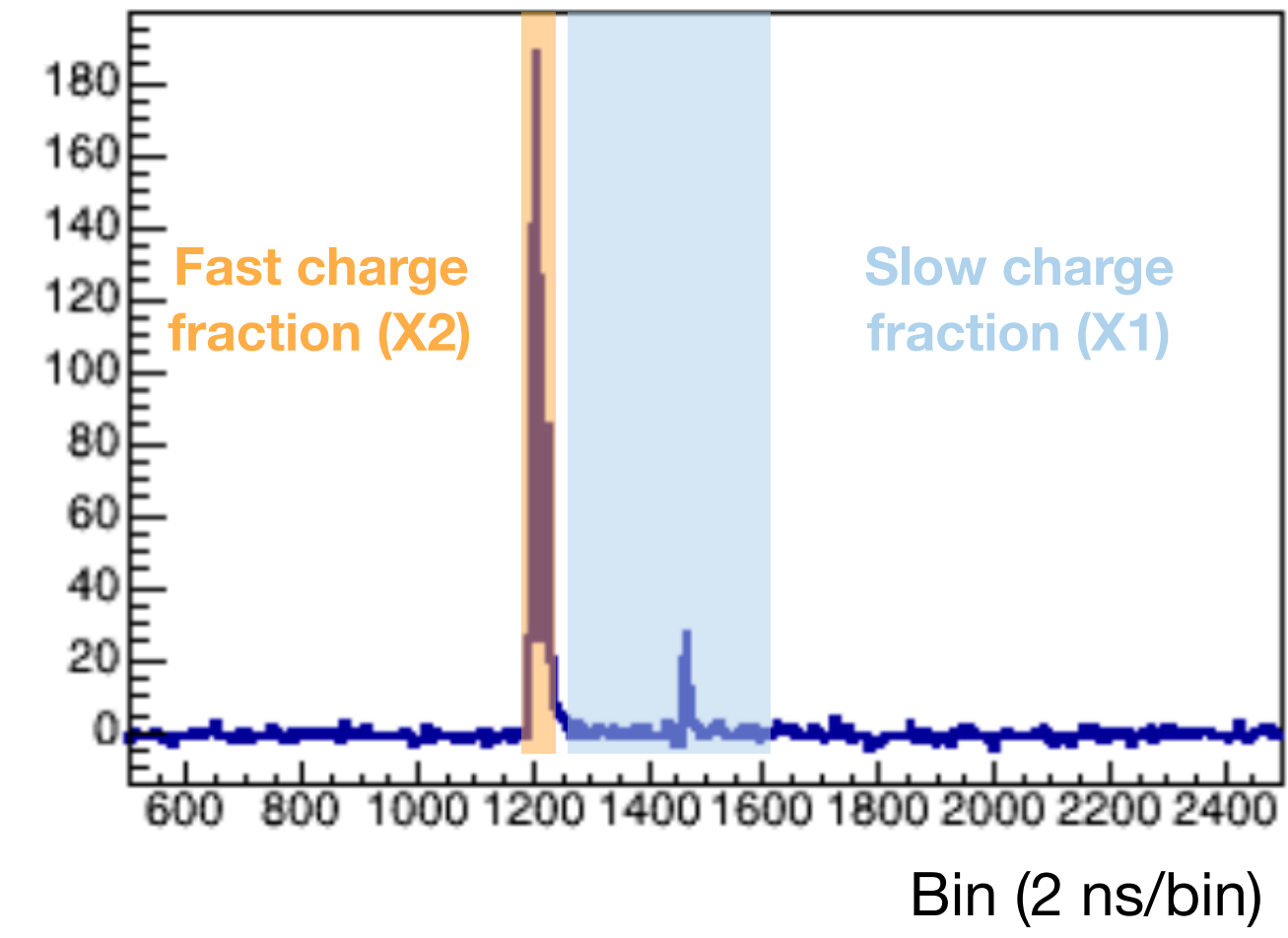
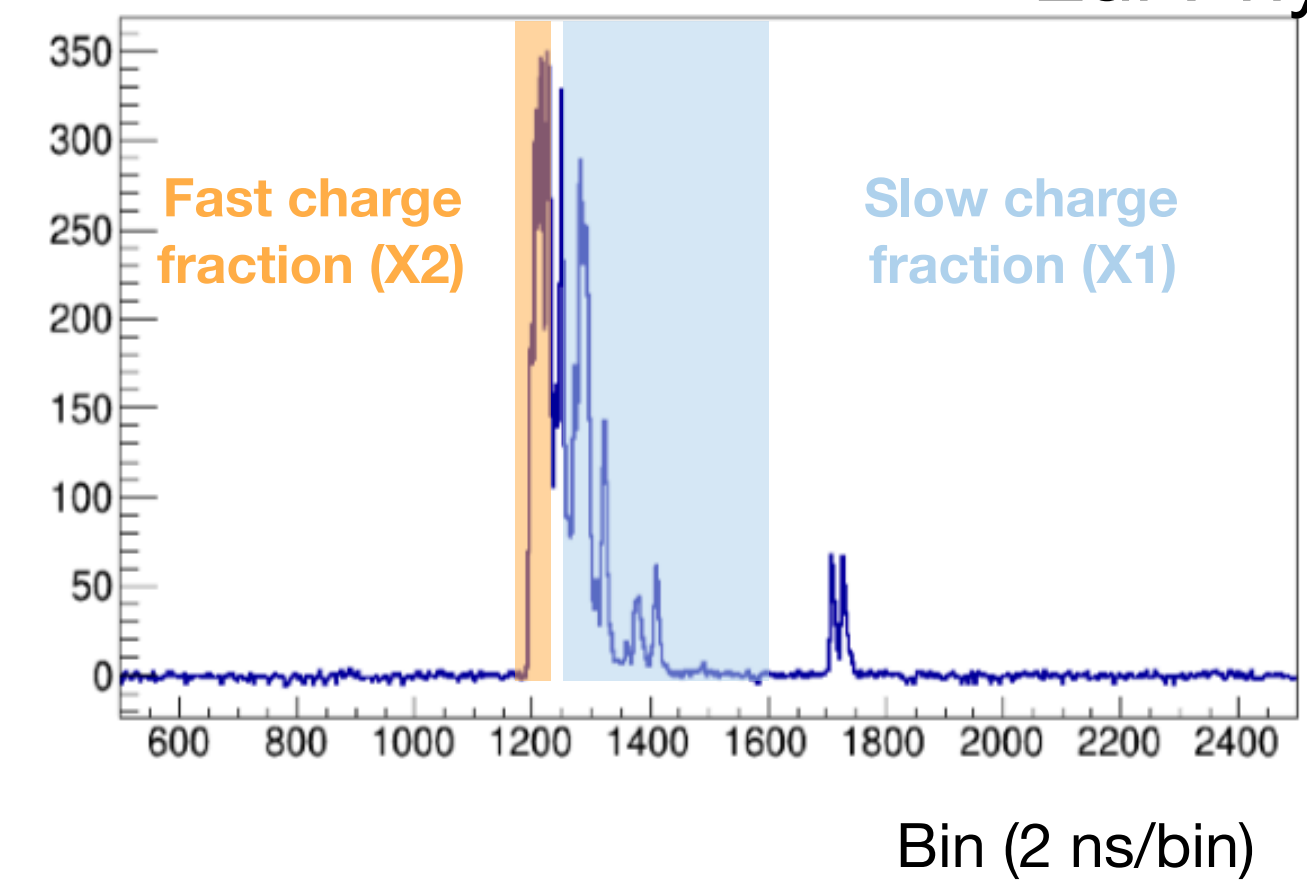
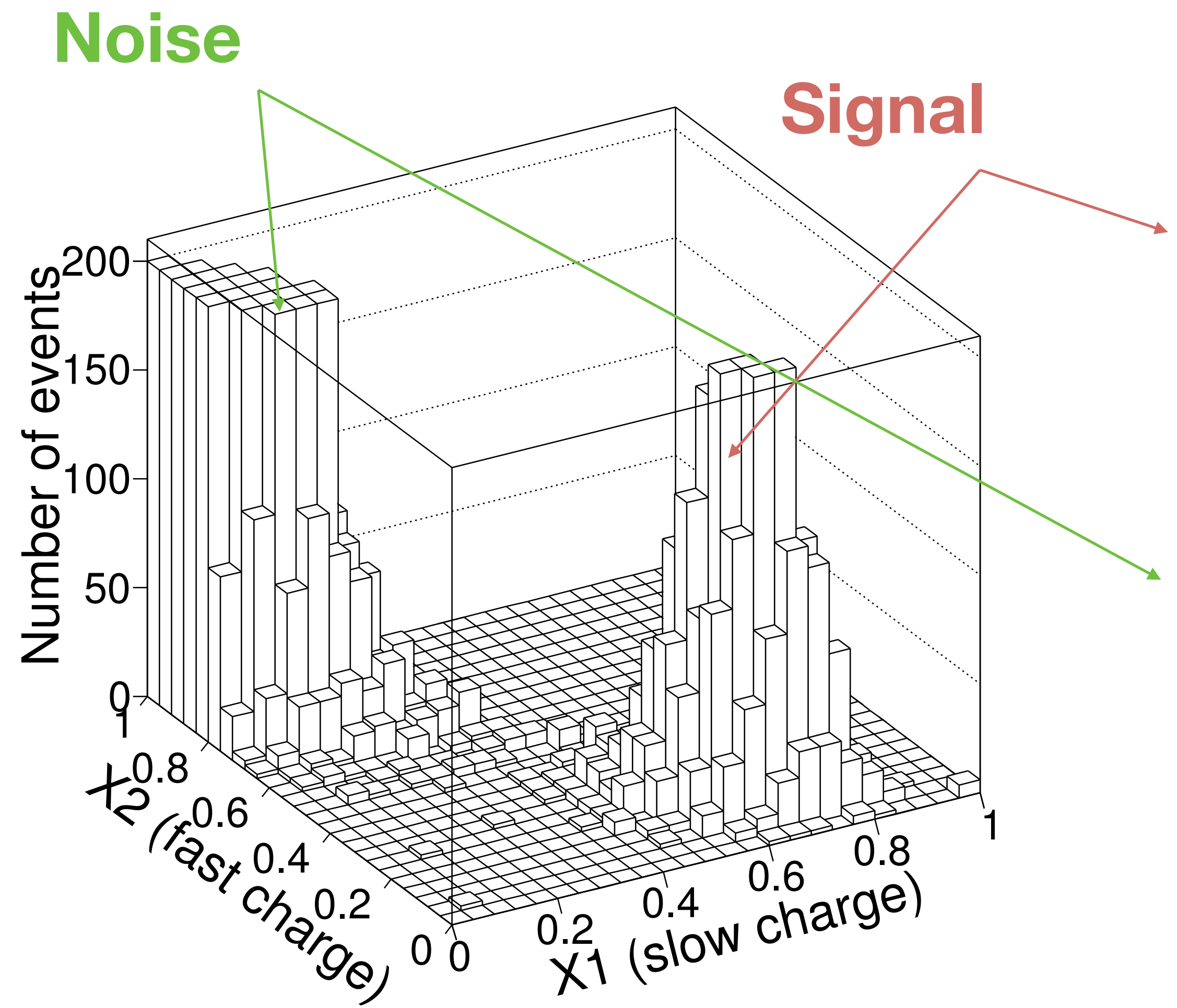

Looking at charge ratio between rising edge and falling edge of a pulse gives good noise separation power

PMT noise rejection: Asymmetry and Charge/Peak

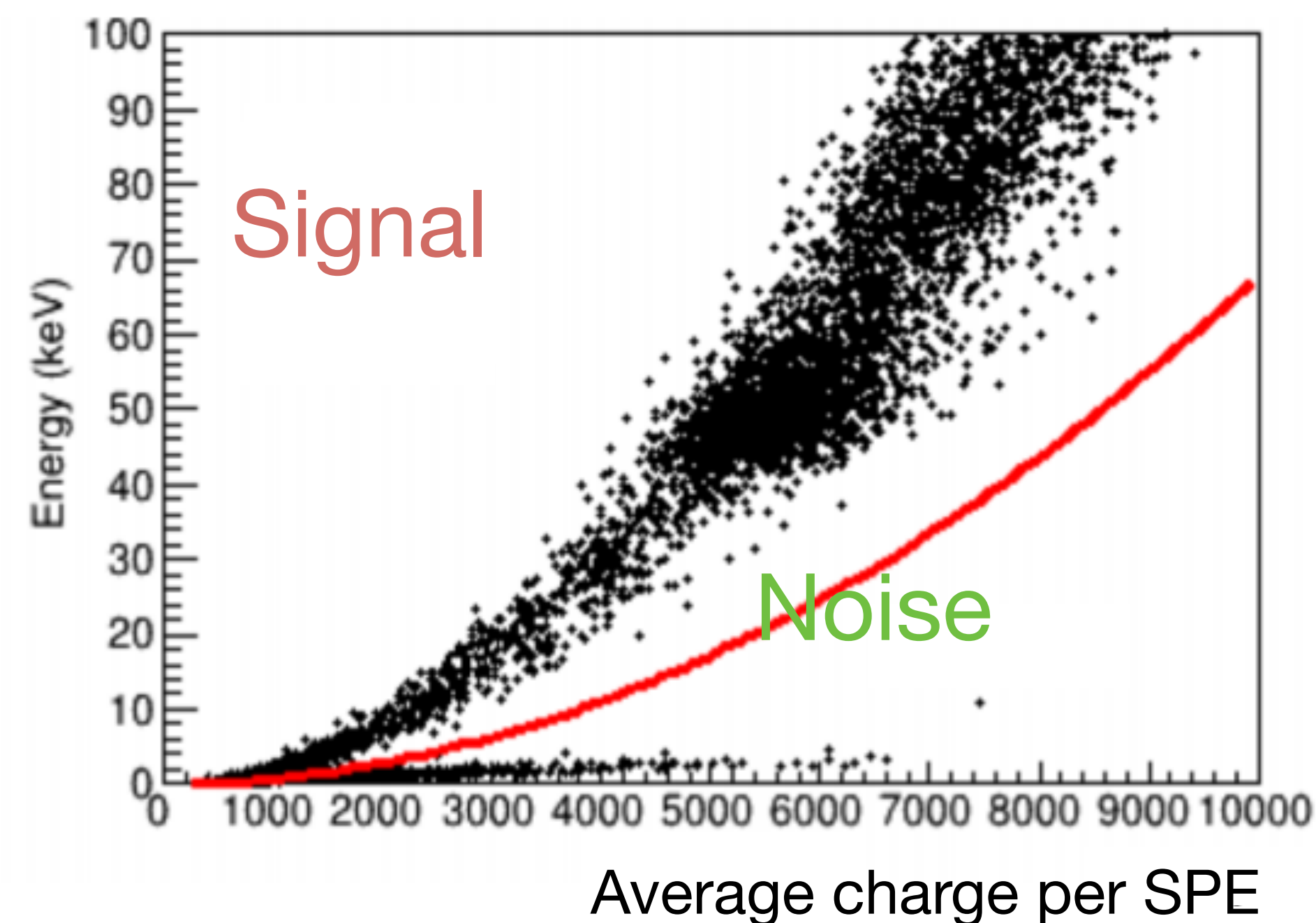
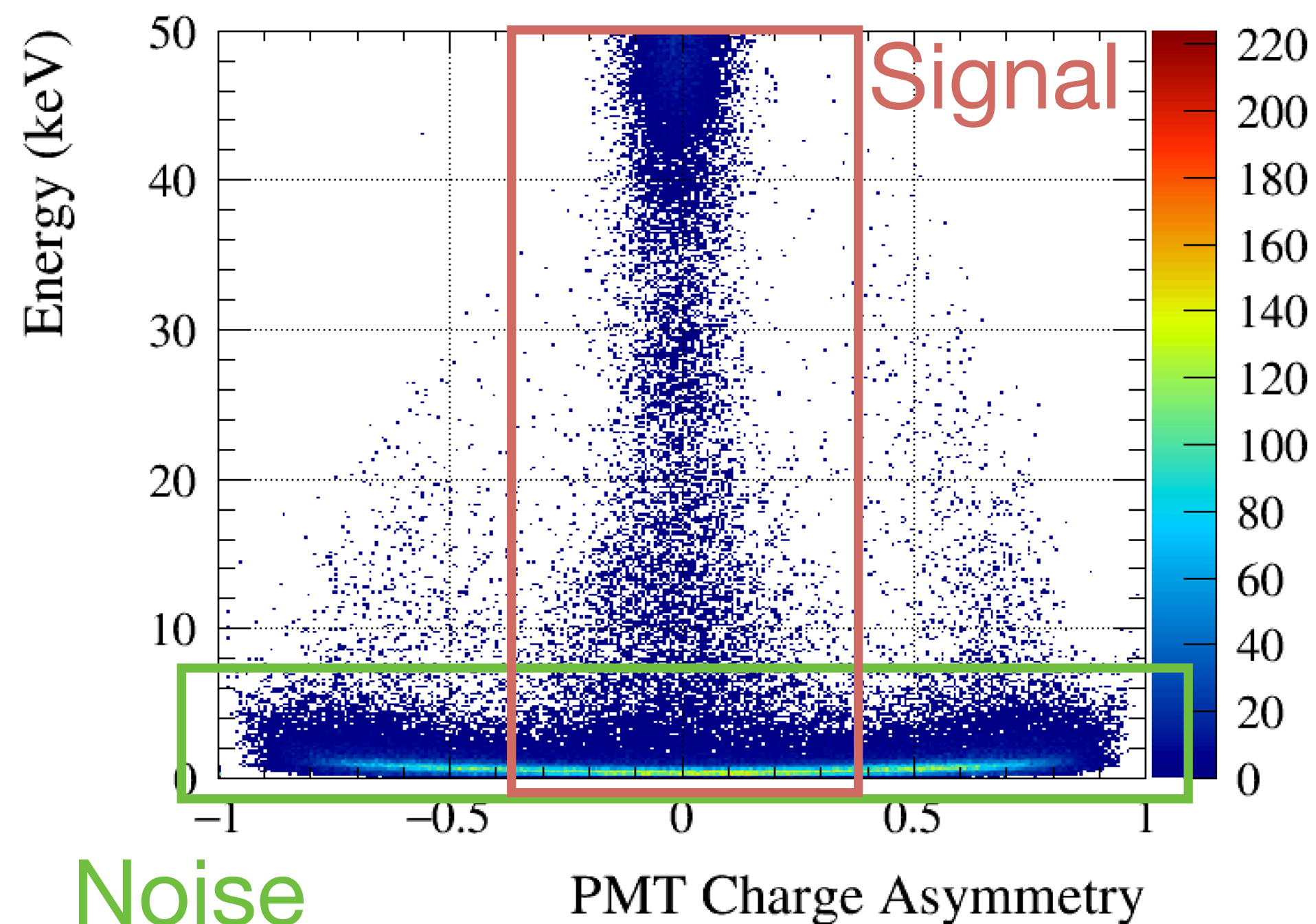

- Additional noise reduction cuts have been developed:
 - Charge asymmetry between 2 PMTs in each crystal
 - Charge/peak: Average charge per SPE

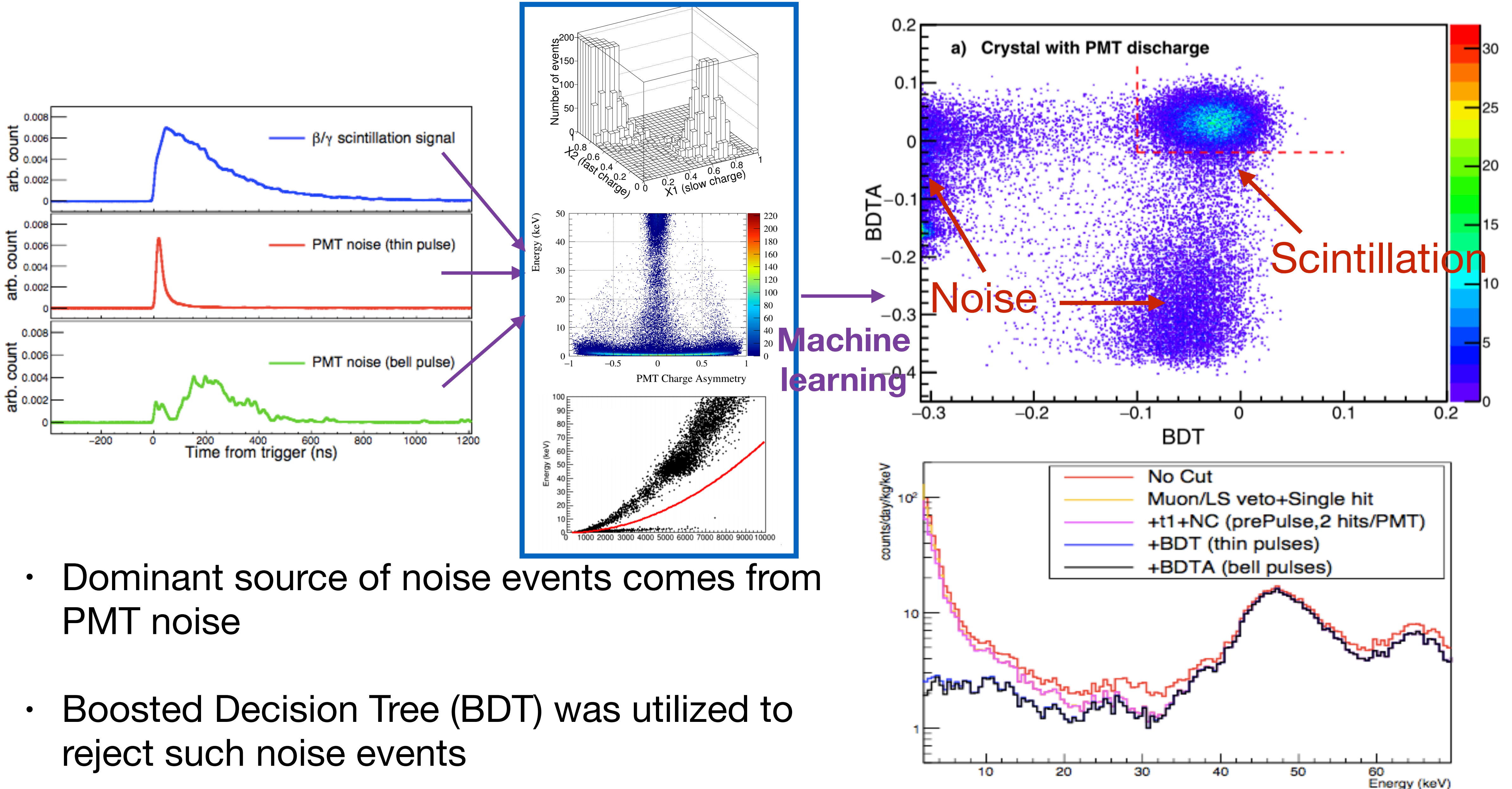

- Dominant source of noise events comes from PMT noise
- Boosted Decision Tree (BDT) was utilized to reject such noise events

Selection efficiency/Low energy spectrum

Nature **564**, 83-86 (2018)

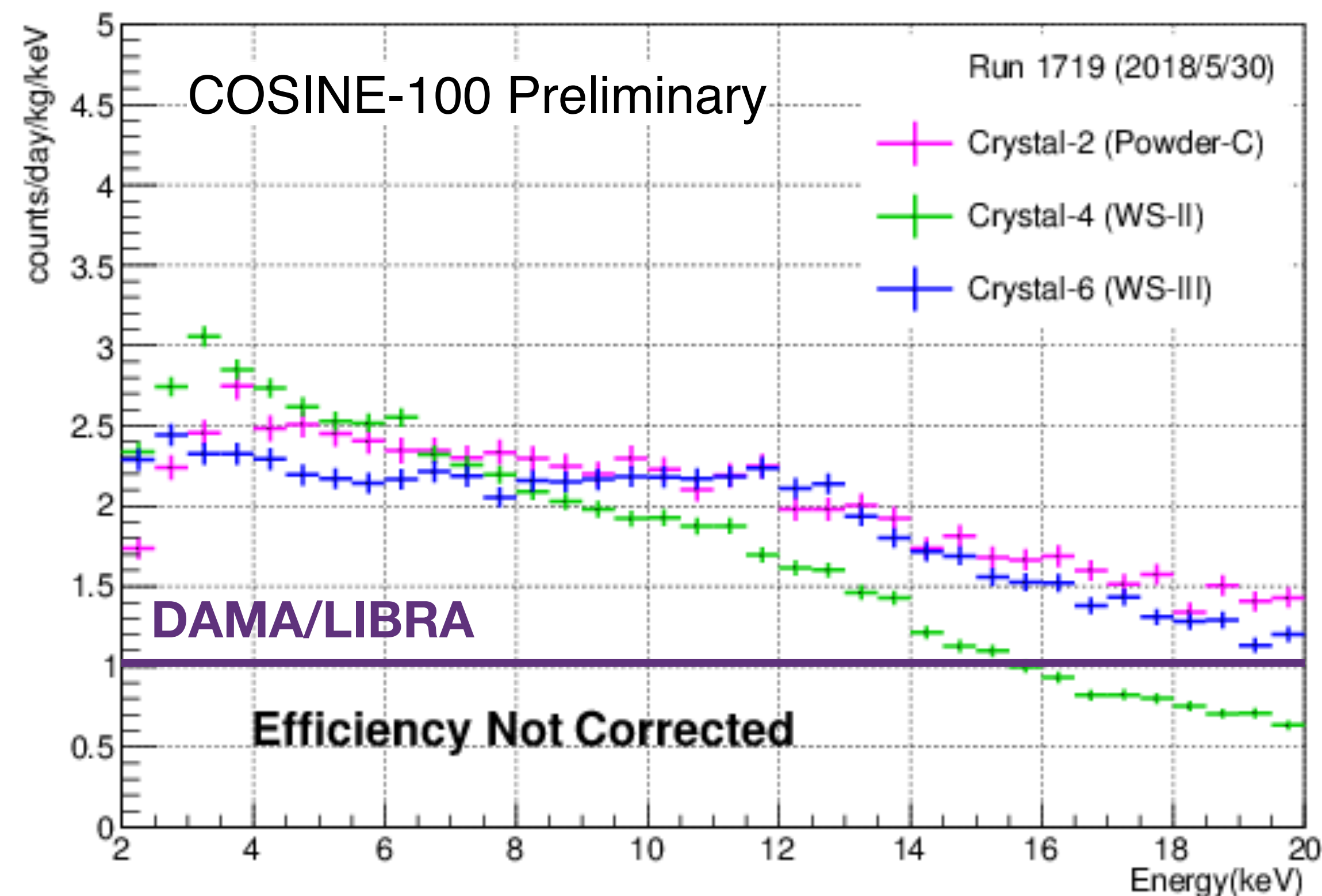
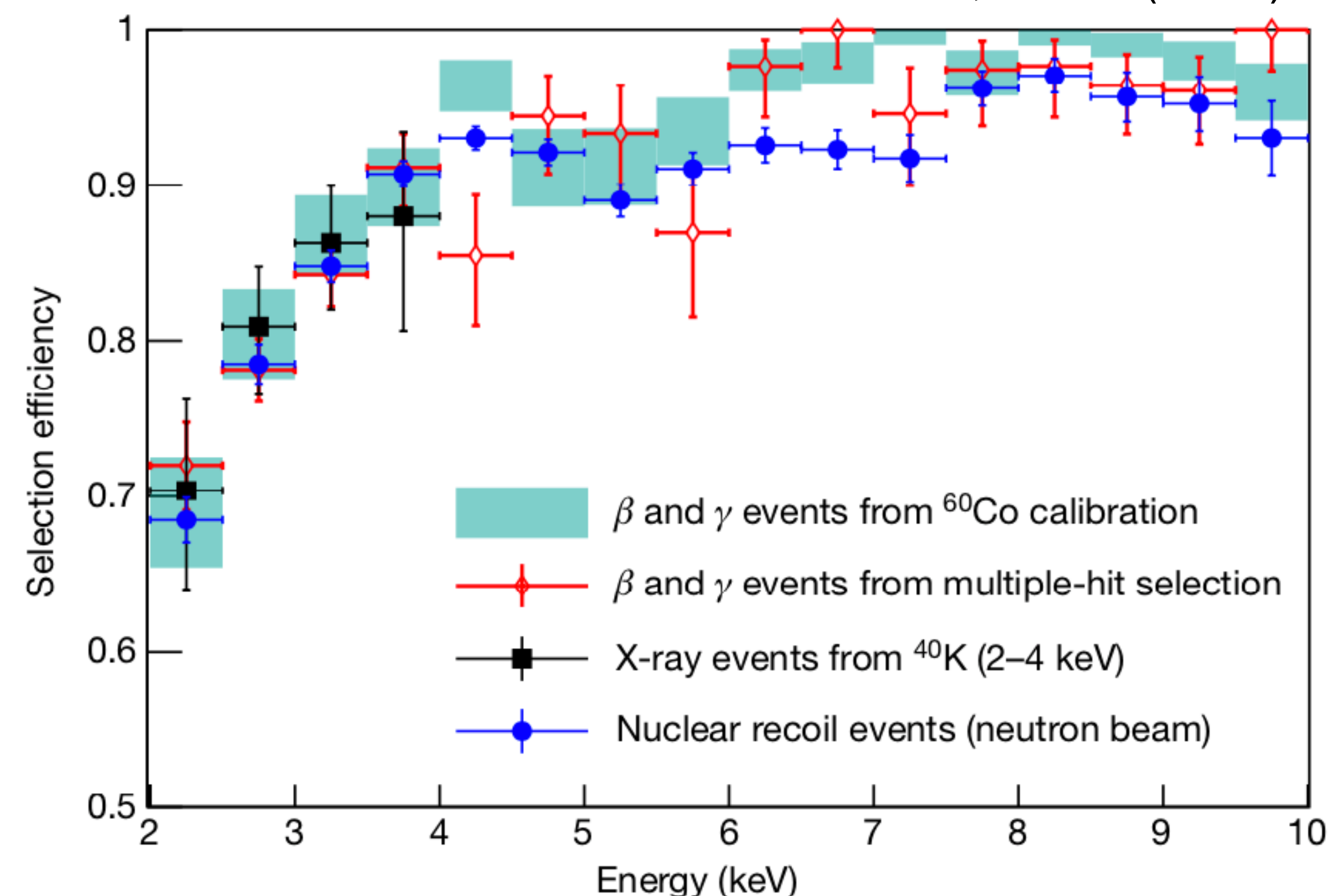

- ~70% efficiency at 2 keV
- 2 - 4 counts/keV/kg/day in region of interest depending on the crystal

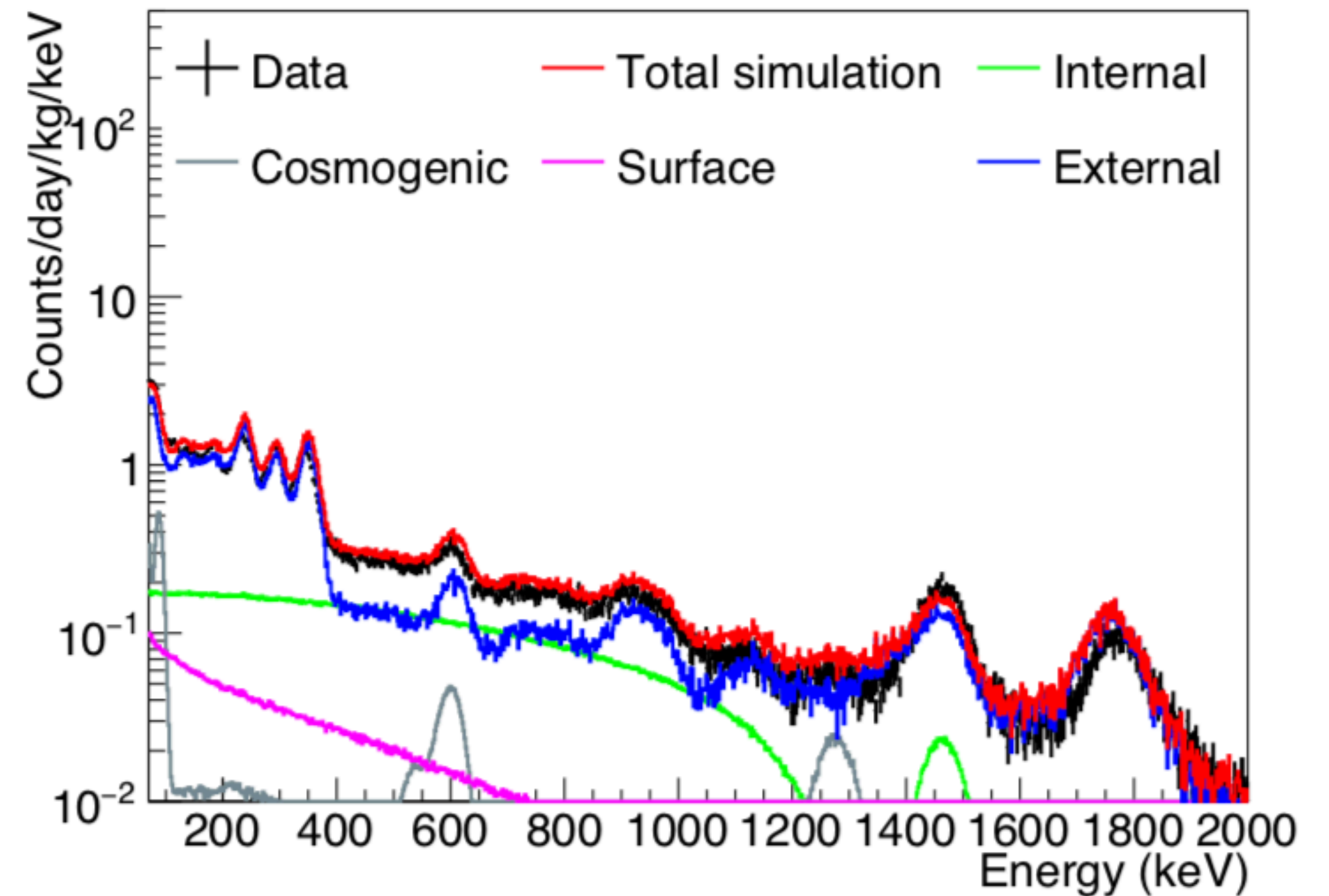
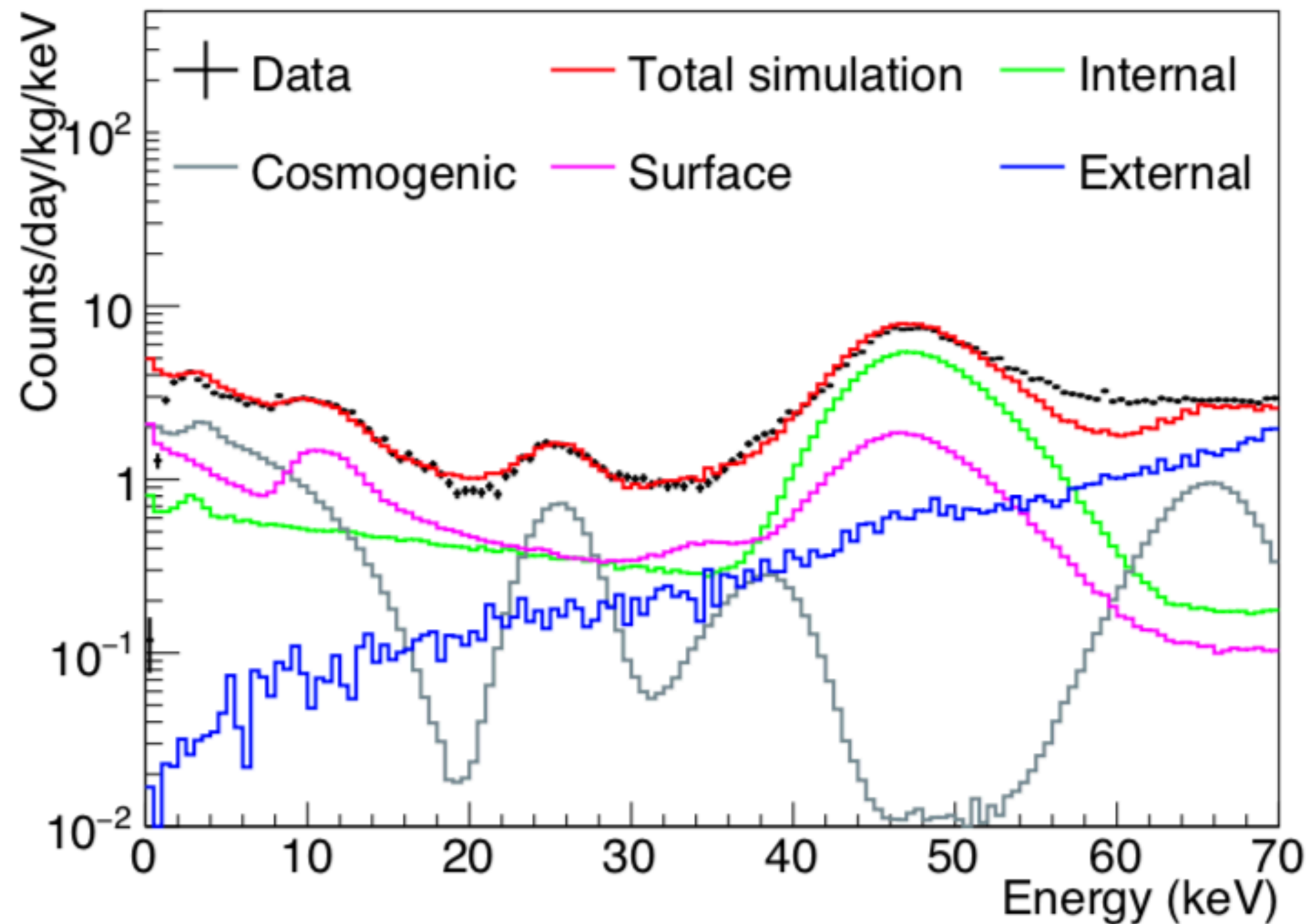

- Data reproduced well with Geant4 simulation
- **Background well understood from 2 keV - 2000 keV**
- Dominant background from ^{210}Pb (internal, surface) and ^{40}K (internal), followed by cosmogenic ^3H

Single-hit

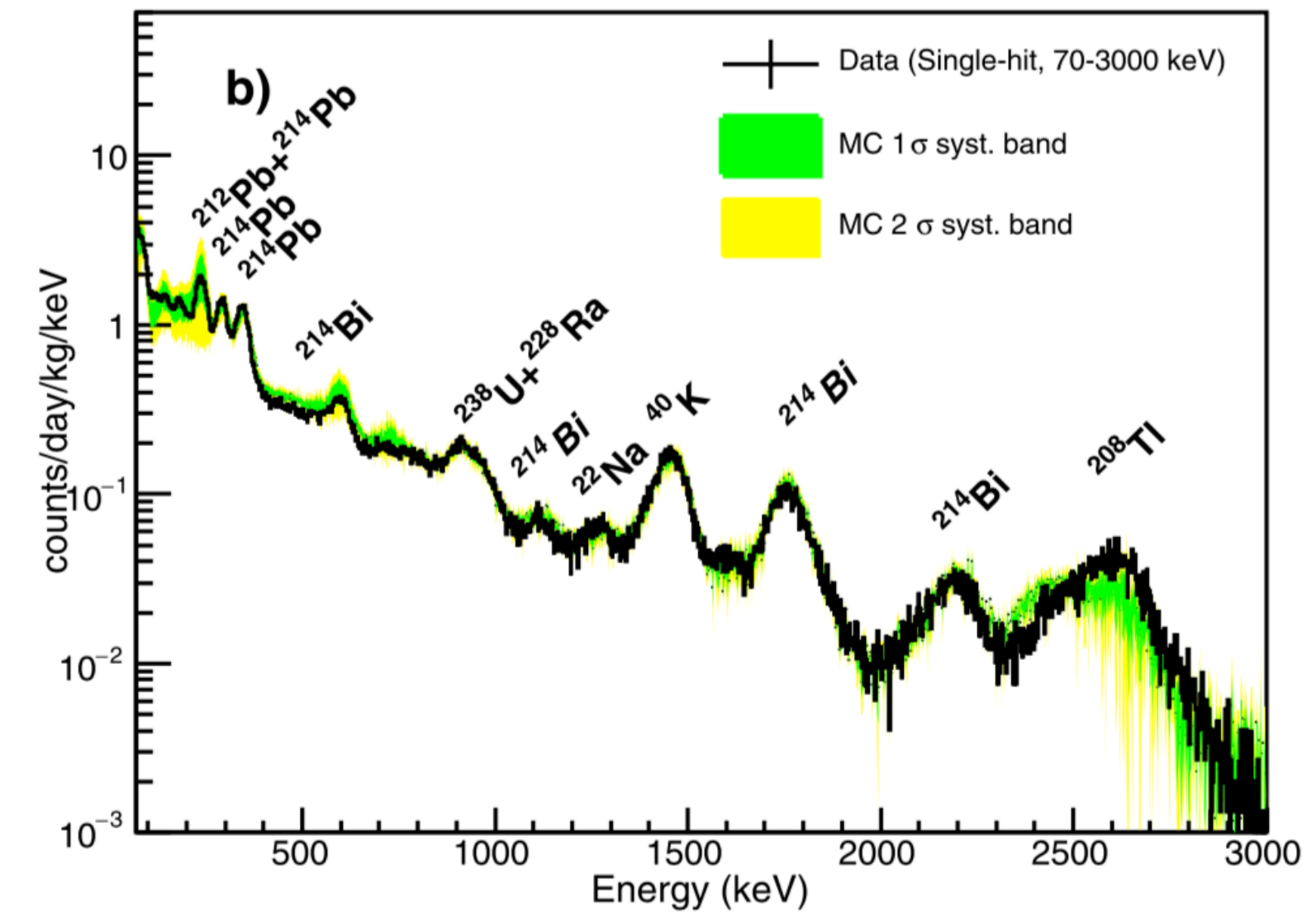
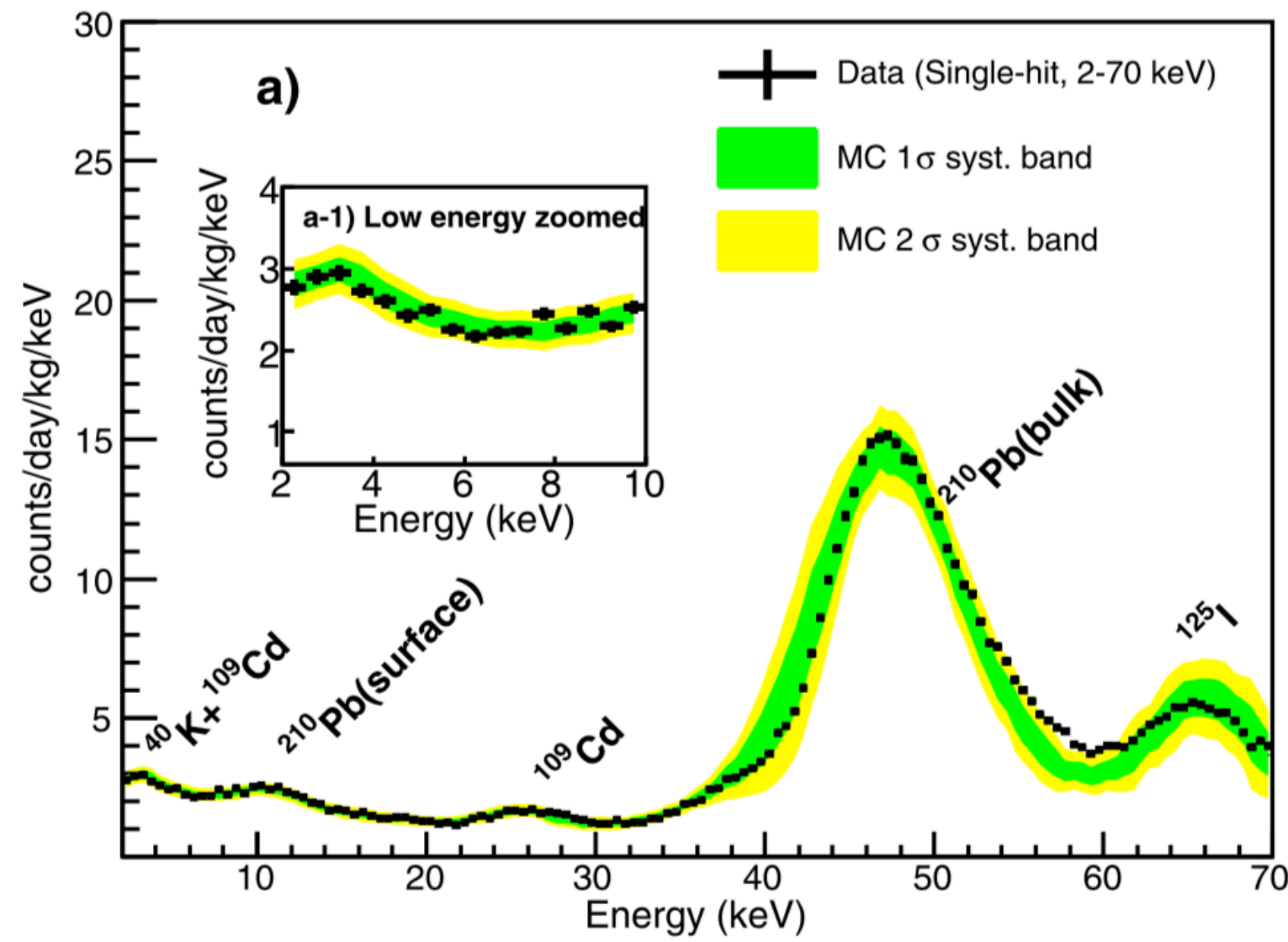

Multiple-hit

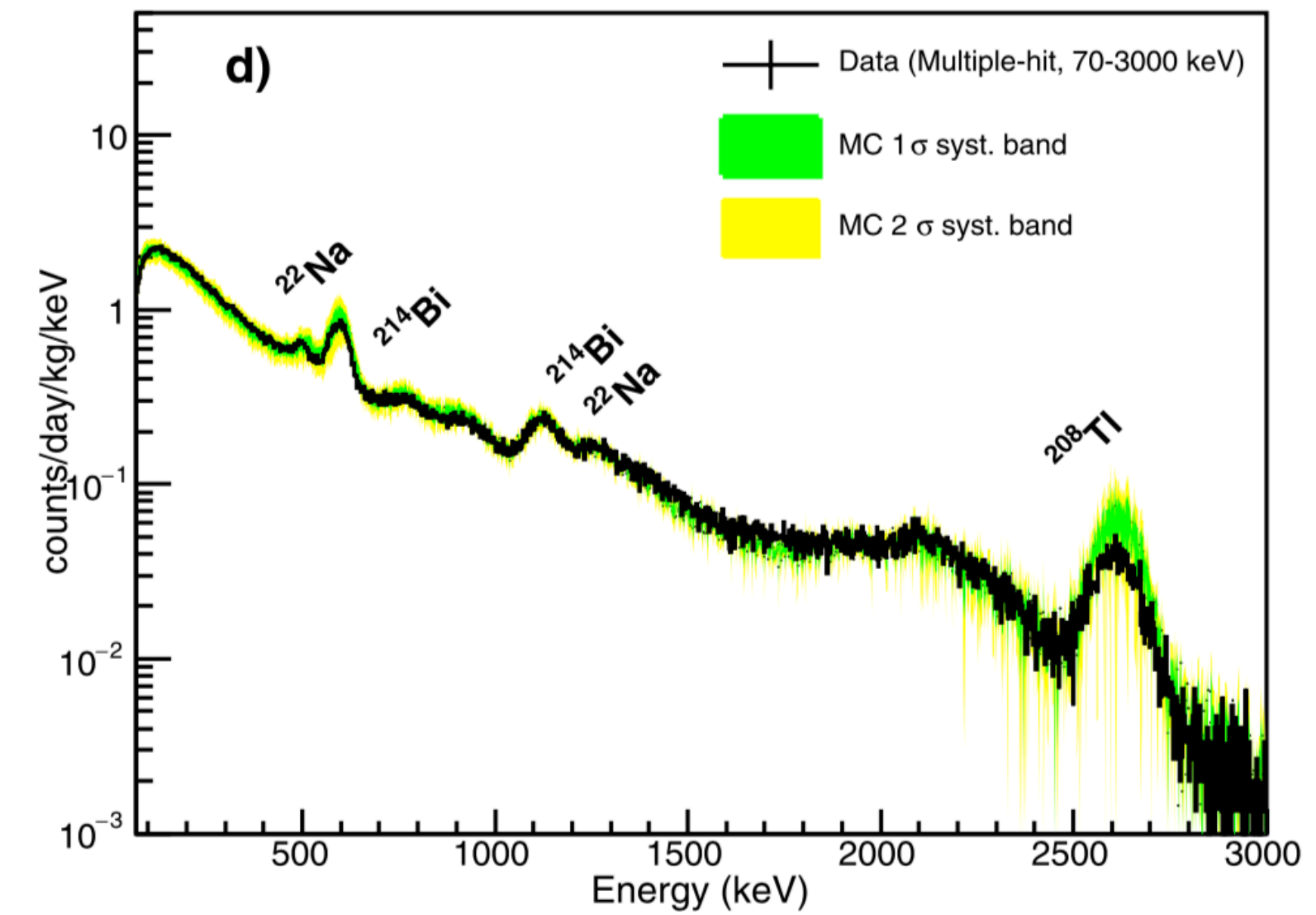
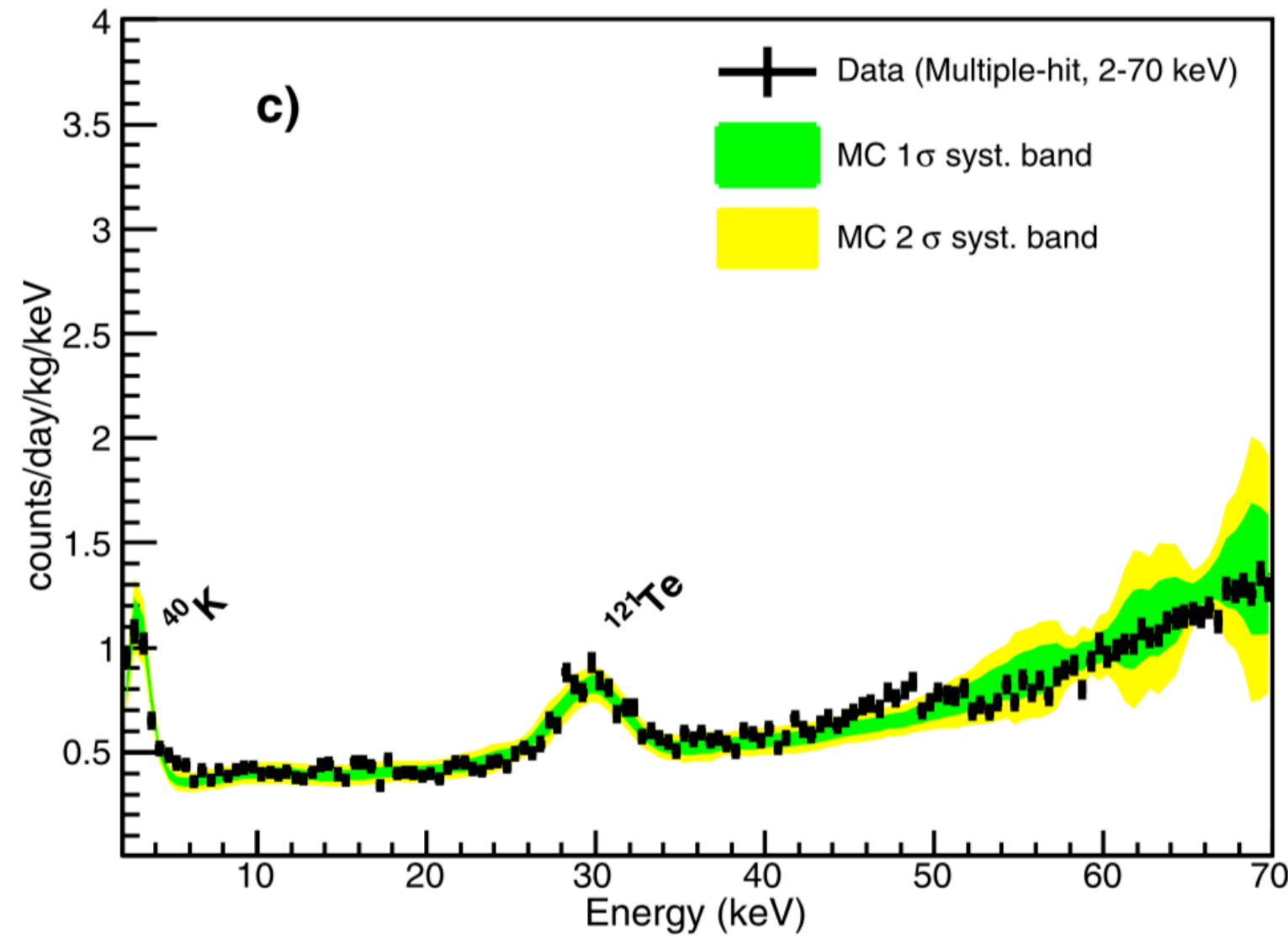

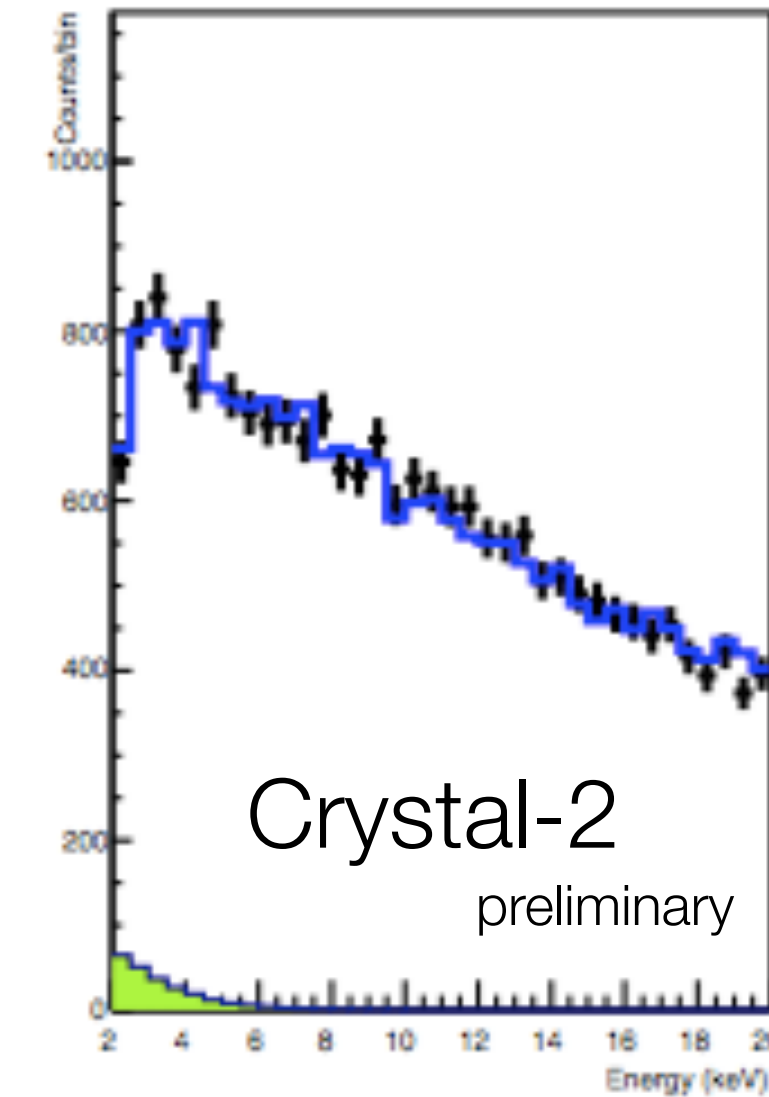
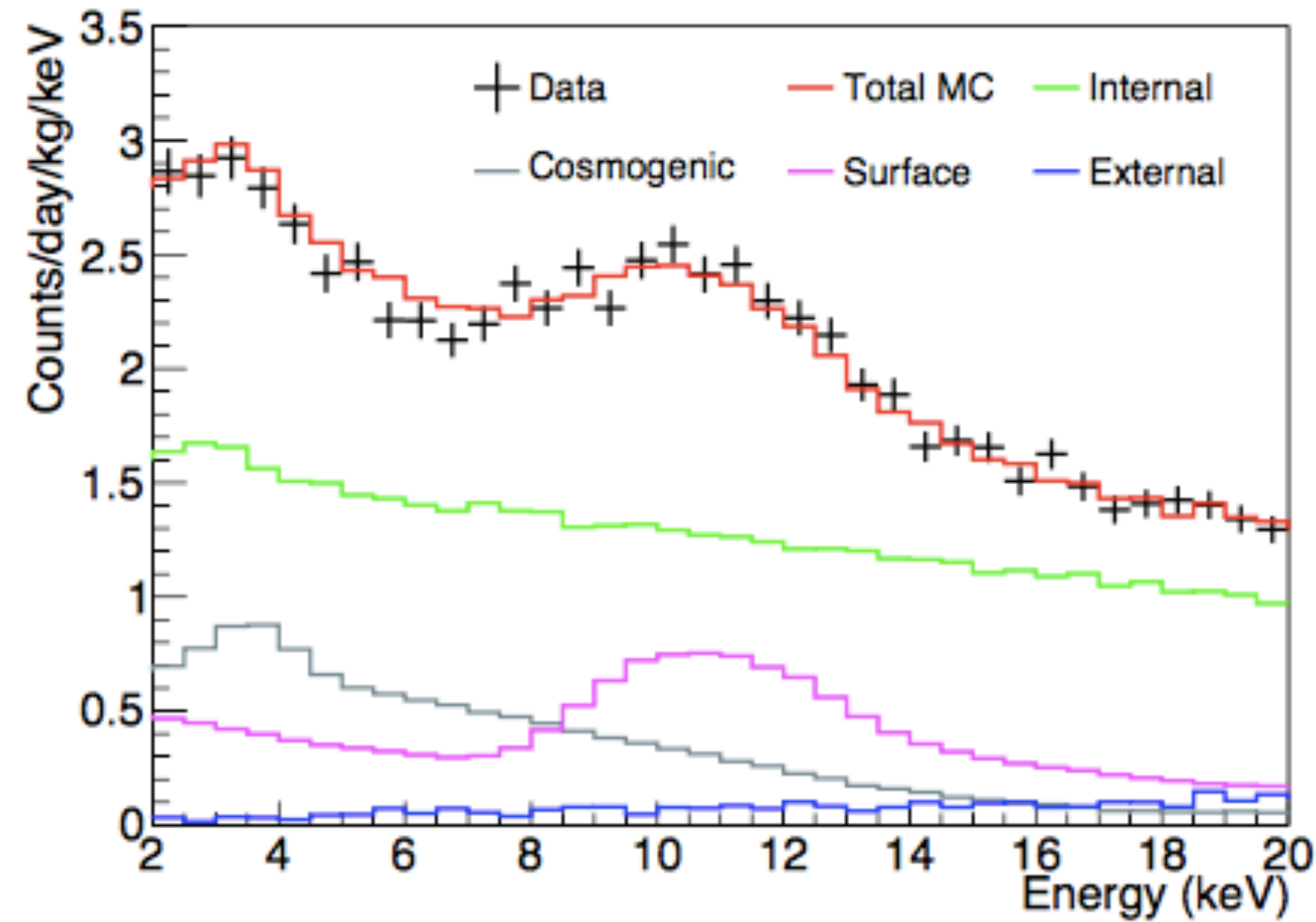

C6_Data_Spectrum

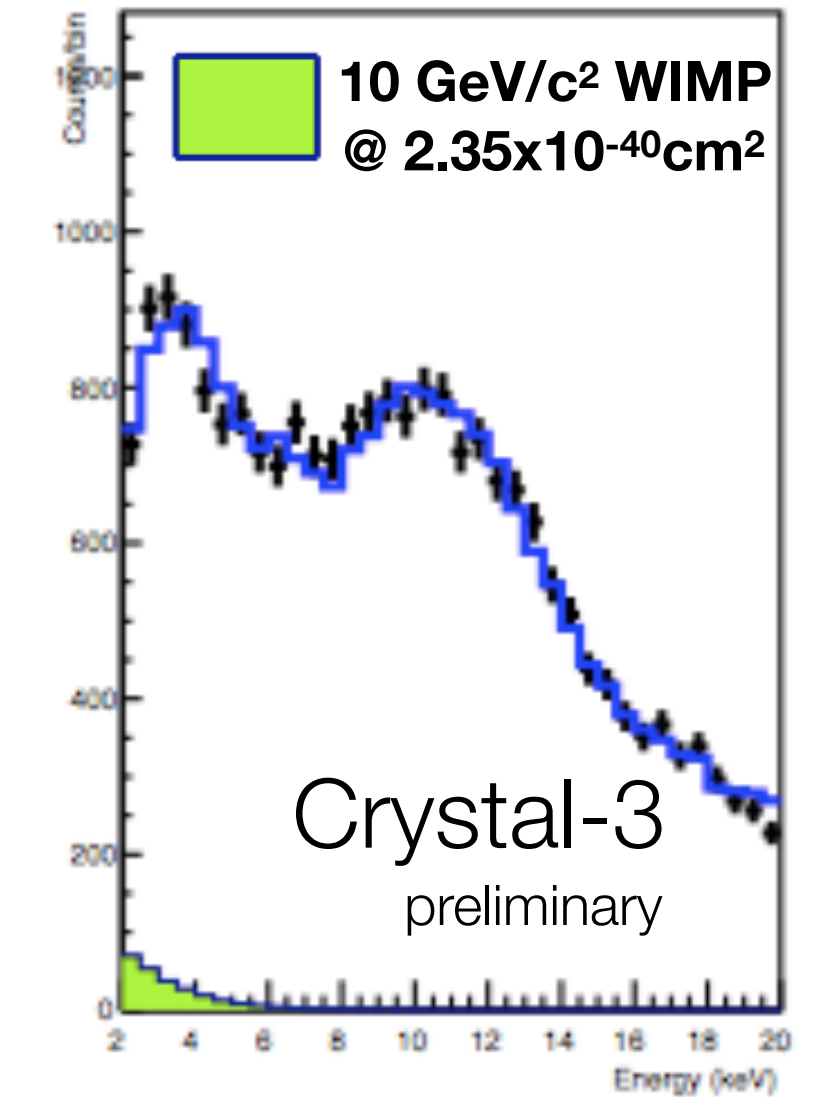

C7_Data_Spectrum

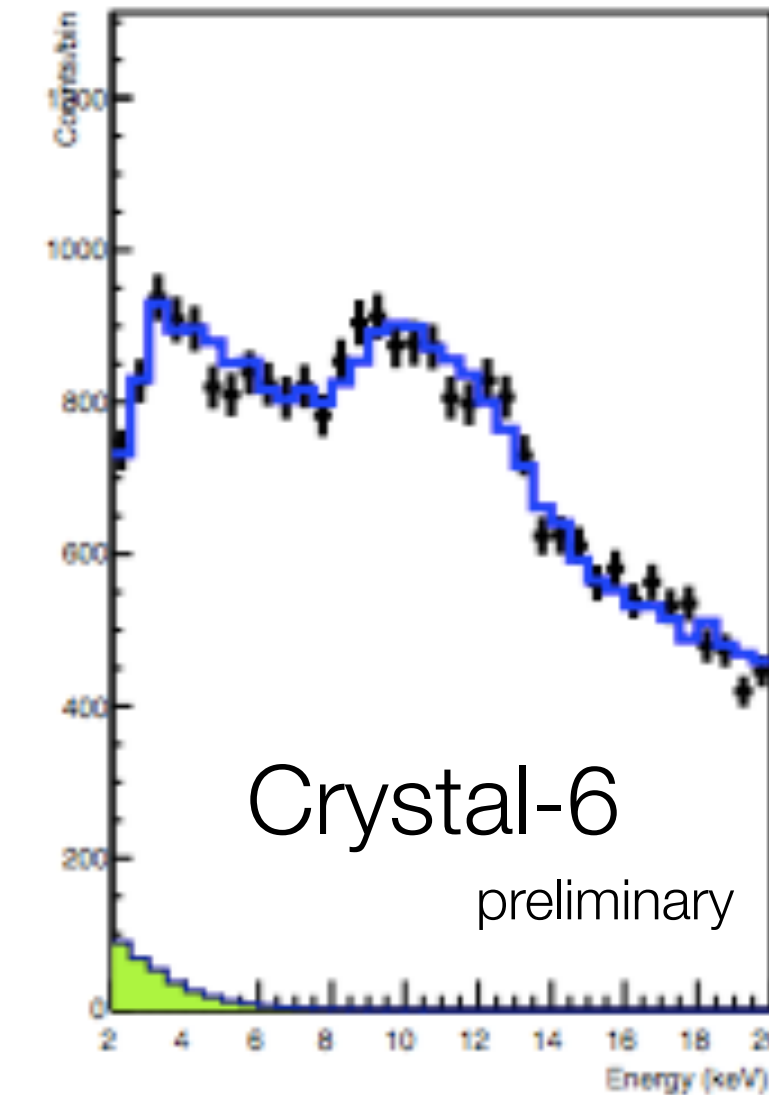

Crystal-6 preliminary

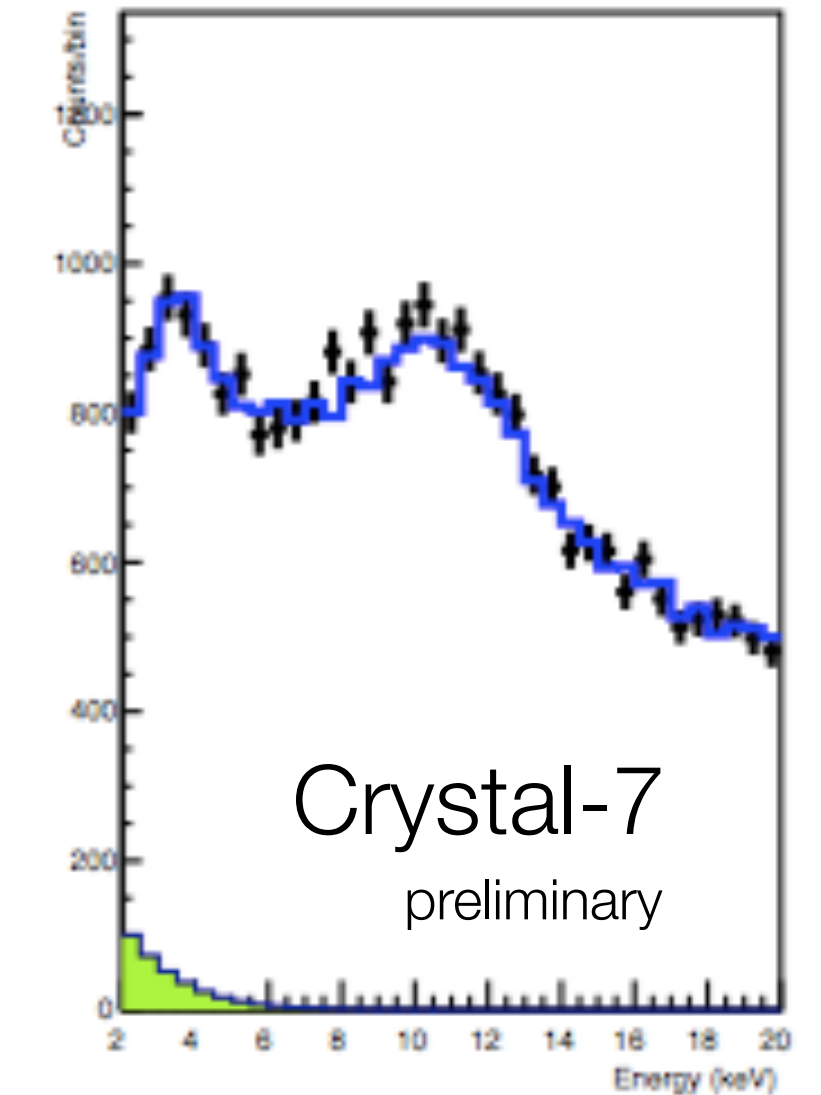

Crystal-7 preliminary

10 GeV/c² WIMP
@ 2.35x10⁻⁴⁰cm²

- Using 59.5 days of data: 6303.9 kg day exposure
- Spectrum fit for 2-20 keV including WIMP model
- Likelihood analysis to fit data using background model and WIMP signal model (SHM as described in Savage *et al.*, JCAP 0904:010, 2009)
- Background understanding consideration from V. Kudryavtsev *et al.* Astropart. Phys. **33** (2010) 91

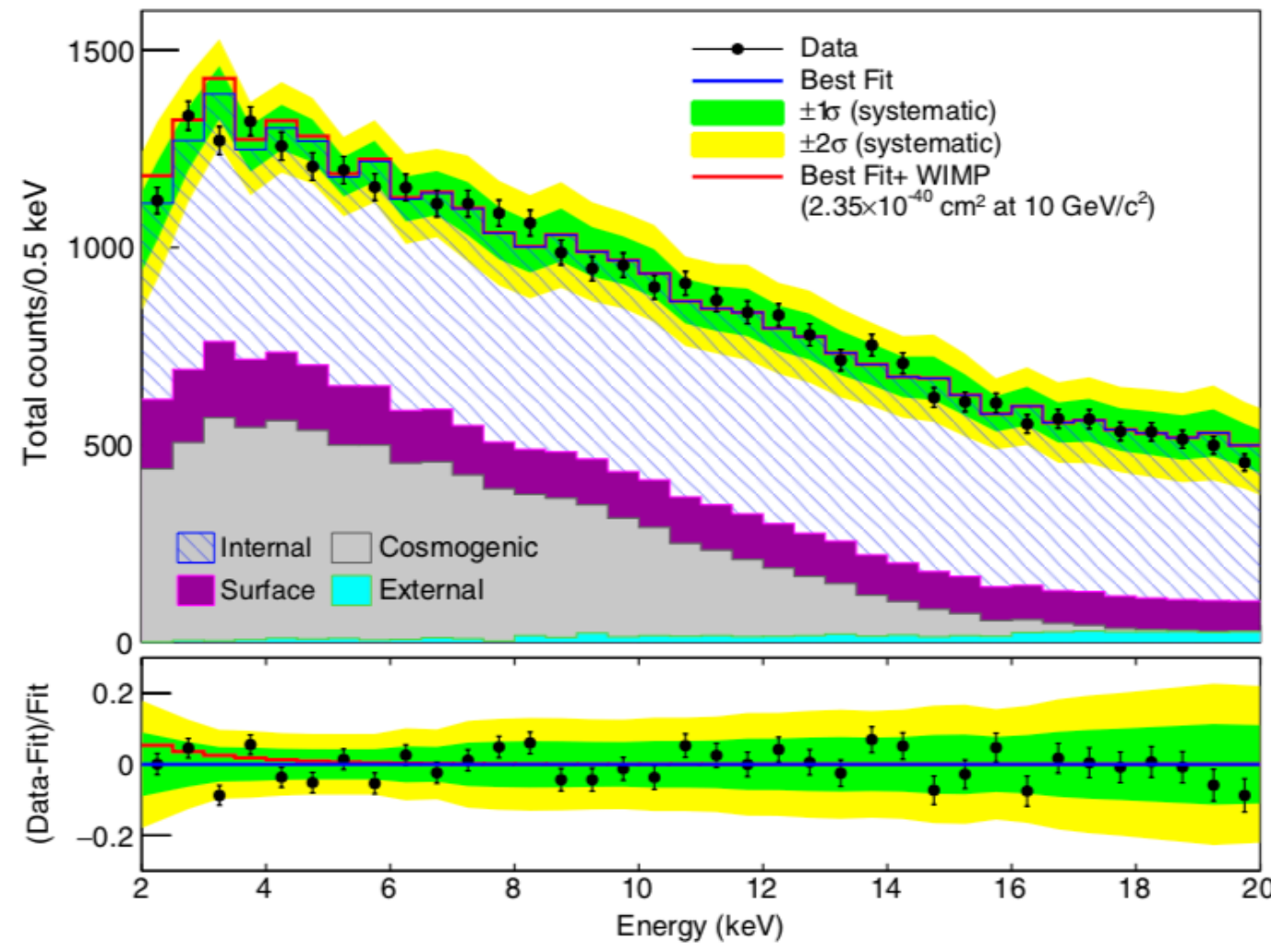

a) Crystal 1

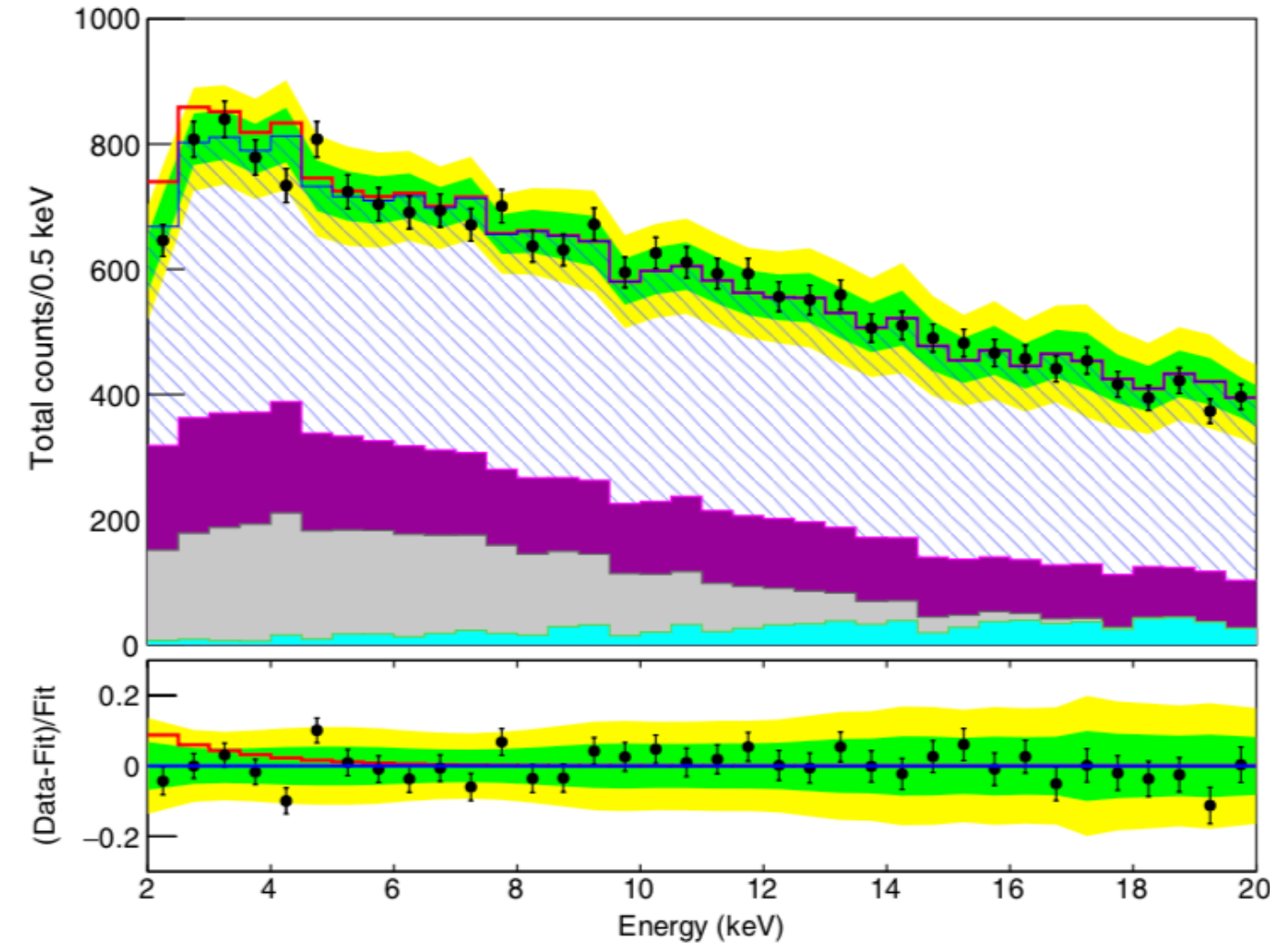

b) Crystal 2

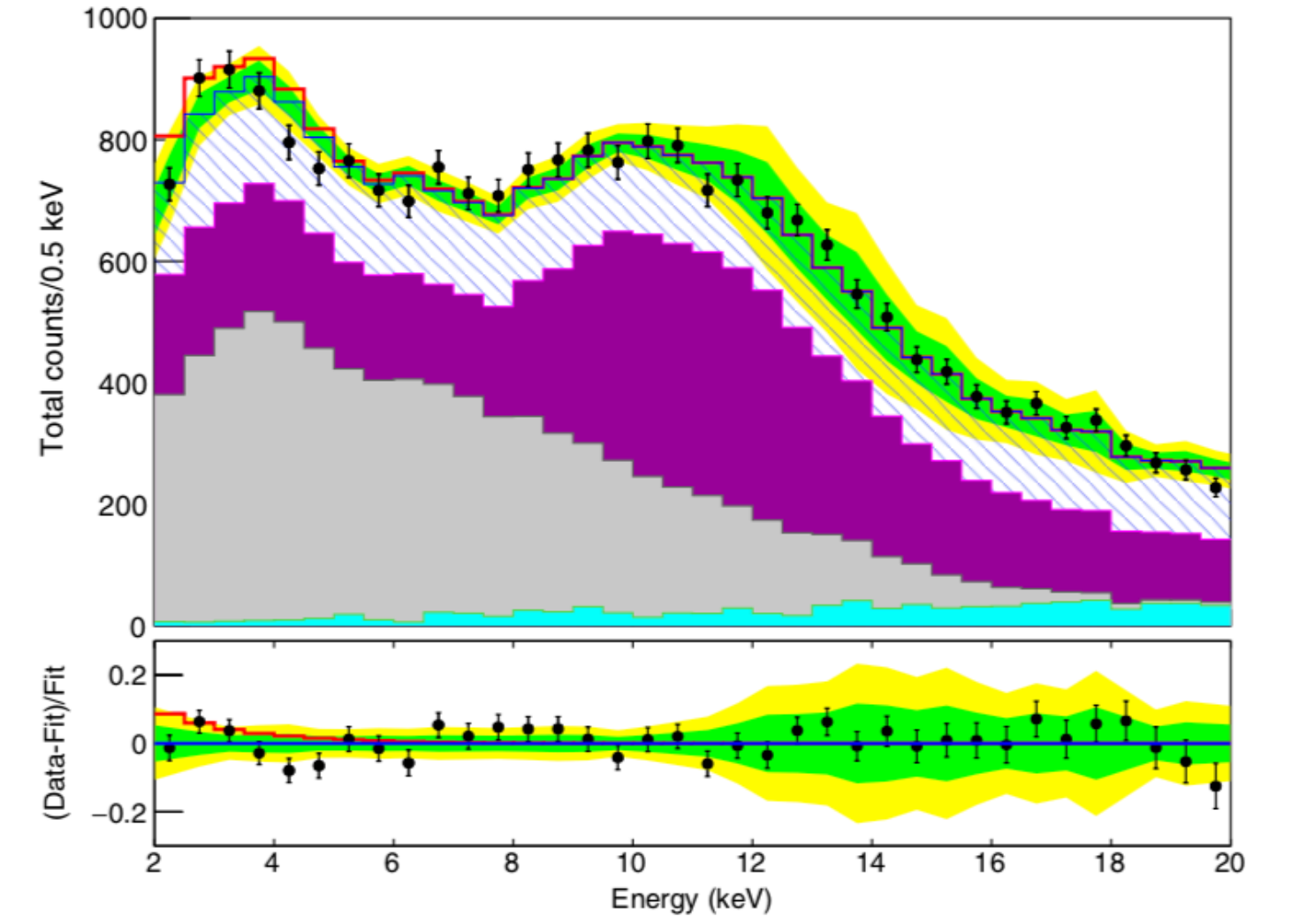

c) Crystal 3

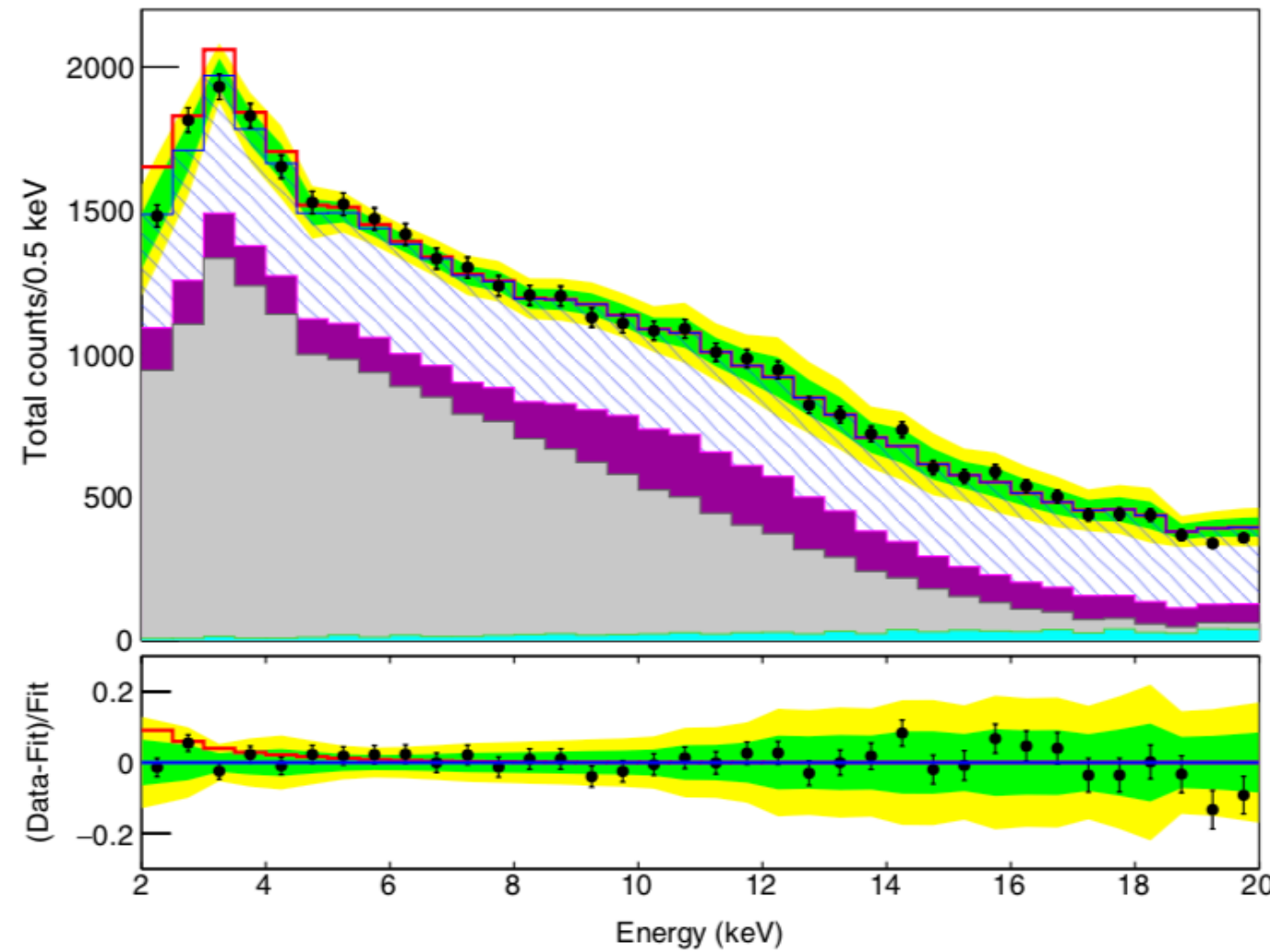

d) Crystal 4

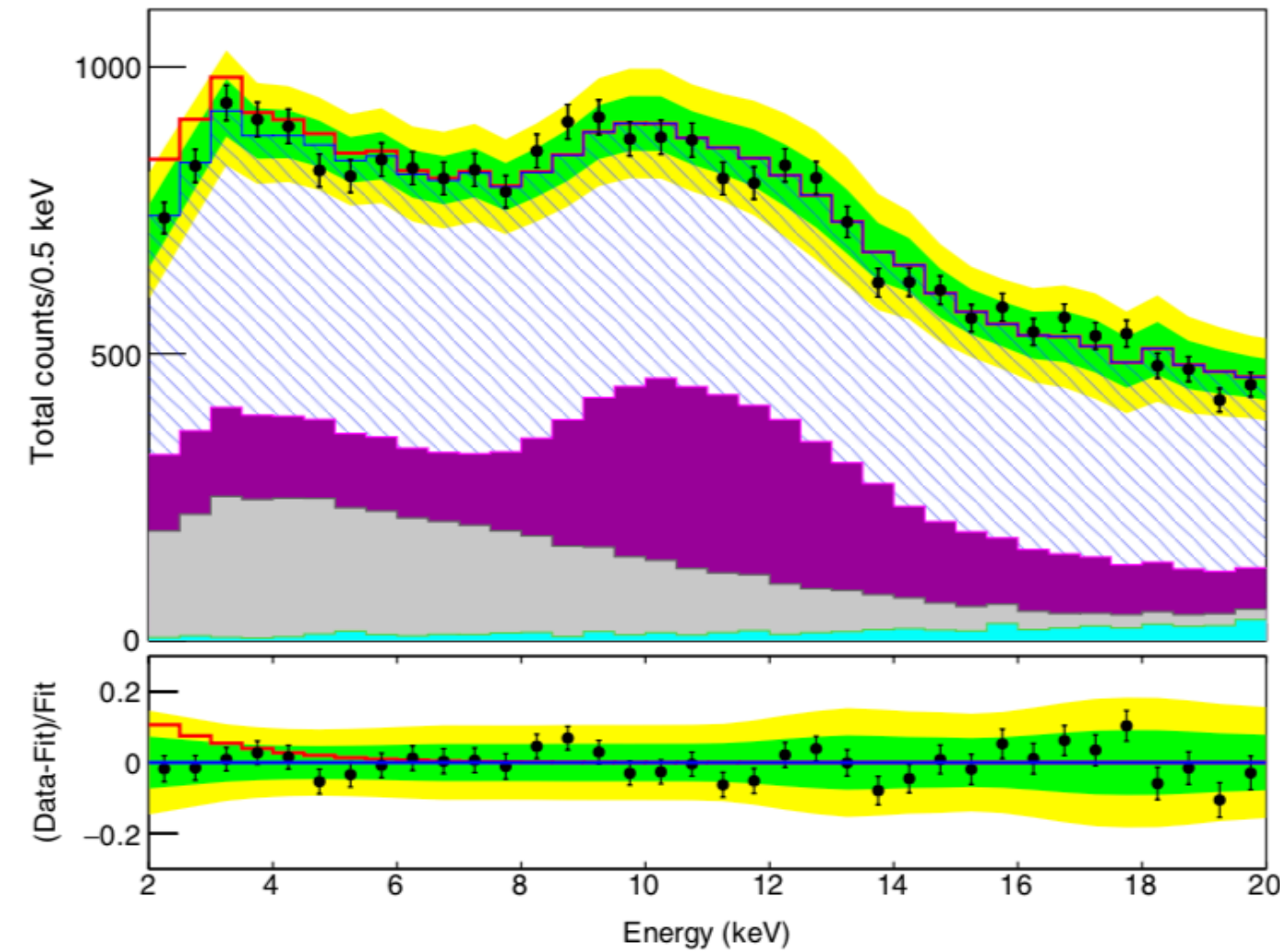

e) Crystal 6

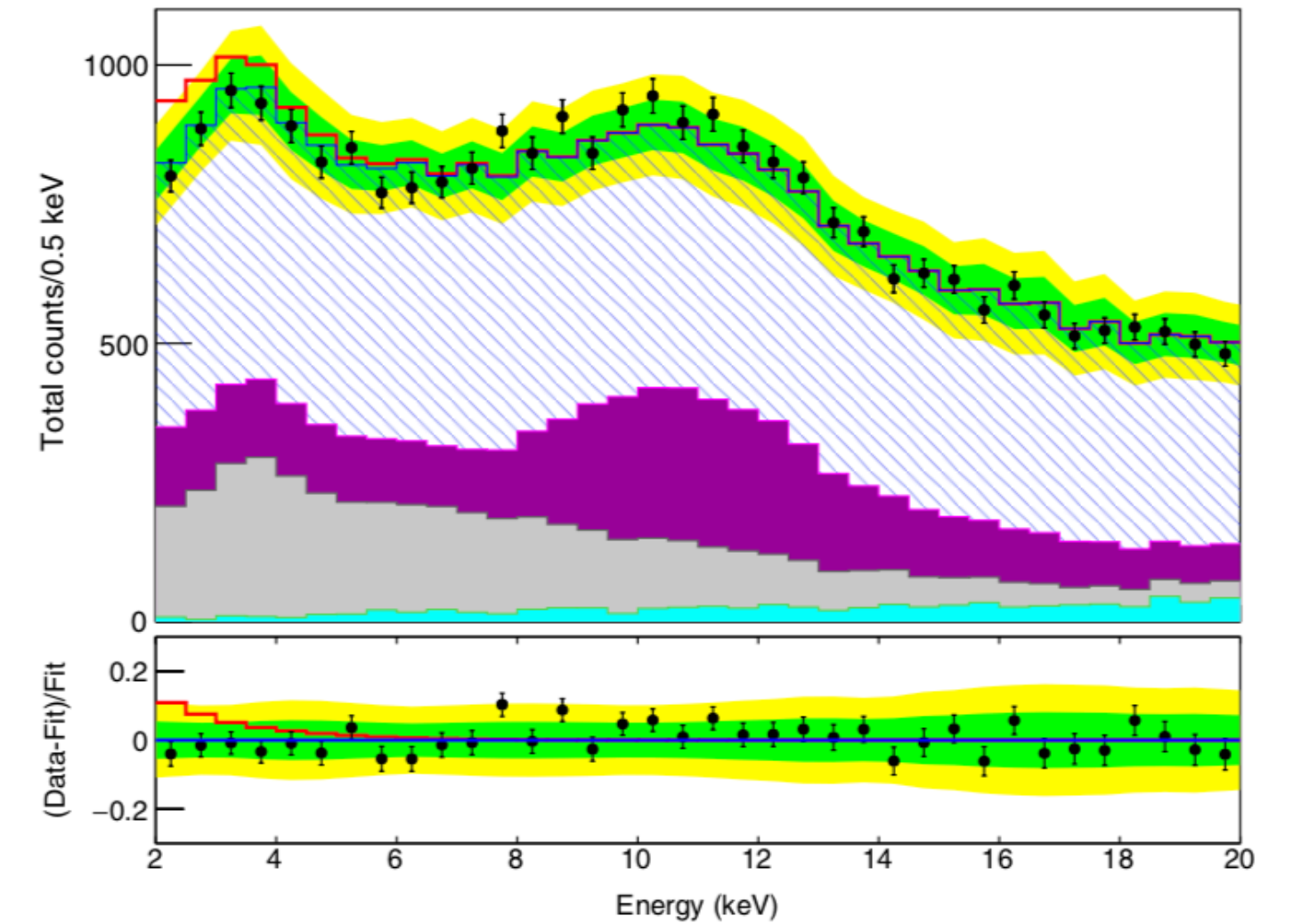

f) Crystal 7

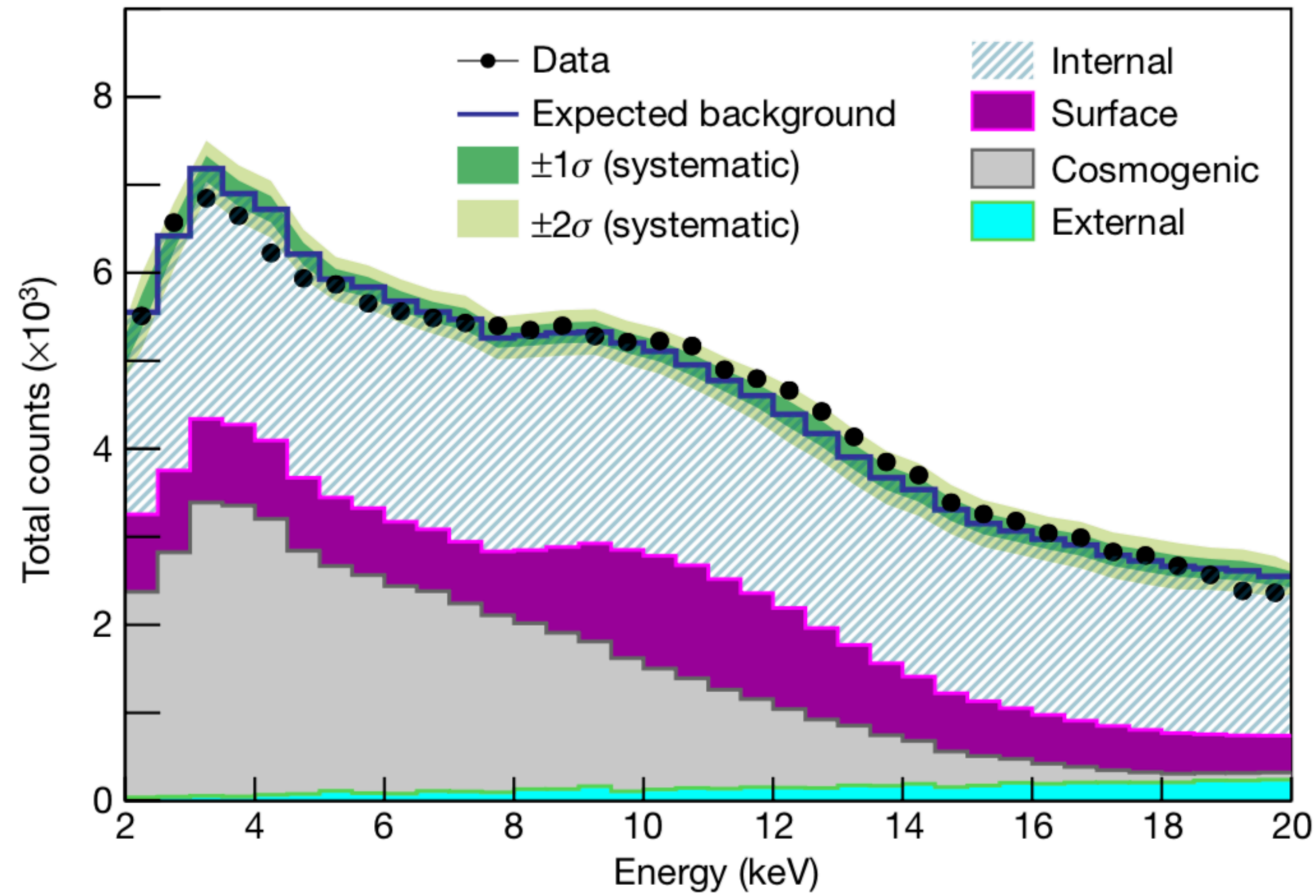

Measured and simulated energy spectra, summed for the six crystals

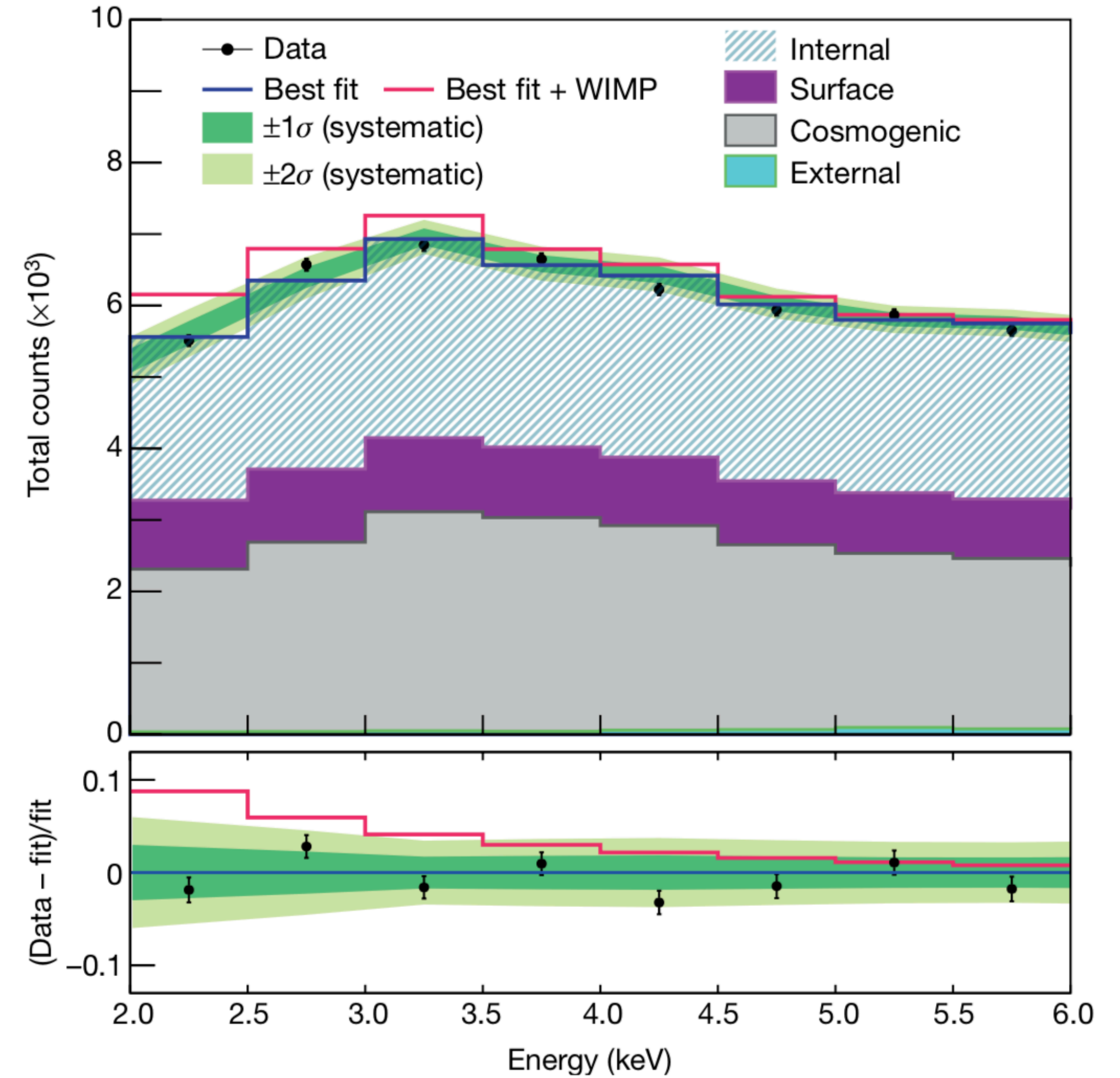

Fit result for a WIMP mass of $10 \text{ GeV } c^{-2}$, summed for the six crystals

Physics analysis: WIMP analysis

Nature **564**, 83-86 (2018)

- Spectrum with known sources of backgrounds
- COSINE-100 excludes DAMA/LIBRA-phase1's signal as spin-independent WIMP with Standard Halo Model in NaI(Tl)
- Consistent with null results from other direct detect experiments with different target medium

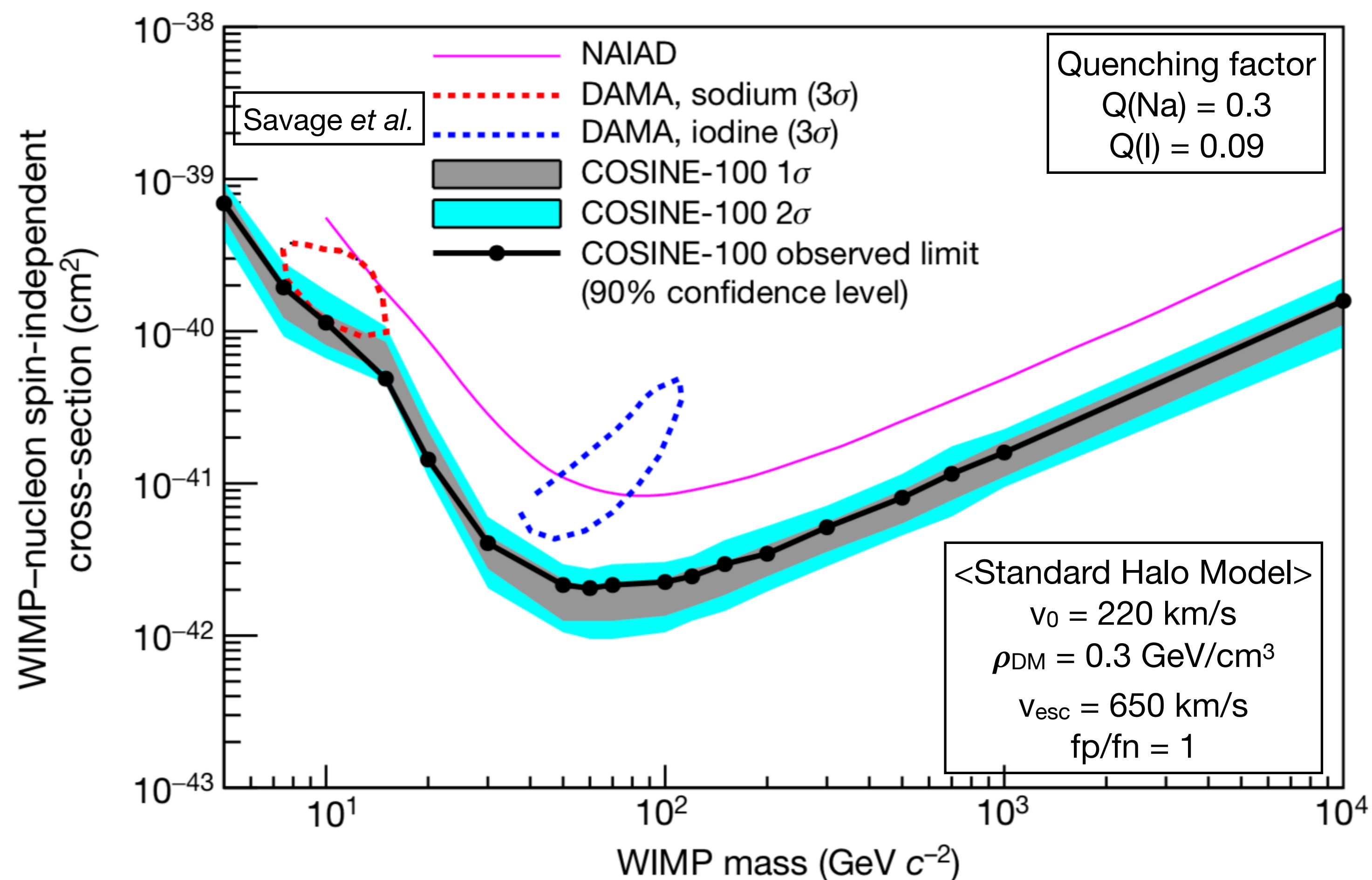

So...is DAMA dead?

- Unfortunately, not yet...
 - With the current spectral decomposition analysis, we can only reject a certain ‘model’ of the dark matter that can be interpreted from DAMA
 - We confirmed that DAMA’s modulation signal cannot be from standard WIMP in SHM with the same target material
 - *“I think this is one more nail in the coffin.”* - Dan Hooper

It is true that the COSINE-100 result only ruled out the simplest version of WIMPS, and for a complete test of DAMA, the annual modulation search is required

So...is DAMA dead? Quotes from DAMA

ScienceNews
MAGAZINE OF THE SOCIETY FOR SCIENCE & THE PUBLIC

SUPPORT SCIENCE NEWS
Help us keep you informed.
Real Science. Real News. SUBSCRIBE

Search Science News...

MENU TOPICS BLOGS EDITOR'S PICKS MAGAZINE

LATEST MOST VIEWED

GROWTH CURVE
Probiotics don't help puking kids, two large trials suggest
BY LAURA SANDERS JANUARY 03, 2019

NEWS
New Horizons shows Ultima Thule looks like a snowman, or maybe BB-8
BY LISA GROSSMAN JANUARY 02, 2019

NEWS
A new implant uses light to control overactive bladders
BY MARIA TEMMING JANUARY 02, 2019

WILD THINGS
Poop provides a link in determining penguin diet from space
BY SARAH ZIELINSKI JANUARY 02, 2019

THE SCIENCE LIFE
This scientist watches meat rot to decipher the Neandertal diet
BY LAUREL HAMERS JANUARY 02, 2019

SOCIETY UPDATE
The Society's Top 10 moments of 2018

NEWS
Known as the 'mother of Hubble,' astronomer Nancy Roman dies at

NEWS PARTICLE PHYSICS

A controversial sighting of dark matter is looking even shakier

The COSINE-100 experiment finds no evidence of the evasive subatomic particles
BY EMILY CONOVER 1:00PM, DECEMBER 5, 2018

DAMA DRAMA The COSINE-100 dark matter detector (pictured) found no signs of the mysterious subatomic particles interacting in sodium iodide crystals, casting doubt on the earlier DAMA experiment.

JAY HYUN JO

Science Home News Journals Topics Careers

2019 AAAS MARTIN AND ROSE WACHTEL CANCER RESEARCH AWARD For young investigators in cancer research Due February 1, 2019 Submit your application » Science Translational Medicine AAAS Log in | My account

SHARE

f 614

t 1

in

The COSINE-100 detector was built to reproduce a controversial claim of the detection of dark matter. JAY HYUN JO

Underground experiment casts doubt on controversial dark matter claim

By Adrian Cho | Dec. 5, 2018, 1:40 PM

“COSINE-100 has no impact on the long-standing results obtained with the DAMA setups” - R. Bernabei

... But Bernabei says the test is too weak to do that. “The modeling of a background is a quite uncertain procedure and at low energy is in general not reliable”

It is true that the COSINE-100 result only ruled out the simplest version of WIMPS, and for a complete test of DAMA, the annual modulation search is required

1.7 yrs, 97.7 kg yrs exposure

- Global fit using cosmogenic and sinusoidal components simultaneously for crystals
- Crystal-1, 5, and 8 excluded in this analysis due to low light yield and excessive PMT noise
- Sideband events decrease exponentially, agrees with known cosmogenic components

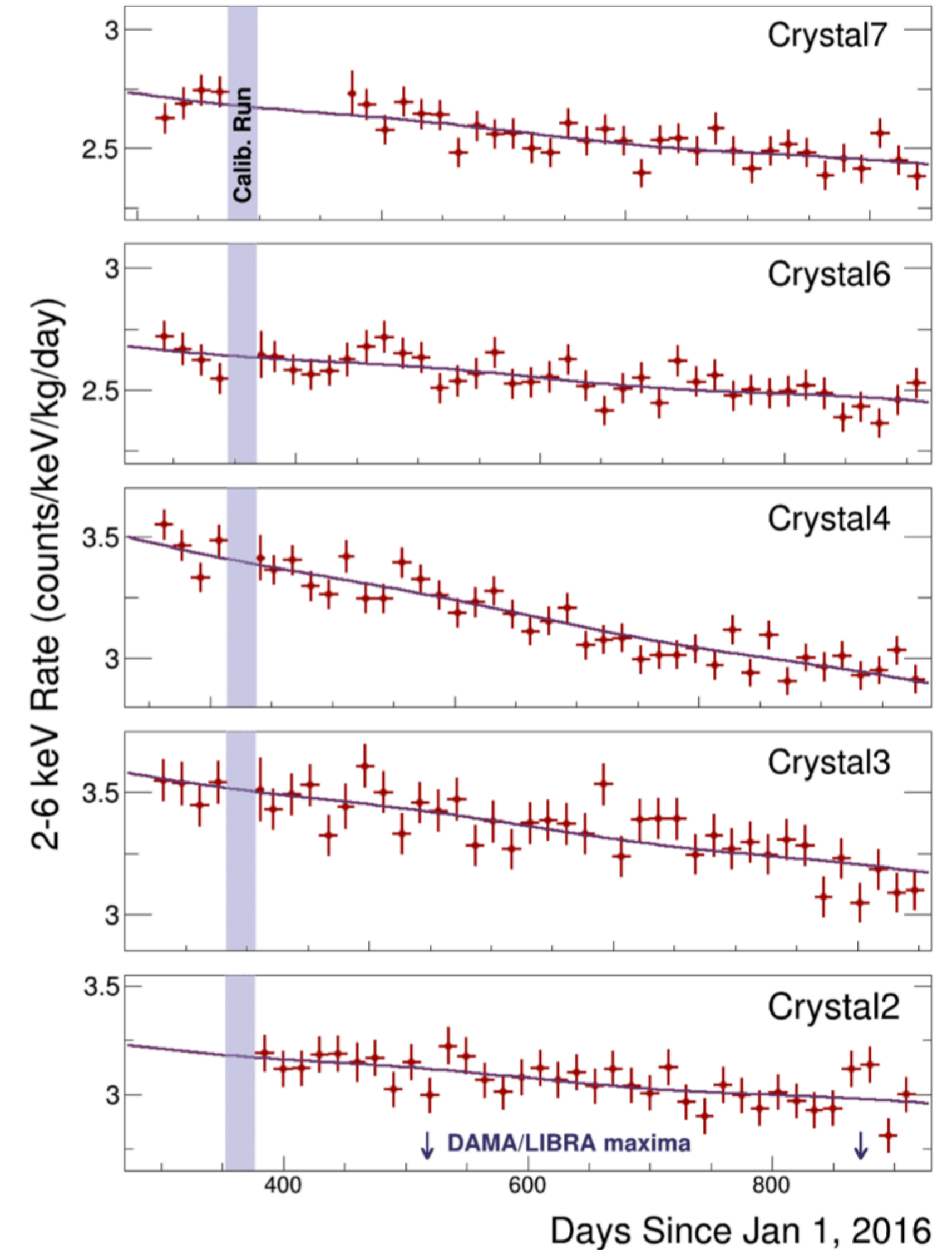
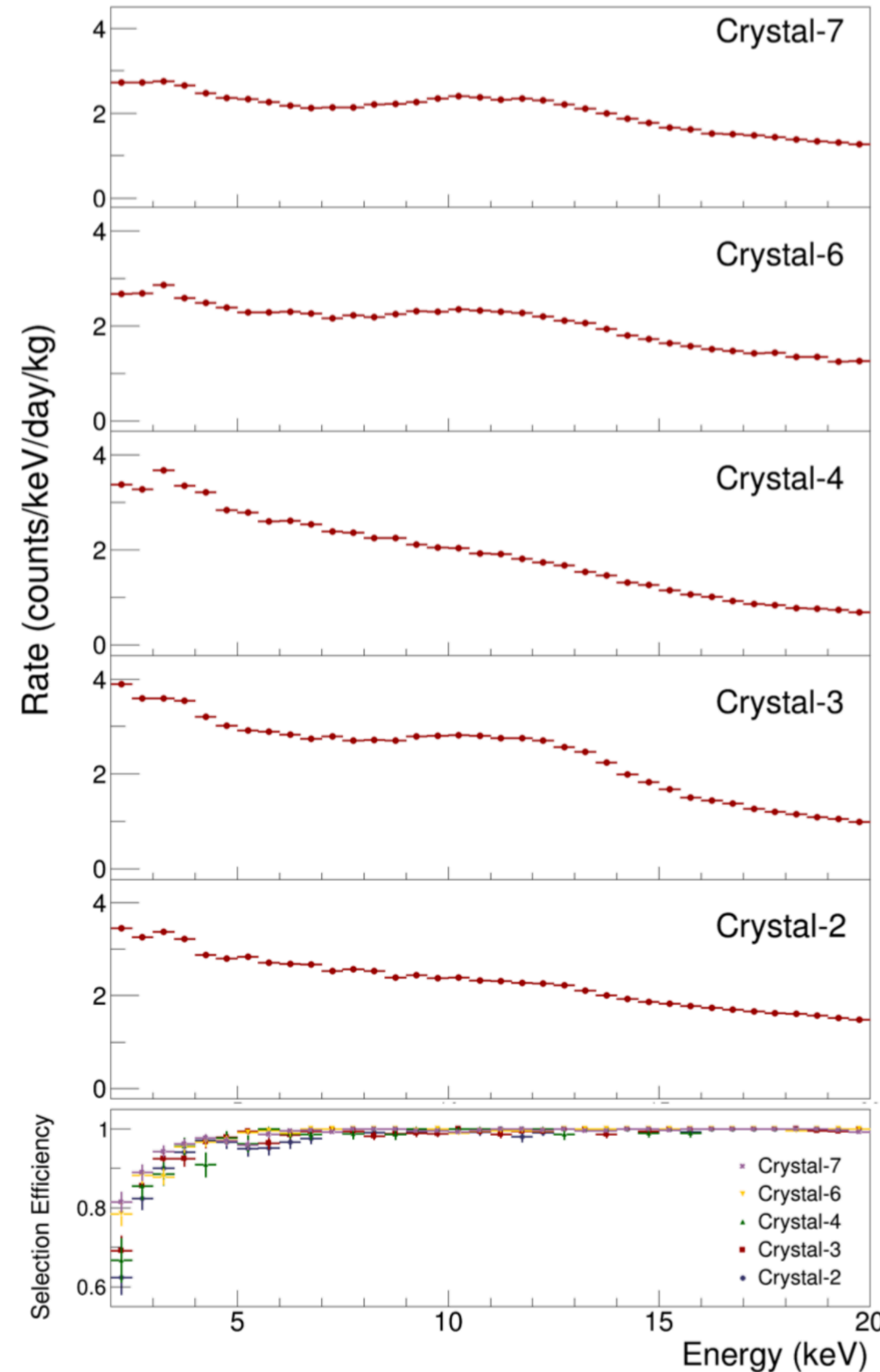

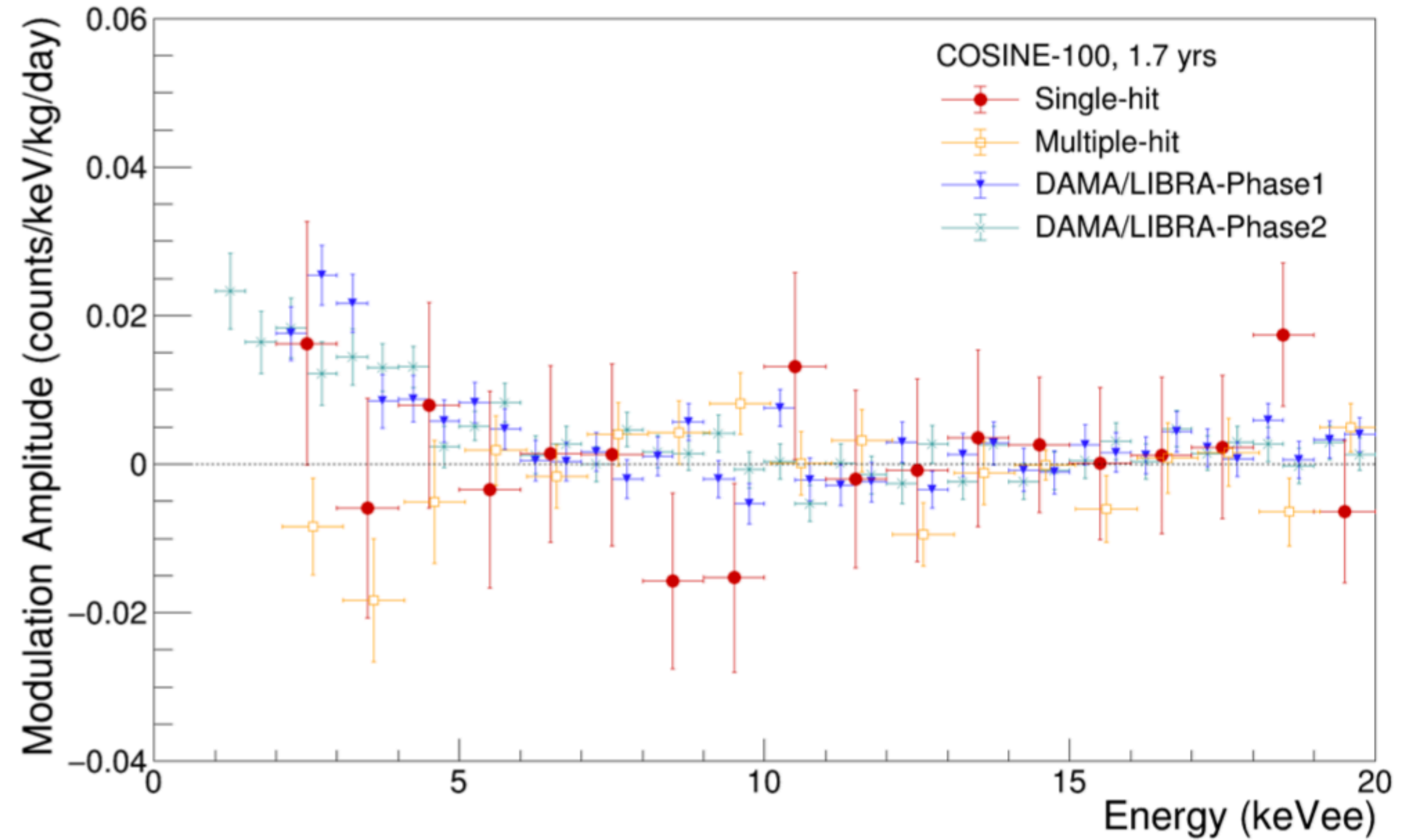
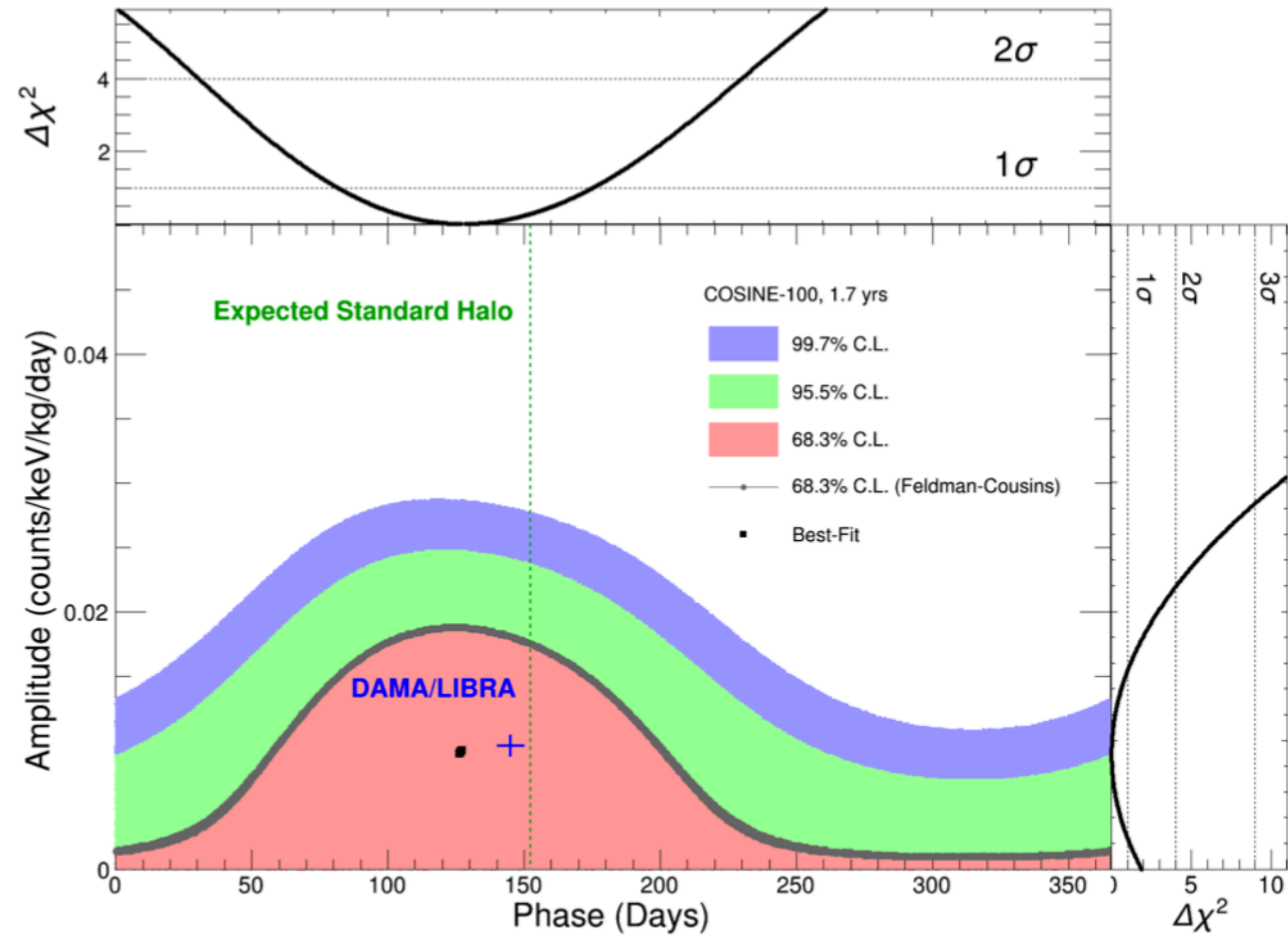

- Best fit amplitude for 2–6 keV
 - 0.0092 ± 0.0067 cpd/kg/keV
 - 127.2 ± 45.9 cpd/kg/keV
- Statistically limited, not yet able to distinguish DAMA/null

Configuration	χ^2	<i>d.o.f.</i>	p-value	Amplitude (counts/keV/kg/day)	Phase (Days)
COSINE-100	175.3	174	0.457	0.0092 ± 0.0067	127.2 ± 45.9
DAMA/LIBRA (Phase1+Phase2)	–	–	–	0.0096 ± 0.0008	145 ± 5
COSINE-100	175.6	175	0.473	0.0083 ± 0.0068	152.5 (fixed)
COSINE-100 (Without LS)	194.7	175	0.143	0.0024 ± 0.0071	152.5 (fixed)
ANAIS-112	48.0	53	0.67	-0.0044 ± 0.0058	152.5 (fixed)
DAMA/LIBRA (Phase1+Phase2)	71.8	101	0.988	0.0095 ± 0.0008	152.5 (fixed)

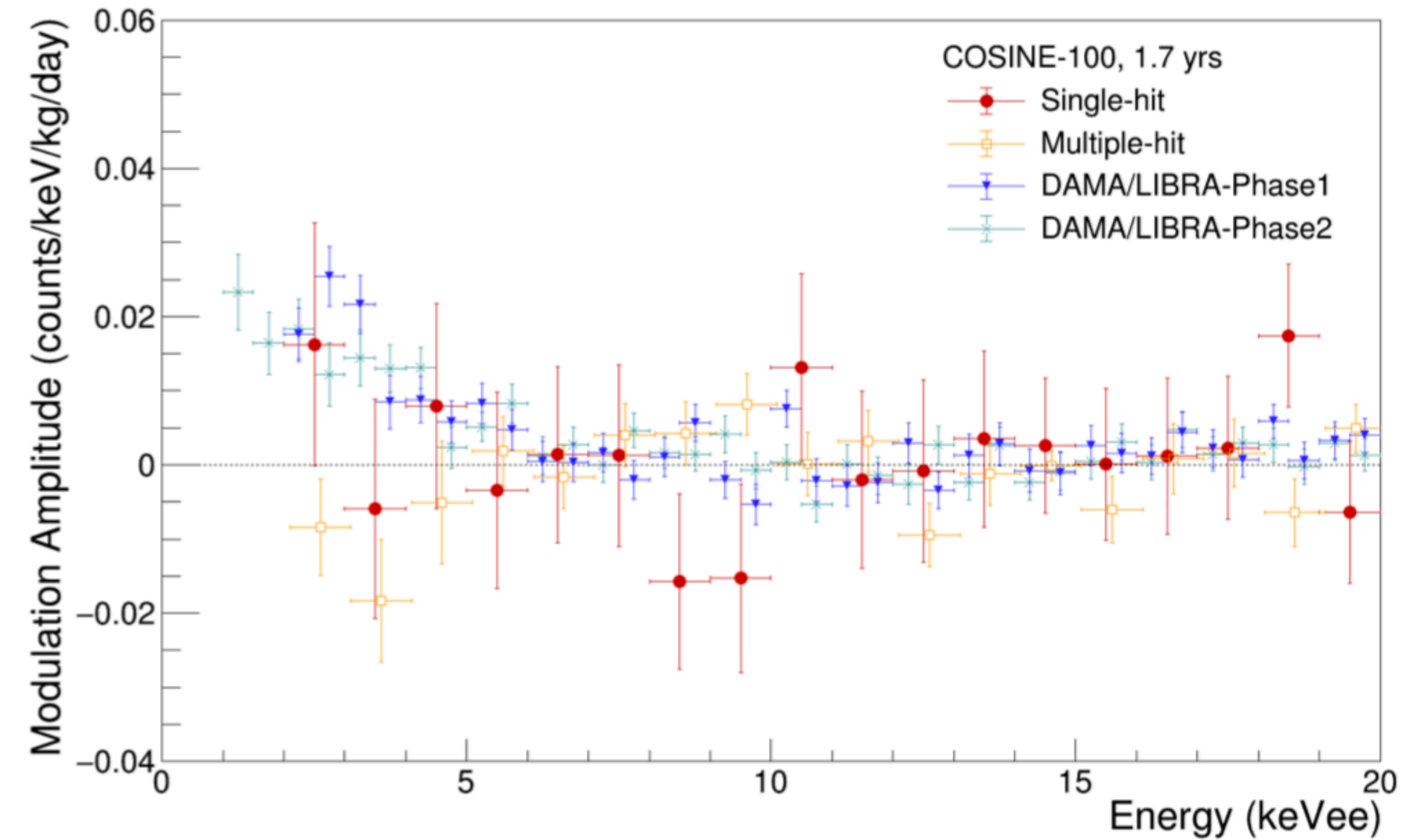
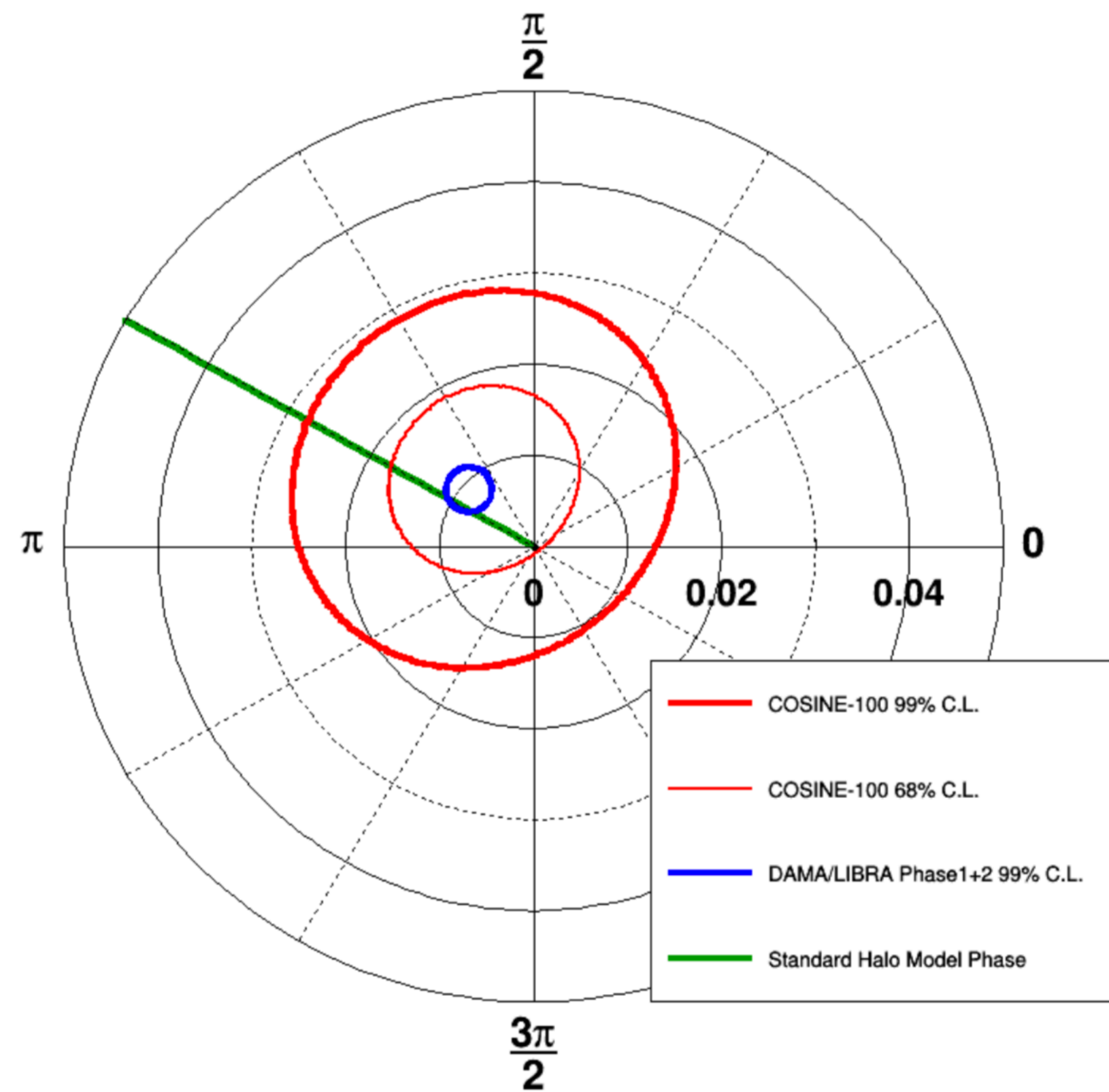

- Best fit amplitude for $2 - 6$ keV
 - 0.0092 ± 0.0067 cpd/kg/keV
 - 127.2 ± 45.9 cpd/kg/keV
- Statistically limited, not yet able to distinguish DAMA/null

Configuration	χ^2	<i>d.o.f.</i>	p-value	Amplitude (counts/keV/kg/day)	Phase (Days)
COSINE-100	175.3	174	0.457	0.0092 ± 0.0067	127.2 ± 45.9
DAMA/LIBRA (Phase1+Phase2)	-	-	-	0.0096 ± 0.0008	145 ± 5
COSINE-100	175.6	175	0.473	0.0083 ± 0.0068	152.5 (fixed)
COSINE-100 (Without LS)	194.7	175	0.143	0.0024 ± 0.0071	152.5 (fixed)
ANAIS-112	48.0	53	0.67	-0.0044 ± 0.0058	152.5 (fixed)
DAMA/LIBRA (Phase1+Phase2)	71.8	101	0.988	0.0095 ± 0.0008	152.5 (fixed)

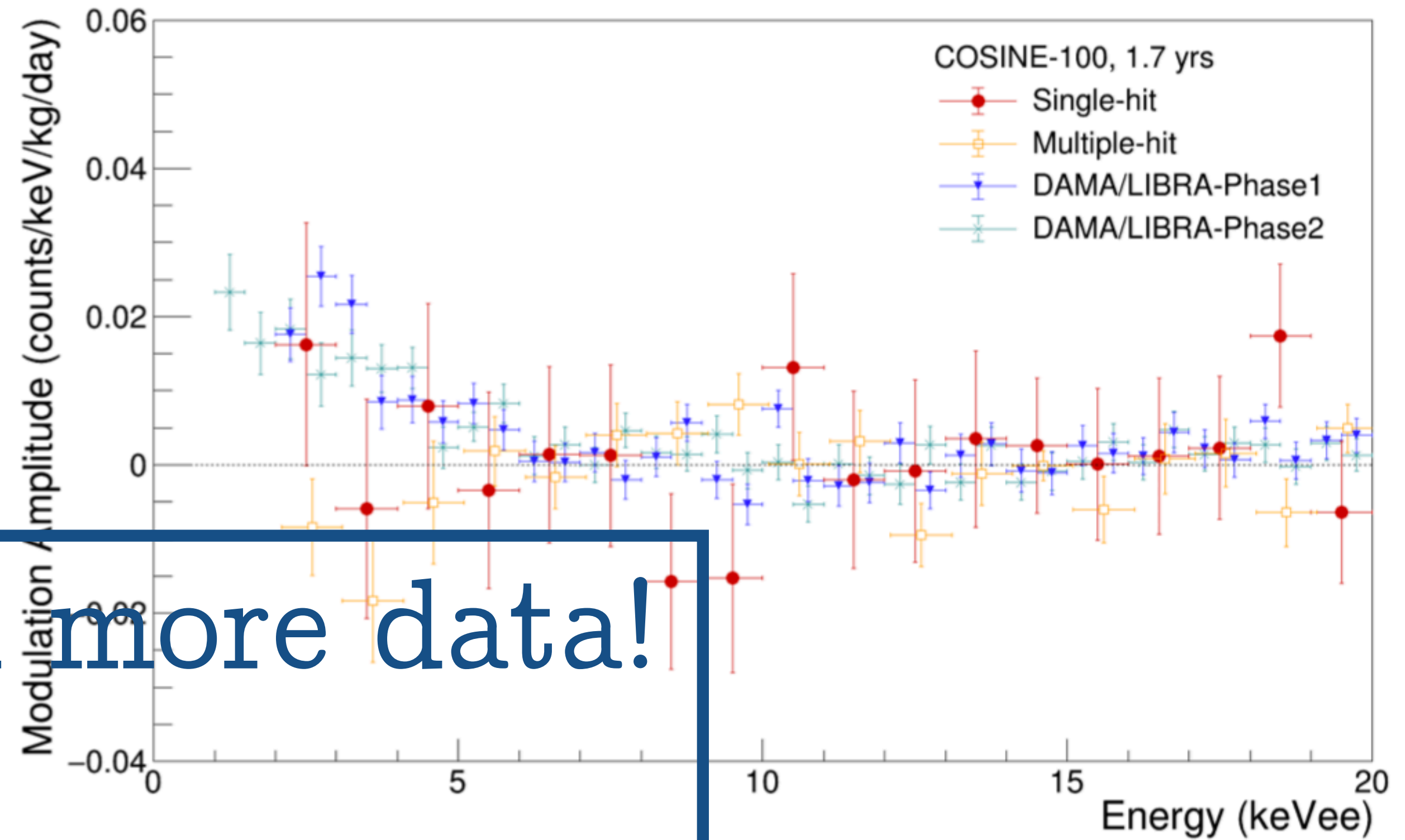
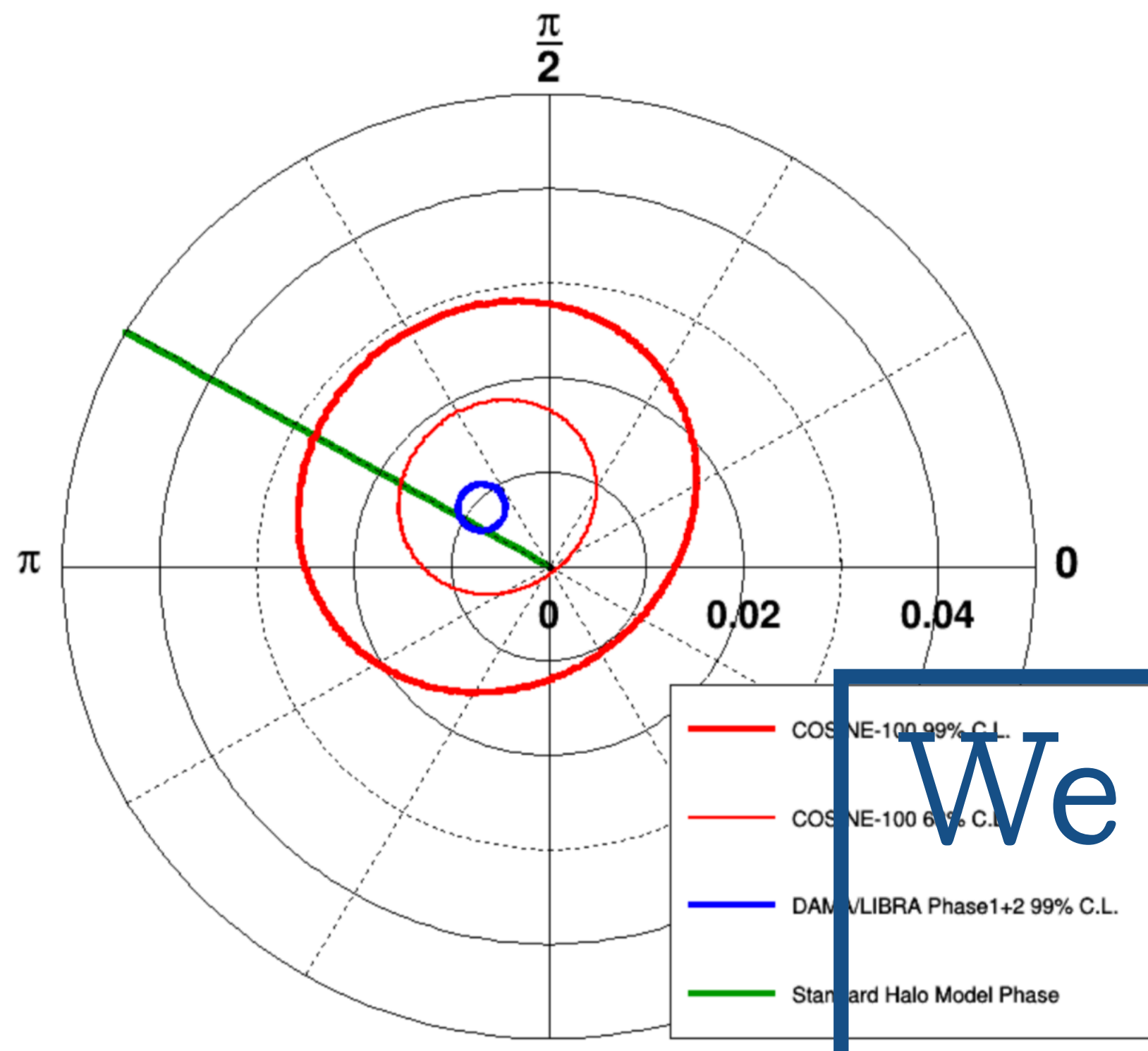

We need more data!
 ...like everyone else...

- Best fit amplitude for 2–6 keV
 - 0.0092 ± 0.0067 cpd/kg/keV
 - 127.2 ± 45.9 cpd/kg/keV

- Statistically limited, not yet able to distinguish DAMA/null

Configuration	χ^2	d.o.f.	p-value	Amplitude (counts/keV/kg/day)	Phase (Days)
COSINE-100	175.3	174	0.457	0.0092 ± 0.0067	127.2 ± 45.9
DAMA/LIBRA (Phase1+Phase2)	–	–	–	0.0096 ± 0.0008	145 ± 5
COSINE-100	175.6	175	0.473	0.0083 ± 0.0068	152.5 (fixed)
COSINE-100 (Without LS)	194.7	175	0.143	0.0024 ± 0.0071	152.5 (fixed)
ANAIS-112	48.0	53	0.67	-0.0044 ± 0.0058	152.5 (fixed)
DAMA/LIBRA (Phase1+Phase2)	71.8	101	0.988	0.0095 ± 0.0008	152.5 (fixed)



ANAIS-112 annual modulation analysis

[ArXiv:1903.03973](https://arxiv.org/abs/1903.03973)

Exposure: 157.55 kg×y

$$R(t) = R_0 + R_1 e^{-t/\tau} + S_m \cos[\omega(t + \phi)]$$

[2-6] keV $\rightarrow S_m = -0.0044 \pm 0.0058$ cpd/kg/keV
 [1-6] keV $\rightarrow S_m = -0.0015 \pm 0.0063$ cpd/kg/keV

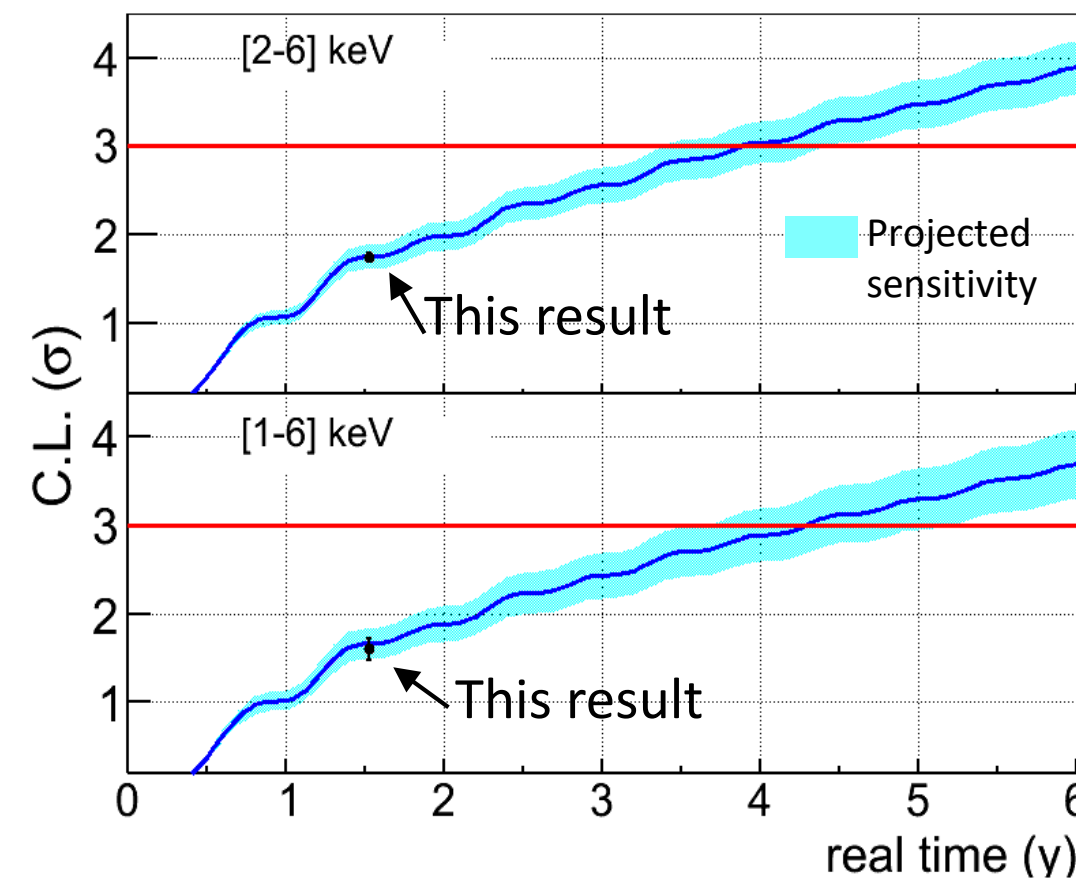
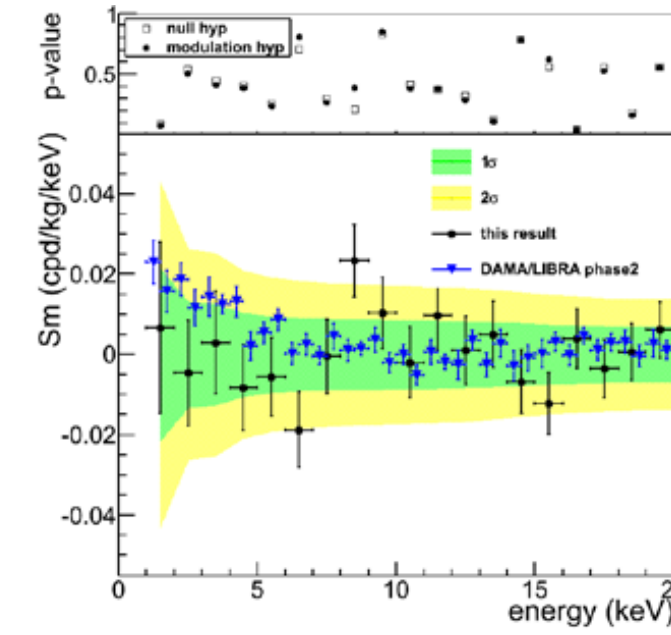
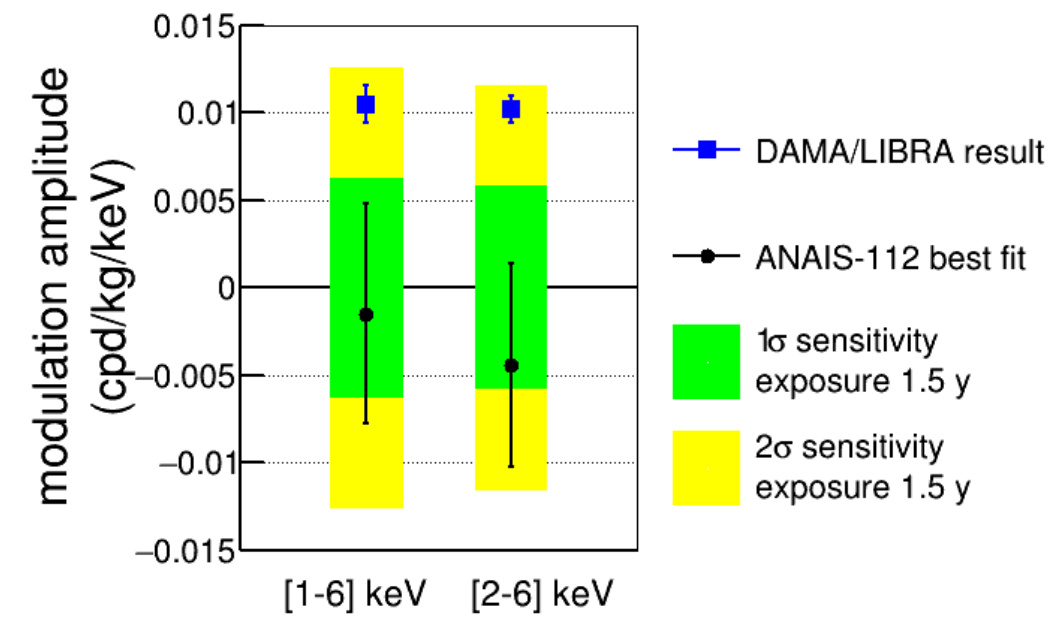
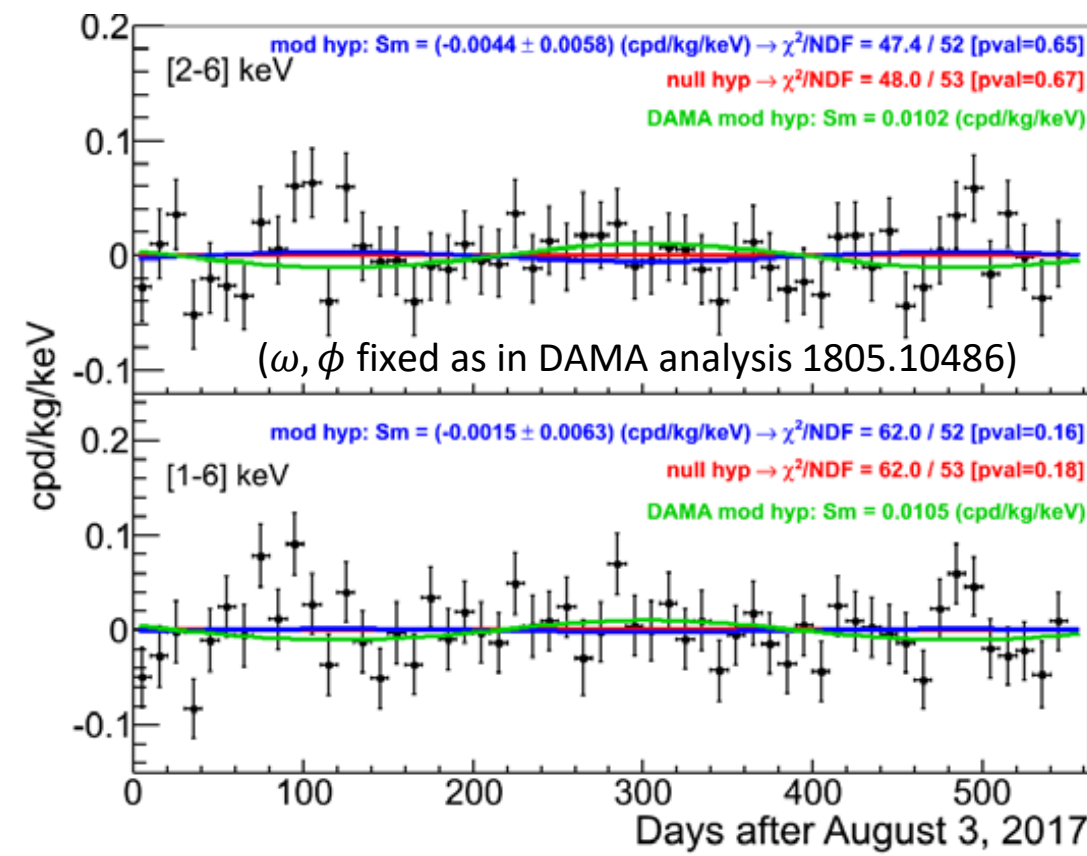

The result for 1.5 years confirms the estimated sensitivity for our background and exposure

Reaching 3σ sensitivity to DAMA/LIBRA result is possible in 2.5 - 3.5 more years of data-taking

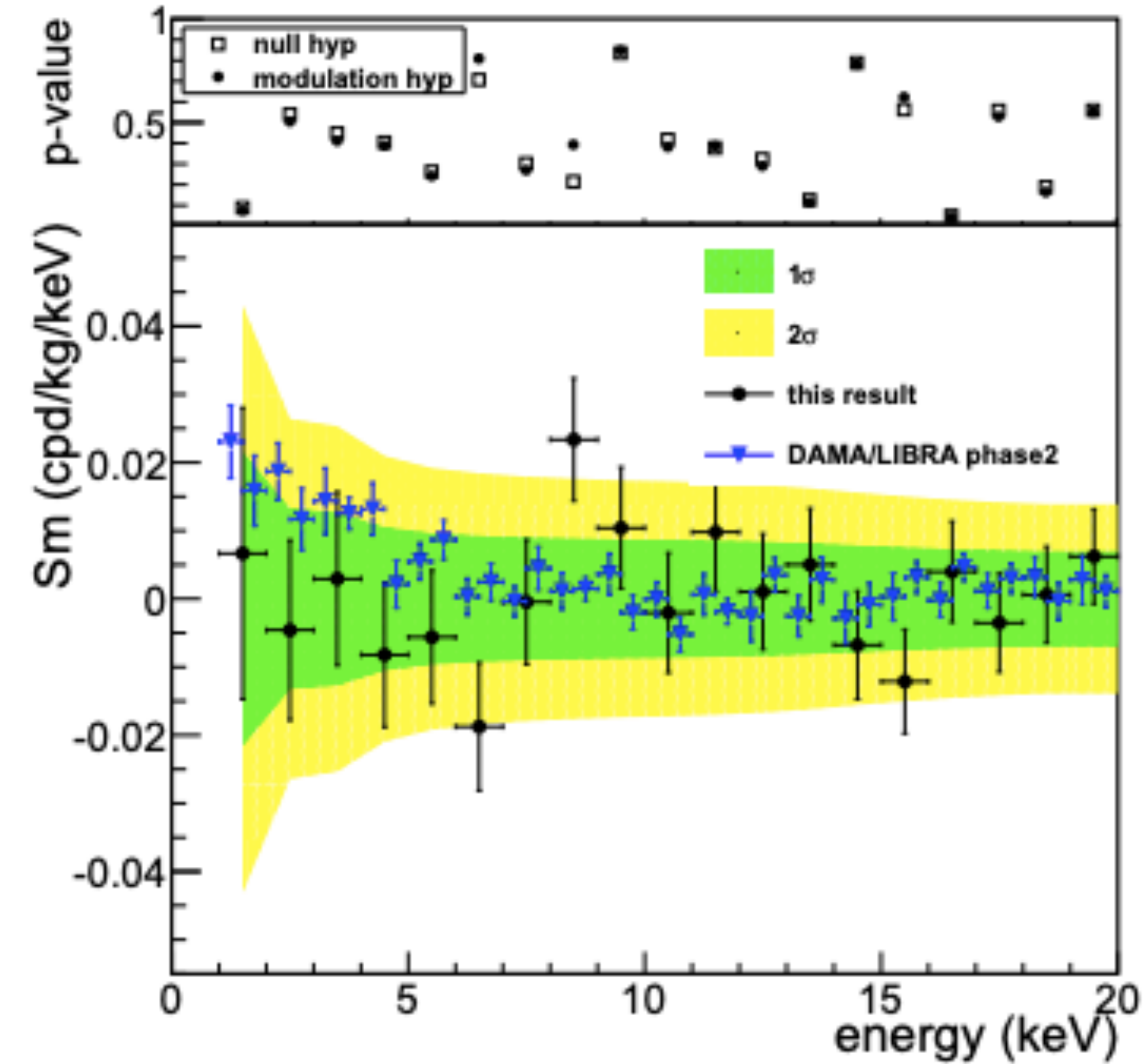

Other physics analyses

- From the background understanding, other interesting searches are actively on-going
- PSD analysis: looking at different decay time between electron/nuclear recoil within NaI(Tl) crystal
- Bosonic Super-WIMP, Solar axion, inelastic Boosted Dark Matter searches, ...

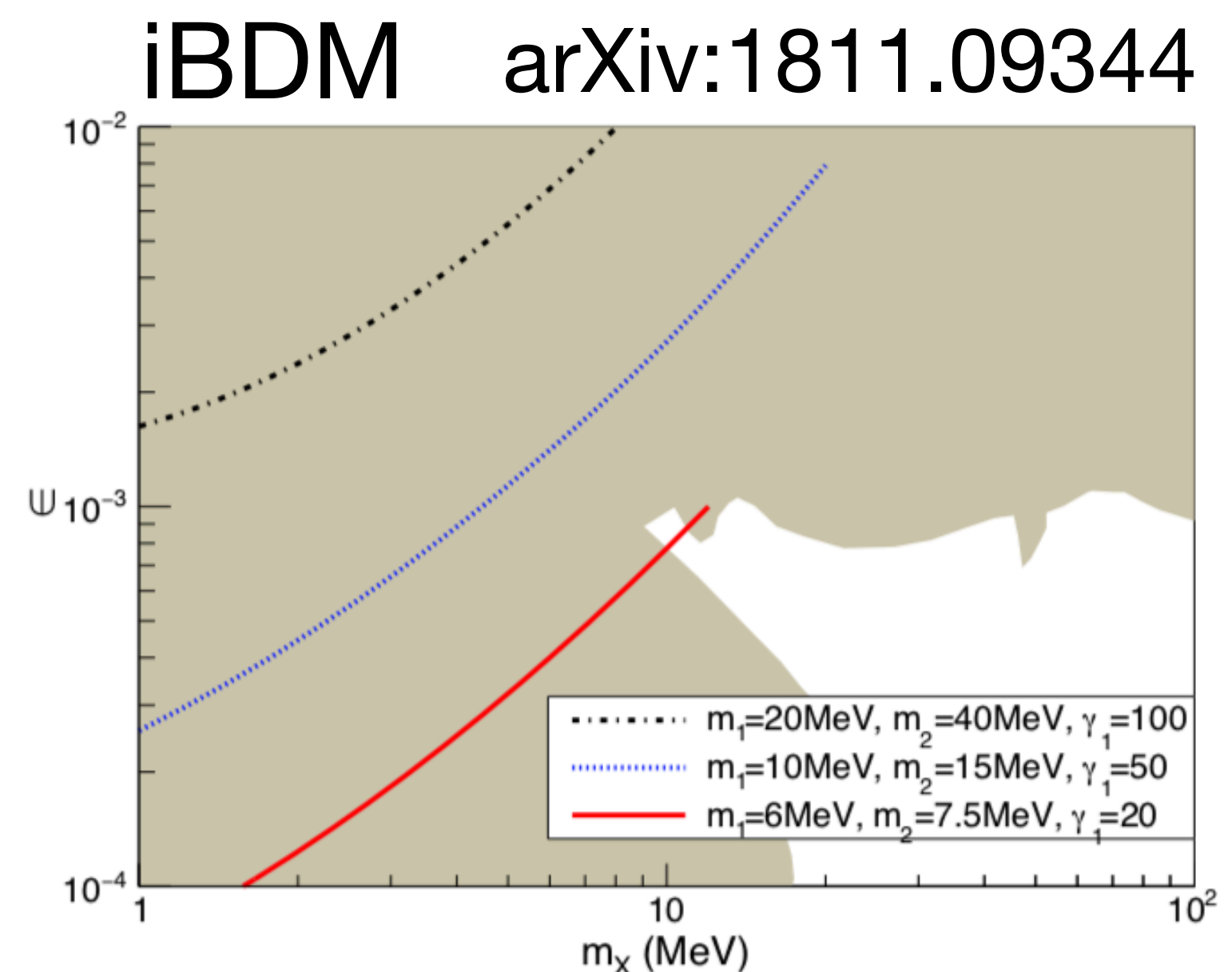
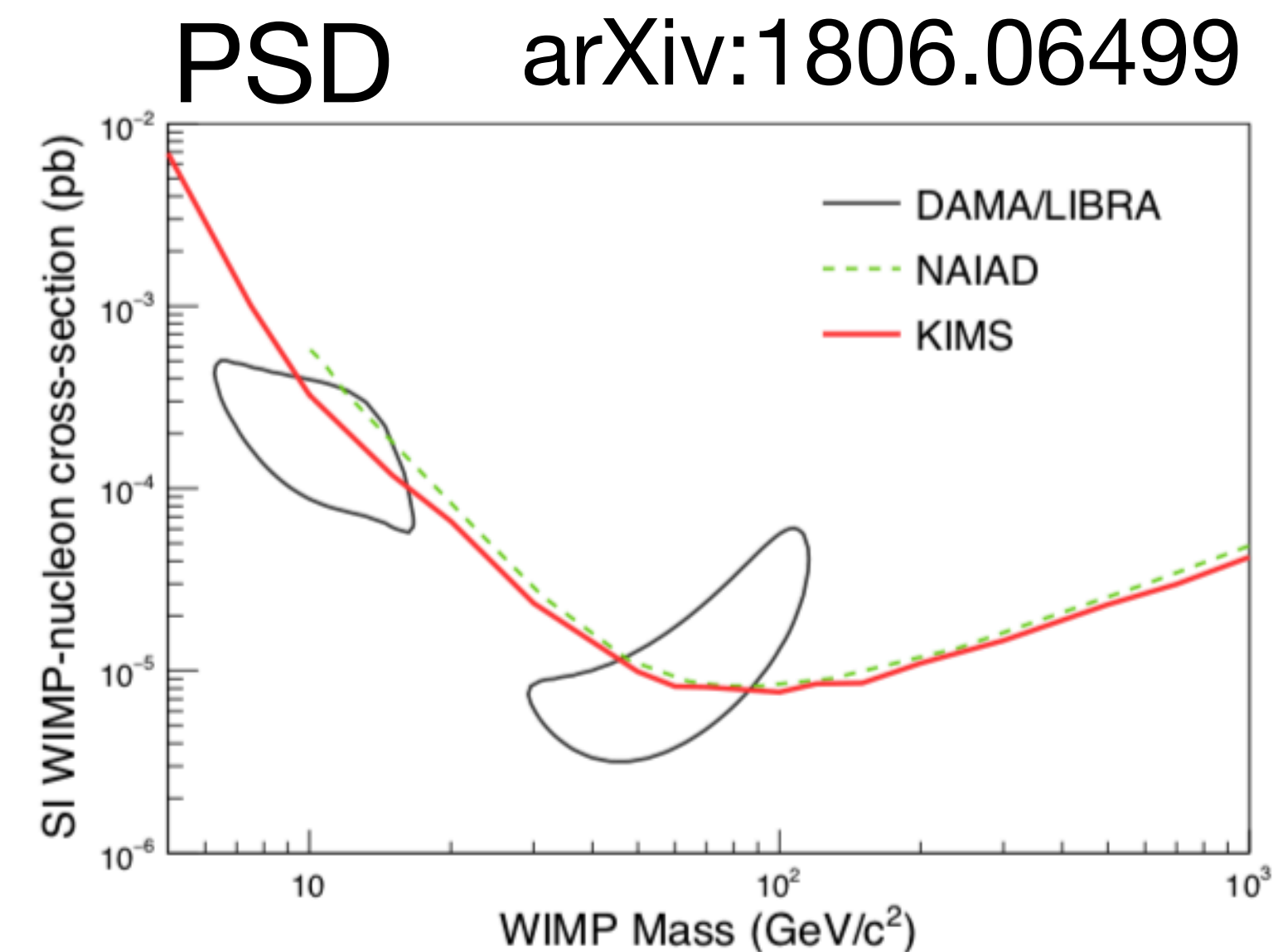
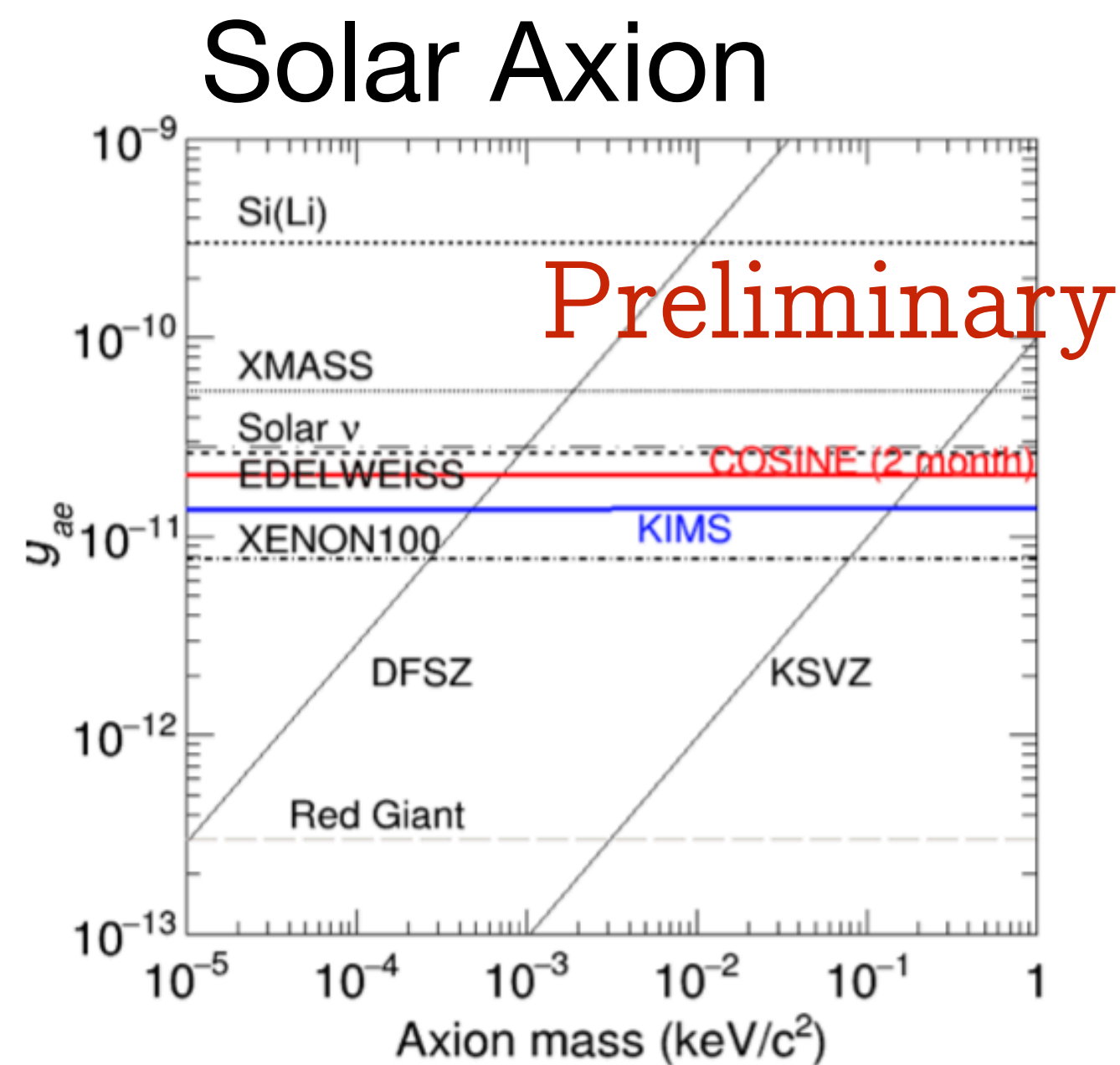

What next?

What next?

- Need to directly test DAMA with the annual modulation analysis
 - With the current background levels of COSINE-100 crystals, it takes **~3 years more exposure**
 - ANAIS has been running with 112 kg of NaI(Tl) crystals from the same manufacturer as COSINE-100, agreed to **combine the result** with COSINE soon
- The most critical factor for the sensitivity is the **crystal background level**, which is currently 2-4 times higher than DAMA's
 - In-house crystal growing is on going at IBS, Korea
 - Involves rigorous studies of NaI powder purification, growth optimization, and crystal encapsulation
 - Initial result promising: planning for upgrade (COSINE-200) with these lower background crystals (~1 DRU)

COSINE-100, 5 years, NULL case

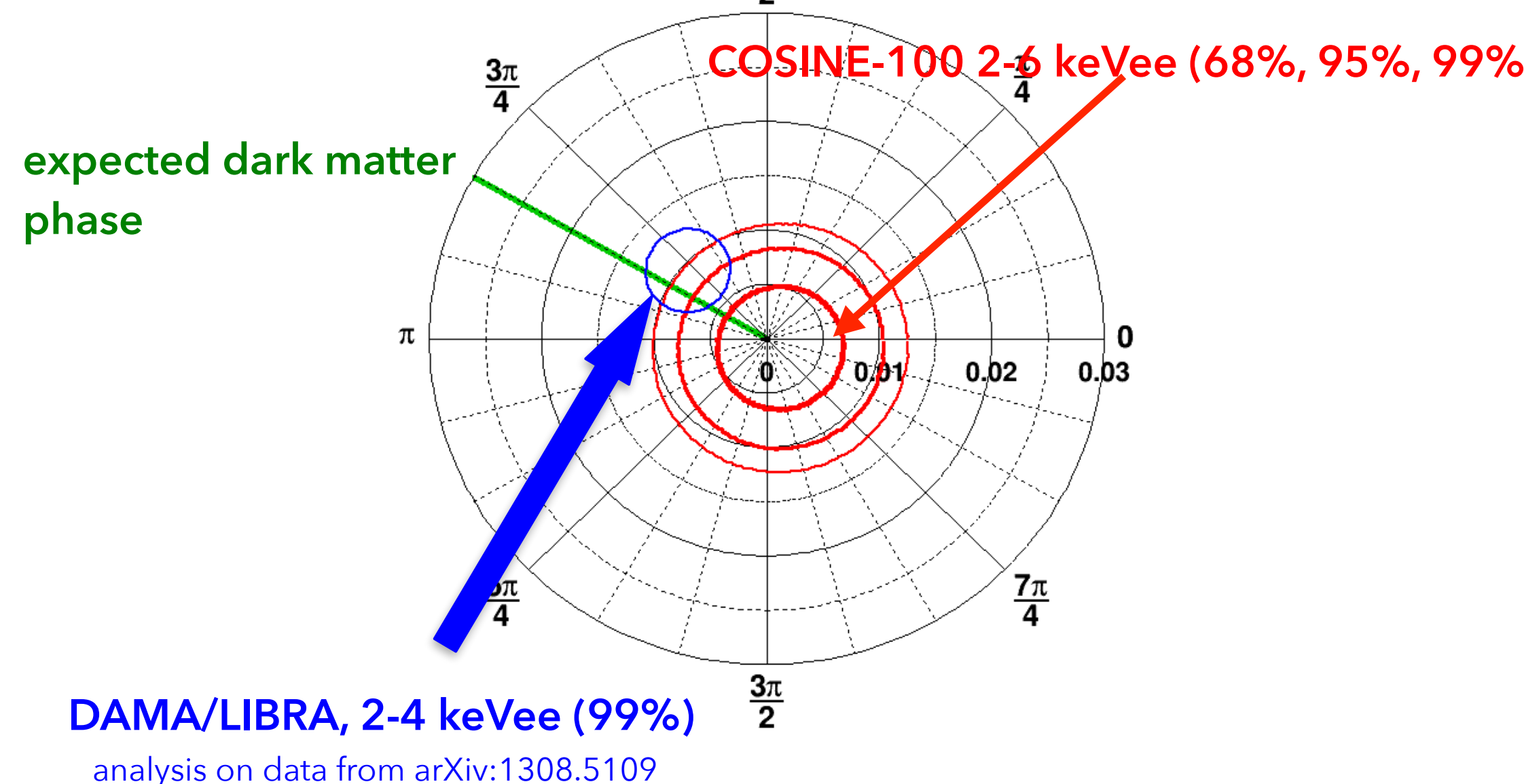

COSINE-200 @ Y2L COSINE-200, 5 years, NULL case

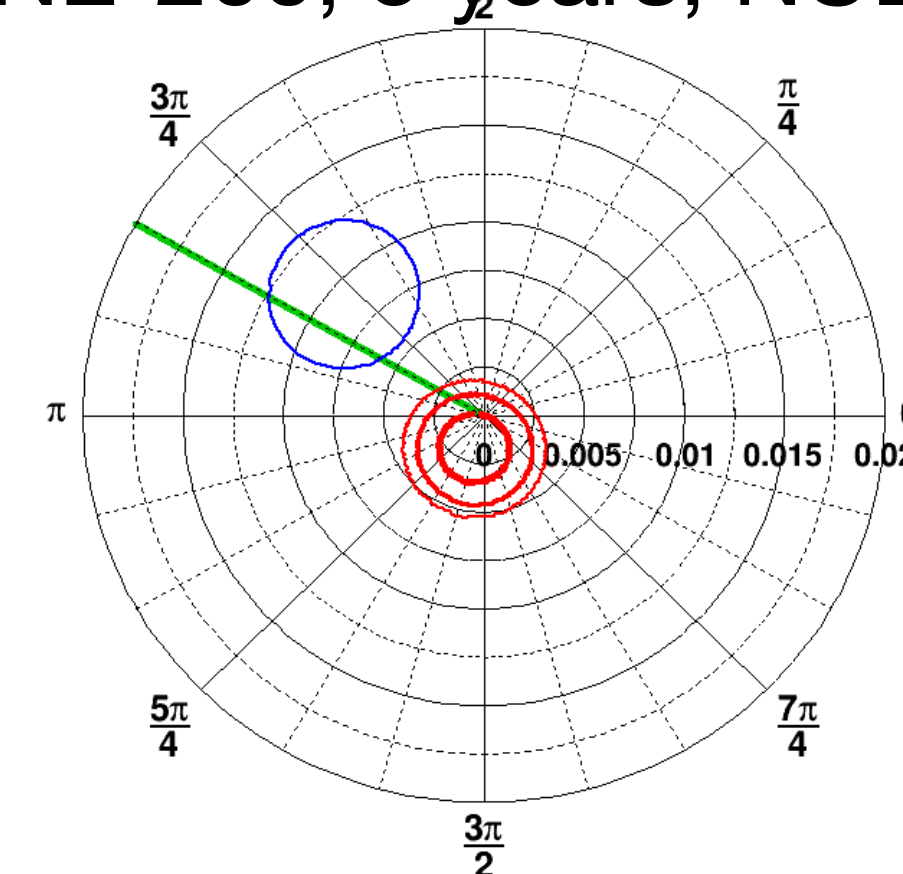
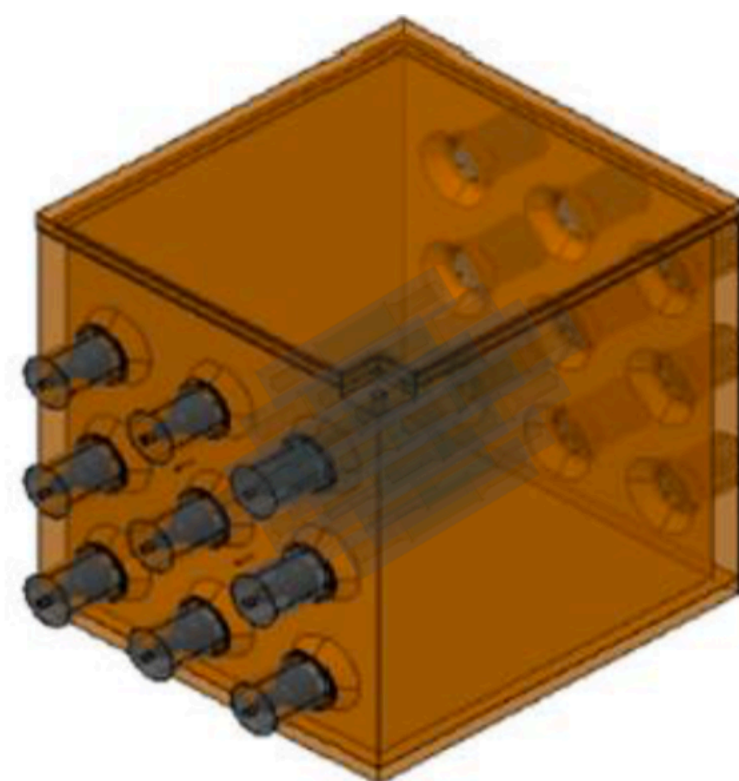

What next? (Crystal growing R&D)

- Needs to grow our own crystal with low(er) background and better understanding of the crystal
- Powder purification system and crystal growers are available at IBS facility
- Went through many trials and errors, found ways to reduce background contamination in powder & improve growth condition of NaI(Tl) crystals
- Current measurements show great improvements!

~ 100 kg NaI crystal (ingot) grower

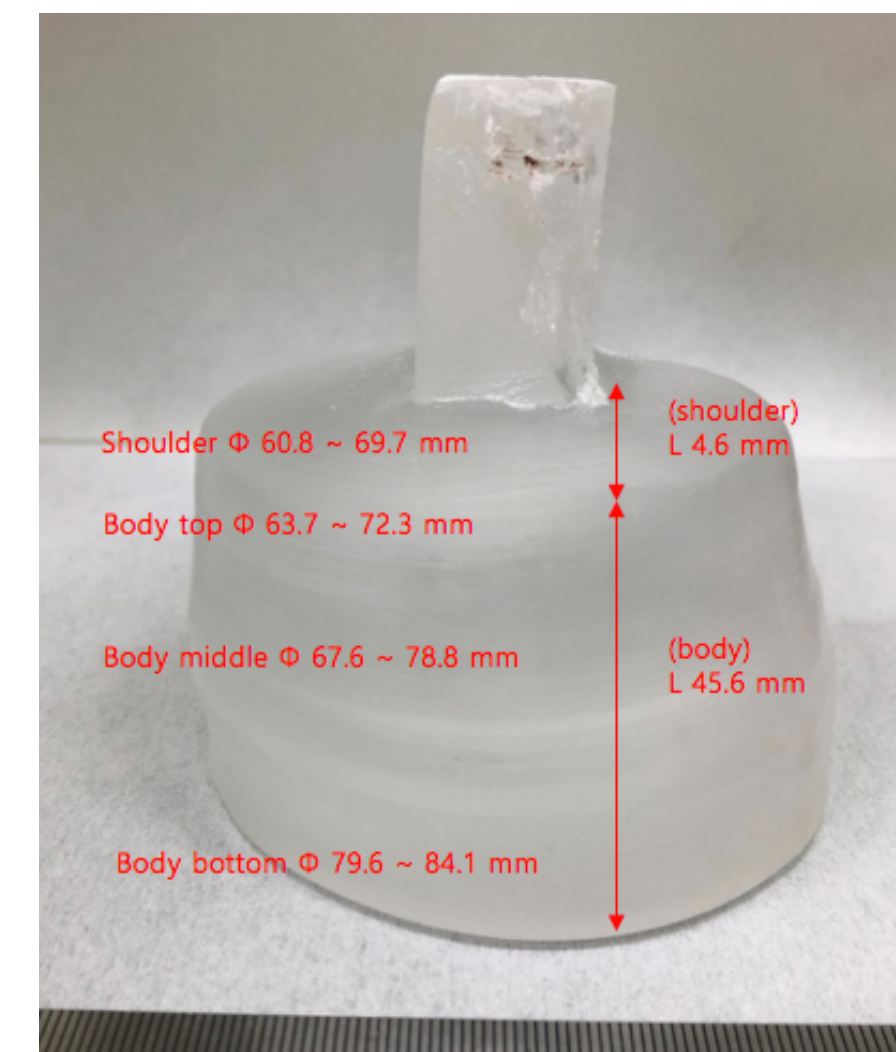

Piping & Instrument Diagram

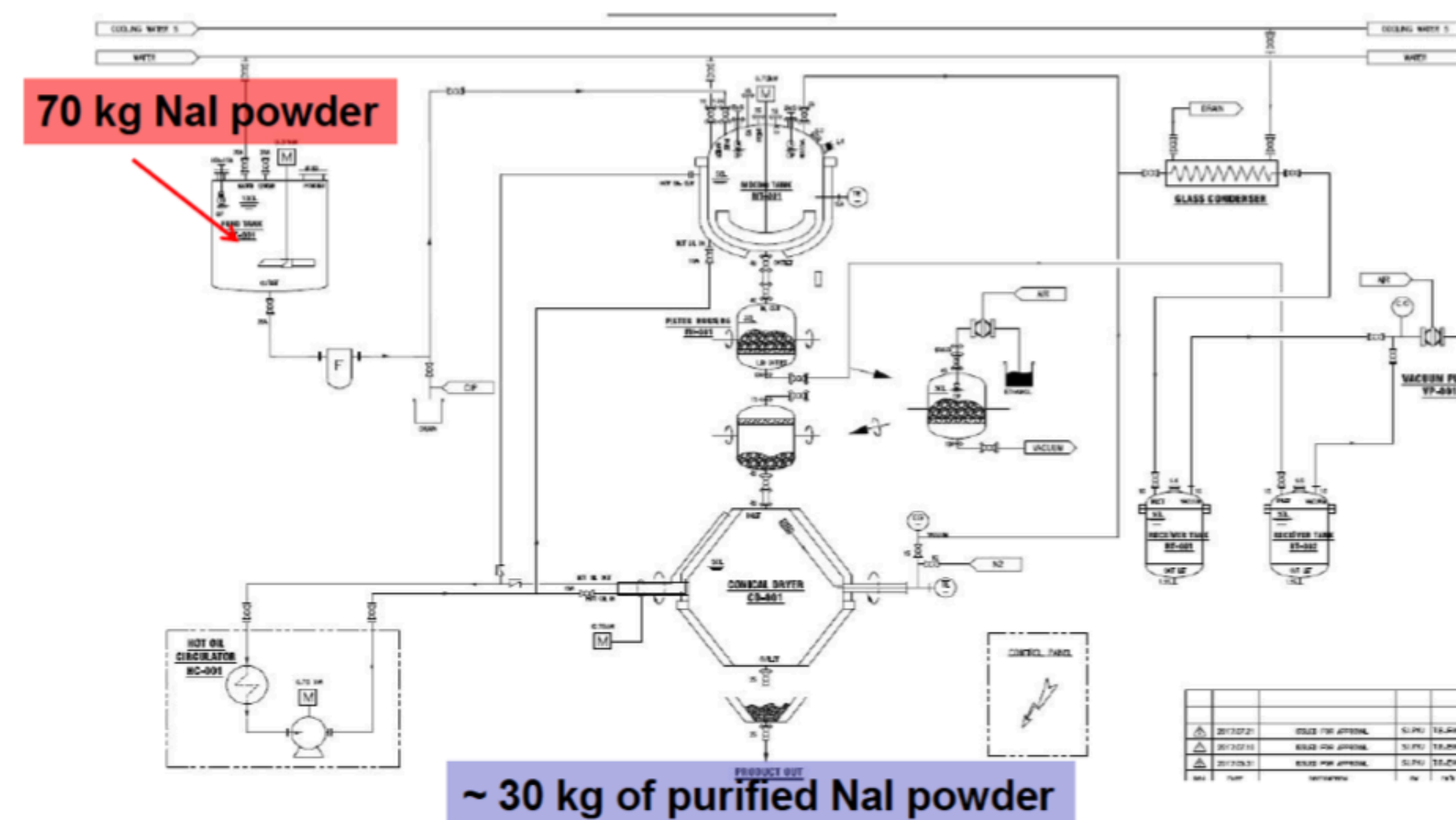

What next?

- **What if we do not see the modulation signal?**
 - We can refute DAMA's claim for dark matter discovery
 - DAMA's signal may be coming from the local effect (LNGS, shielding structure, etc.)

- **What if we do see the modulation signal?**
 - We need to understand the signal
 - The most straightforward idea is to repeat the same experiment in Southern Hemisphere (DM-Ice17, SABRE)
 - COSINE-200 in South Pole under consideration: IceCube upgrade is planned on 2022-2023

COSINE-200 @ South Pole Close-Packed Detector Array

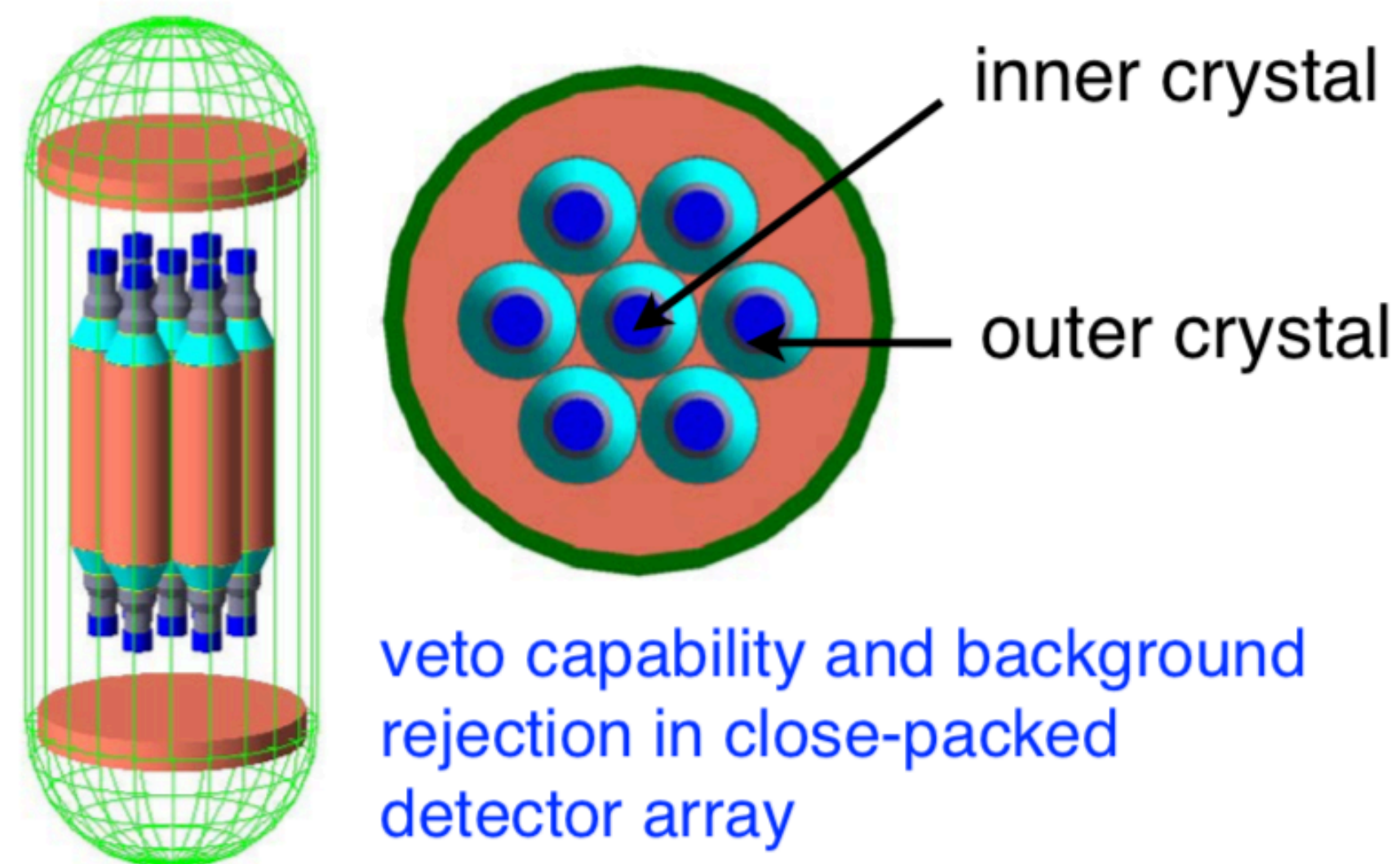

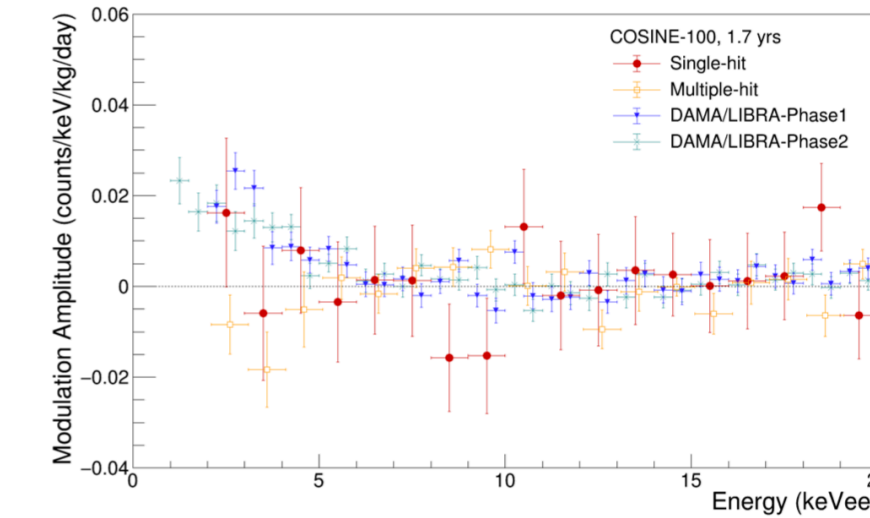
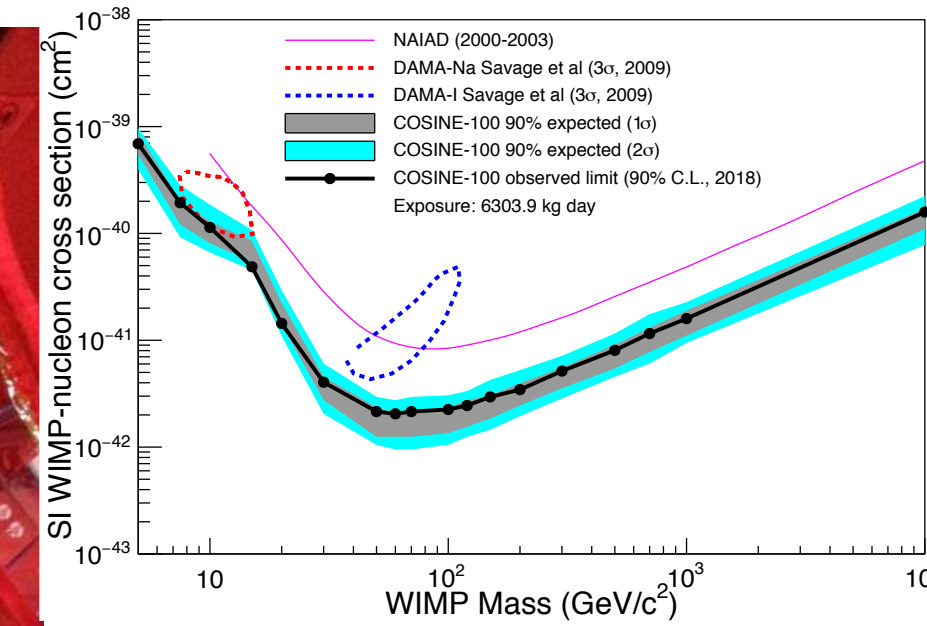
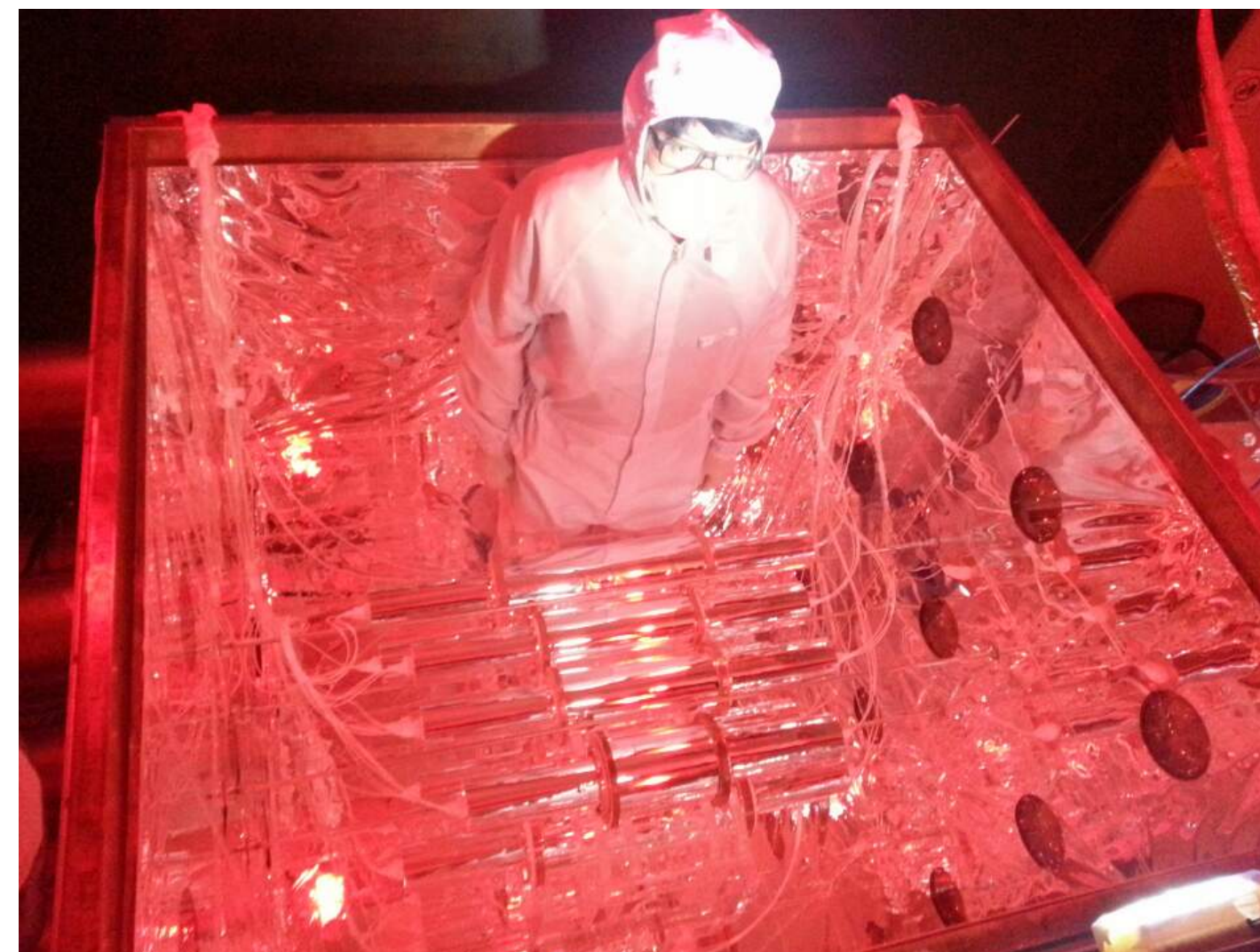

- COSINE-100: Goal is to test DAMA's claim for dark matter observation with the same target material
- COSINE-100 confirms that DAMA's modulation signal cannot be from standard WIMP & SHM with NaI(Tl)
- First modulation analysis with 1.7 years exposure shows consistent result with null hypothesis and DAMA signal, but statistics limited
- Upgrade plans for next phase of COSINE-100 developing: Crystal growing, lowering energy threshold, ANAIS-COSINE data combining, ...
- Stay tuned for more exciting results to come!