

# Experience with field emission at DESY / European XFEL

Denis Kostin, MSL/DESY, 28.01.2025

# General facts about the accelerator

- Year built/commissioned: 2017
- Cryomodule string layout: 8 TESLA type cavities CM, 2K
- Particle free installation practices/protocols applied: yes
- Nominal operating gradient: 23.6 MV/m (max. spec.)
- Administrative/operational radiation limits: 500 $\mu$ Sv/h neutrons
- Accelerated particle species and beam parameters: electrons
  - energy: 6 – 17.5 GeV
  - bunch pulse rep.rate: up to 4.5MHz
  - bunch charge: 100 – 500 pC, project max. 1 nC
  - electron bunch length after compression (FWHM): 20 – 90 fs
  - max. beam power: ~100 kW
  - max. bunches per second: 27000

# General accelerator layout:

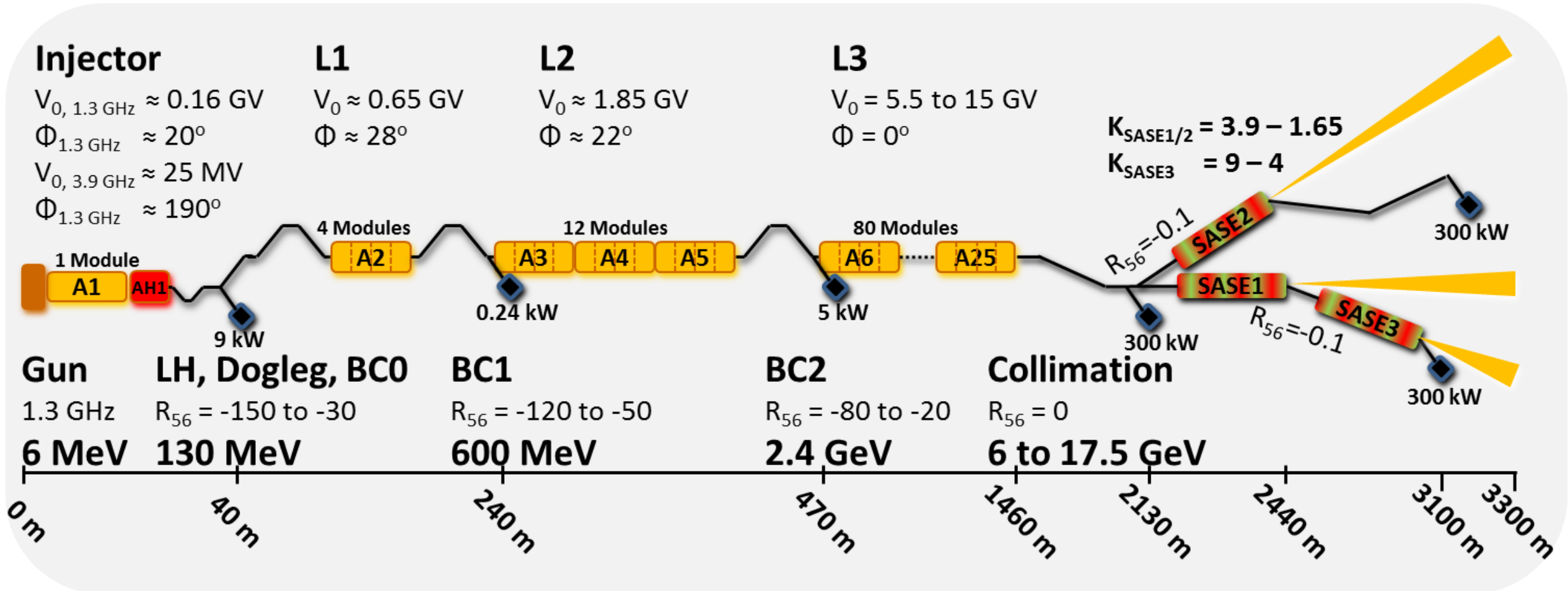

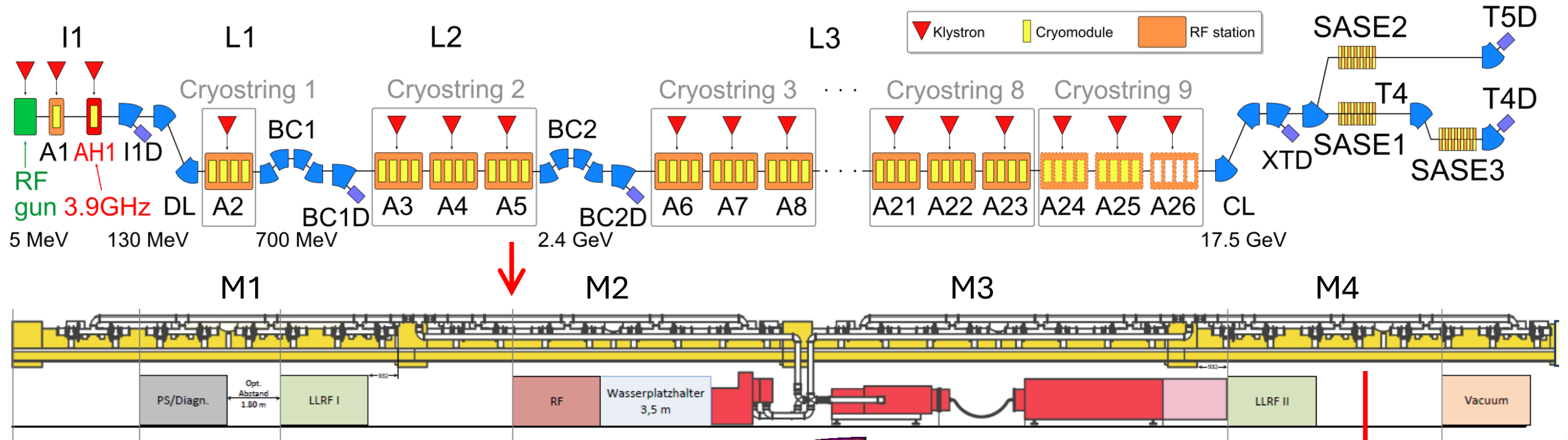

## RF Station

- 776 TESLA-type cavities
- 4 CMs, 32 cavities per XTL RF station
- Design energy 17.5 GeV
- Pulsed operation 10 Hz
- RF Pulse: 750 + 650  $\mu$ s

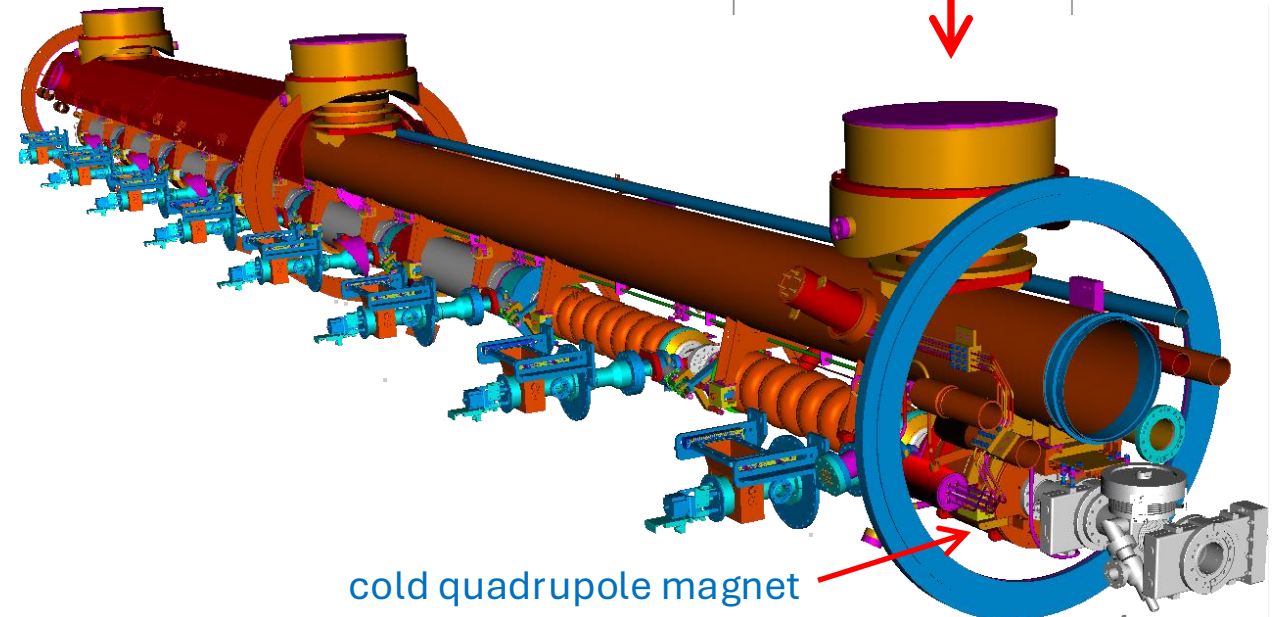

# Cavities accelerating gradients:

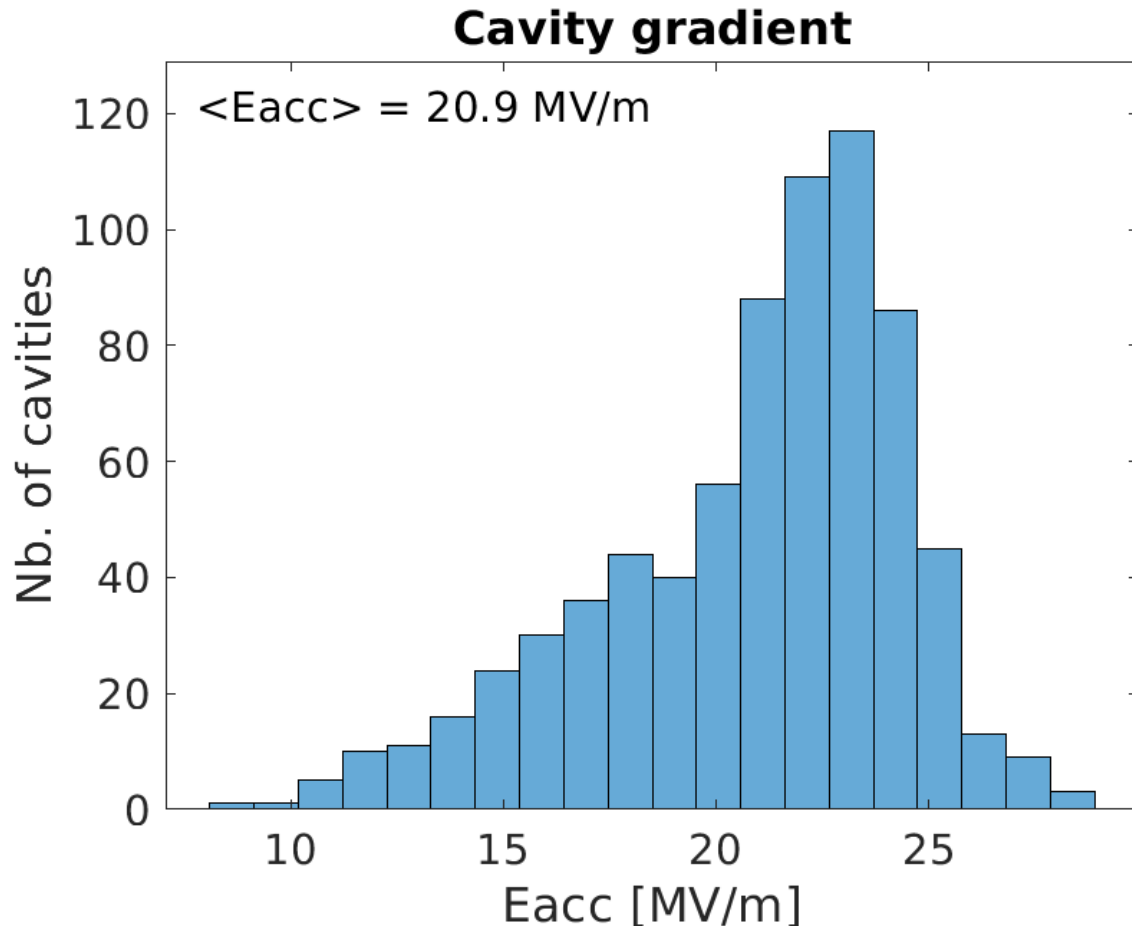

Cavity operating gradients for E-XFEL modules Vector Sum operation at current beam energy, optimized for operation (radiation etc.). These are not cavities maximum (operating) gradients.

Typical distribution : data from 6.11.2024 (last week during the 16.3 GeV study run)

# Instrumentation to measure/monitor radiation

- Type of sensors: RadFET, RadCon, MARWIN (gamma + neutrons)
- Locations and coverage of the machine: main tunnel XTL
- Continuous monitoring or interval of measurements: both
- Alternative ways to detect field emission: gamma chambers (1l)

# Radiation monitoring:

Detector	Type	Radiation	Sensitivity	Typical use
RadFet	integral	gamma	~0.01-0.1 Gy	Outside rack shielding. Continuous monitoring during operations
RadCon	rate	gamma	~0.1 $\mu\text{Gy/h}$	Inside rack shielding. Continuous monitoring during operations
MARWIN robot (mobile Pandora)	rate	gamma, neutron	~ 1 $\mu\text{Sv/h}$	Tunnel operation as needed (scheduled studies)

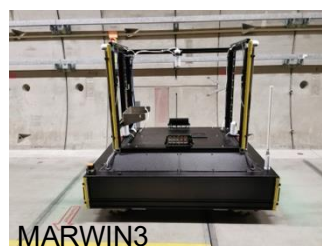
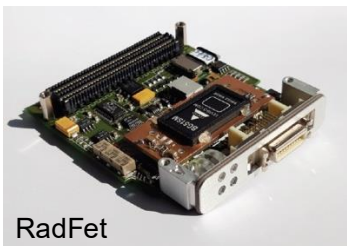

New field emitter detected

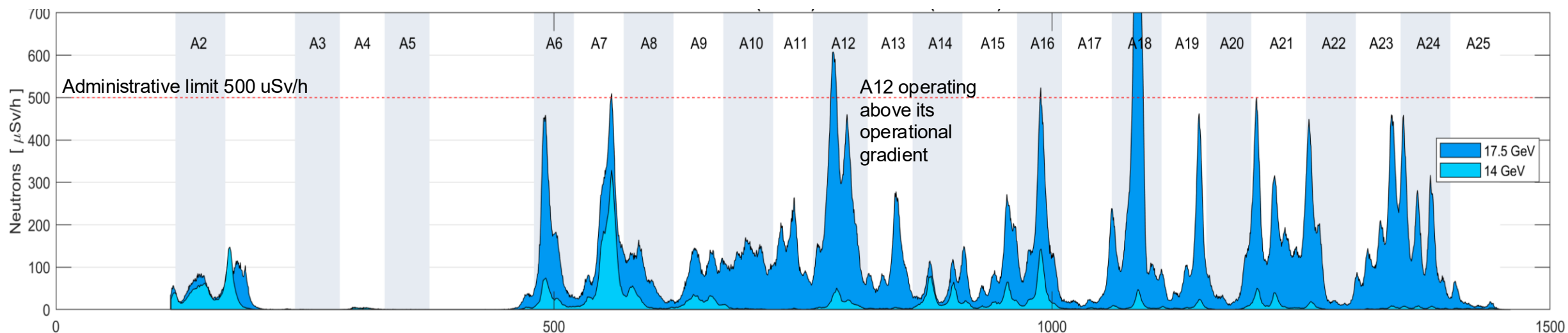

# Field emission situation during commissioning

- 103 CMs were built for E-XFEL linac, only 3 were FE free after testing in AMTF (gamma radiation measured  $< 10^{-5}$  mGy/min);
- FE / Gamma radiation operating limit is set to  $10^{-2}$  mGy/min;
- Vector Sum operation: some cavities detuned;
- Multipactor: in cavities at 19..25 MV/m, 50% needed conditioning;
- In the most (known) cases FE source is a particle contamination or dark current induced (new) emitter (sometimes conditionable);

# Evolution of field emission

- In total 8 cavities are detuned (not used) because of FE, mostly known cases from AMTF testing with 1 newly degraded. One high FE event with 2 cavities which were conditioned;
- Last newly degraded cavity is at the station A24 (A25 last one), conditioned high FE event happened at A5 – just before BC2;
- FE increase reasons sometimes are not clear. New emitter can be created with existing dark current, beam loss most probably is not the problem;
- Performance loss with all detuned FE cavities can be evaluated as  $\sim 190$  MeV, but as currently only one cavity did FE-degrade during operation this loss due to operation is  $\sim 25$  MeV (on 17.5 GeV level).

# Field emission remediation

- FE conditioning was attempted (apart from commissioning) to a couple of cavities. One case did not succeed, one did;
- In case of 2 FE-degraded cavities in A5 performance is fully restored;
- We did not (yet) remove any cryomodules. In our cavity/CM tests a high FE cavity can be remediated with HPR, given the prior CM disassembly;
- FE conditioning in CM in situ needs (in our experience):
  - single cavity operation;
  - gamma radiation measurement;
  - short RF pulse operation;
  - lowest possible cavity  $Q_{\text{load}}$ ;
  - highest possible RF power.

# List of detuned cavities (status Nov. 2024):

Station	Count	Cavity	Reason	Date detuned	Comment
A4	1	M4.C4	Coupler (T70K)	< 2017	
A6	4	M1.C3	High FE/X-Ray	25.01.2023	MARWIN neutron >500uSv/h
		M3.C1	High FE/X-Ray	< 2017	AMTF
		M3.C5	MGTF (quench)	2018-2019	
		M3.C6	MGTF (quench)	2018-2019	
A7	3	M1.C7	MGTF (quench)	21.11.2018	Operational degradation observed on 02.11.2018
		M2.C3	MGTF (quench)	2018-2019	
A7		M2.C7	High FE/X-Ray	< 2017	AMTF
A10	1	M1.C3	Low-field quench	< 2017	AMTF
A12	3	M2.C2	MGTF (quench)	2018-2019	
		M3.C8	MGTF (quench)	2018-2019	
		M4.C1	Coupler (T70K)	< 2017	
A14	1	M3.C5	Excess cryogenic losses	2017 commissioning	
A16	1	M2.C1	Coupler (T70K)	< 2017	
A18	2	M4.C4	AMTF WDS spec error	< 2017	
		M3.C4	High FE/X-Ray	23.09.2020	MARWIN neutron >500uSv/h
A20	1	M4.C1	Coupler (T70K)	< 2017	
A21	2	M3.C4	Low-field quench	< 2017	AMTF
		M4.C2	MGTF (quench)	2018-2019	
A22	1	M4.C3	High FE/X-Ray	14.01.2020	MARWIN neutron >500uSv/h
A23	2	M4.C4	High FE/X-Ray	19.09.2021	MARWIN neutron >500uSv/h
		M3.C7	High FE/X-Ray	19.04.2022	MARWIN neutron >500uSv/h
A24	2	M2.C7	High FE/X-Ray	25.10.2019	FE event (activation)
		M2.C8	Low-field quench	07.09.2023	
<b>Total</b>	<b>24</b>				

Cavities with issues known before commissioning, never operated

Cavities detuned to stay below administrative radiation limit

Cavities where a field degradation was observed during operation

Cavities detuned to improve the vector-sum gradient \*

\*(decision could be revised, on a case by case)

8 cavities in 6 CMs are currently detuned (not in use) because of high FE. 7 cases known from AMTF, 2 of them detuned already during commissioning.

One cavity FE related degradation happened more recently.

# Field emitter remediation example:

## Example Module A18.M3.C4

### Procedure

- Park MARWIN at peak neutron radiation (often located at quadrupole)
- Detune / retune cavities one at a time until field emitter is found
- Once found, detune field emitter (30-40 kHz)

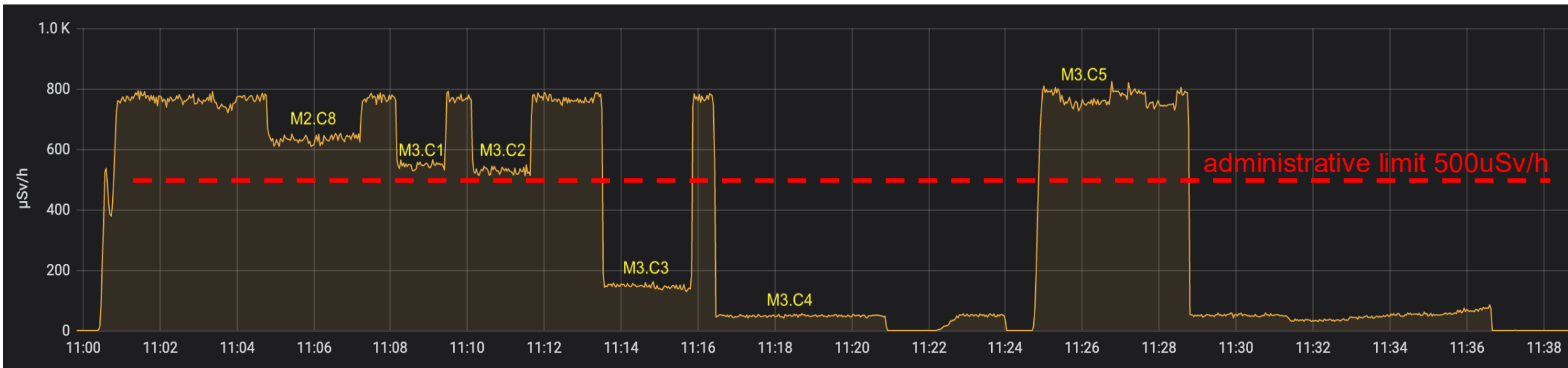
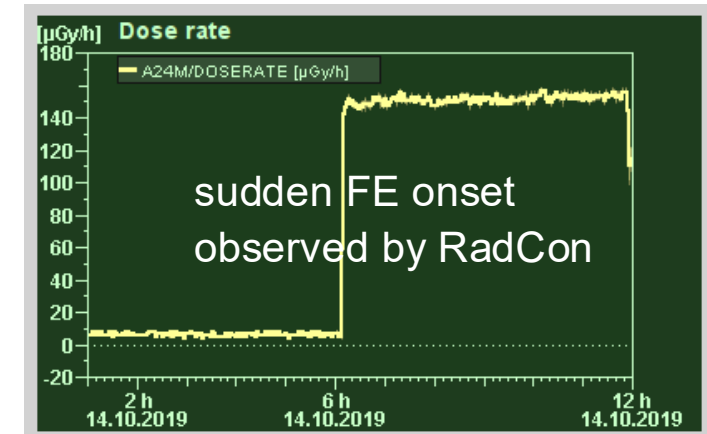

# MARWIN last data (17 GeV)

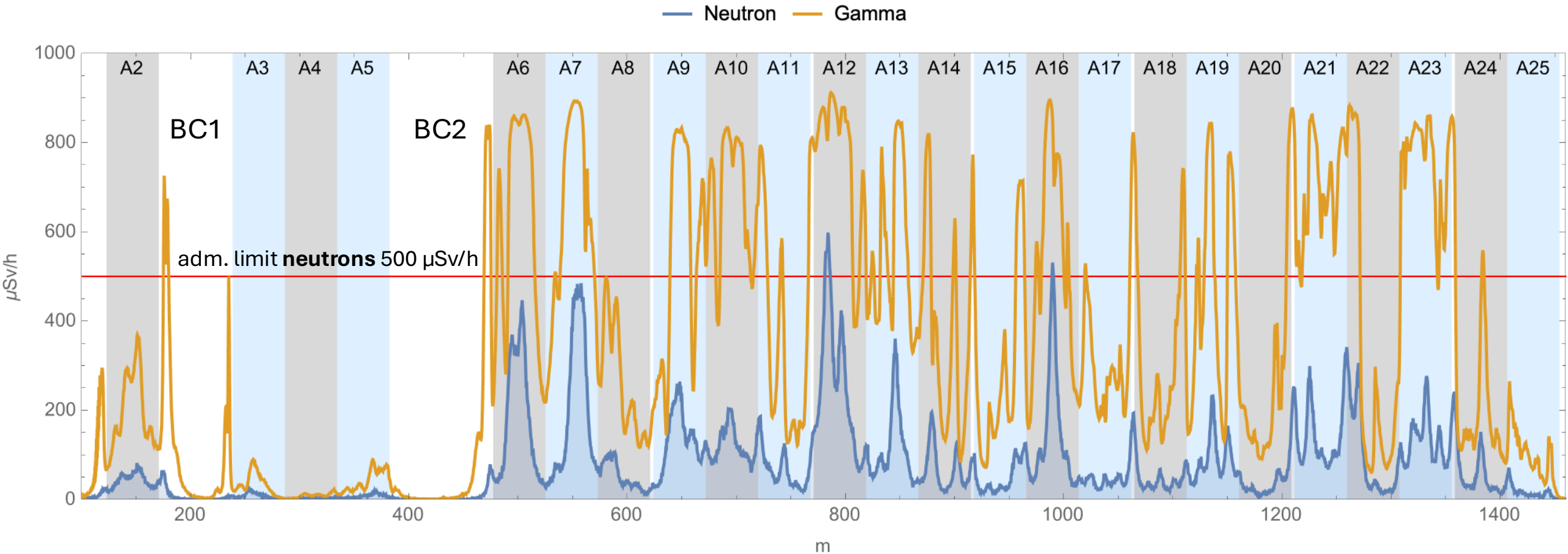

# RF station A5 event:

After shutdown in April 2018 RF power at L2 was ramped up to SP=800MV too fast after previous (year) operation at 600MV. This caused a high dark current. High dark current is most probably the source of 2 cavities degradation with high FE – C7/C8.M4.A5. Also the SC-Quads were off at the moment, which may cause some dark current transport in the linac.

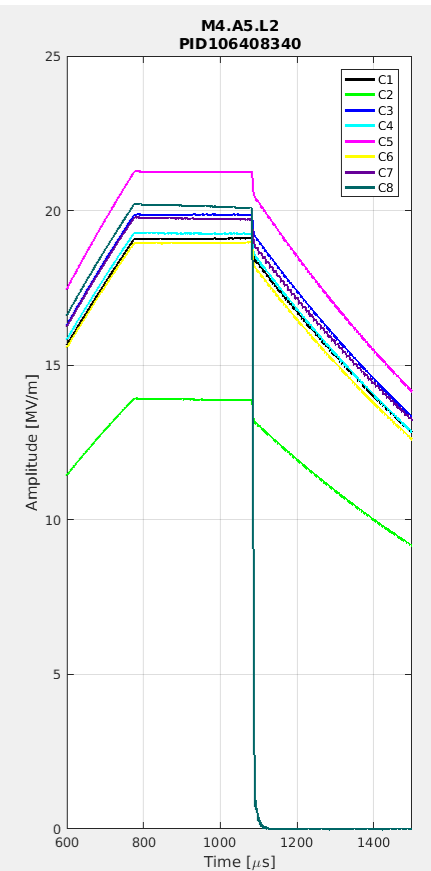
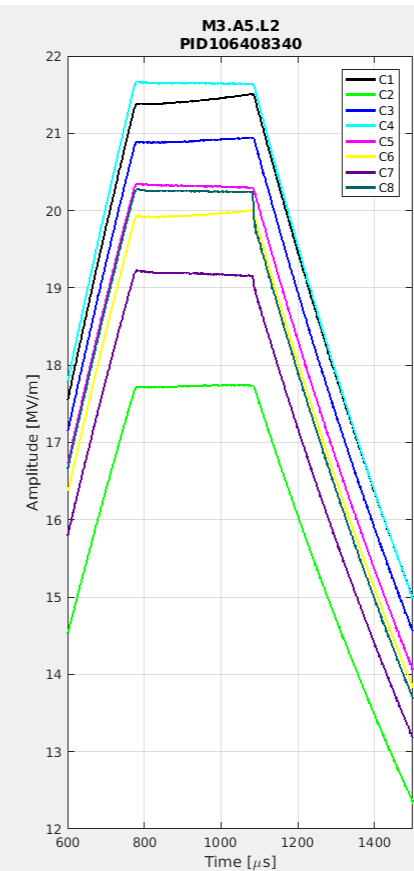
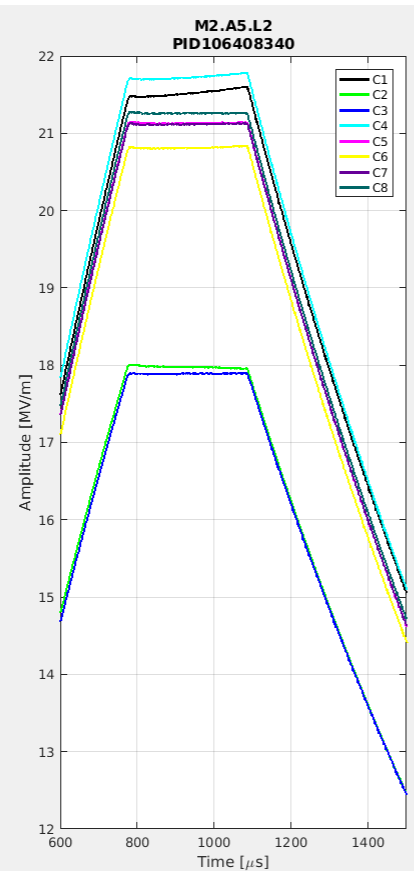
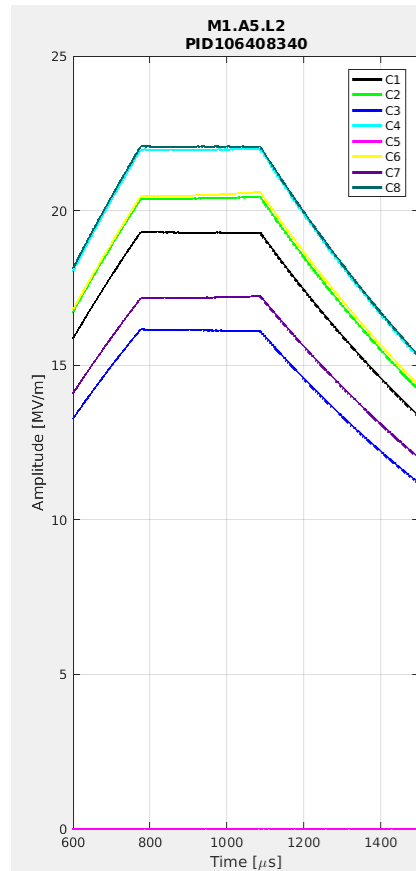
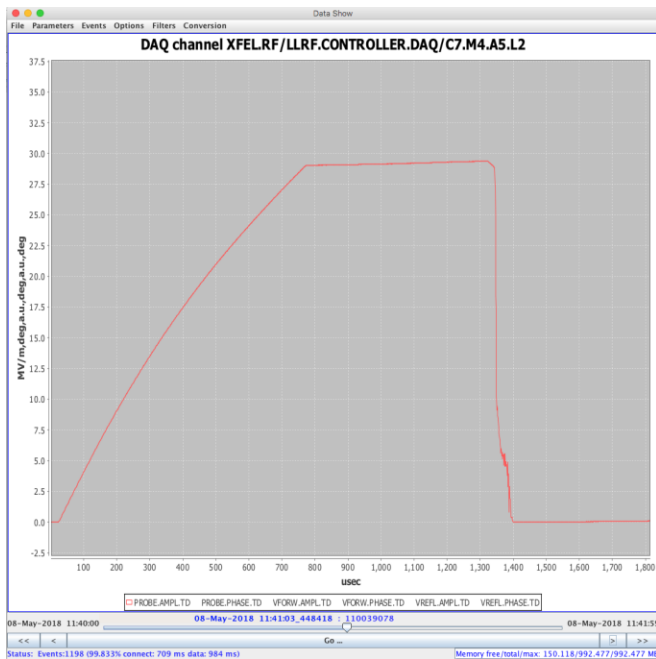

# RF station A5 conditioning:

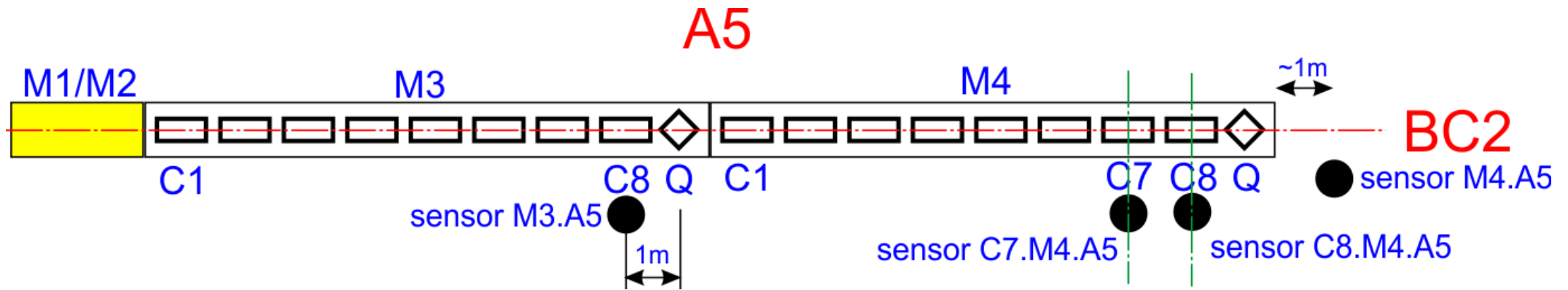

- A5 MP conditioning with C7/C8 was done with slow increasing the gradient separately with C8 and C7;
- A5 final gradients after MP conditioning (SP = 800 MV):

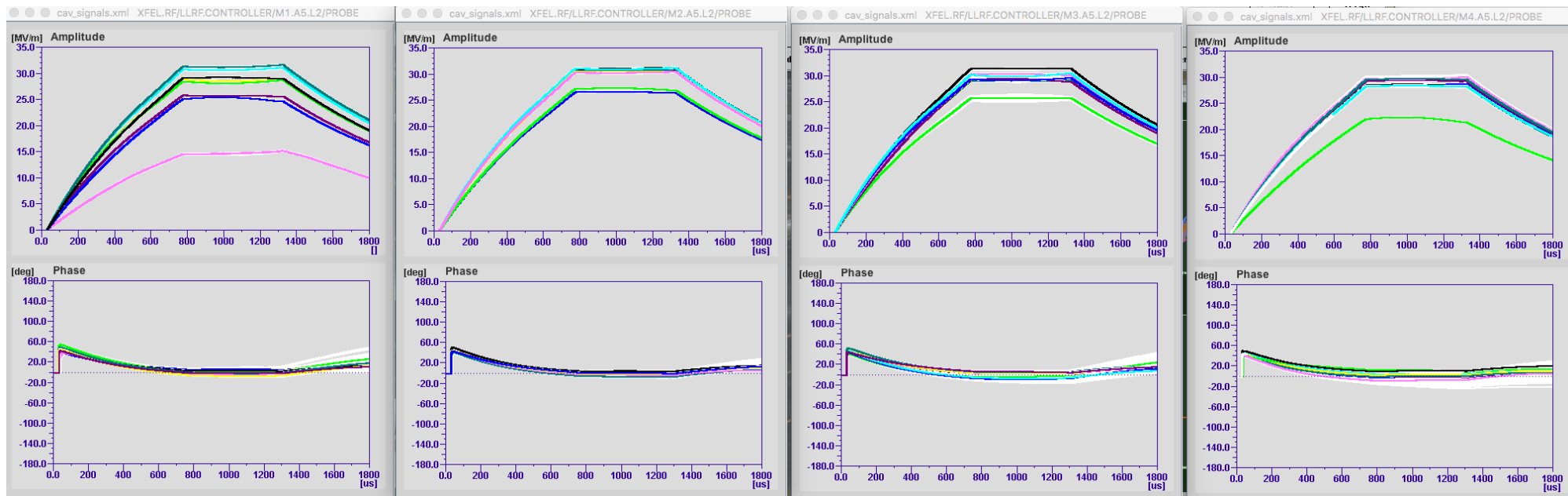

# In addition: FLASH ACC2&3 commissioning:

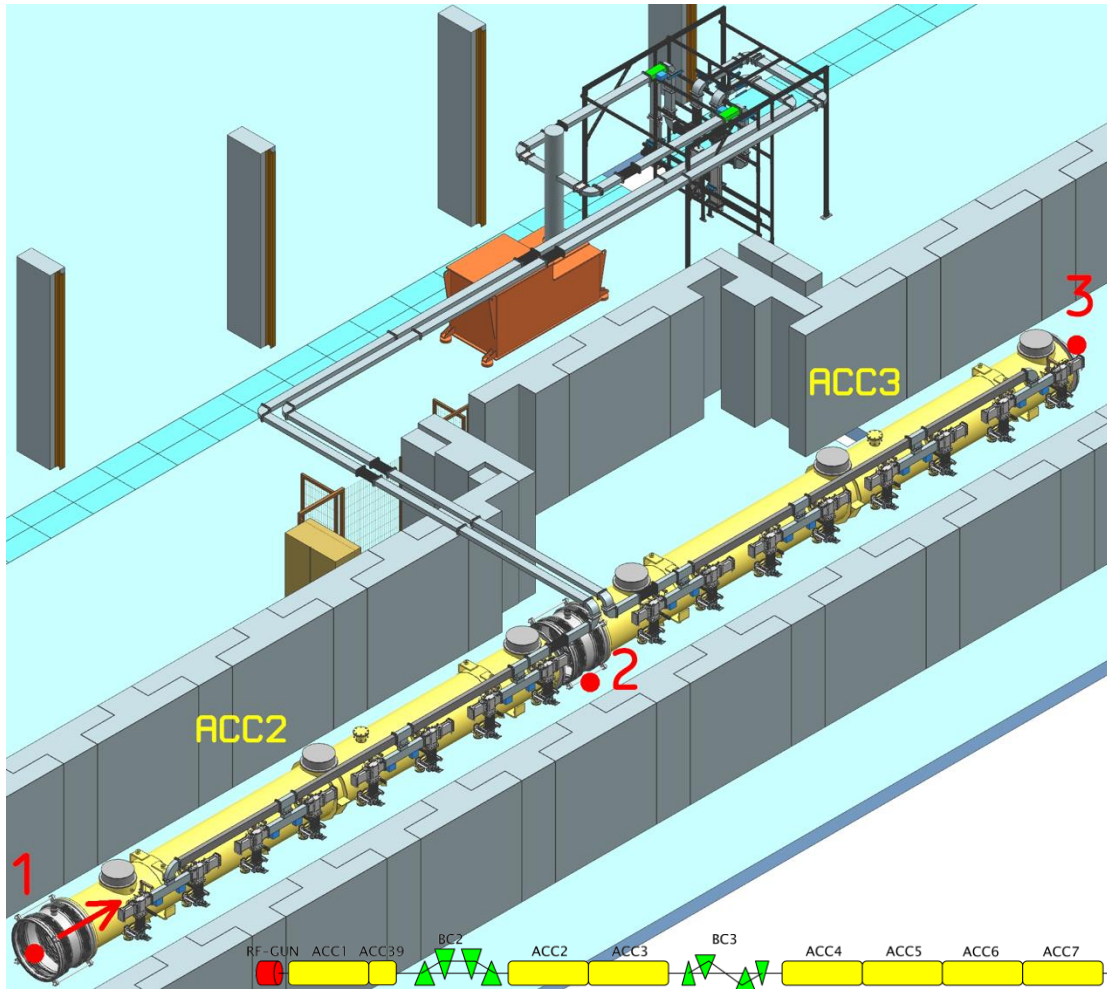

PXM2.1 and PXM3.1 with RF power distribution in FLASH (red dots are X-ray sensors 1,2,3) (see MOPMB082 SRF2023)

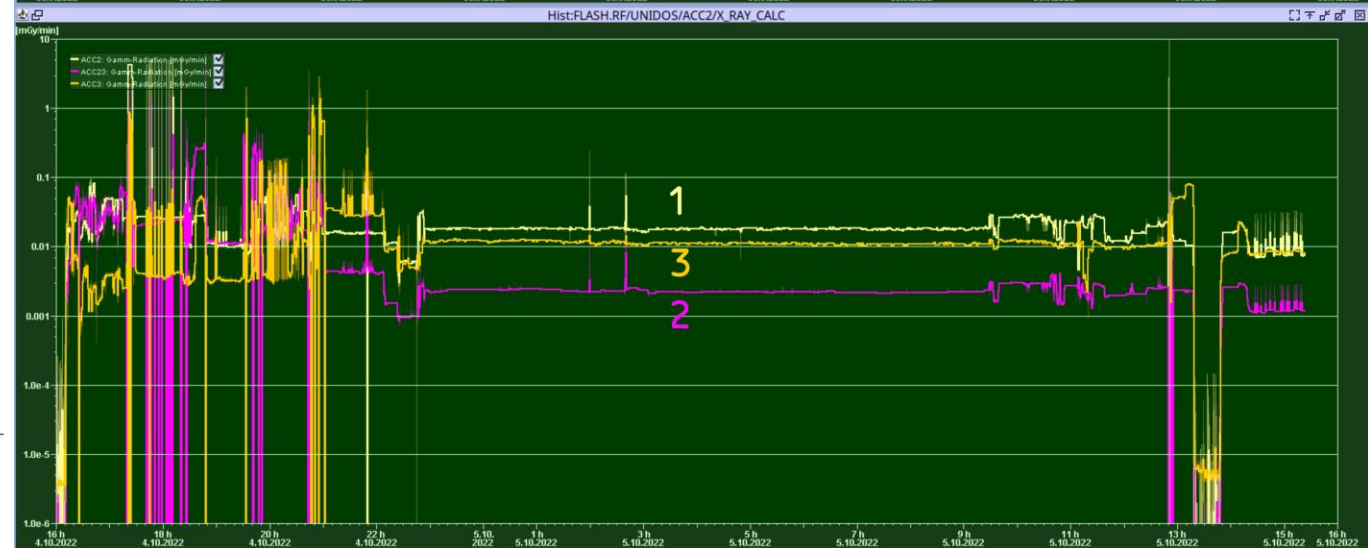
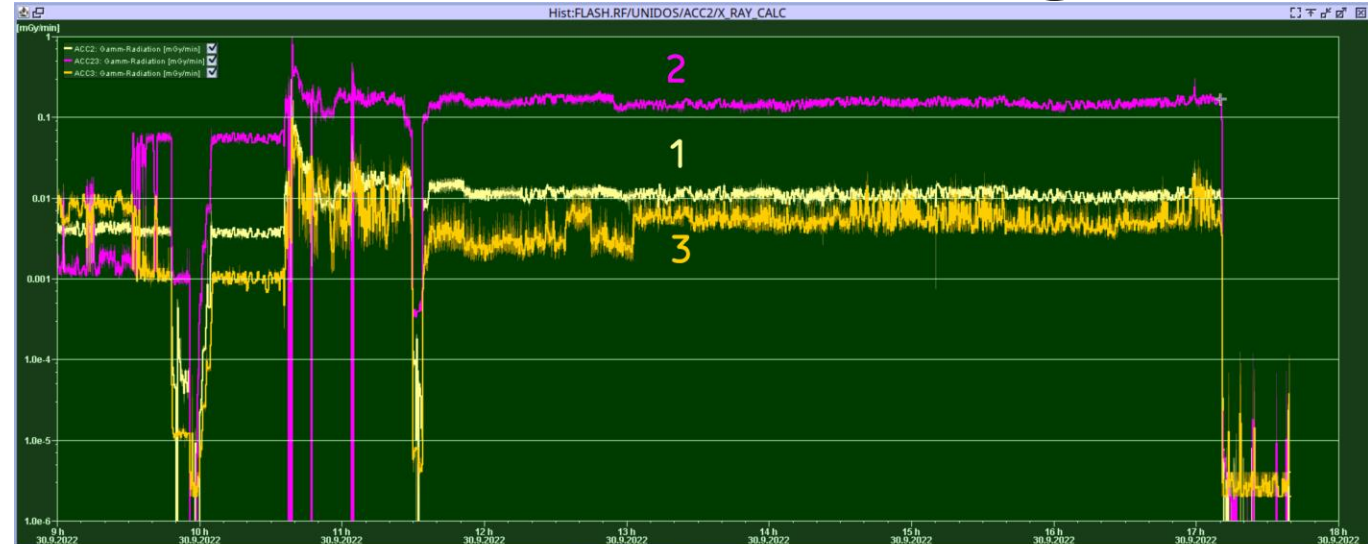

FLASH ACC2&3 gamma radiation decreased during commissioning