



# in the Higgs Factory context

Caterina Vernieri, Emilio Nanni  
NIKHEF October 8, 2024

[web.slac.stanford.edu/c3/](http://web.slac.stanford.edu/c3/)

# Higgs Factories

## THE TOHOKU REGION OF JAPAN



250/500 GeV

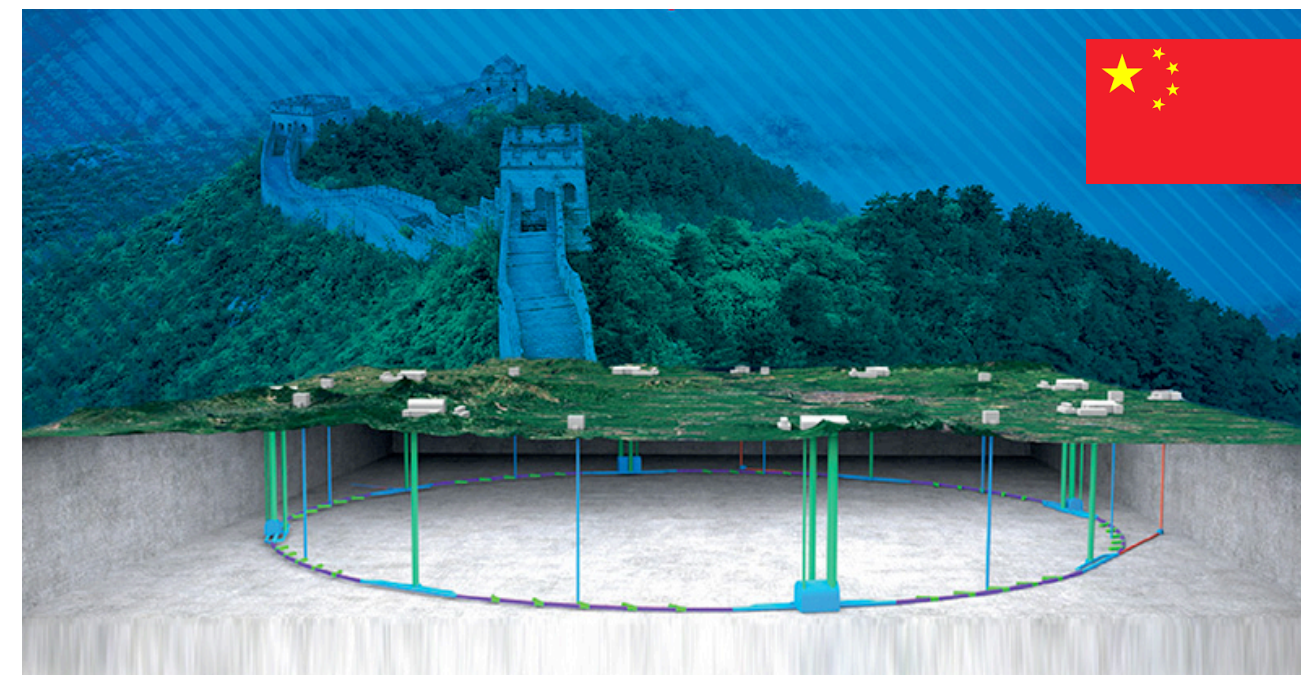

CEPC 240 GeV



COOL COPPER COLLIDER

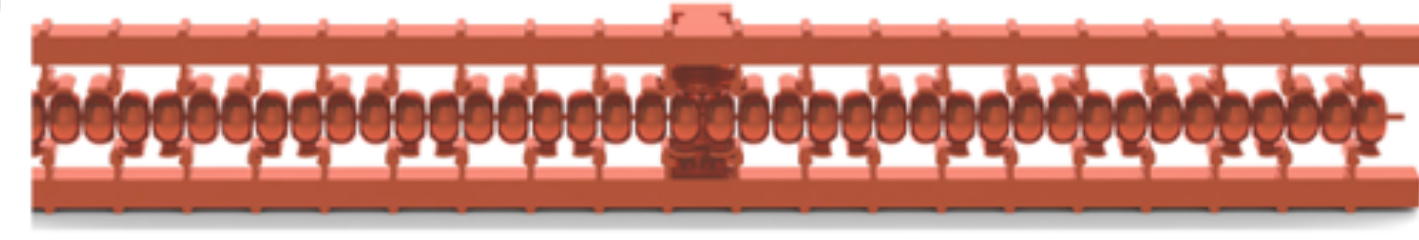

250/550/... GeV

## CLIC 380/1500/3000 GeV

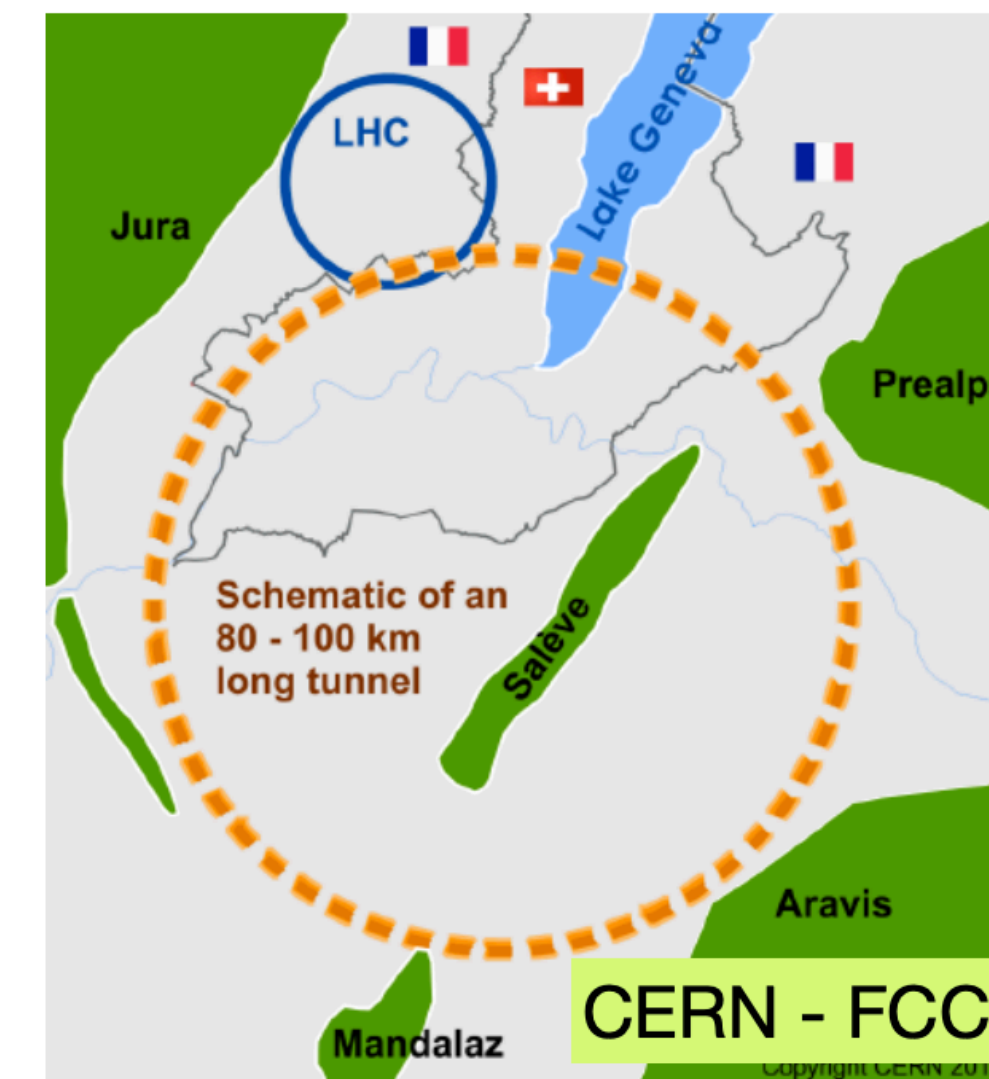
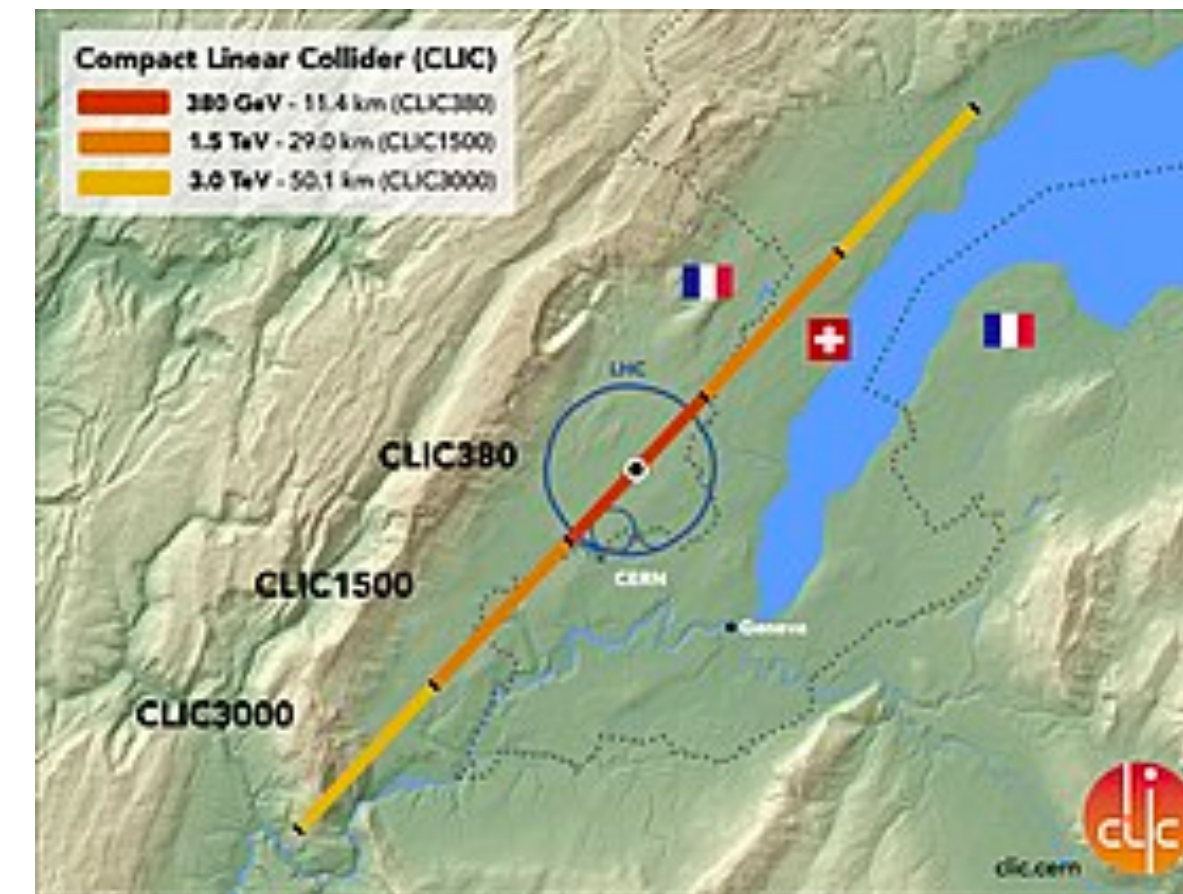

FCC-ee  
90/240/365 GeV

# Higgs Factories

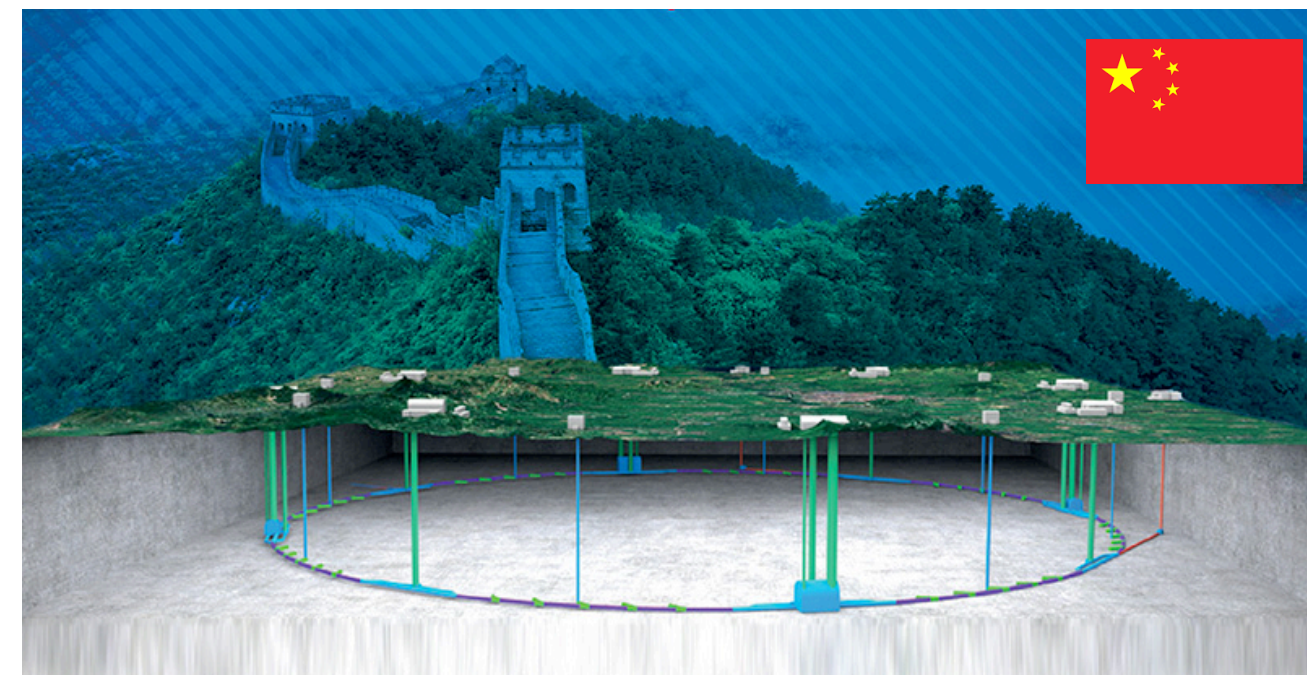
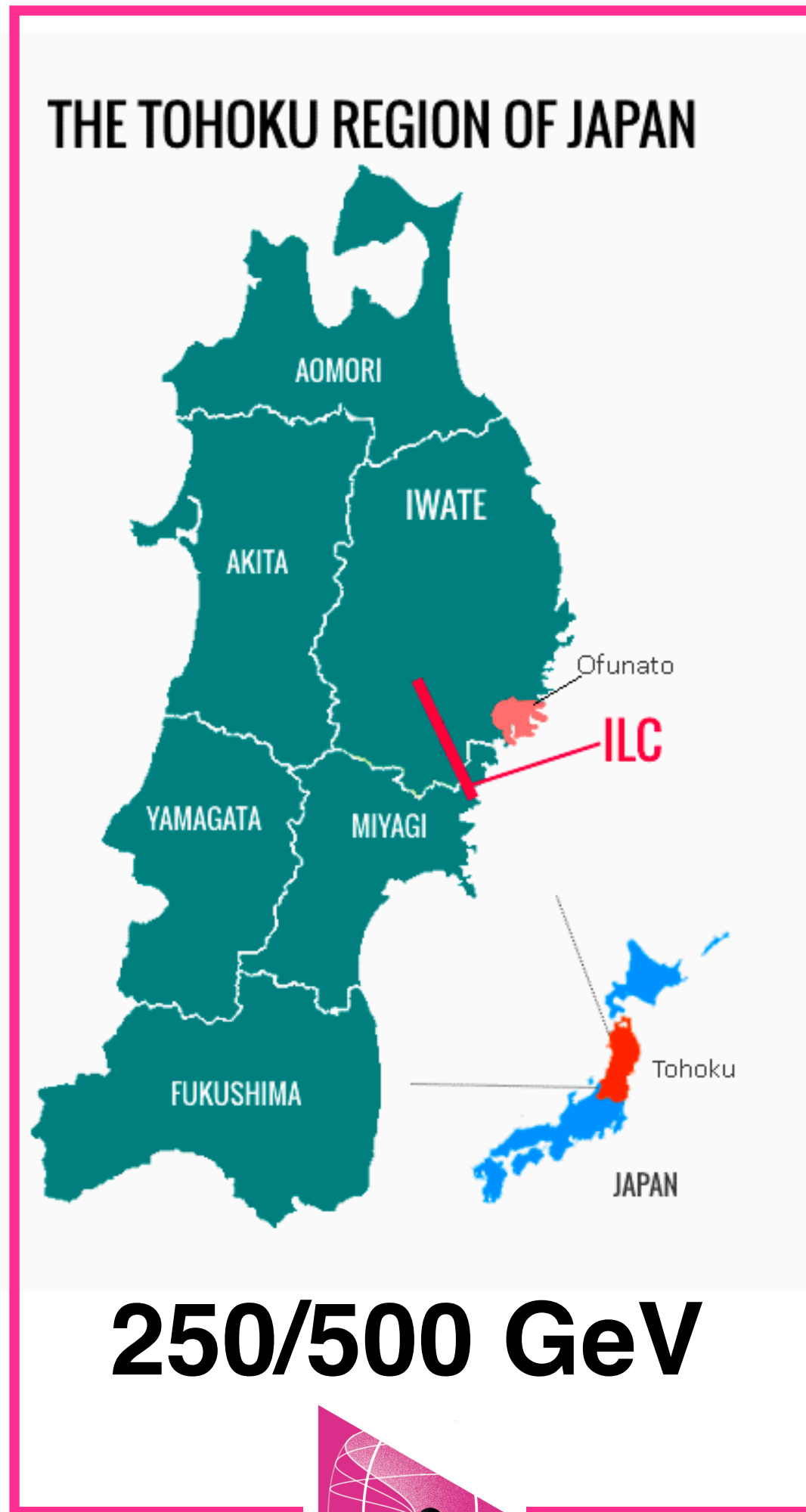

**CEPC 240 GeV**



**COOL COPPER COLLIDER**

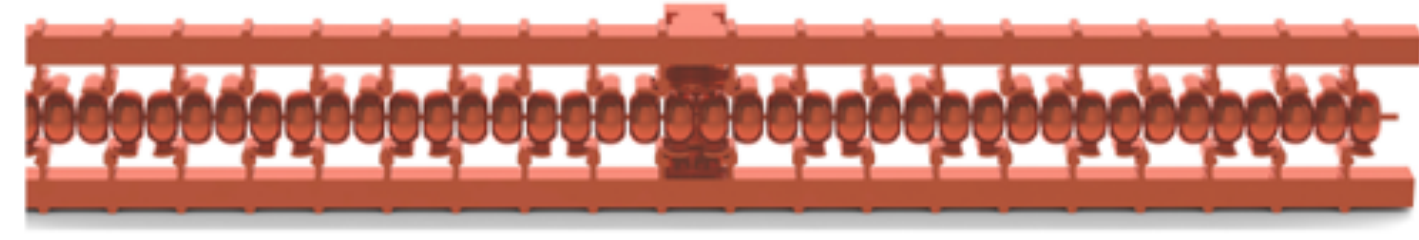

**250/550/... GeV**

**CLIC 380/1500/3000 GeV**

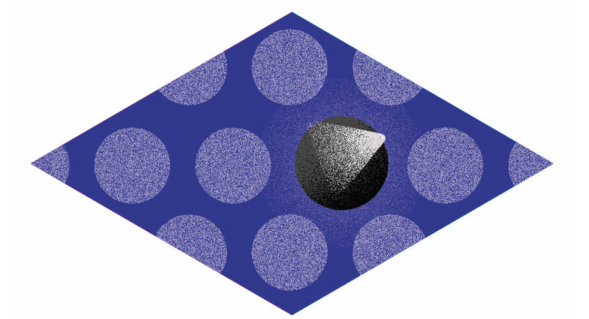
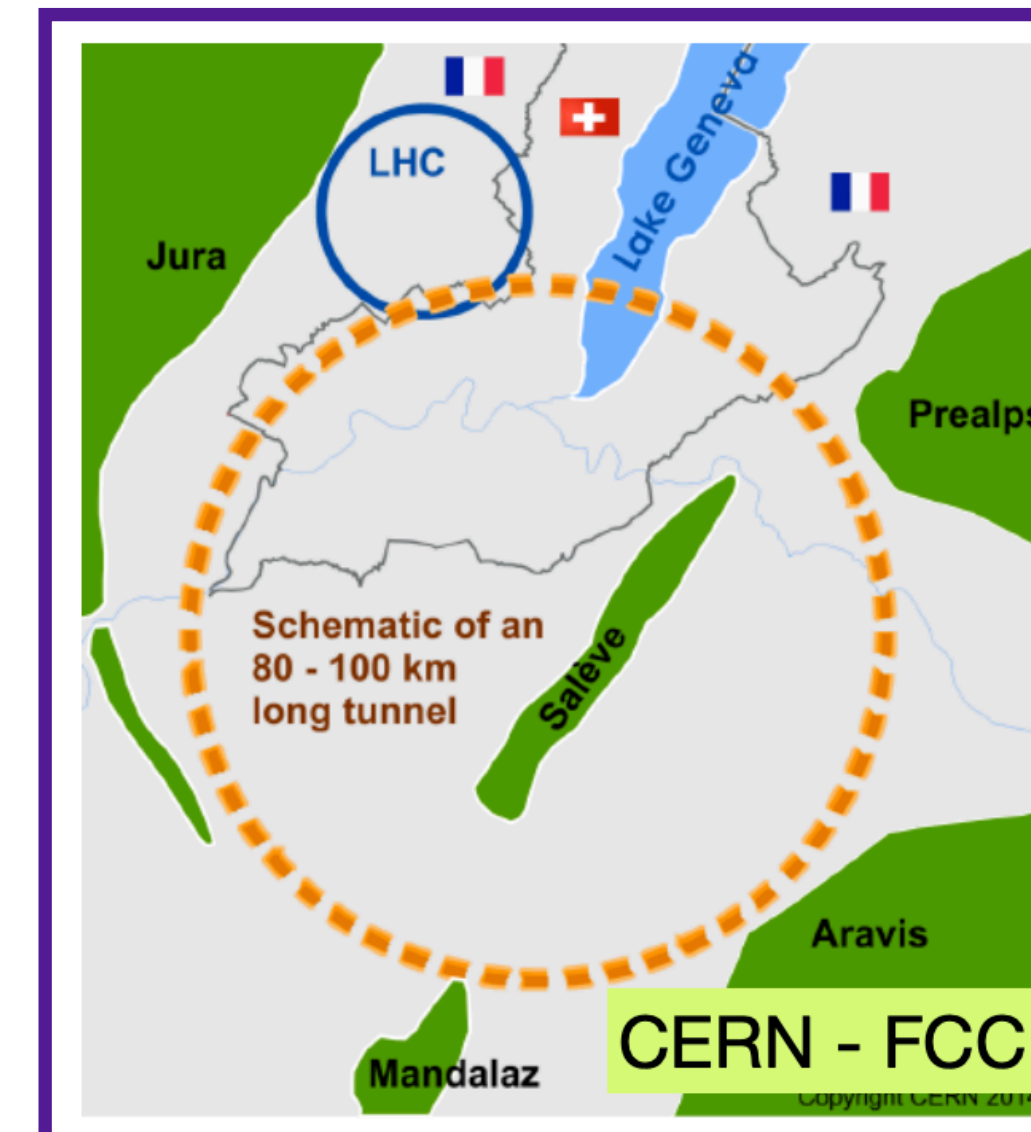
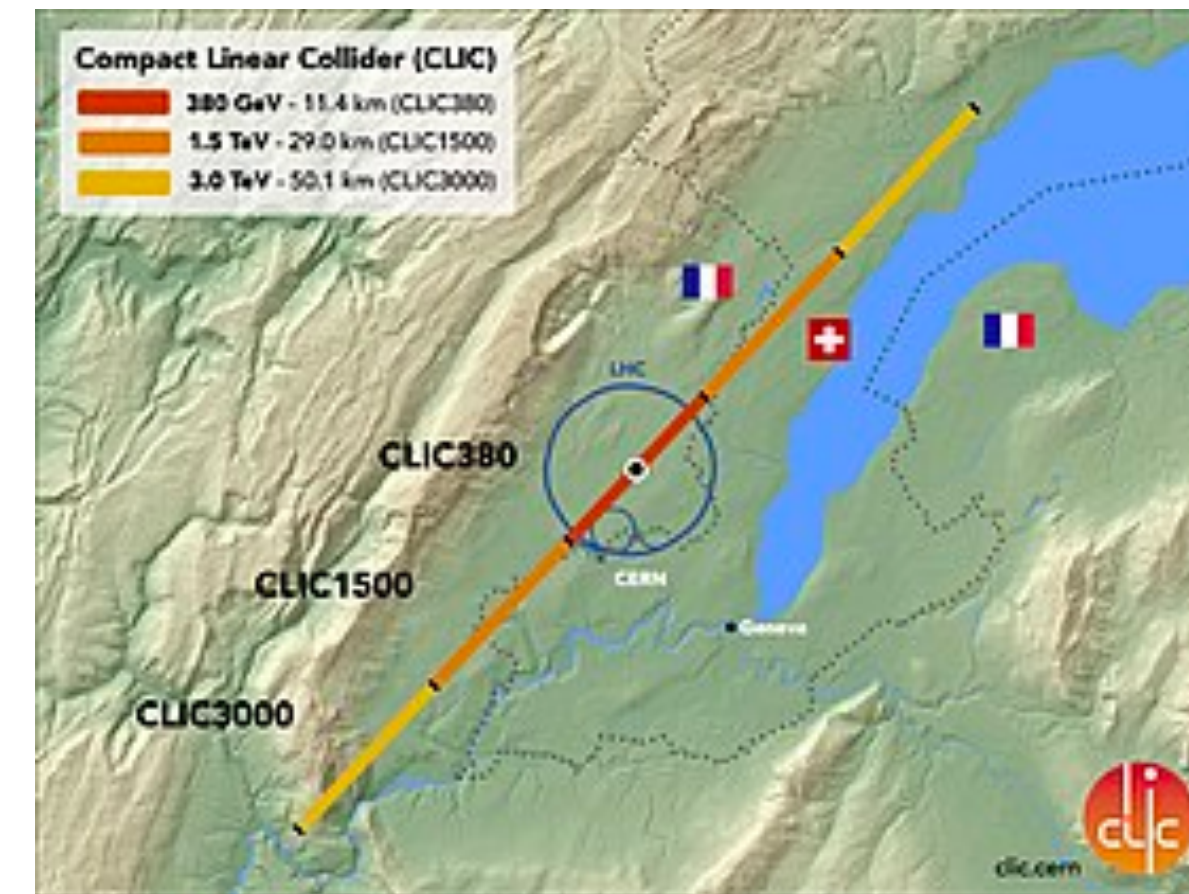

**FCC-ee**  
**90/240/365 GeV**

# Post P5, motivating accelerator R&D

P5 report

Enabling the machines of the future

“Incorporate innovative concepts like cryogenic **cool copper** in the normal conducting RF program”

**Area Recommendation 8:** Future test facilities could include the **cool copper** test for high gradient RF technology

Accelerator technologies play a key role in **sustainability**

“Accelerator structure improvements can also play an important quality factor, and concepts like **cool copper**.”

**Area Recommendation 20:** HEPAP, potentially in collaboration with international partners, should conduct a dedicated study aiming at developing a sustainability strategy for particle physics.



# Cold Copper RF R&D

Cold-copper program has focused on understanding fundamental limits

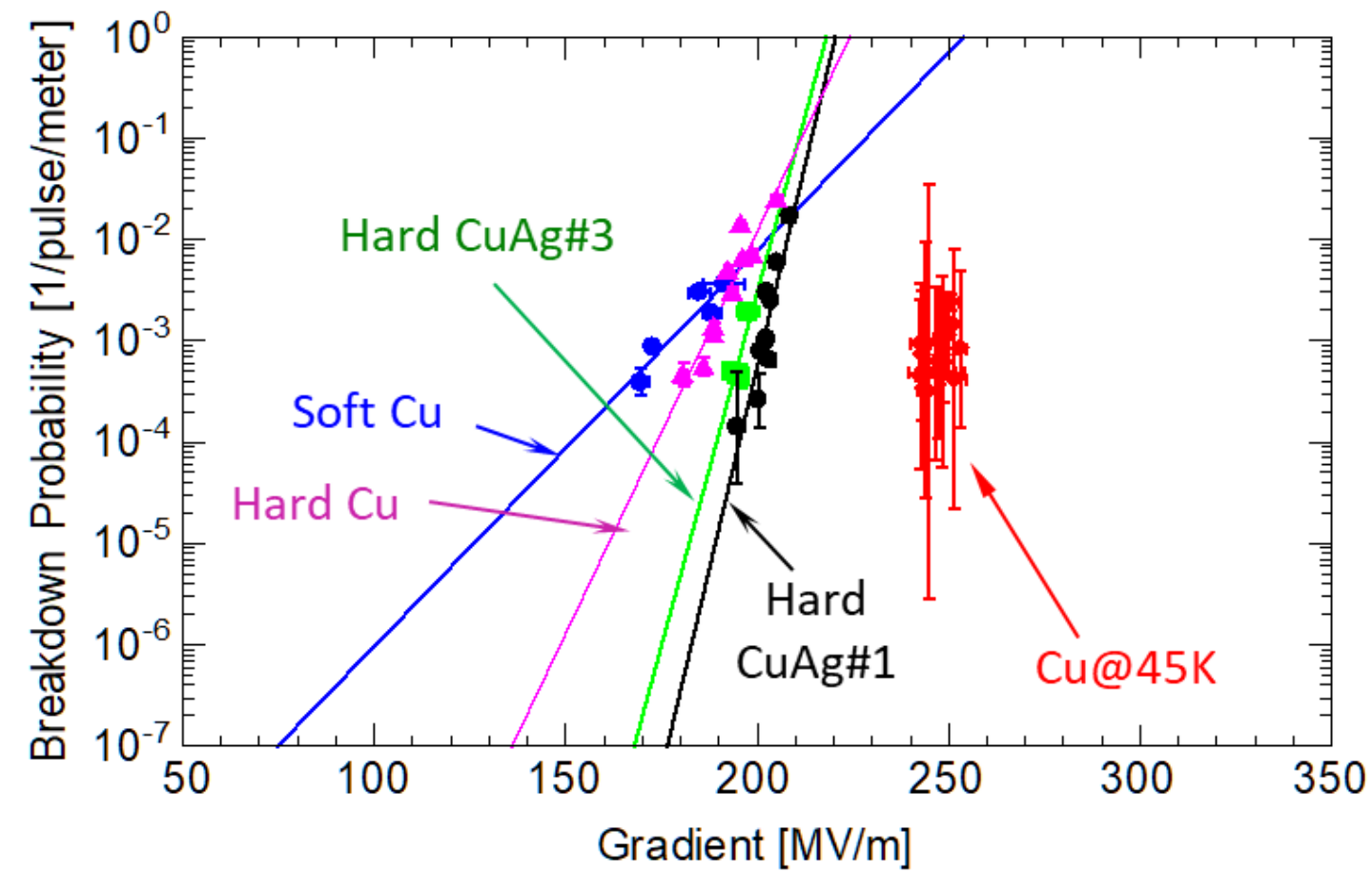

[High Gradient Workshop \(2015\)](#)  
[PRAB 21, 102002 \(2018\)](#)

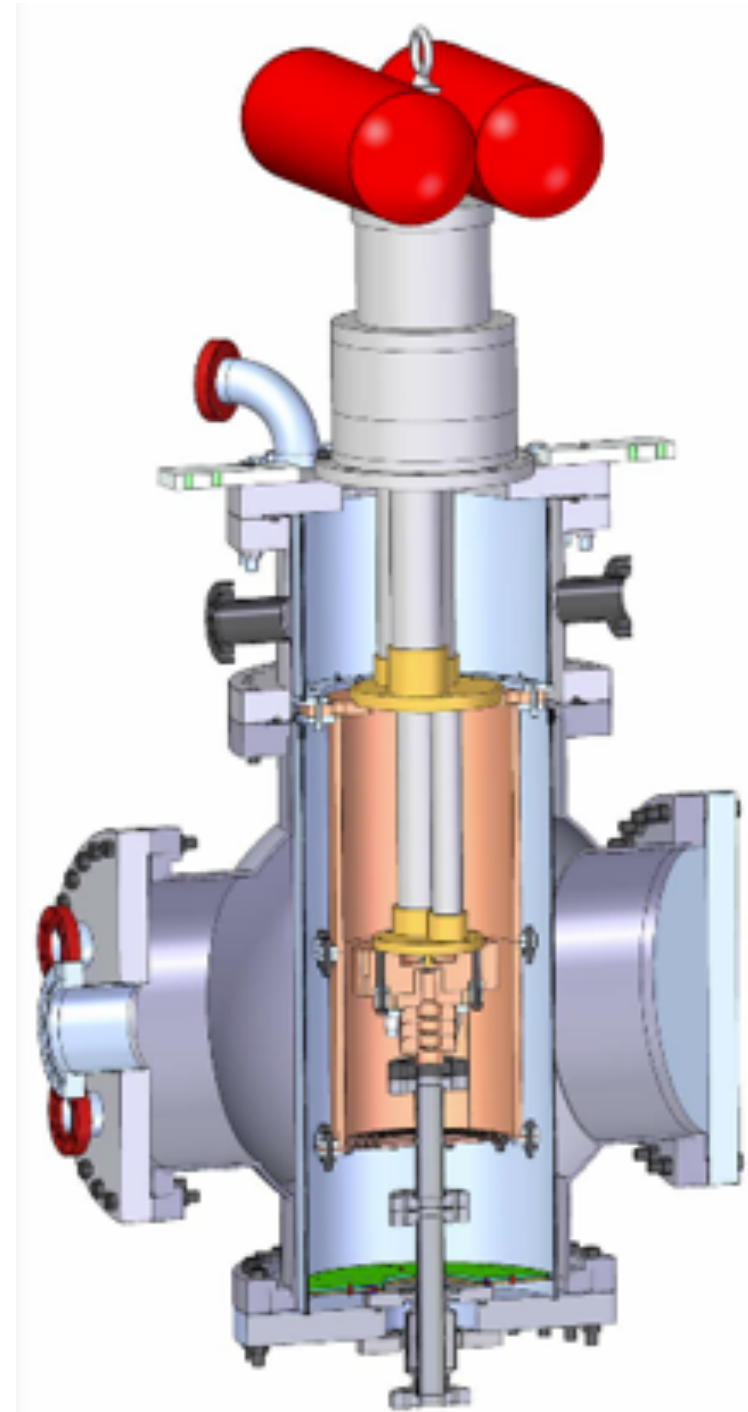

- What gradients can we achieve?
- How efficient can we make these structures?
- How do we achieve and maintain precision alignment?
- Can we preserve beam quality with damping and detuning?
- Can we operate at higher beam powers?
- Is this concept scalable?

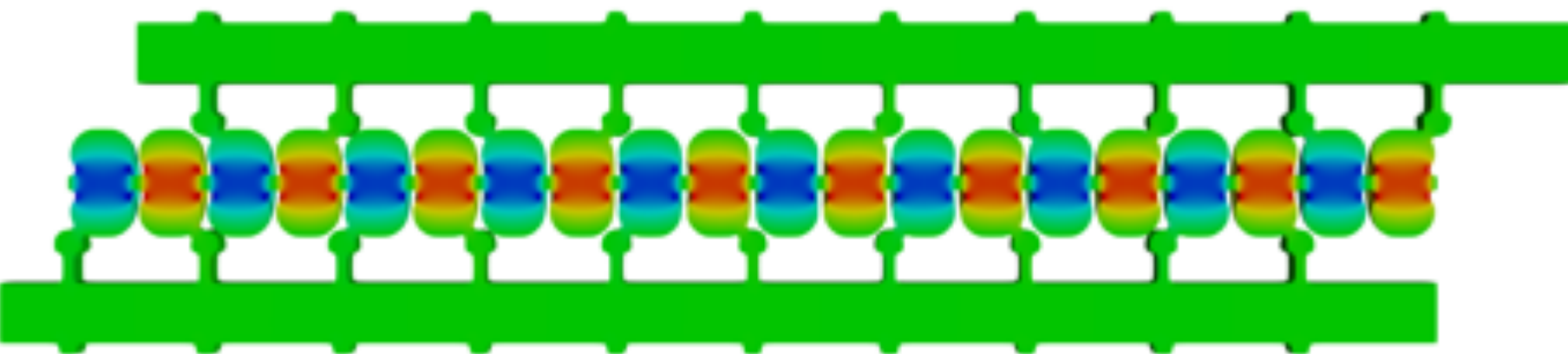

[arXiv:1811.09925 \(2018\)](#) [PRAB 23, 092001 \(2020\)](#)



# Single Cell High Gradient Tests with Cu and CuAg Cavities

High power tests at LANL (room temp) and Radiabeam (cryo) with up to 5 MW per cavity

- Improved coupler design significantly reduced breakdown probability
- **C-band cavities were able to reach gradients over 250 MeV/m in cryogenic tests**
  - C-band is a sweet spot for driving high power beams with high efficiency
- **All tests are done off-site due to lack of on-site high power C-band sources**

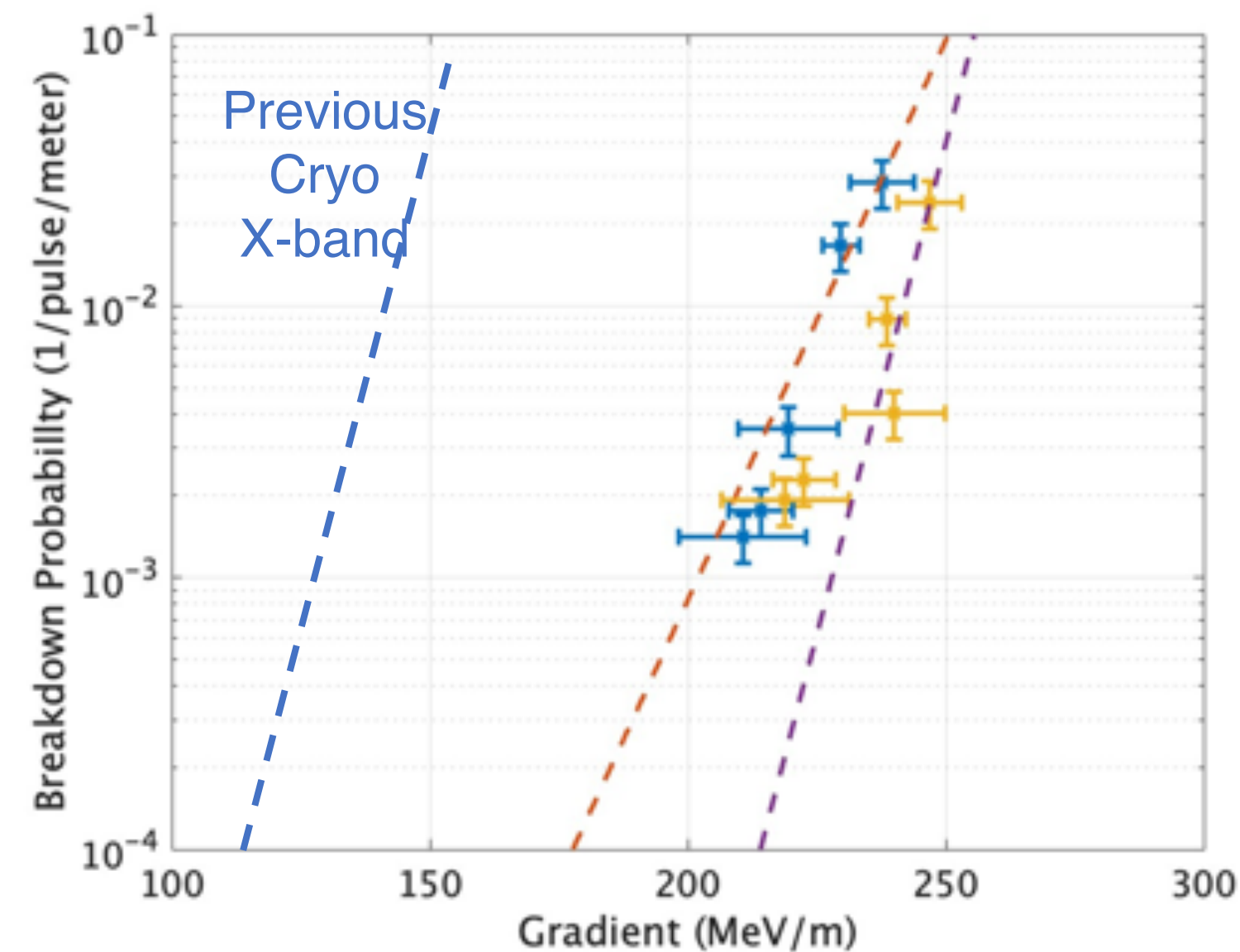
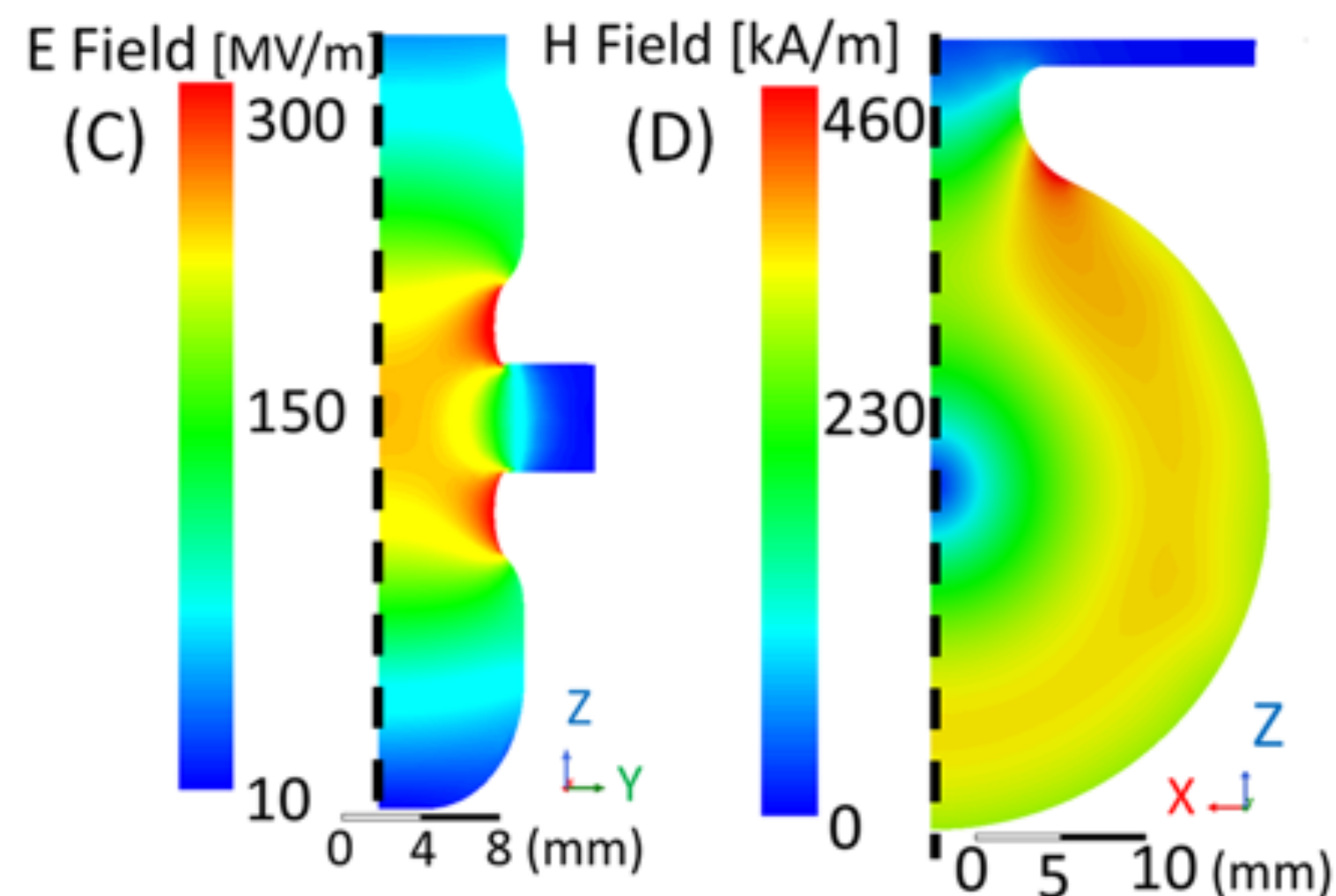
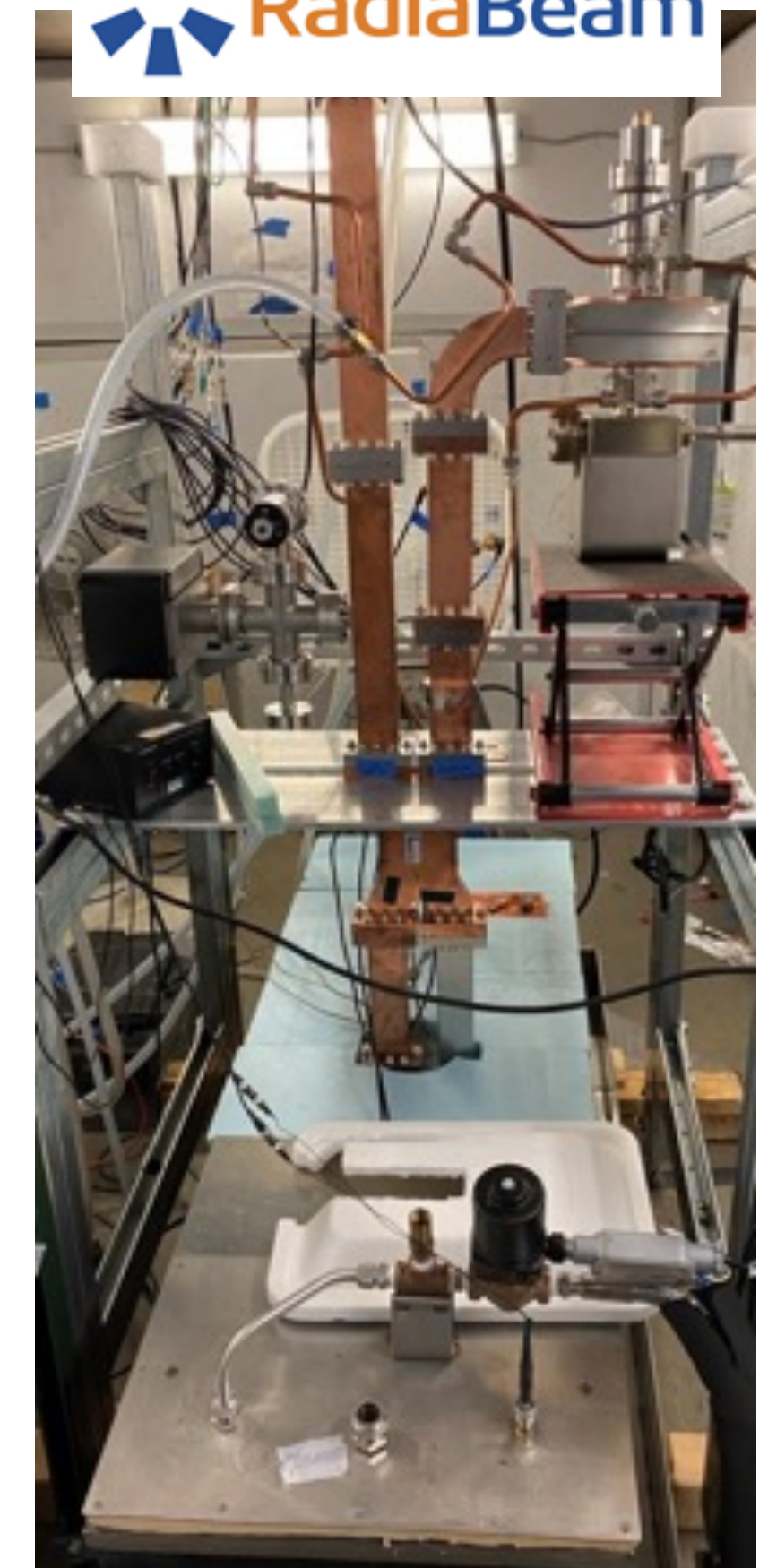

[APL 121, 254101 \(2022\)](#)  
[IPAC2024 p. MOPR29](#)

**Improved RF design further enhances the achievable gradient**

# Linac Proposals or Technologies for Future Upgrades?

ILC  
250/  
500  
GeV

THE TOHOKU REGION OF JAPAN

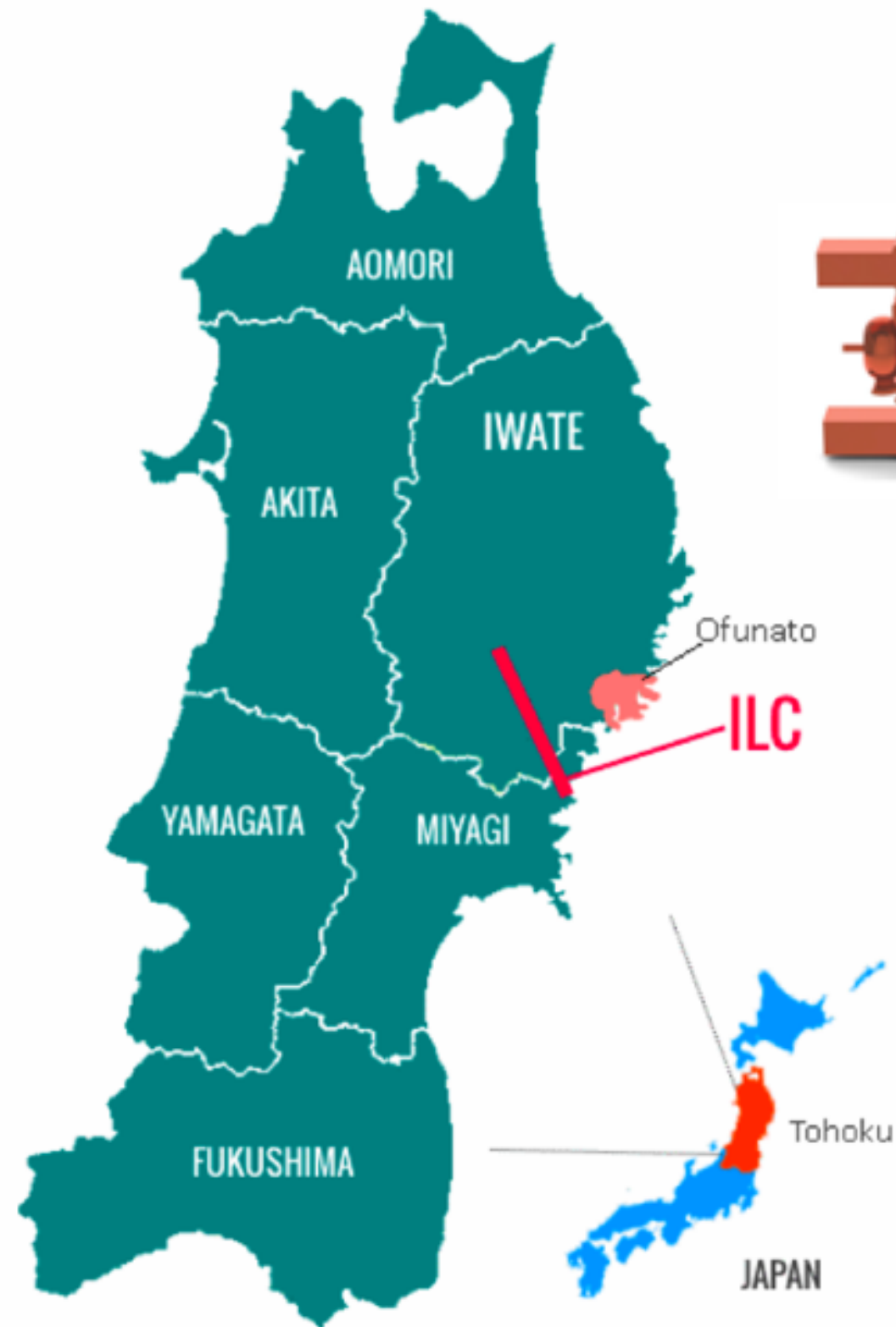

**C<sup>3</sup>** 250/550 GeV  
... > TeV

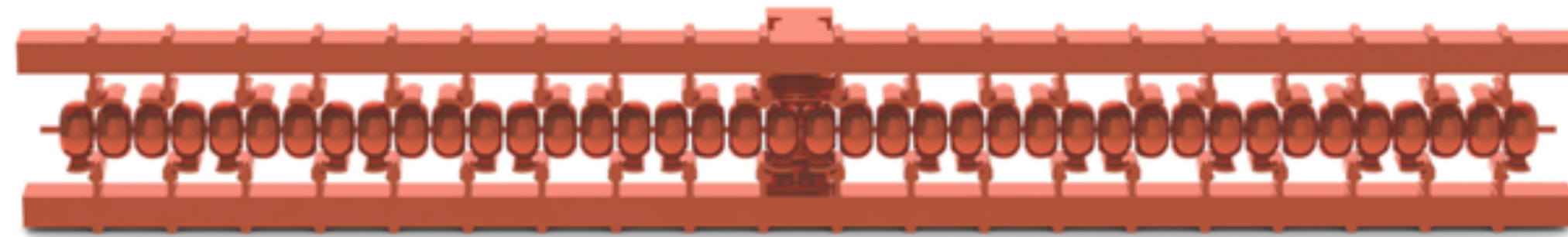

XCC s-channel  $\gamma\gamma \rightarrow H$  @  $\sqrt{s} = 125$  GeV

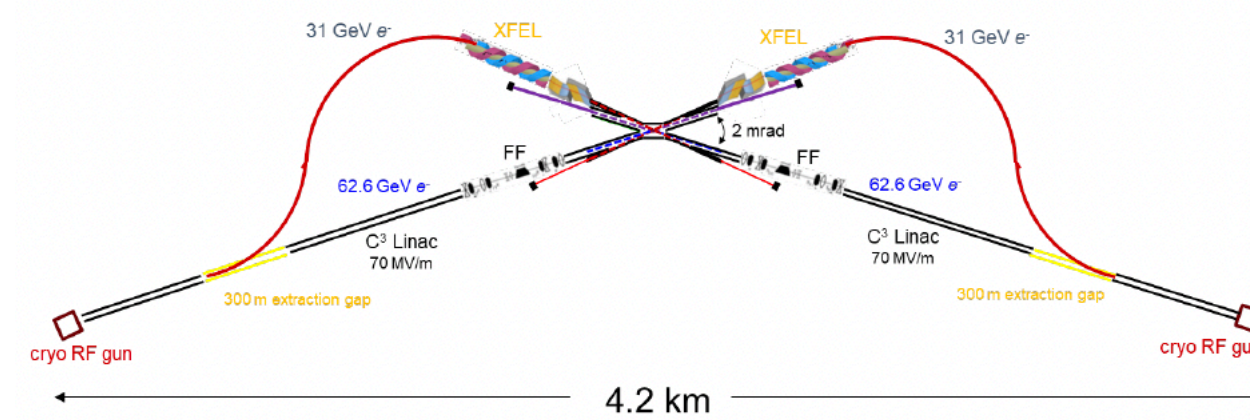

Recirculating  
Linacs

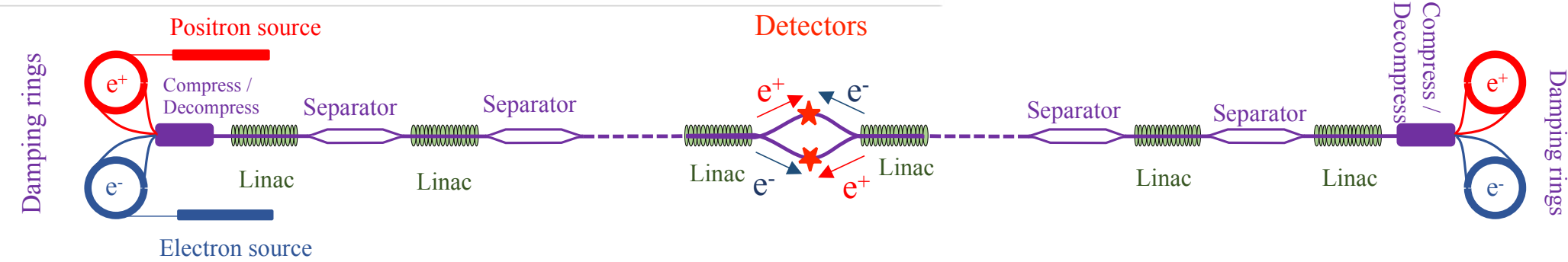

Wakefield  
Accelerators

CLIC 380/1000/3000 GeV

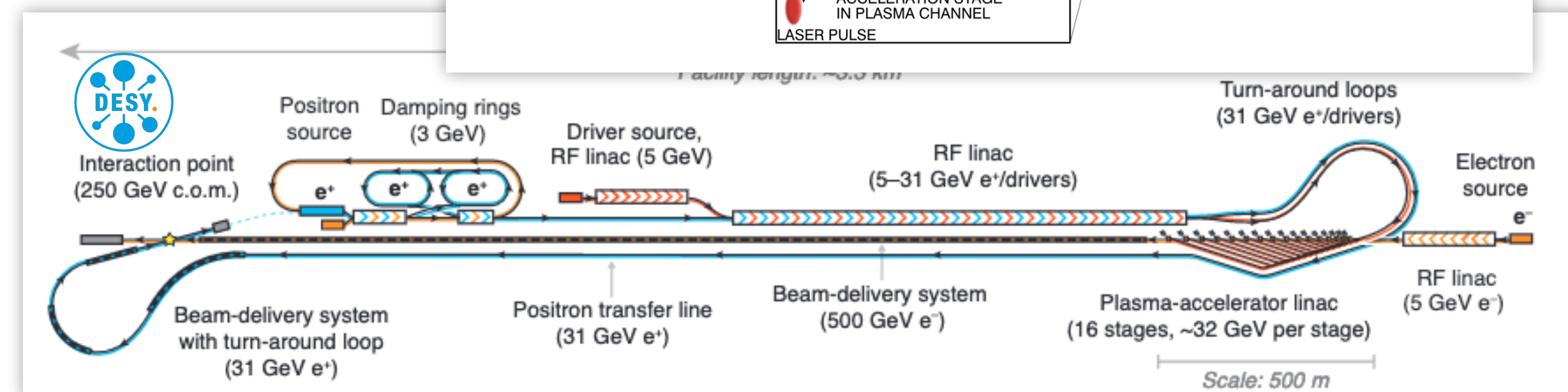
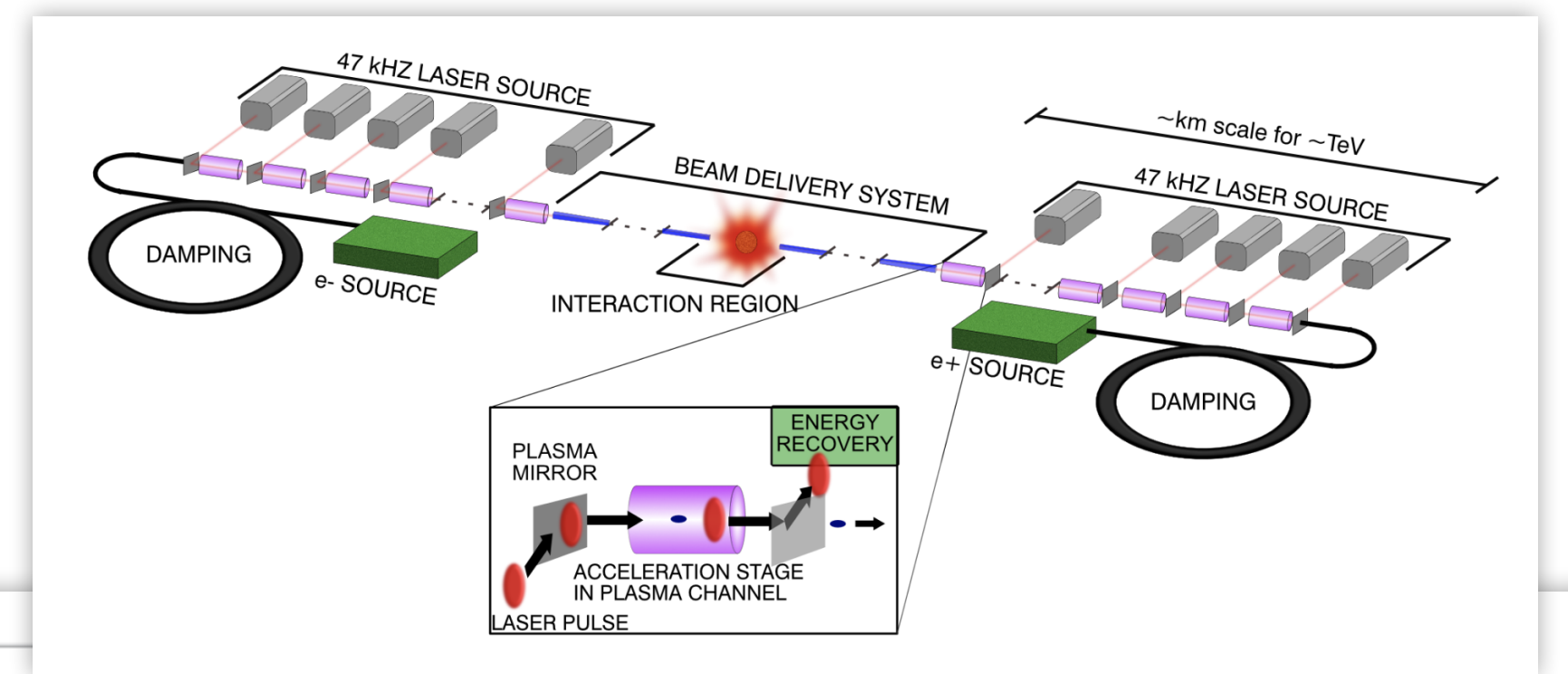
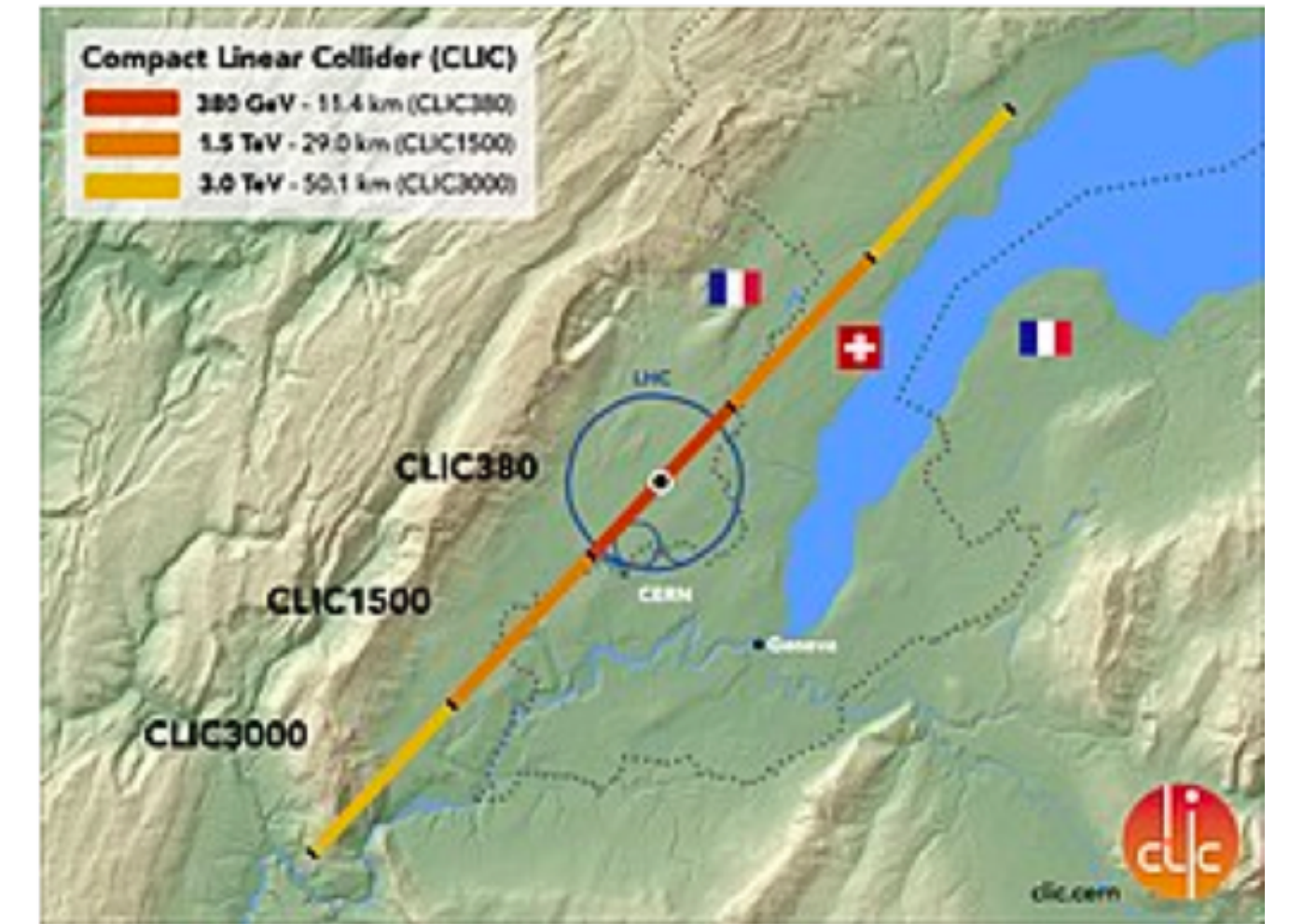

# Linac Proposals or Technologies for Future Upgrades?

ILC  
250/  
500  
GeV

THE TOHOKU REGION OF JAPAN

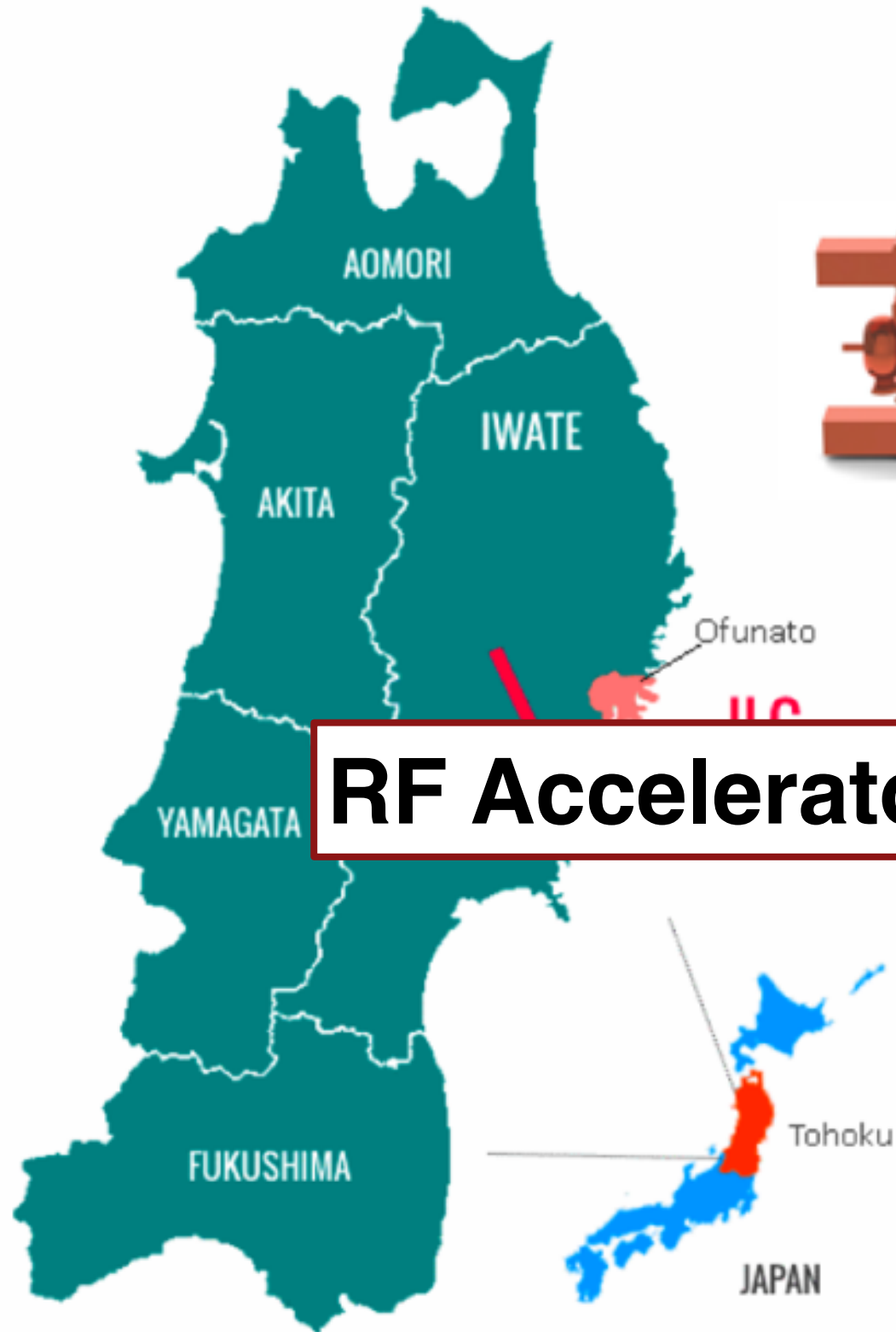

**C<sup>3</sup>** 250/550 GeV  
... > TeV

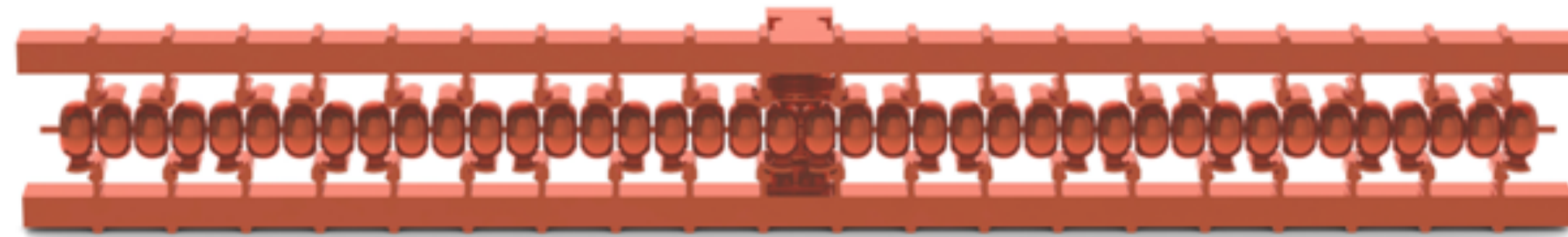

XCC s-channel  $\gamma\gamma \rightarrow H$  @  $\sqrt{s} = 125$  GeV

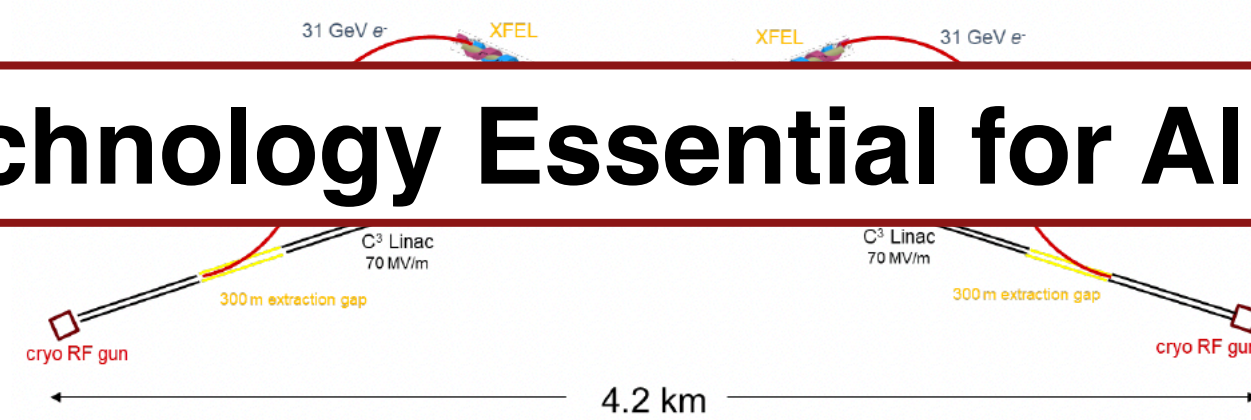

Recirculating  
Linacs

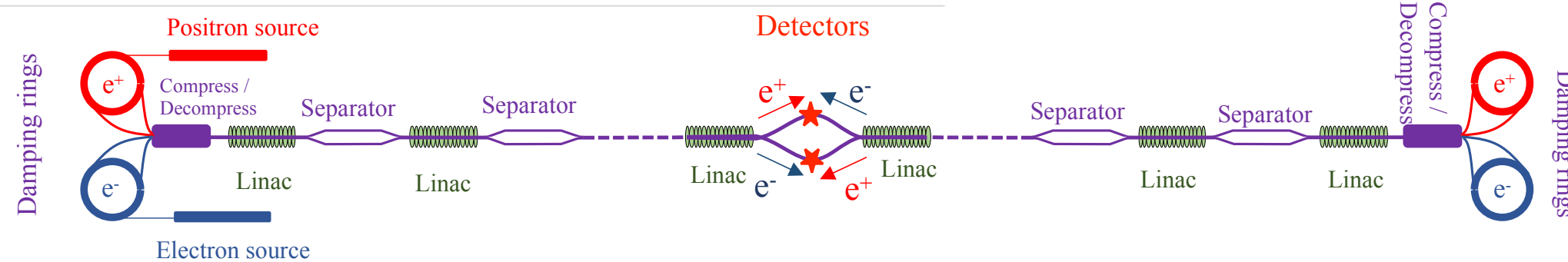

CLIC 380/1000/3000 GeV

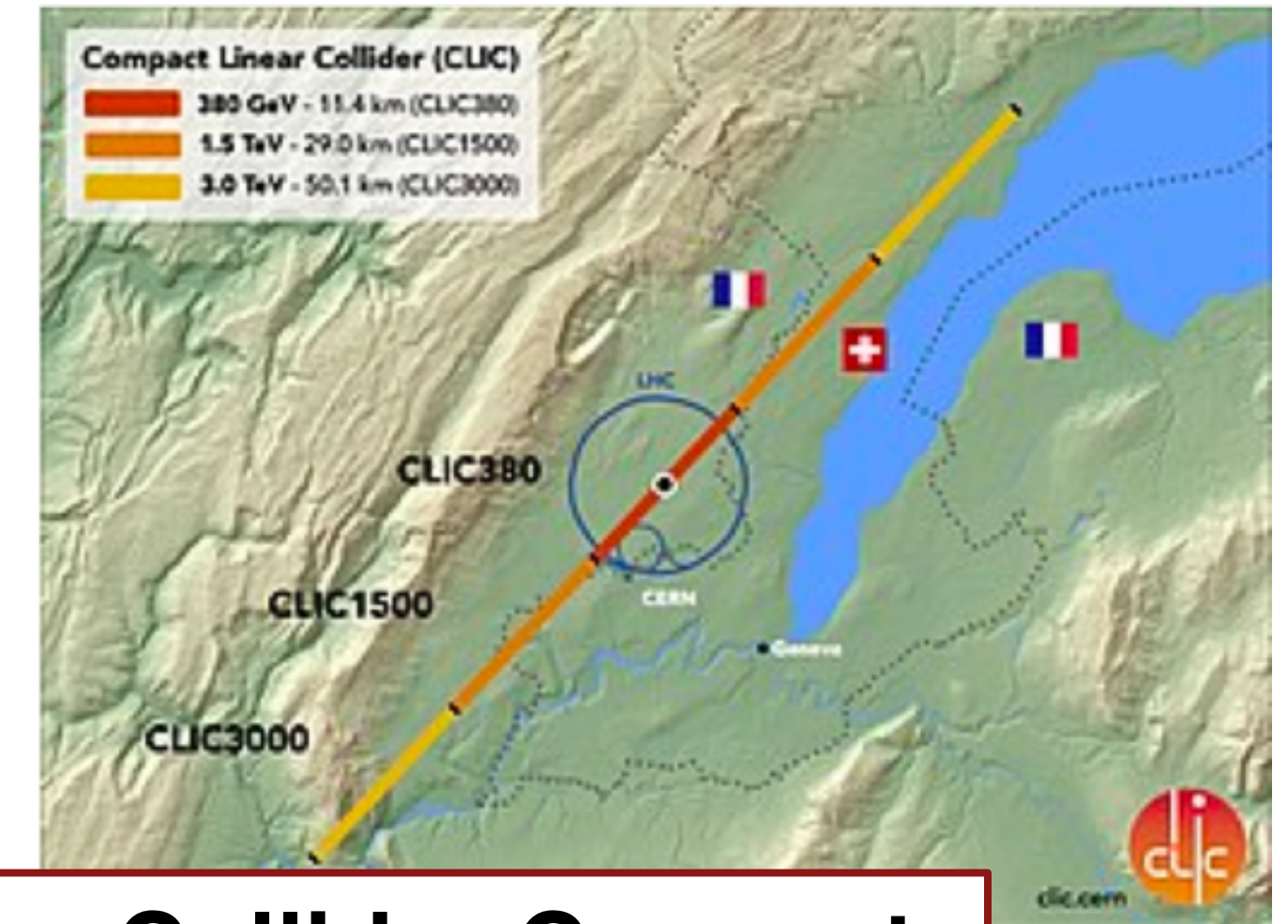

**RF Accelerator Technology Essential for All Near-Term Collider Concepts**

Wakefield  
Accelerators

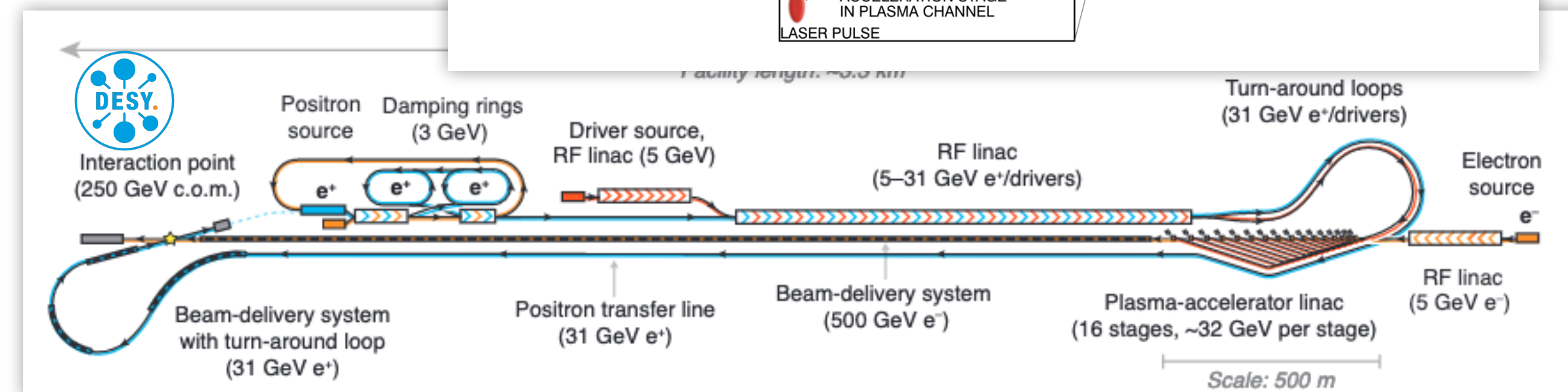
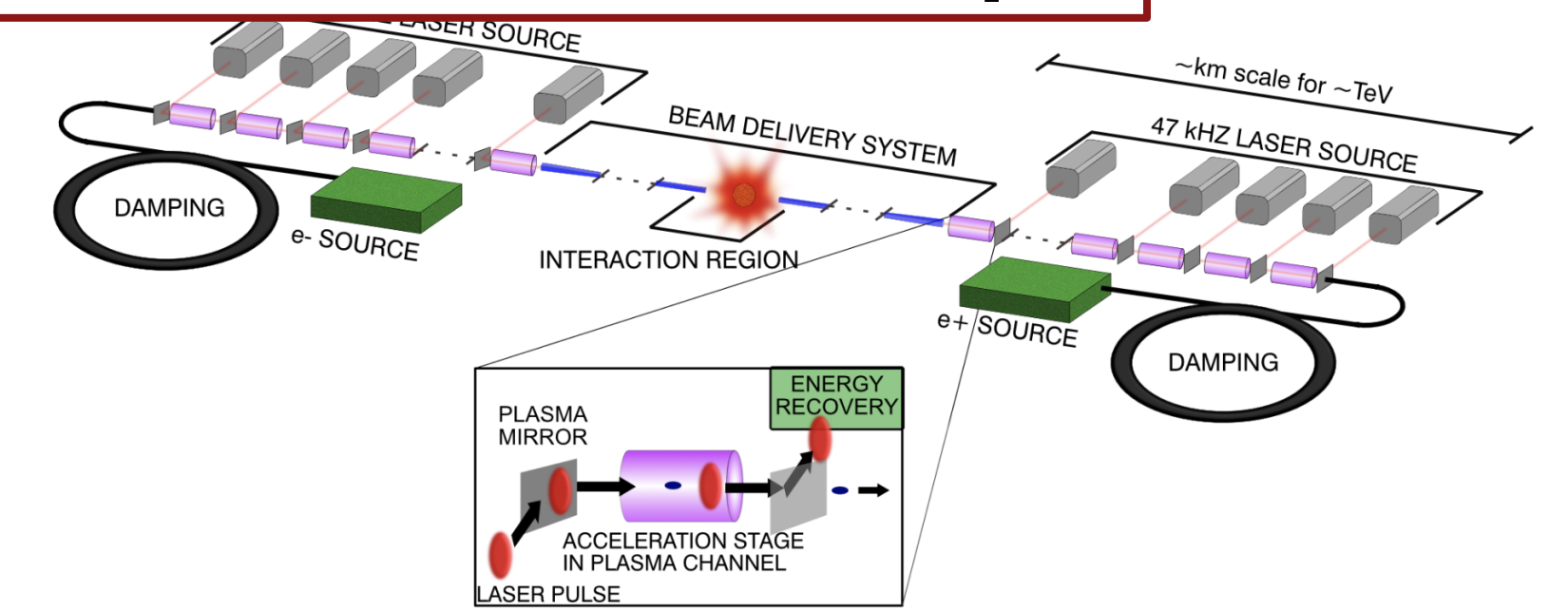

# Synergies with Future HF

C<sup>3</sup> Demo is positioned to contribute synergistically or directly to all near-term collider concepts

- FCC-ee - common electron and positron injector linac from 6 to 20 GeV
  - **reduce length 3.5X OR reduce rf power 3.5X**
- C<sup>3</sup> cryomodule could yield to significant improvements to size and sustainability of FCC-ee high energy linac

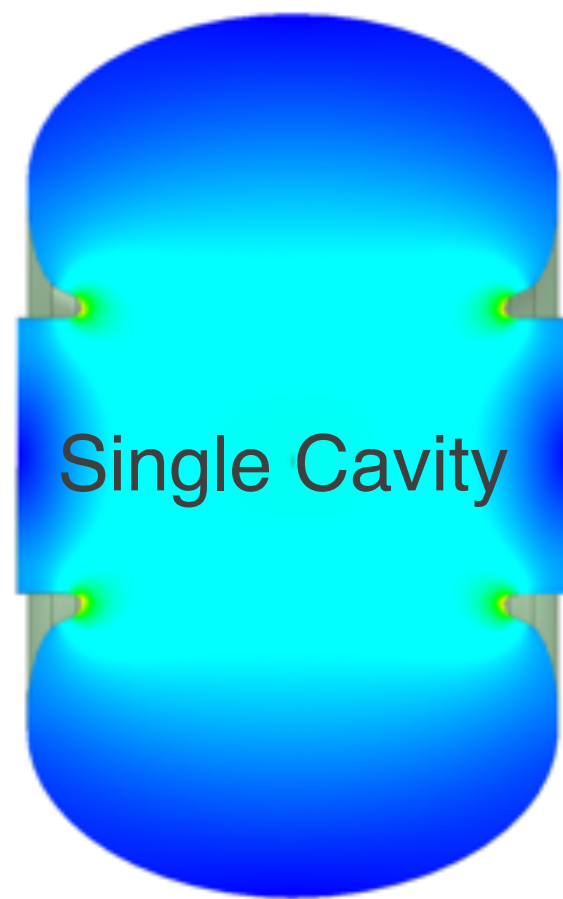
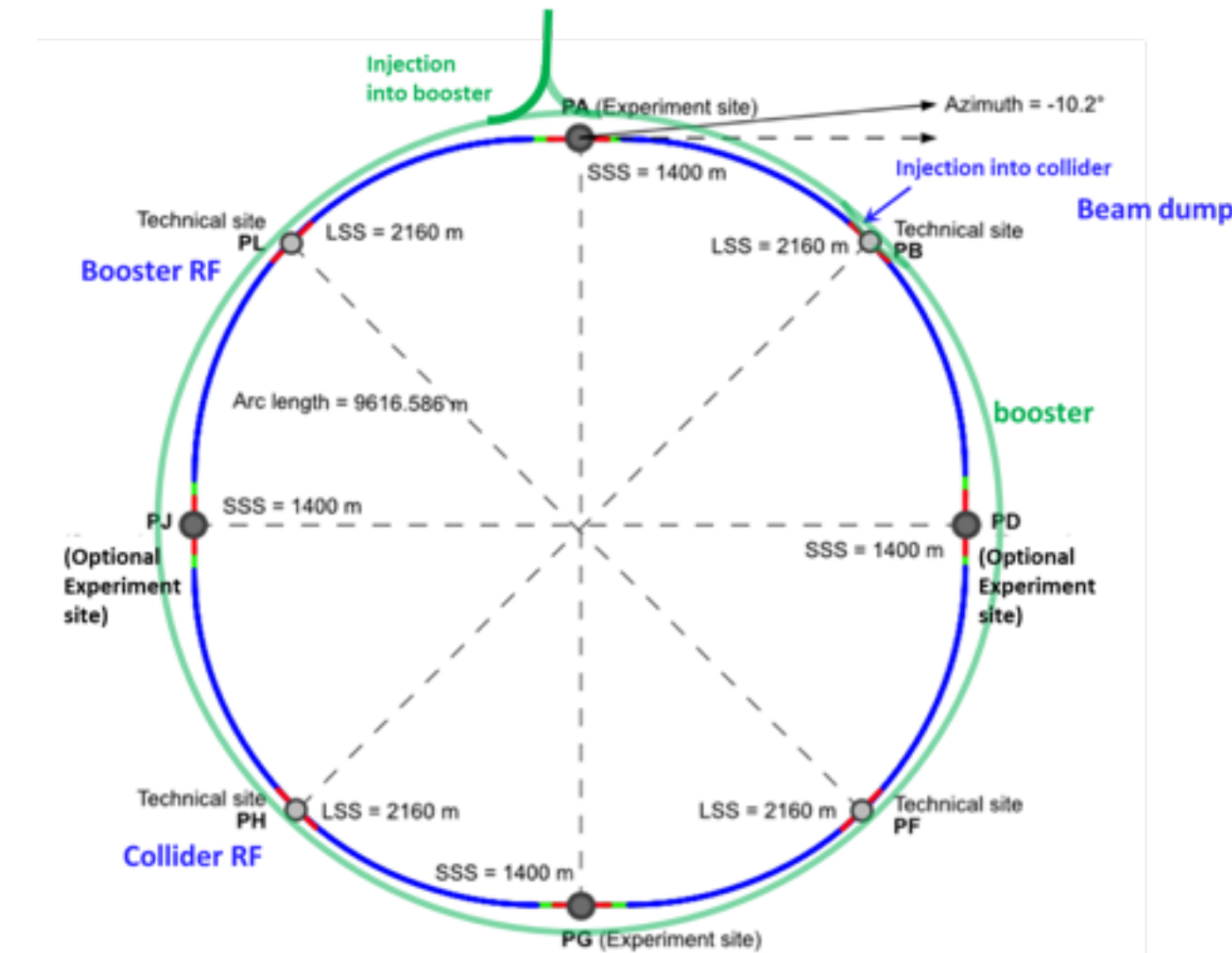

## Design Study: FCC HE-Linac

- Goal is high RF efficiency for a set gradient
- Shunt impedance at 300 K: 58.5 MΩ/m
  - At 77 K: 152 MΩ/m
- Gradient: 22.5 MeV/m
- Baseline design: 6 MW/m, 3 μs
- Pulse compressed version should be even more efficient in terms of RF power

## HE-Linac Requirements

Charge (nC)	0-5.5 nC
Number Bunches	min. 4
Bunch Spacing	25 ns spacing
Initial Energy	6 GeV
Final Energy	20 GeV

# Beam Dynamics Studies for FCC HE Linac

Studies needed to guide accelerator design and alignment tolerances with novel structures

- Single bunch studies used for studying alignment tolerances
- Similar studies were done for FCC HE-Linac design study to determine applicability
  - Large aperture and lower frequency make this design extremely robust

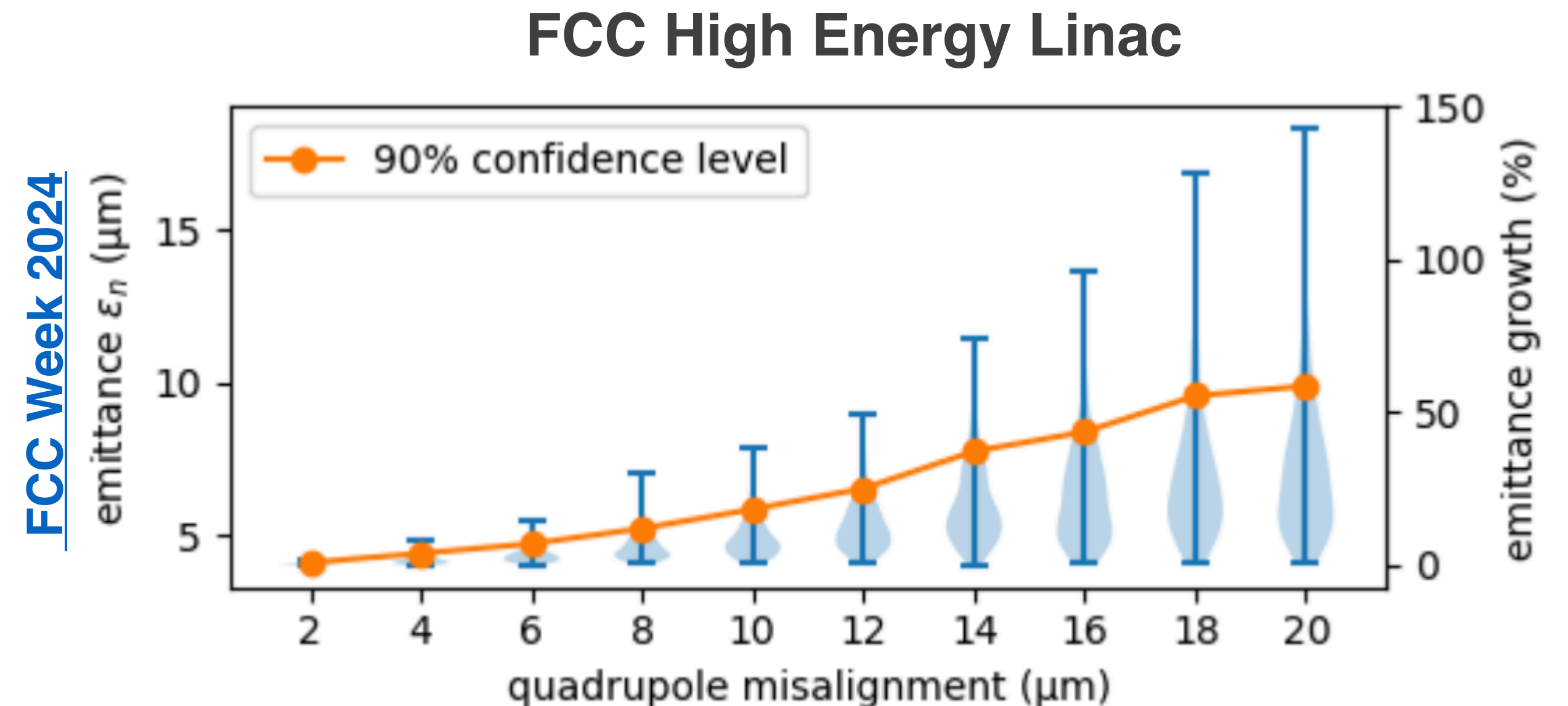
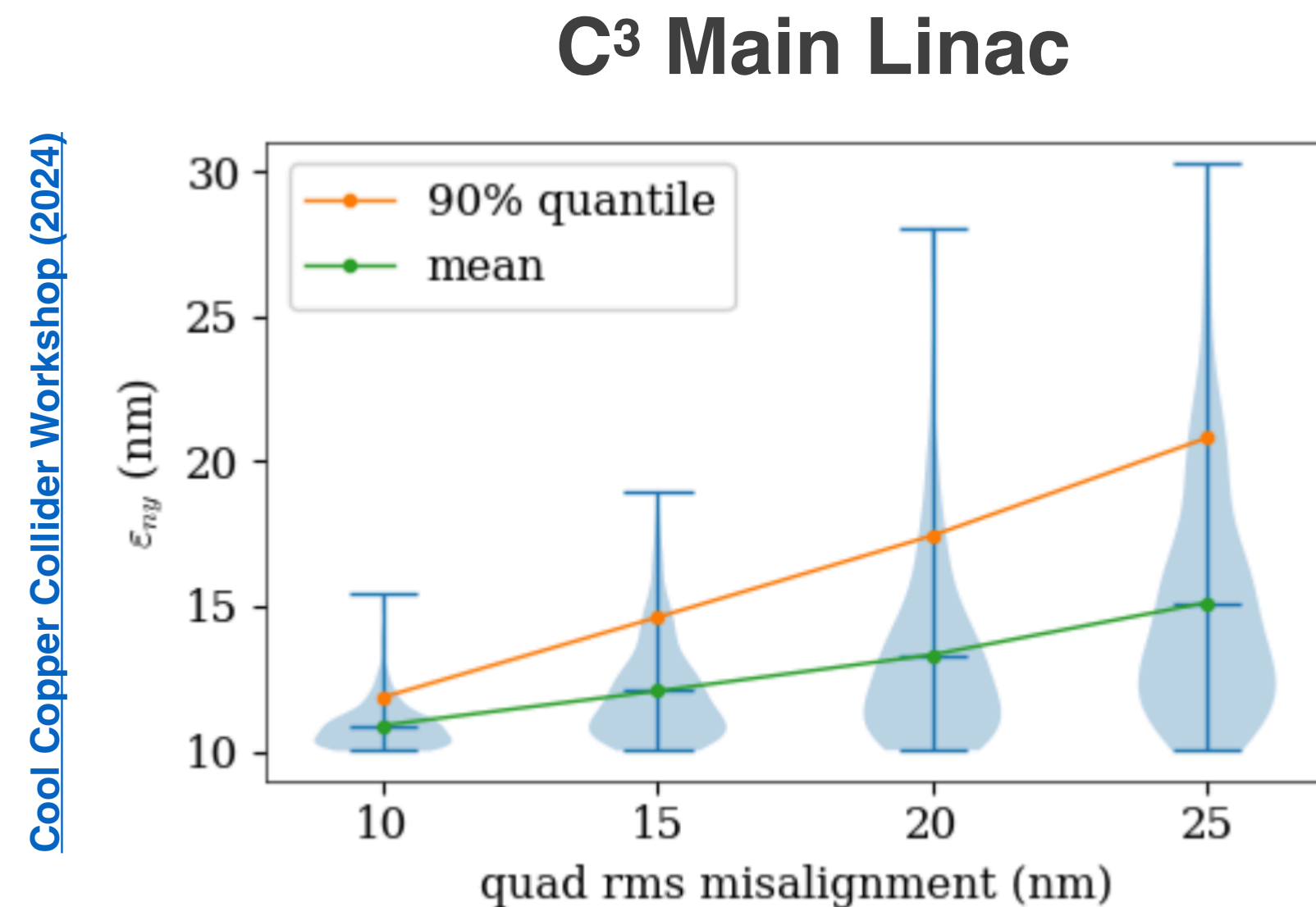

**Distributed coupling structures can maintain emittance to strictest tolerances required for HEP facilities**

# Pathways to Higher Energy

- ILC - options for electron driven positron source based C<sup>3</sup> technology and high energy upgrades
- Assuming ILC 0.25 TeV – 20.5 km
- (2X 7.4 km for linac)

## 0.5 – 1 TeV

→ SRF Materials and SRF Design

## 1 - 2 TeV

→ Cold Copper and NCRF Design

→ Two-Beam Accelerators

## O(10) TeV

→ Wakefield Accelerators

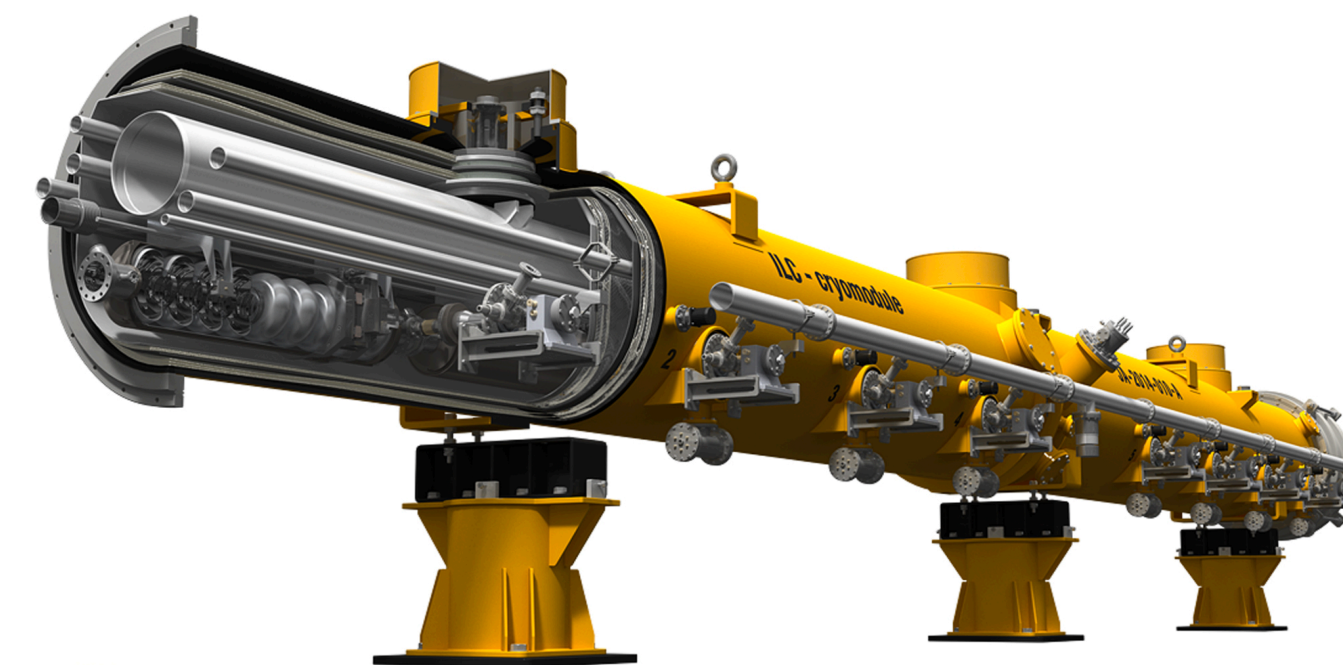
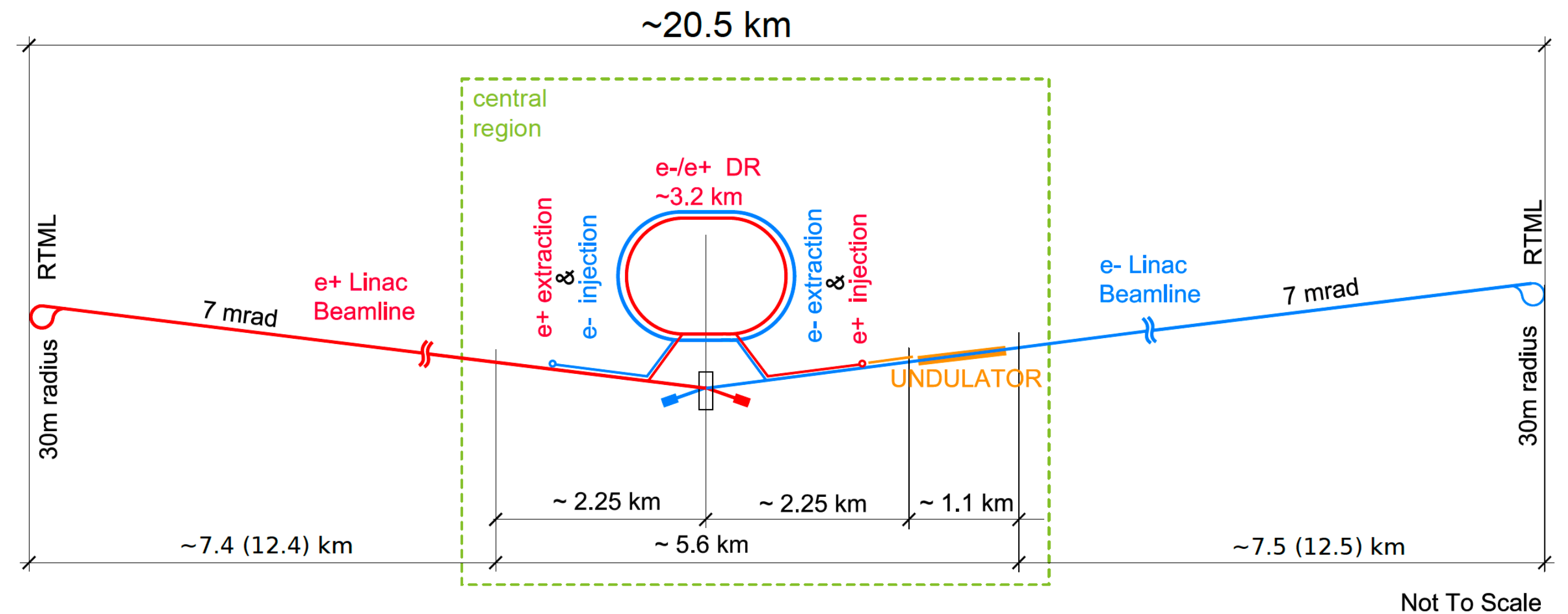

DESY-22-045, "The international linear collider: Report to snowmass 2021"



# Energy Upgrade of ILC 250 - C<sup>3</sup>-1TeV

- Cryoplants replaced or modified
- Injectors and damping rings reusable with fast kickers and extraction of bunch trains
- Sustainability: Adoption of lower repetition rate, higher beam loading will improve power consumption

Parameter	Unit	Value	Value
Center of Mass Energy	GeV	1000	2000
Site Length	km	20	20
Main Linac Length (per side)	km	7.5	7
Accel. Grad.	MeV/m	75	155
Flat-Top Pulse Length	ns	500	195
Cryogenic Load at 77 K	MW	14	20
Est. AC Power for RF Sources	MW	68	65
Est. Electrical Power for Cryogenic Cooling	MW	81	116
RF Pulse Compression		N/A	3X
RF Source efficiency (AC line to linac)	%	50	80
Luminosity	$\times 10^{34} \text{ cm}^{-2} \text{ s}^{-1}$	~4.5	~9
Single Beam Power	MW	13.5	9
Injection Energy Main Linac	GeV	10	10
Train Rep. Rate	Hz	60	60
Bunch Charge	nC	1	1
Bunch Spacing	ns	3	1.2

# Hybrid Cold Copper + High Temp Superconductors (HTS)

Exploratory research to develop the basis for a HTS based RF cavity for pulse compression

Using the same cryostat that kicked off cold copper work, high power RF testing of HTS samples is underway

- Samples are deposited on copper and MgO as well as HTS tapes or compressed pucks
- **HTS coated cavities can function in strong magnetic fields, potential candidate for muon cooling cavities**
- Estimated  $Q_0$  for HTS cavity using the TM010 mode at 77 K is 150,000 (versus 22,500 for copper)

Cryostat



HTS Sample

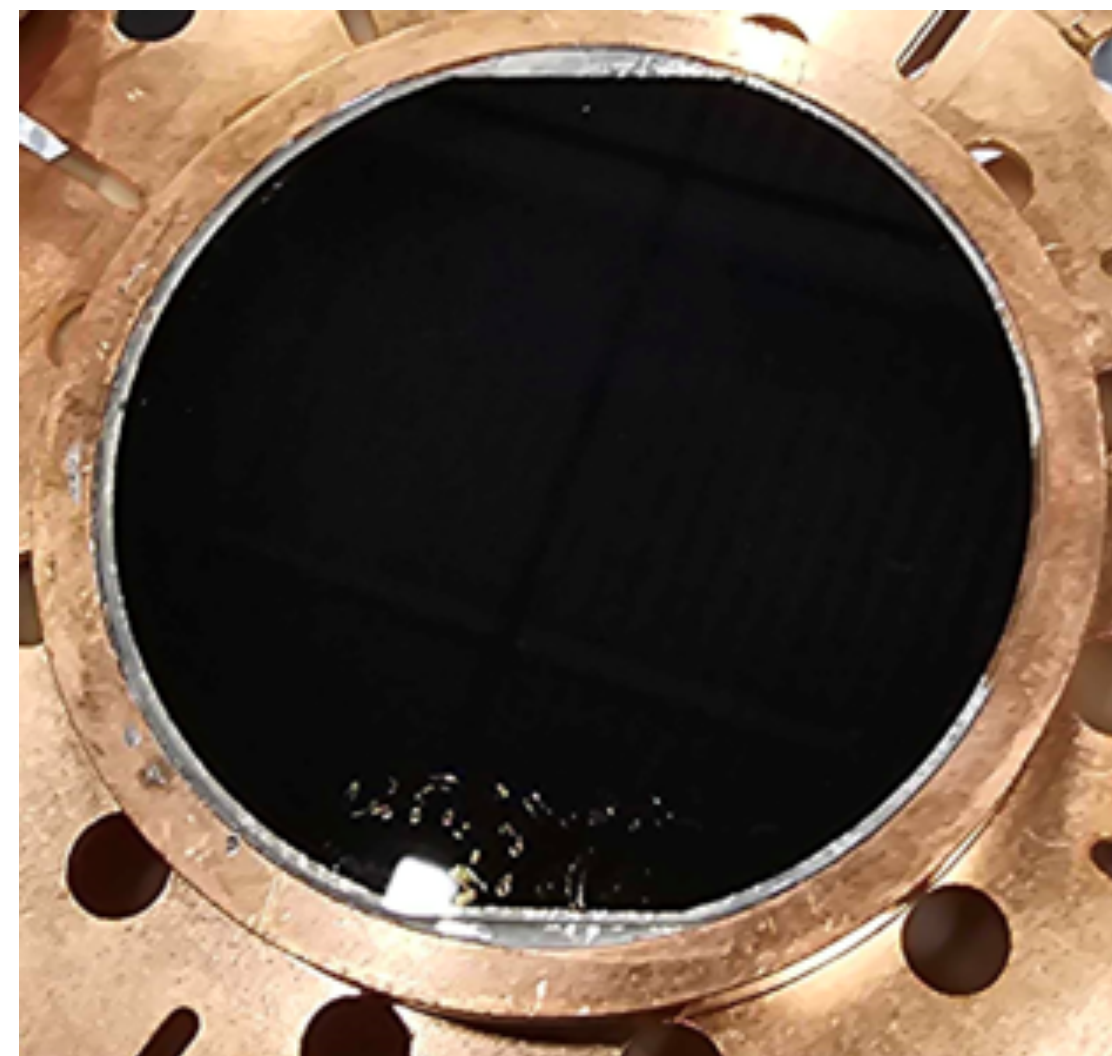

Sample Conductivity with High Power

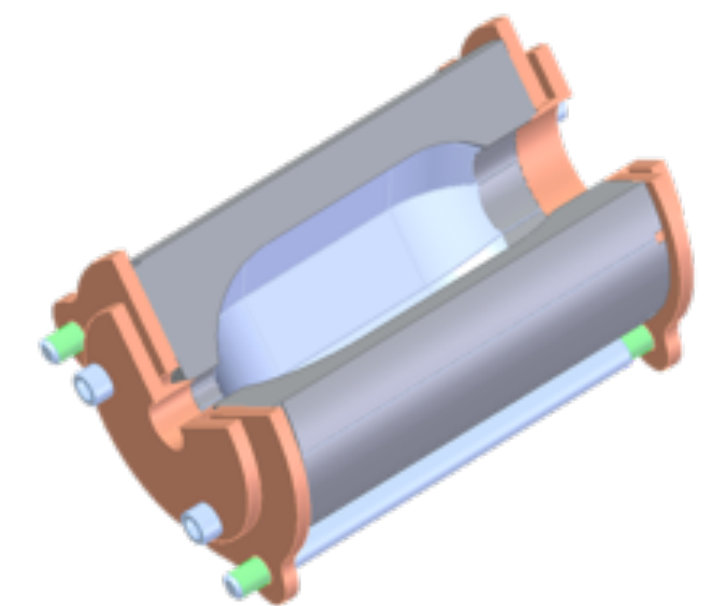
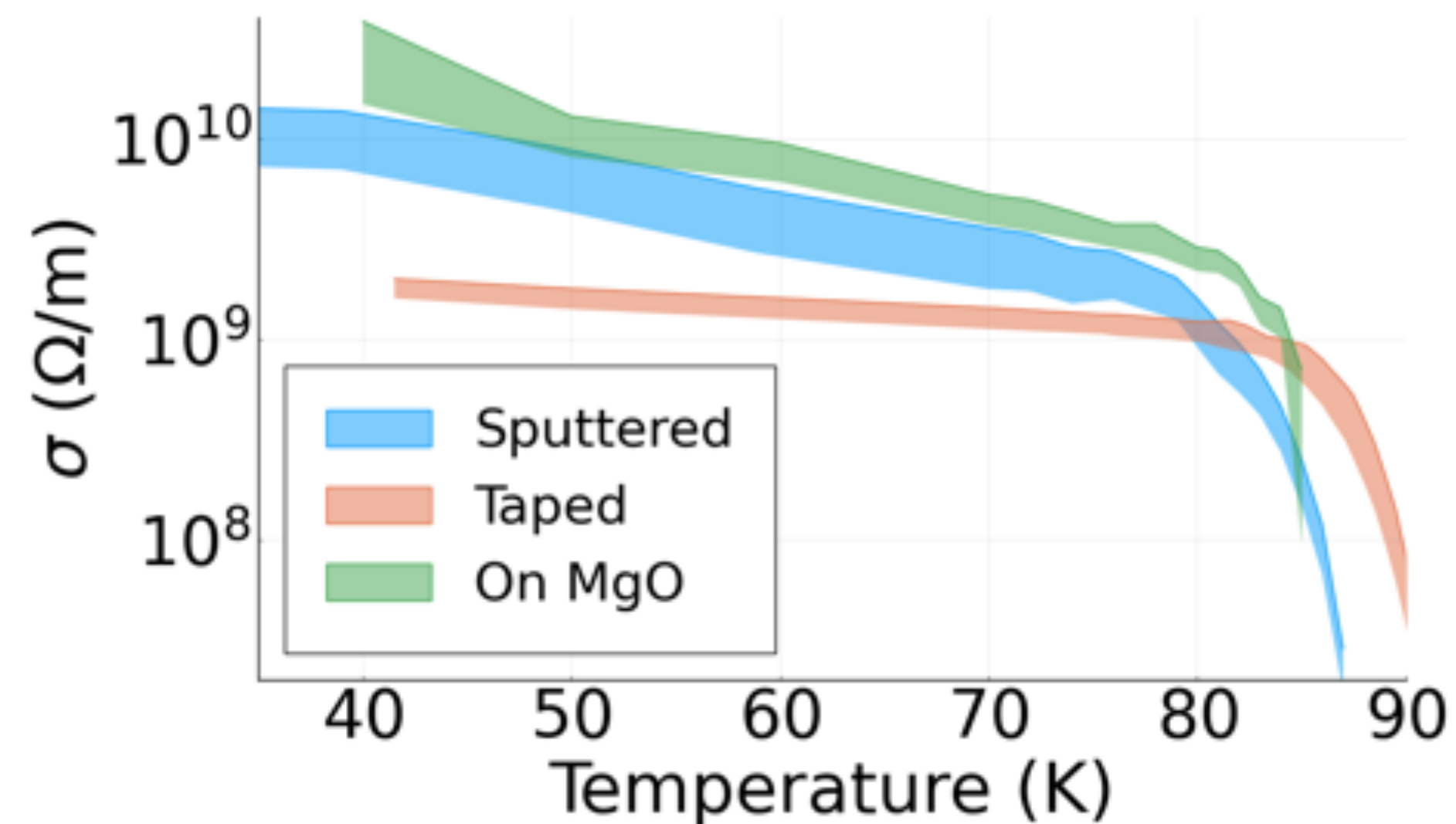

Prototype HTS Cavity



[IPAC2024 p. WEPS37](#)

**HTS materials represent a new regime of SRF applications**

# C<sup>3</sup> for the Muon Collider

Cooling channel requires high-gradient, significant RF power and low rep rate pulse format

RF accelerator technology requires normal conducting rf due to magnetic fields (7T+) and thermal load from scattering by absorbers

- Cold-copper to reduce rf power requirements and increase gradient
- Distributed coupling to optimize rf distribution and remove cell-to-cell coupling
- Need to understand scaling with frequency – synergy to develop cold copper test stands

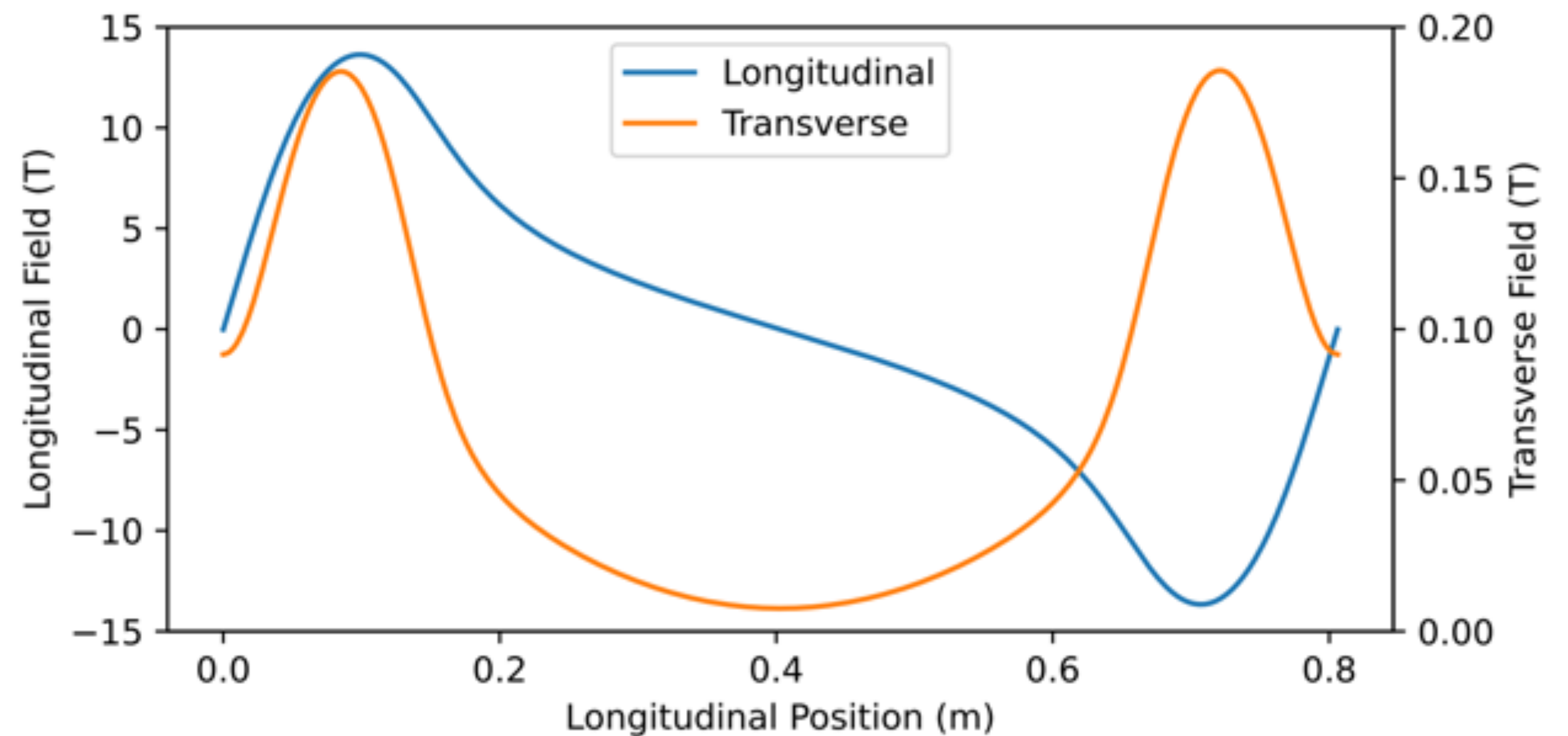
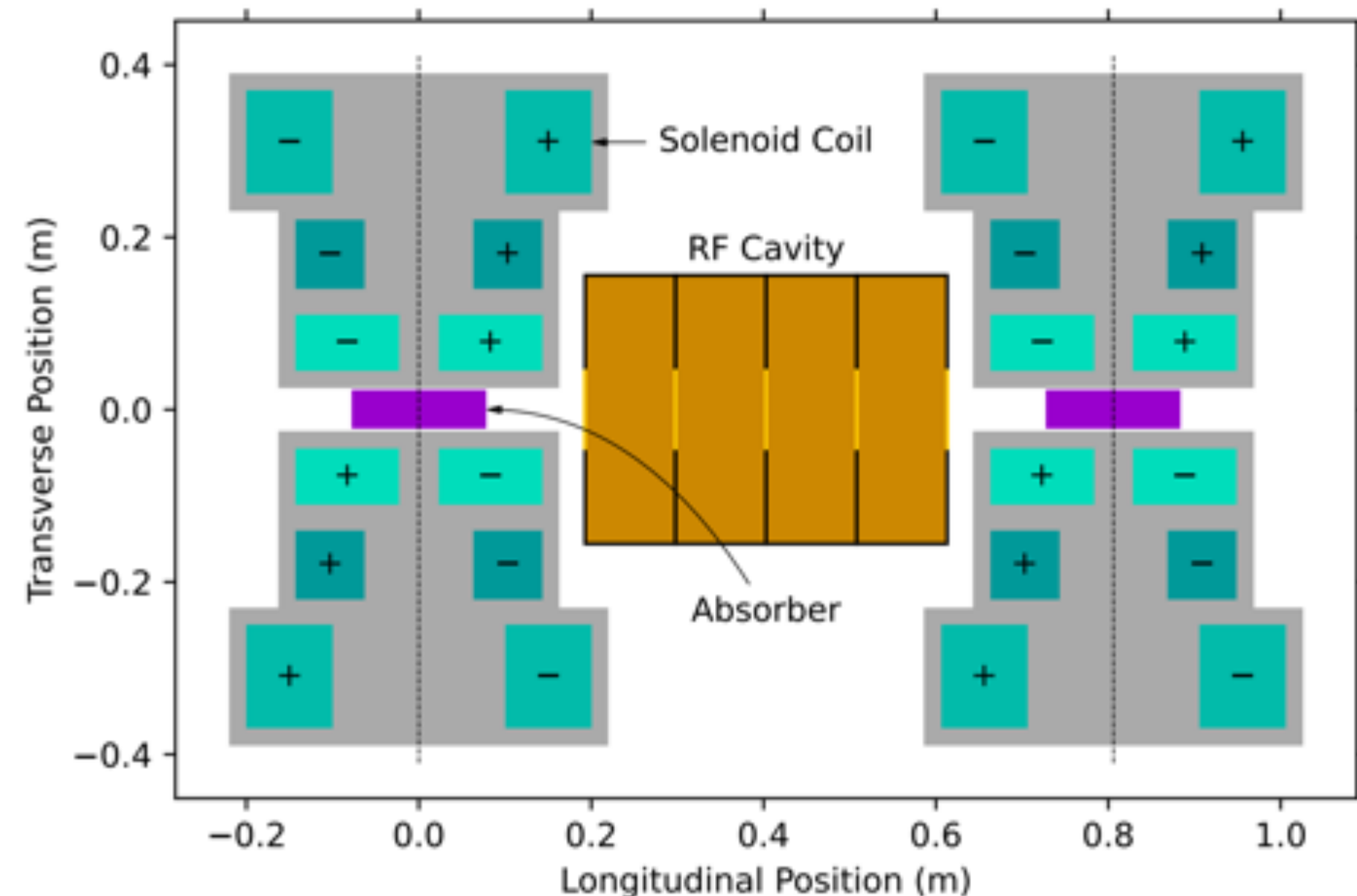

doi: 10.18429/JACoW-IPAC2024-WEPR34

# The Path to 10+ TeV

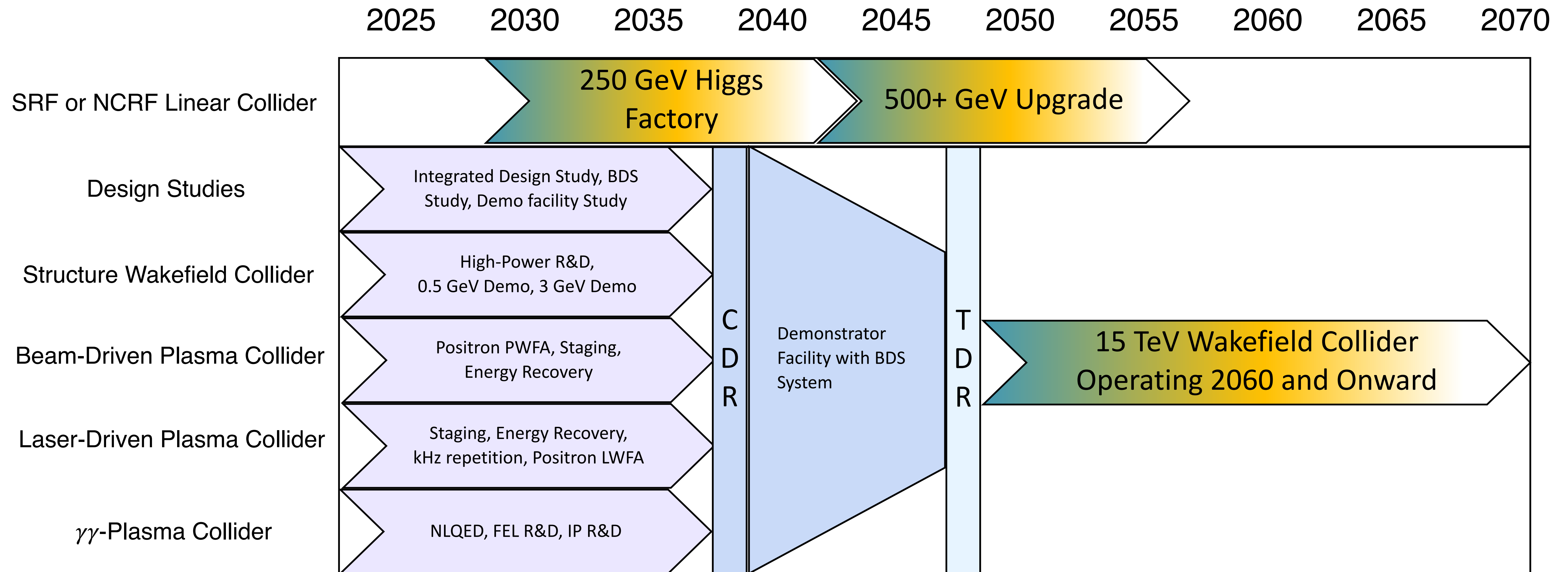

Wakefield Accelerators can be developed in parallel with the operation of Linear Collider Higgs Factories to provide a staged upgrade path to the energy frontier.

ACC Sessions at LCWS 2024 <https://agenda.linearcollider.org/event/10134/sessions/5585/#20240709>

# Distributed-Coupling based Large Aperture Injector Linac

S-Band linac developed for efficient acceleration of high charge bunches

- Current design (based on EIC) would preserve emittance for up to 14 nC bunches with 18 MV/m gradient
  - Power draw would only be 5 MW for a meter-long 20 cavity linac
  - Large aperture design (14.12 mm) for reduced wakefields
- Operating cold enables even higher gradients/RF efficiency
  - Up to 80 MV/m with 35 MW per structure
  - High-gradient and rf-to-beam efficiency for HALHF positrons

Prototype Linac

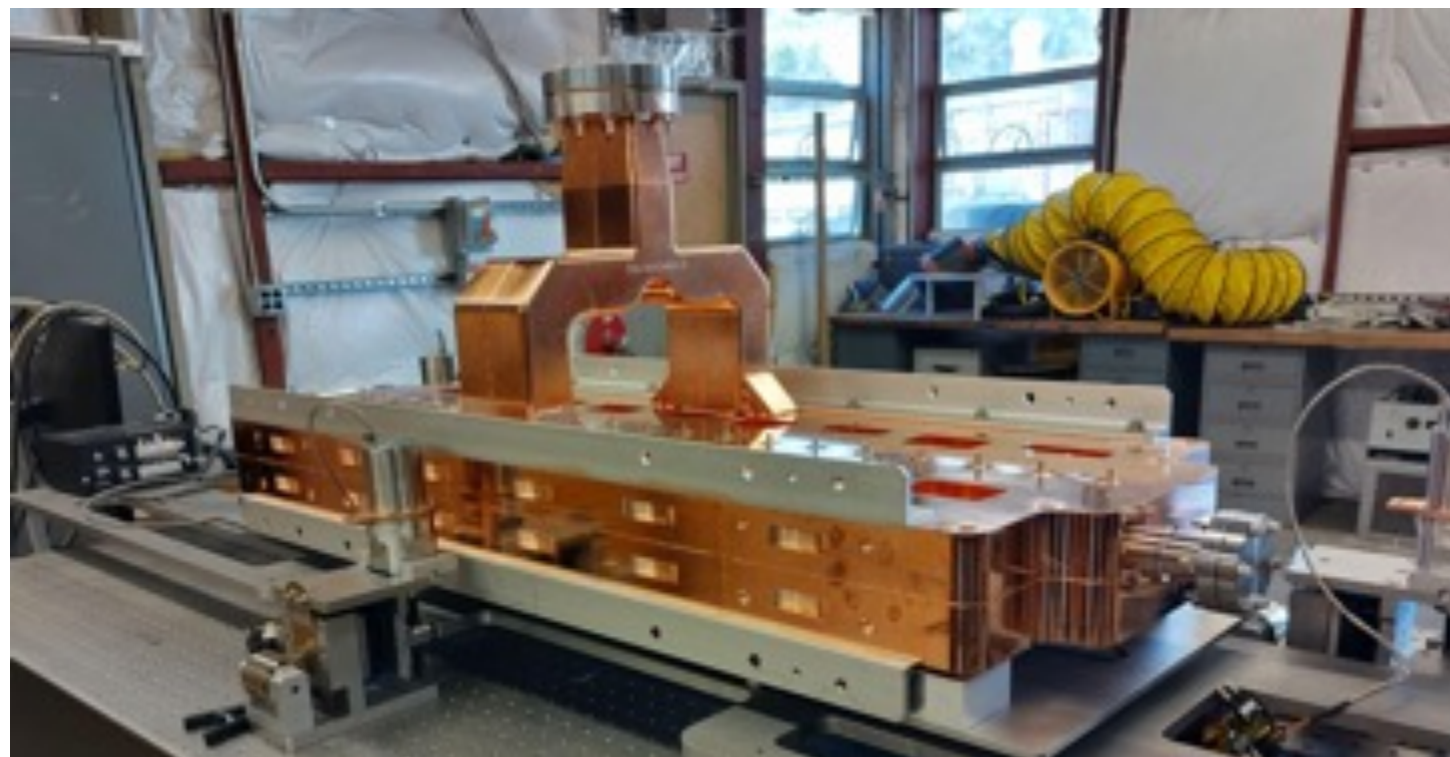

HALHF Concept  
Positron 3 GeV Linac

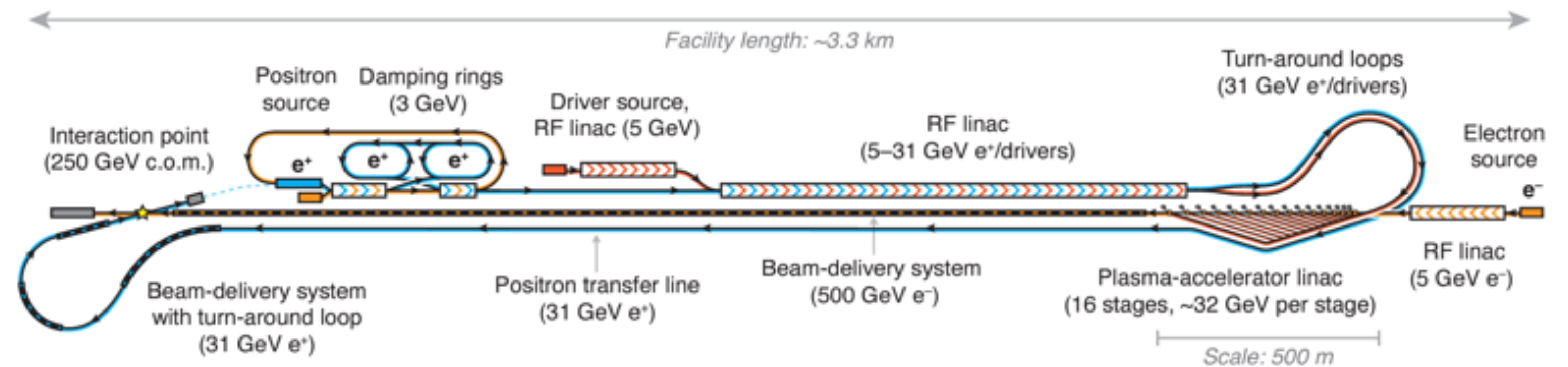

# Outlook

---

- C<sup>3</sup> Demo is positioned to contribute synergistically or directly to all near-term collider concepts
- Distributed coupling and cold copper technology can be applied to injector linacs and other high beam power applications, e.g. HALHF Positron Linac
  - ILC 250 GeV with 20 km footprint can reach 2 TeV with C<sup>3</sup> technology
  - C<sup>3</sup> cryomodule could yield to significant improvements to size and sustainability of FCC-ee high energy linac
- Muon Collider - high gradient cryogenic copper cavities in cooling channel, alternative linac for acceleration after cooling
- AAC - C<sup>3</sup> Demo utilized for staging, C<sup>3</sup> facility multi-TeV energy upgrade reutilizing tunnel,  $\gamma\gamma$  colliders
- Vigorous Accelerator R&D needed to unlock this potential

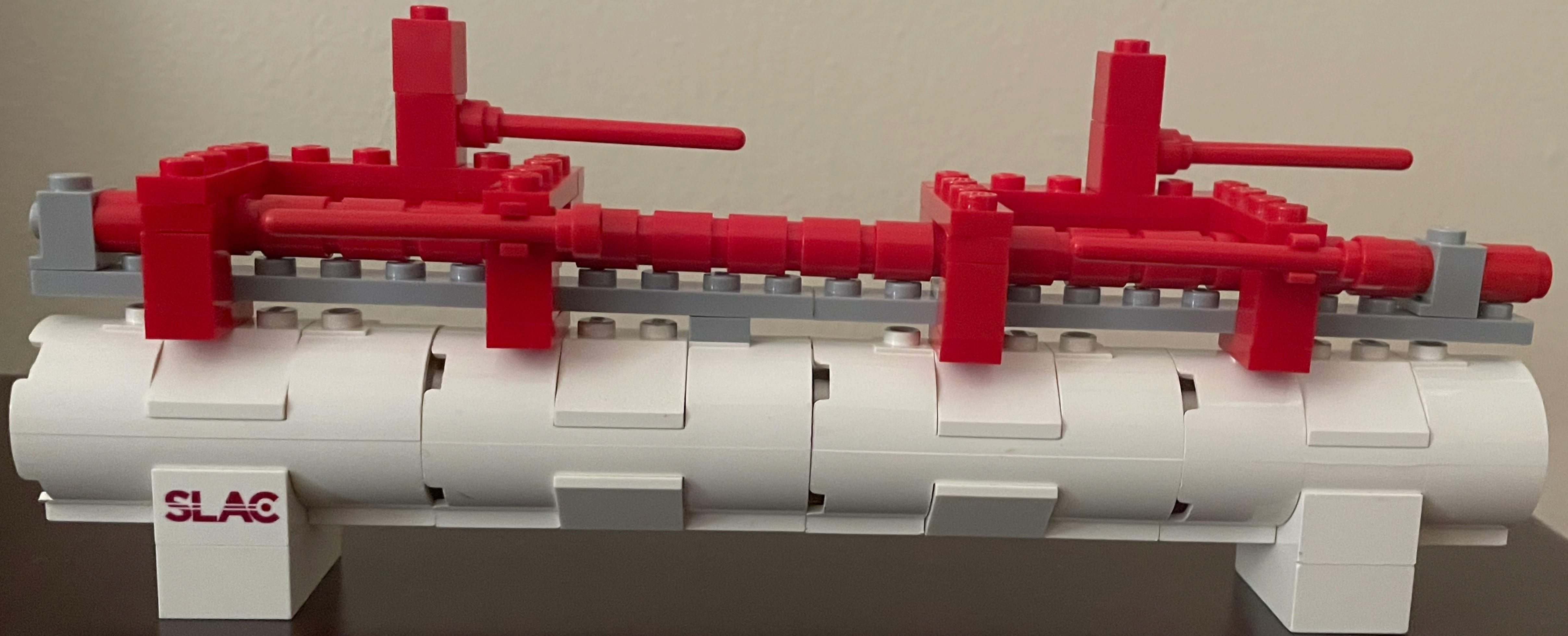

*thank you!*

# C<sup>3</sup> Acknowledgements

WEBSITE [web.slac.stanford.edu/c3/](http://web.slac.stanford.edu/c3/)

SLAC-PUB-17661  
April 12, 2022  
Strategy for Understanding the Higgs Physics:  
The Cool Copper Collider

*Jinst* PUBLISHED BY IOP PUBLISHING FOR SISSA MEDIALAB  
RECEIVED: June 2, 2023  
ACCEPTED: August 23, 2023  
PUBLISHED: September 28, 2023  
SNOWMASS'2021 ACCELERATOR FRONTIER  
Status and future plans for C<sup>3</sup> R&D

SLAC-PUB-17629  
November 1, 2021  
C<sup>3</sup> : A “Cool” Route to the Higgs Boson and Beyond

Perspective Open Access  
Sustainability Strategy for the Cool Copper Collider  
Martin Breidenbach, Brendon Bullard, Emilio Alessandro Nanni, Dimitrios Ntounis, and Caterina Vernieri  
PRX Energy 2, 047001 – Published 26 October 2023



**Community Workshops:**  
Virtual, Fermilab, SLAC, LANL &  
Cornell University  
220 Participants 60 Institutions

<https://sites.google.com/view/ec4c3>

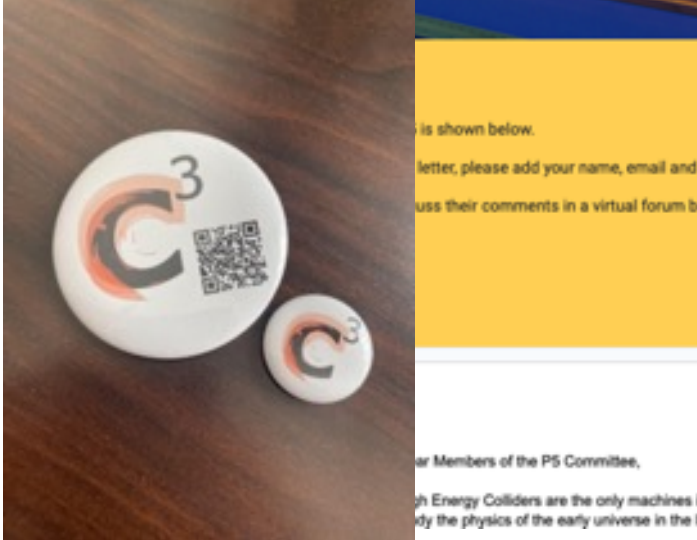
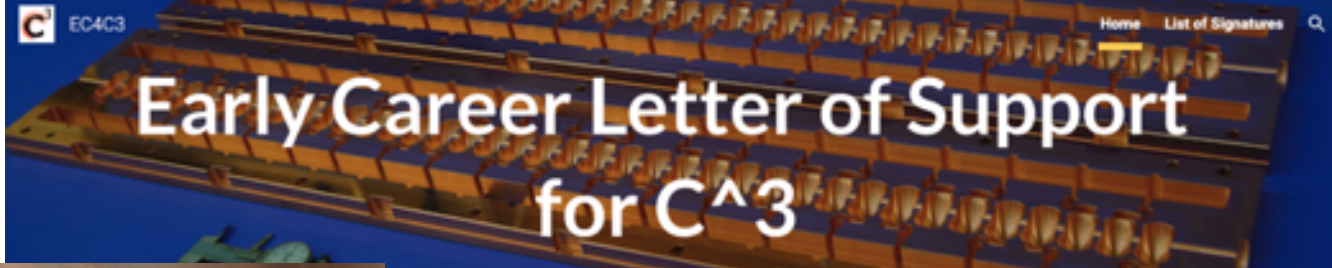

**Next Meeting at LCWS July. 12<sup>th</sup> '24 @ Tokyo Univ.**

# Synergies with Future Colliders

## RF Accelerator Technology Essential for All Near-Term Collider Concepts

- Planned test at Argonne
- Tracking with Lucretia includes longitudinal and transverse wakes, chromatic effects etc
- Error study is 100 seeds, 100  $\mu\text{m}$  element offsets, 300  $\mu\text{rad}$  element rolls (rms)
  - No corrections applied

### Wide Aperture S-band Injector Linac

$$a/\lambda = 0.125$$



90% seeds < 8  $\mu\text{m-rad}$  with lattice errors

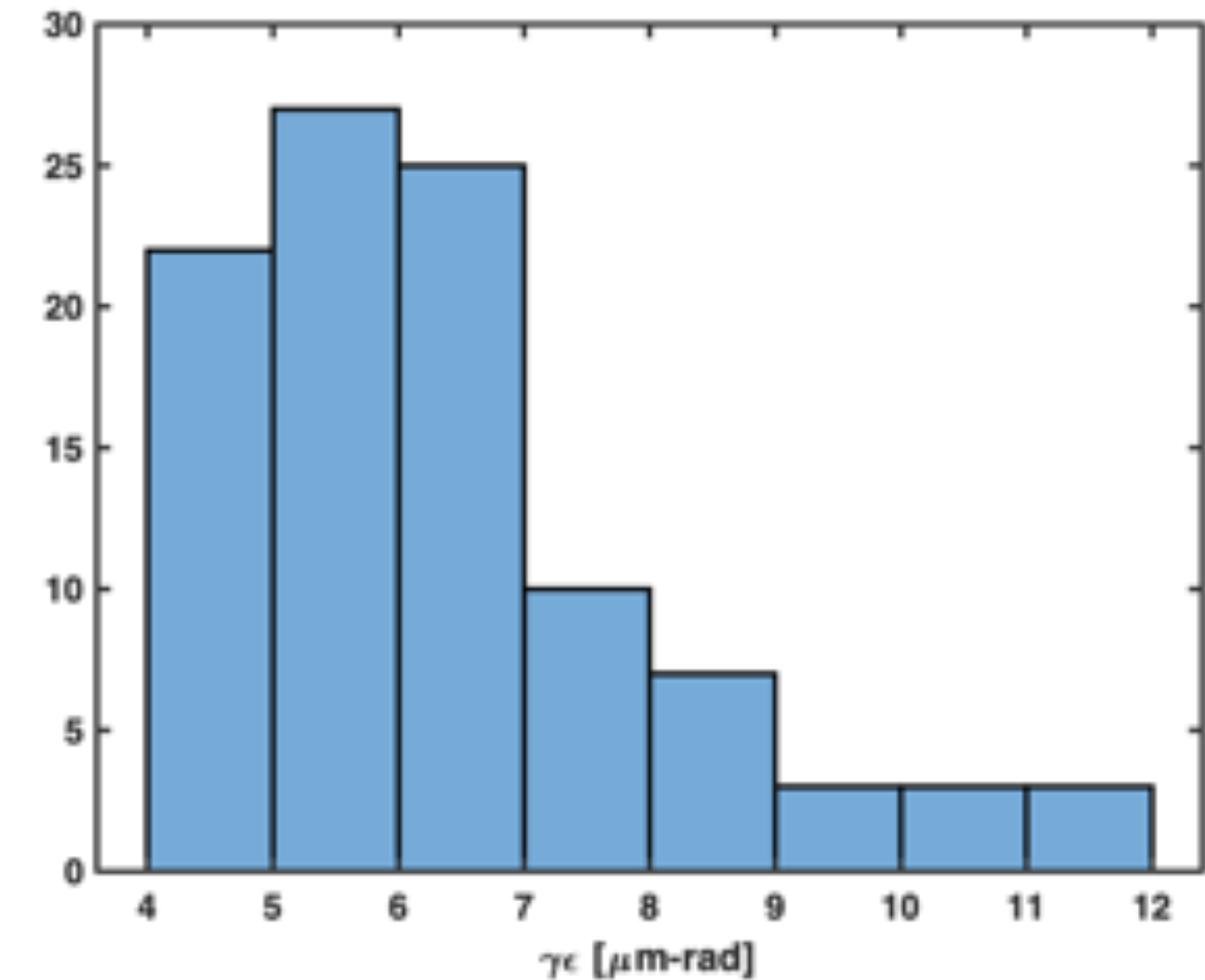
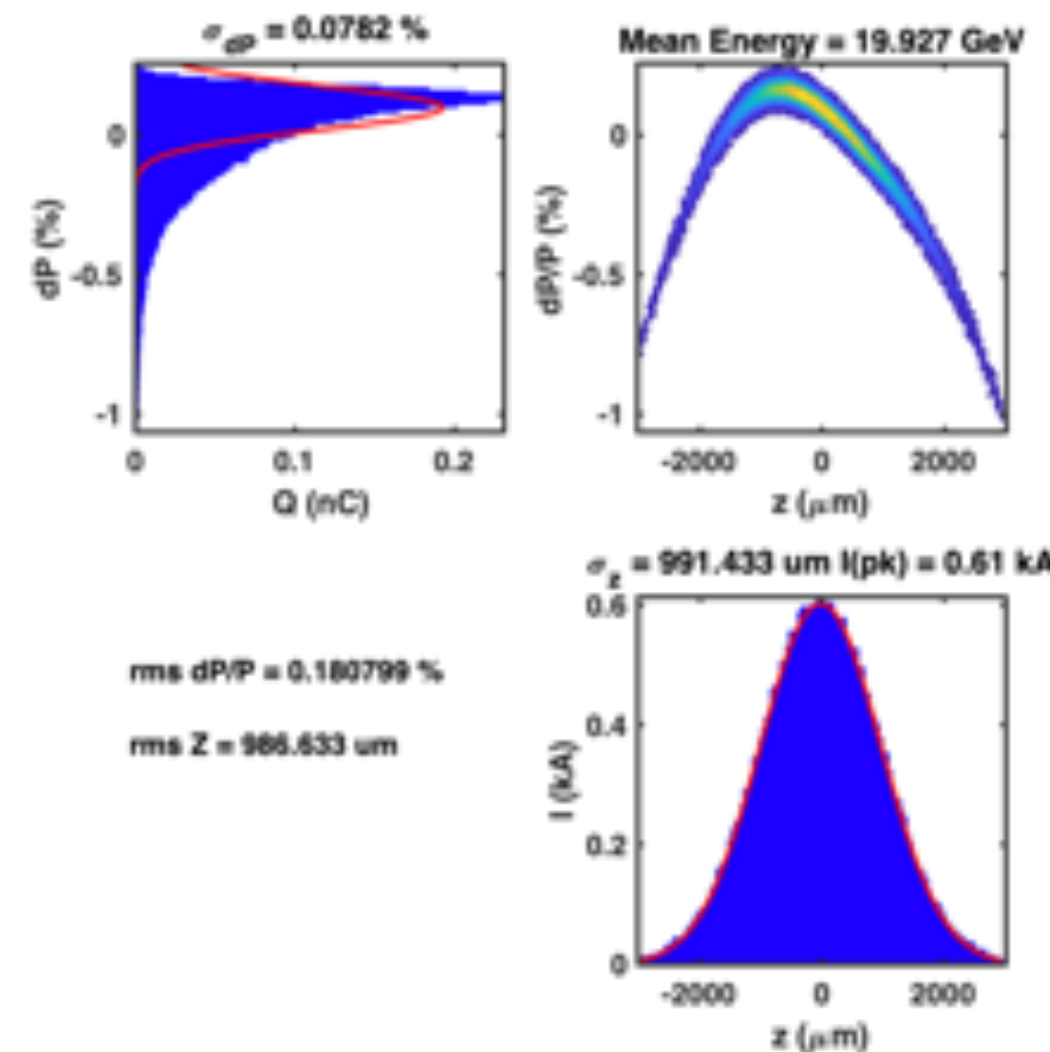

# C<sup>3</sup> Recap: the Cool Copper technology

C<sup>3</sup> is a new linac normal conducting technology

- Distributed power to each cavity from a common RF manifold
  - modern super-computing for solution
  - Seemingly complex structure can easily and inexpensively be built with **modern CNC Machines**
- Cryogenic temperature elevates performance in gradient
  - Operation at 77 K with liquid nitrogen is simple and practical

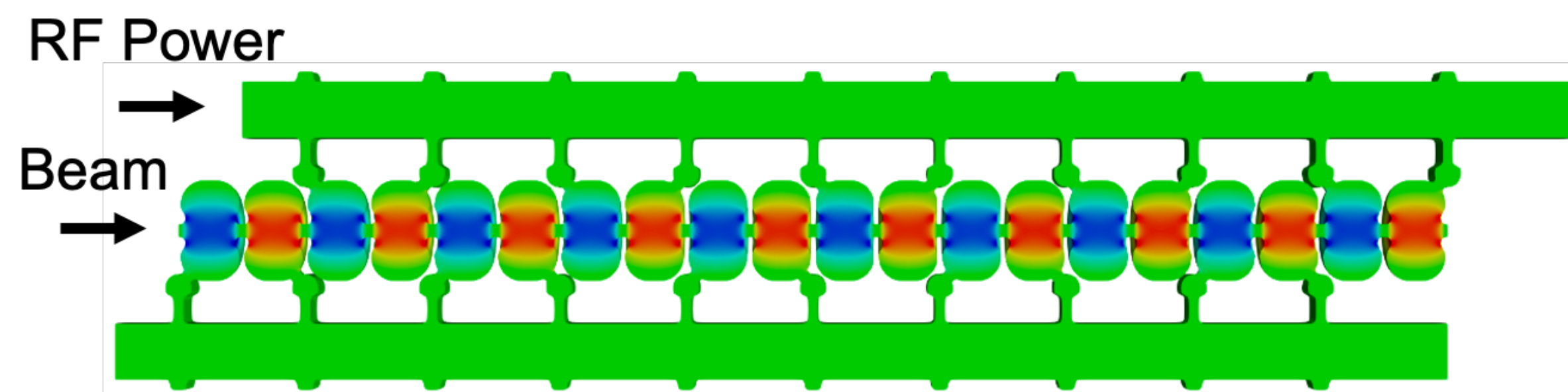

Electric field magnitude for equal power from RF manifold

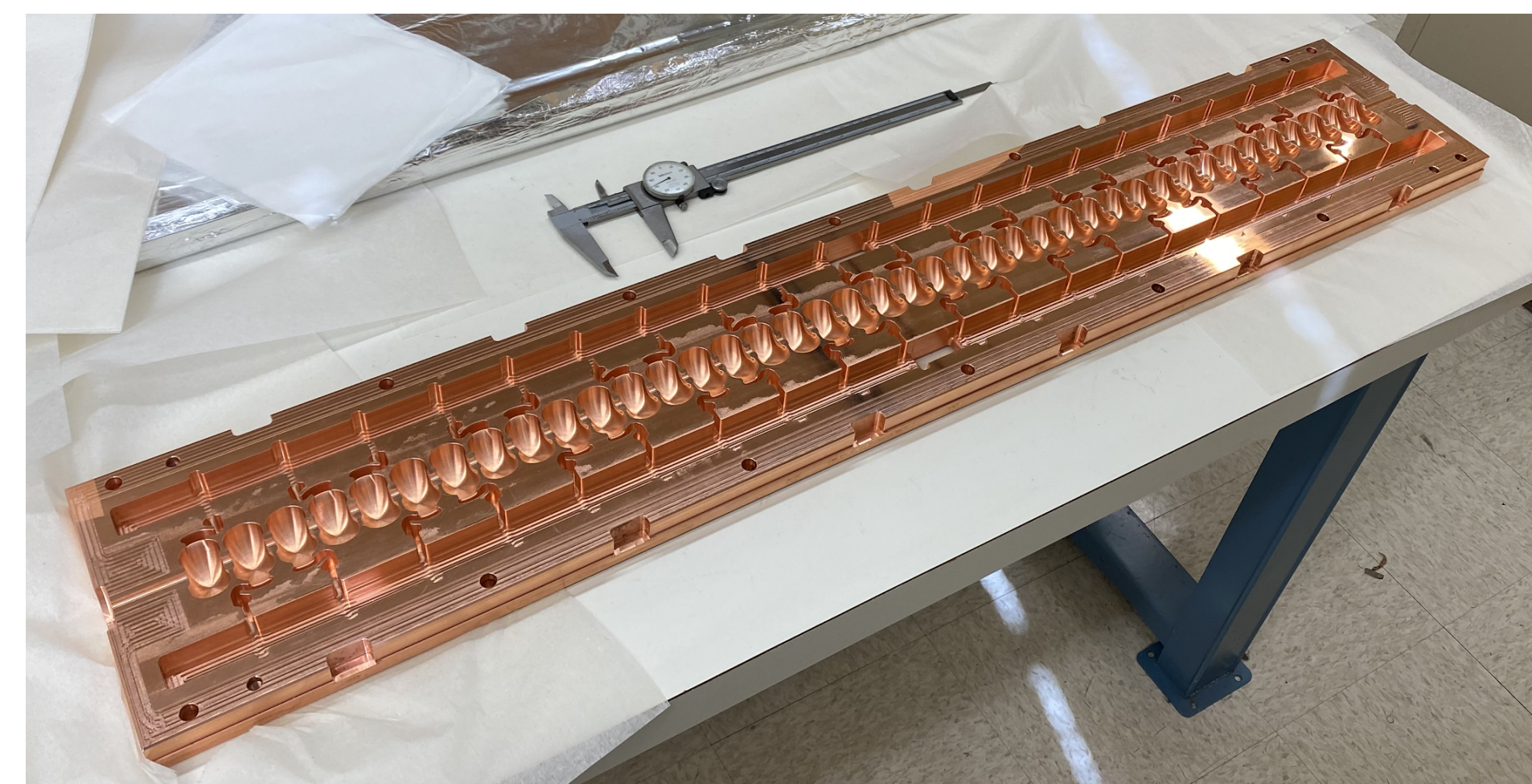

First C<sup>3</sup> structure at SLAC

# C<sup>3</sup> Why cool?

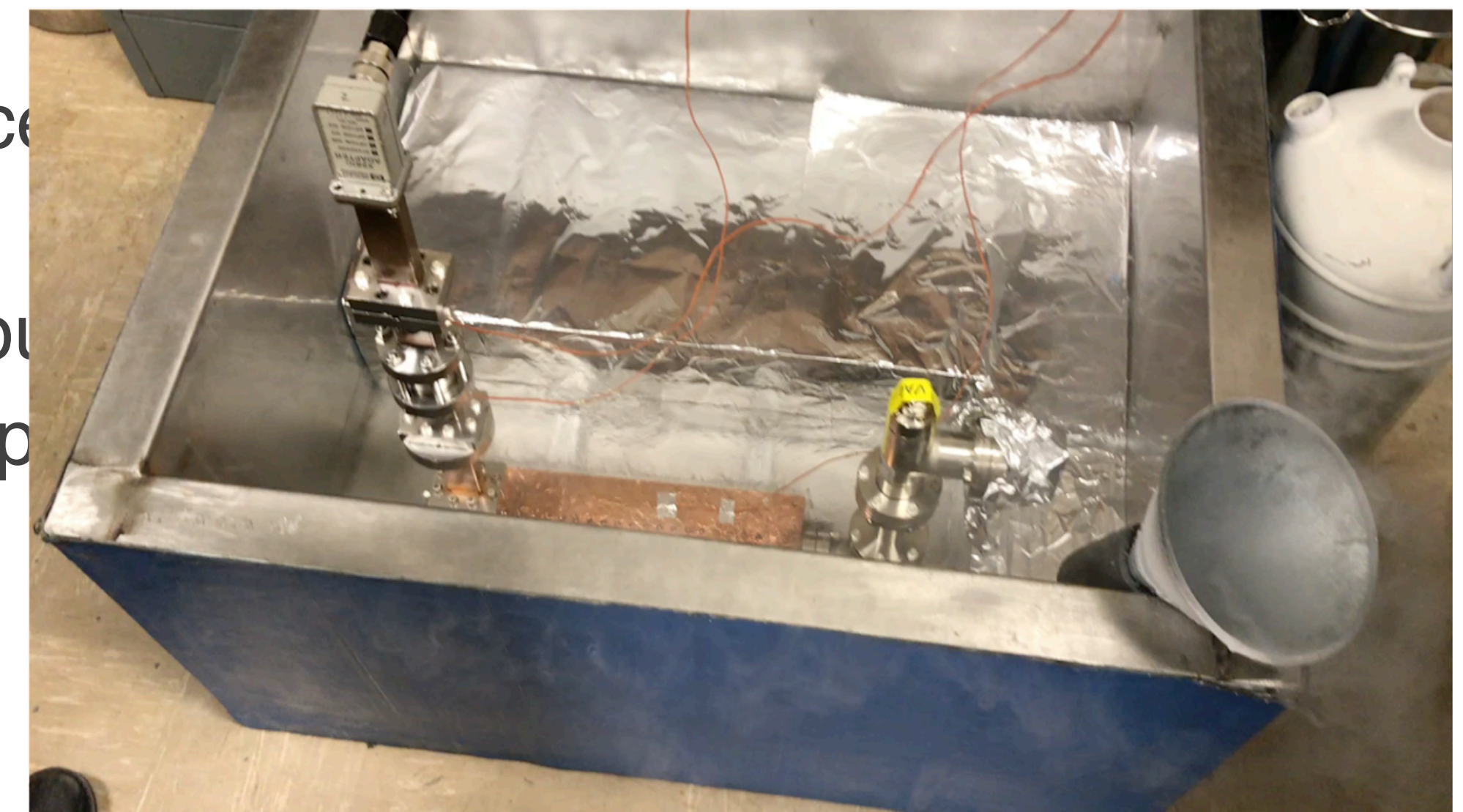
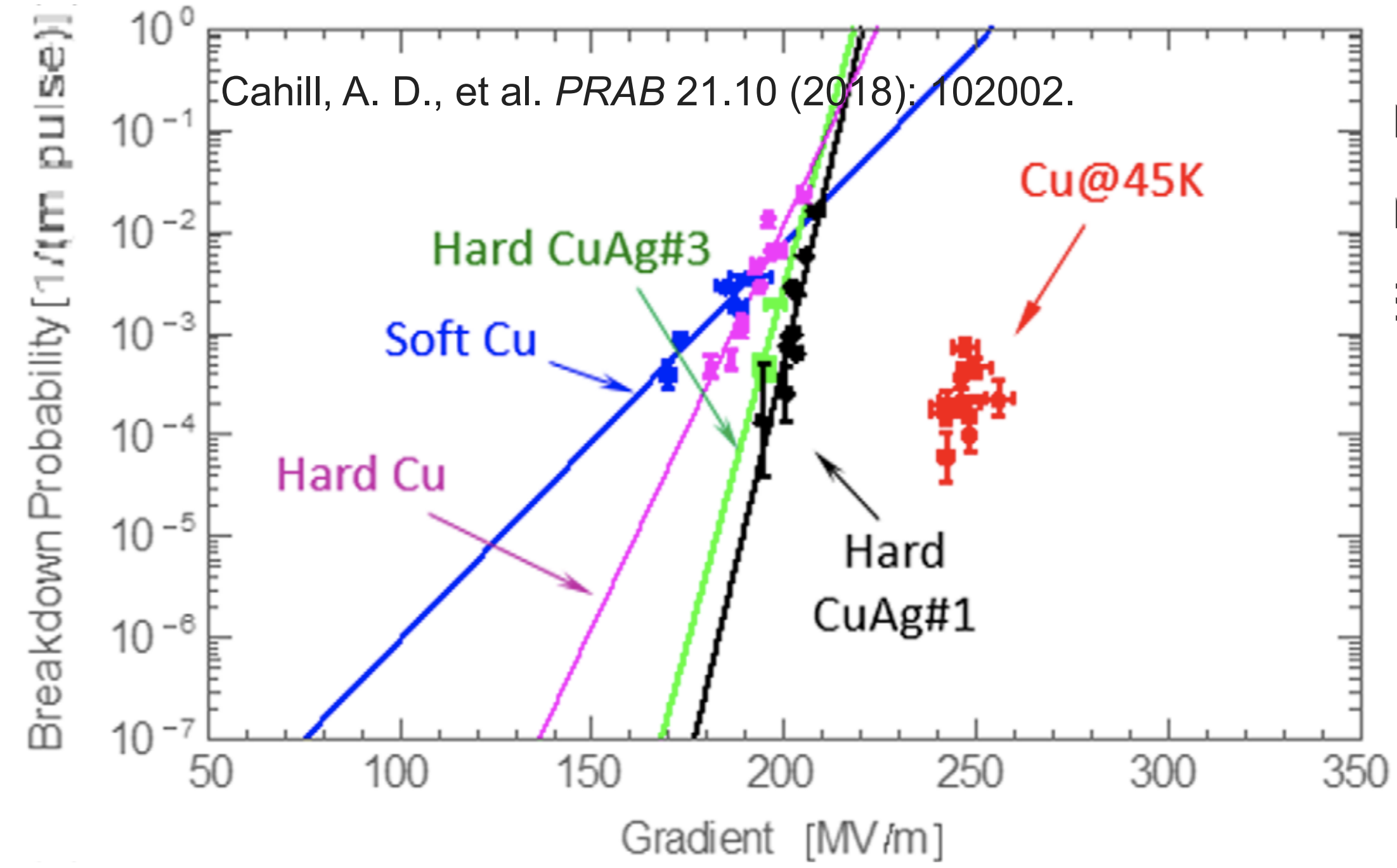

ince  
it  
s pu  
mp



# Expected gradient

- Robust operations at high gradient: 120 MeV/m
  - Start at 70 MeV/m for C<sup>3</sup>-250
- Scalable to multi-TeV operations

## High Gradient Operation at 150 MV/m

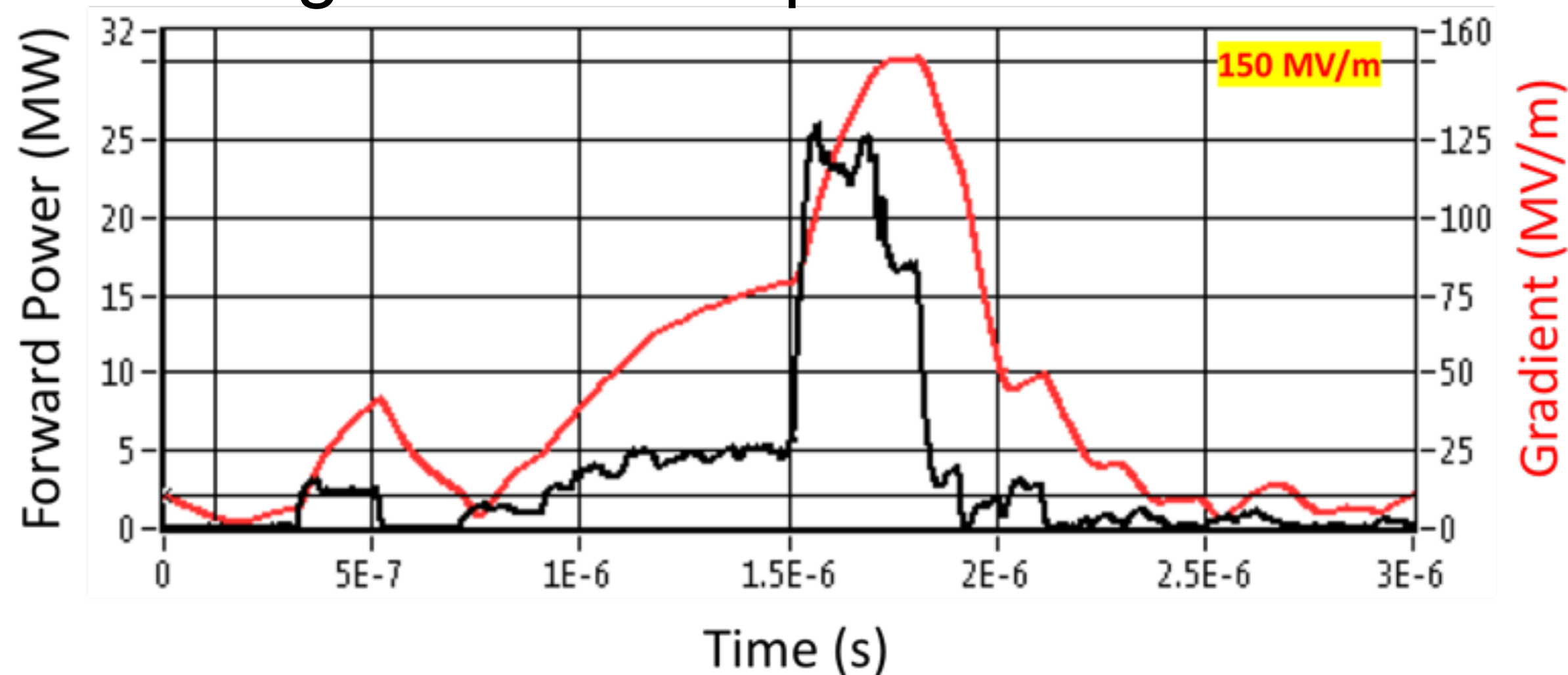

## Cryogenic Operation at X-band

## High Power Test at Radiabeam

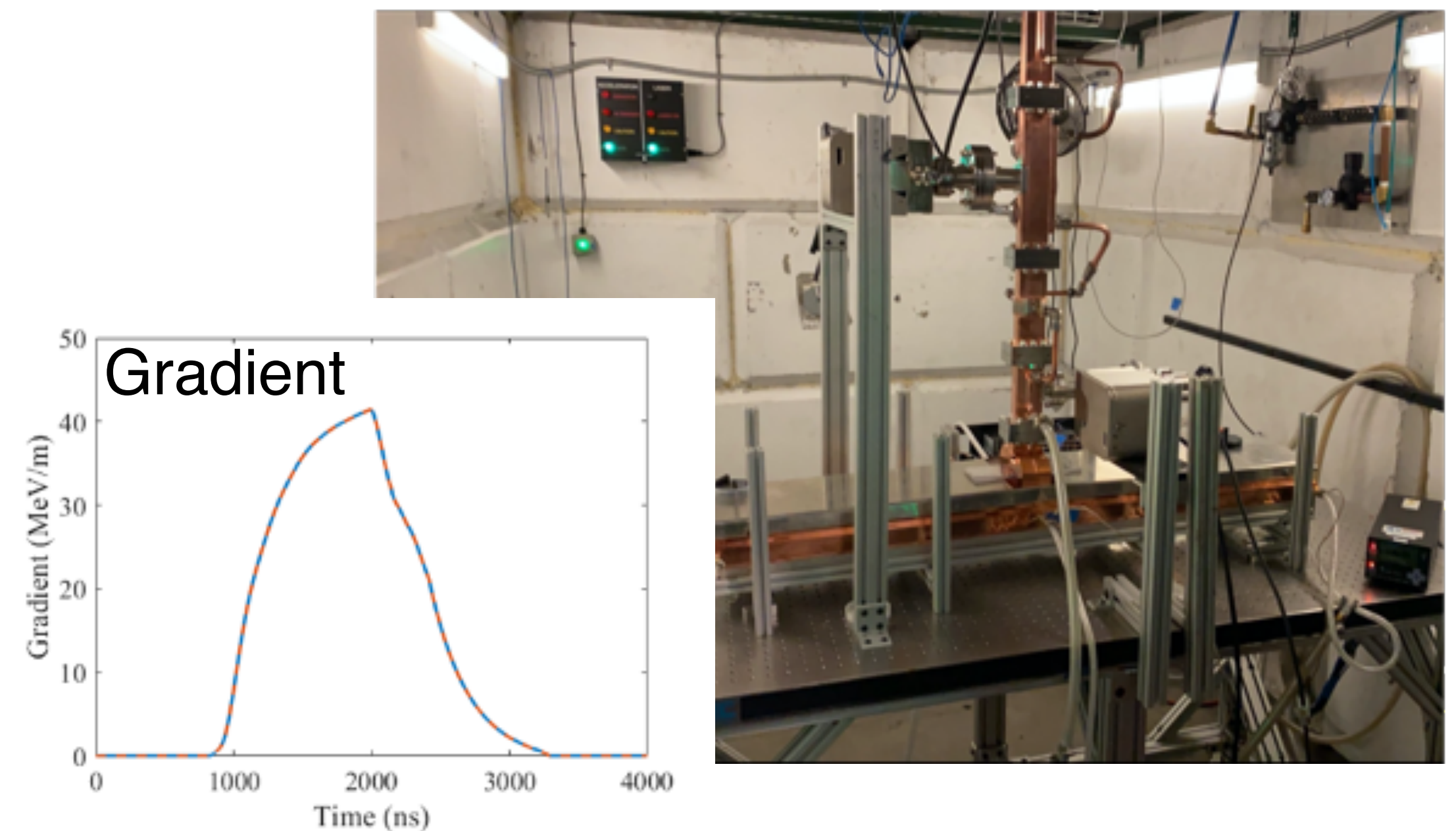

# One highlight: damping & detuning

- P5 Town Hall
- Multi-bunch simulation studies have been conducted to identify required damping and detuning to mitigate long-range HOMs
  - Single bunch studies also used for studying alignment tolerance
  - Ni-Cr coatings for two-cells structures have been tested

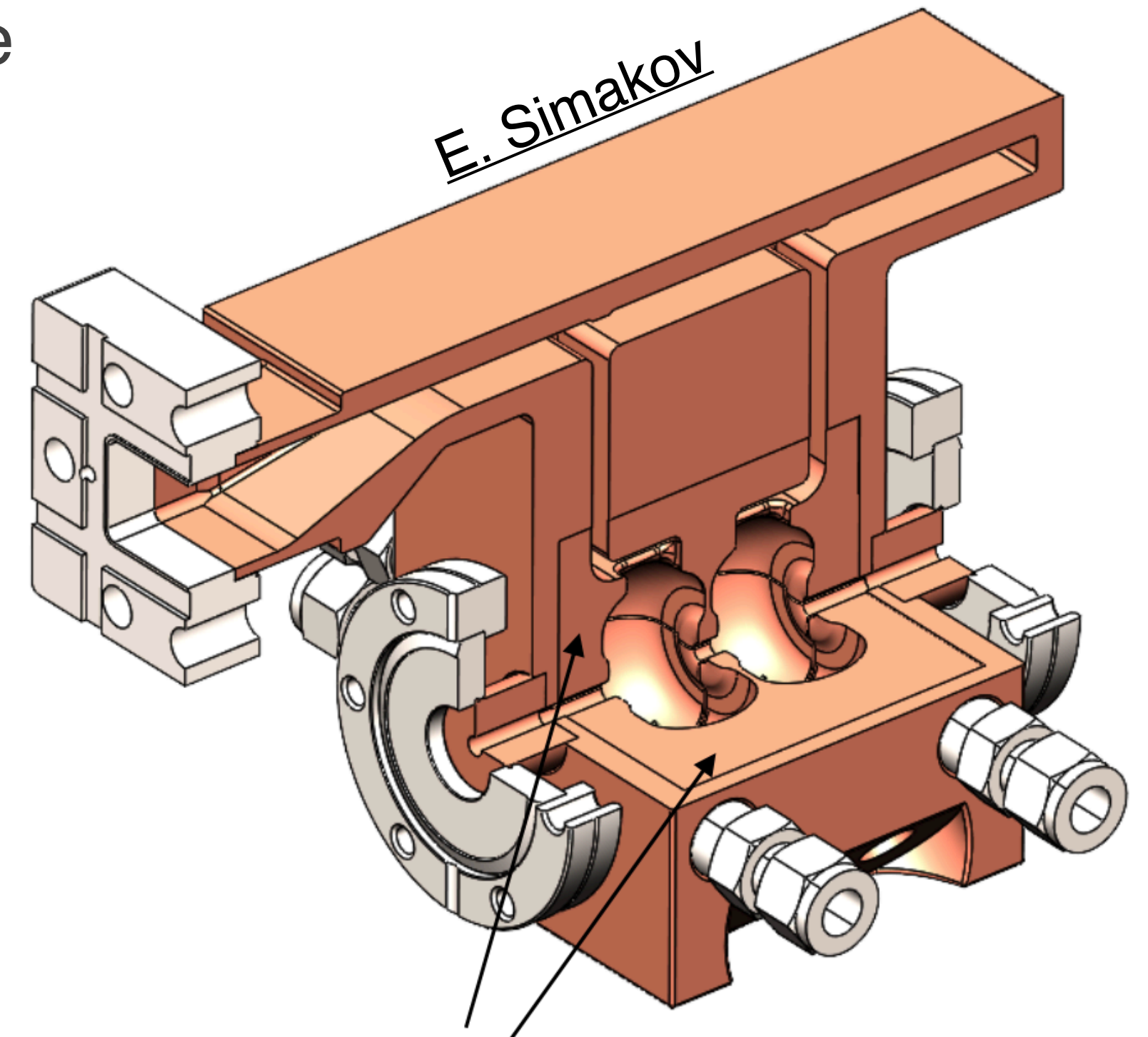
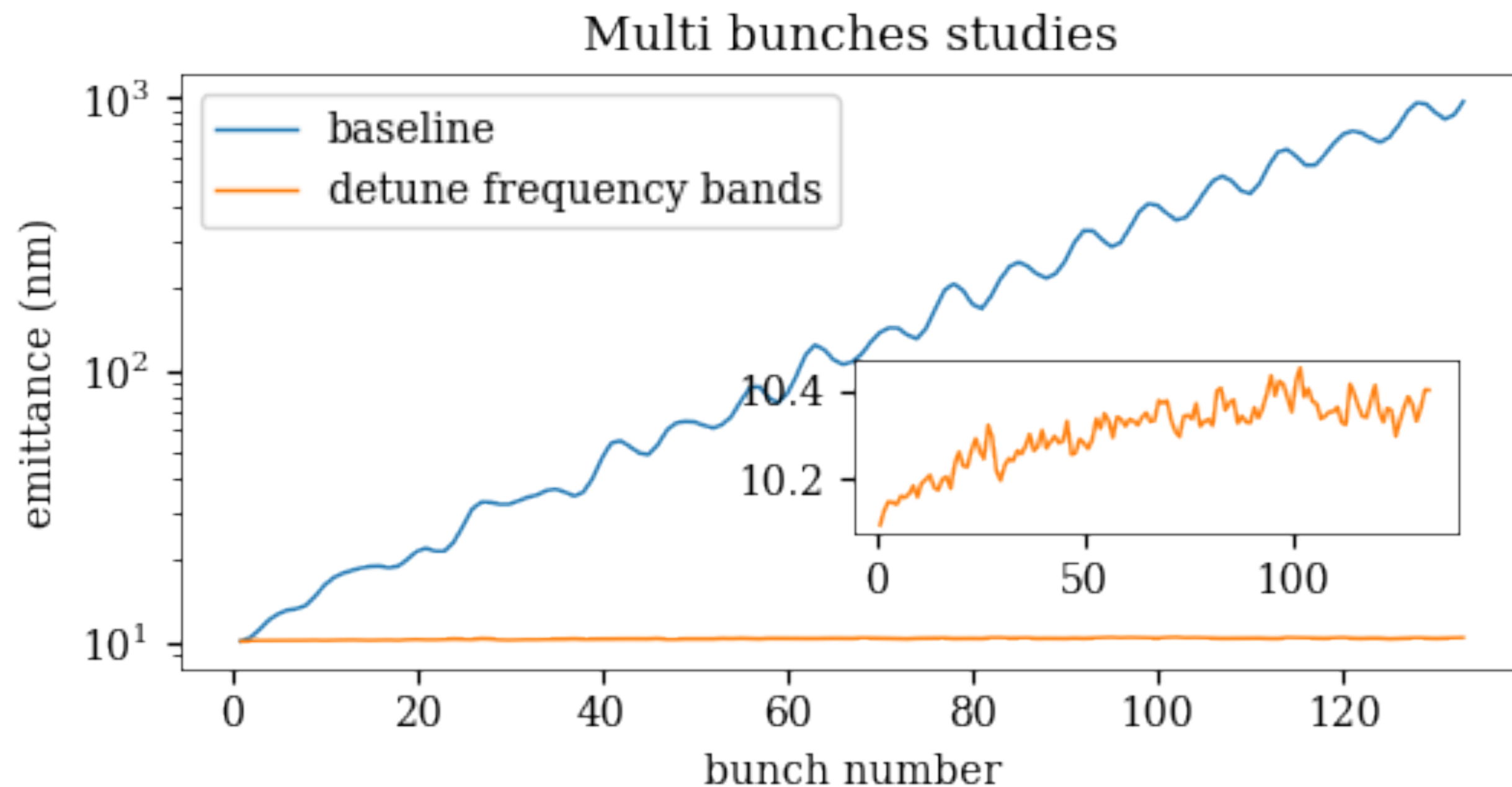

Absorber slots will be covered with NiCr



# post-P5 roadmap

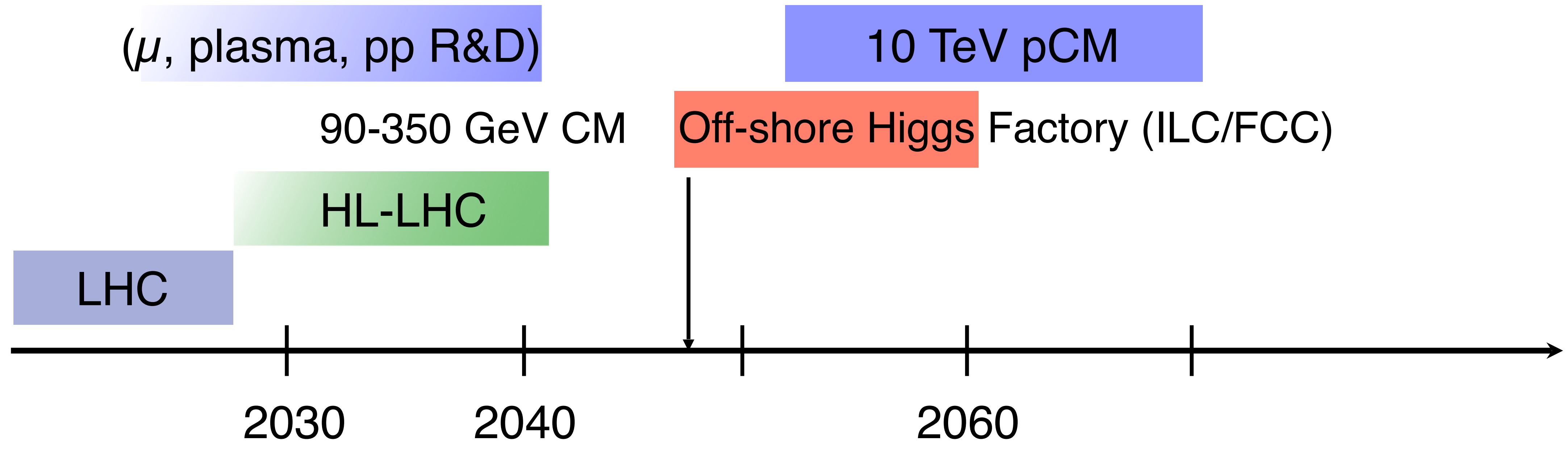

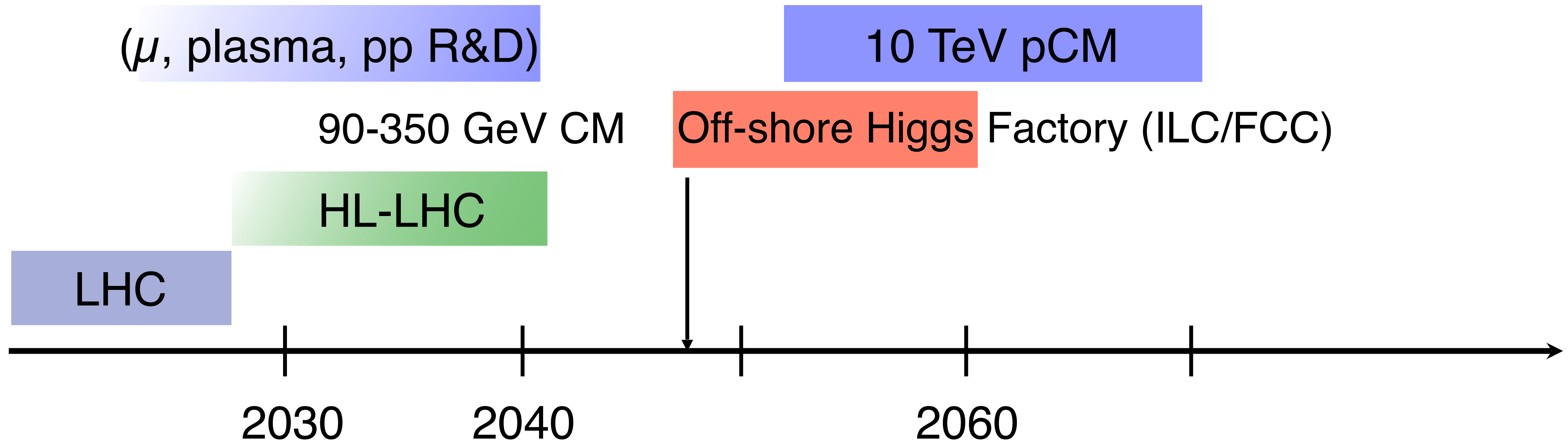

<b>H couplings to:</b>	<b>O(5-10)%</b>	<b>O(0.1-1)%</b>	
<b>H self-coupling to:</b>	<b>O(50)%</b>	<b>O(20)%</b>	<b>O(1)%</b>

# post-P5 roadmap

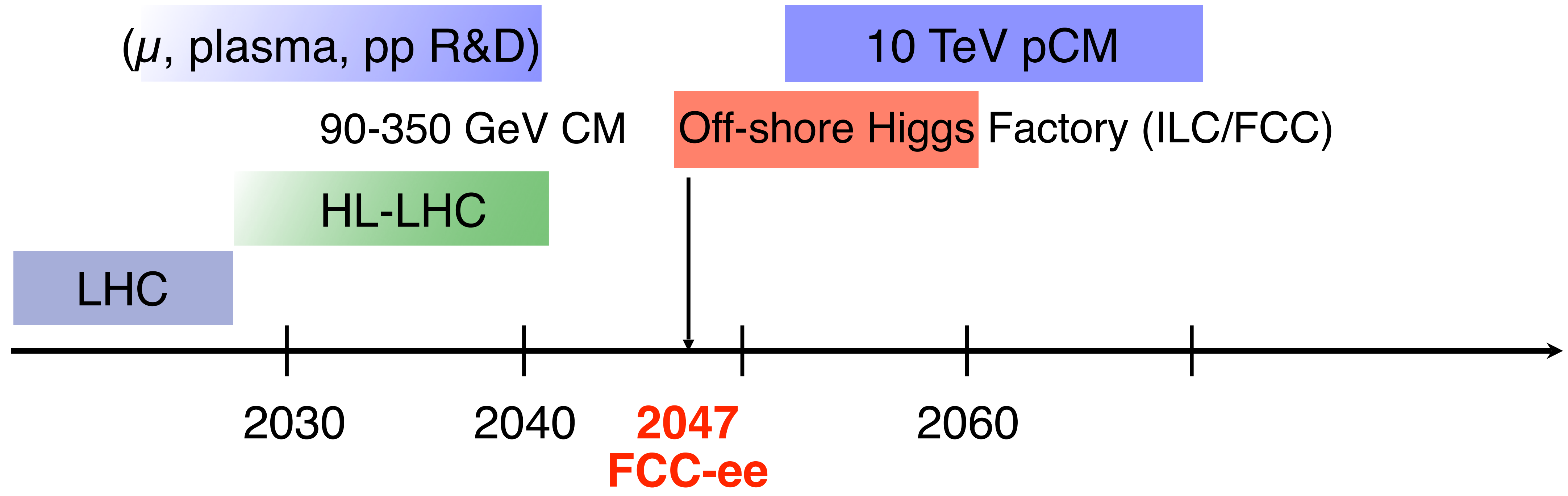

# post-P5 roadmap

P5 report

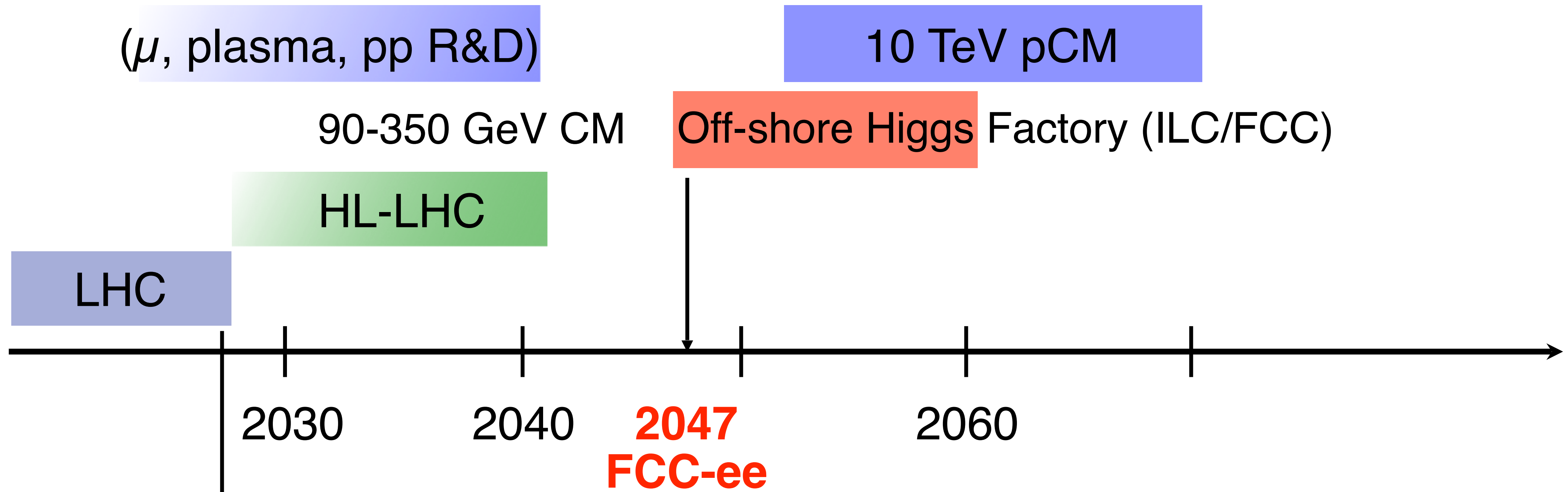

European Strategy for Particle Physics Update  
FCC feasibility study report

# A couple of highlights

More in [Ankur's talk](#)

- S-Band injector linac development: low emittance for up to 14 nC bunches while accelerating them at 18 MV/m
  - Targeting Efficient Acceleration of High Charge Bunches
  - S-Band structure assembly and tuning is complete
- Prototype C3 Linac with a resistive heater was used to test vibration within LN up to 2 kW

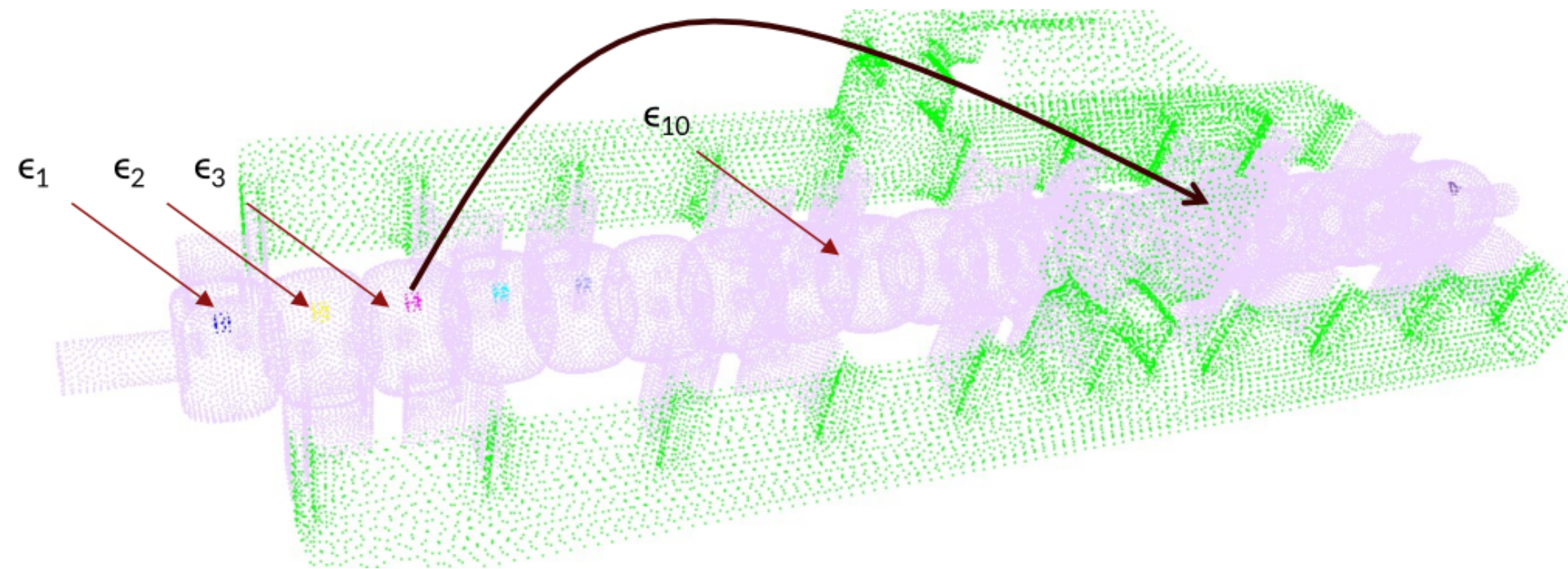
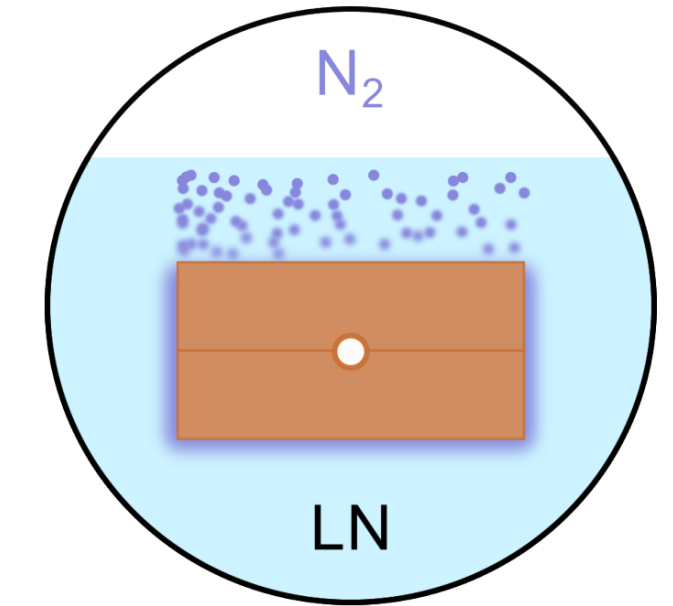

Y Displacement seen by Beam

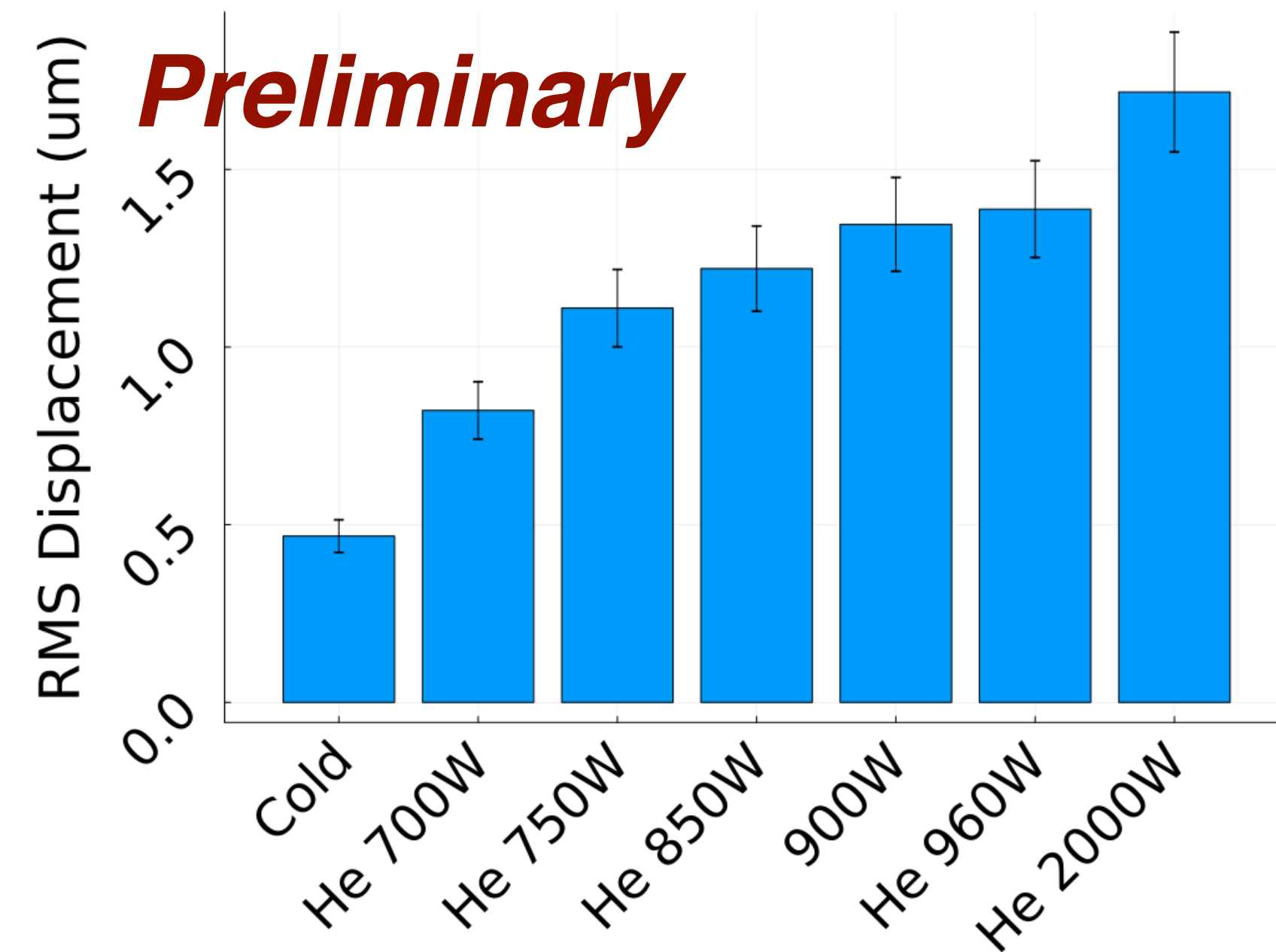

# Why 550 GeV?

A factor two in the top-yukawa couplin

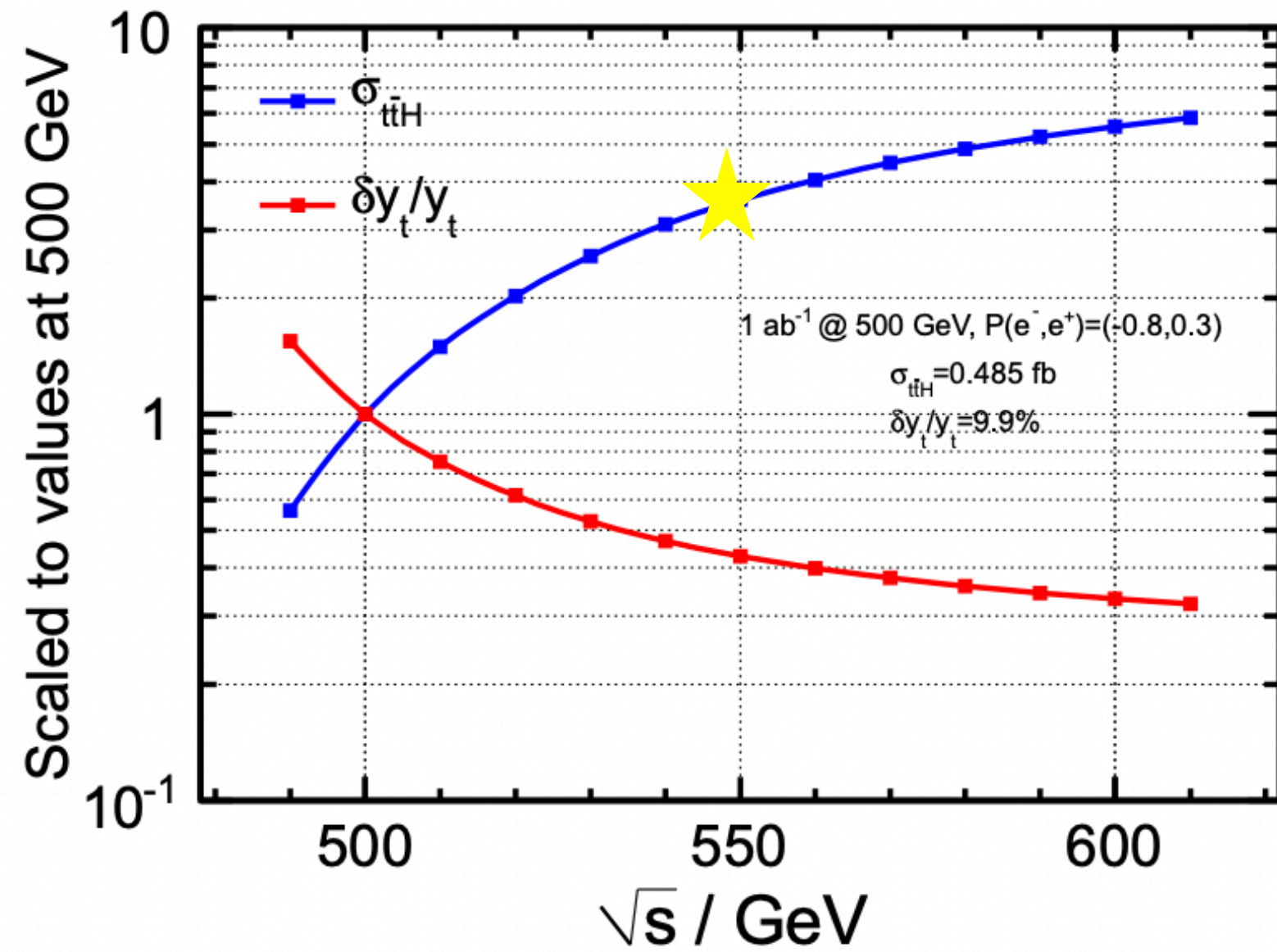

Collider Luminosity Polarization	HL-LHC 3 ab <sup>-1</sup> in 10 yrs -	C <sup>3</sup> /ILC 250 GeV 2 ab <sup>-1</sup> in 10 yrs $\mathcal{P}_{e^+} = 30\%$ (0%)	C <sup>3</sup> /ILC 500 GeV + 4 ab <sup>-1</sup> in 10 yrs $\mathcal{P}_{e^+} = 30\%$ (0%)
$g_{HZZ}$ (%)	3.2	0.38 (0.40)	0.20 (0.21)
$g_{HWW}$ (%)	2.9	0.38 (0.40)	0.20 (0.20)
$g_{Hbb}$ (%)	4.9	0.80 (0.85)	0.43 (0.44)
$g_{Hcc}$ (%)	-	1.8 (1.8)	1.1 (1.1)
$g_{Hgg}$ (%)	2.3	1.6 (1.7)	0.92 (0.93)
$g_{H\tau\tau}$ (%)	3.1	0.95 (1.0)	0.64 (0.65)
$g_{H\mu\mu}$ (%)	3.1	4.0 (4.0)	3.8 (3.8)
$g_{H\gamma\gamma}$ (%)	3.3	1.1 (1.1)	0.97 (0.97)
$g_{HZ\gamma}$ (%)	11.	8.9 (8.9)	6.5 (6.8)
$g_{Htt}$ (%)	3.5	-	3.0 (3.0)*
$g_{HHH}$ (%)	50	49 (49)	22 (22)
$\Gamma_H$ (%)	5	1.3 (1.4)	0.70 (0.70)

# Why 550 GeV?

A factor two in the top-yukawa couplin

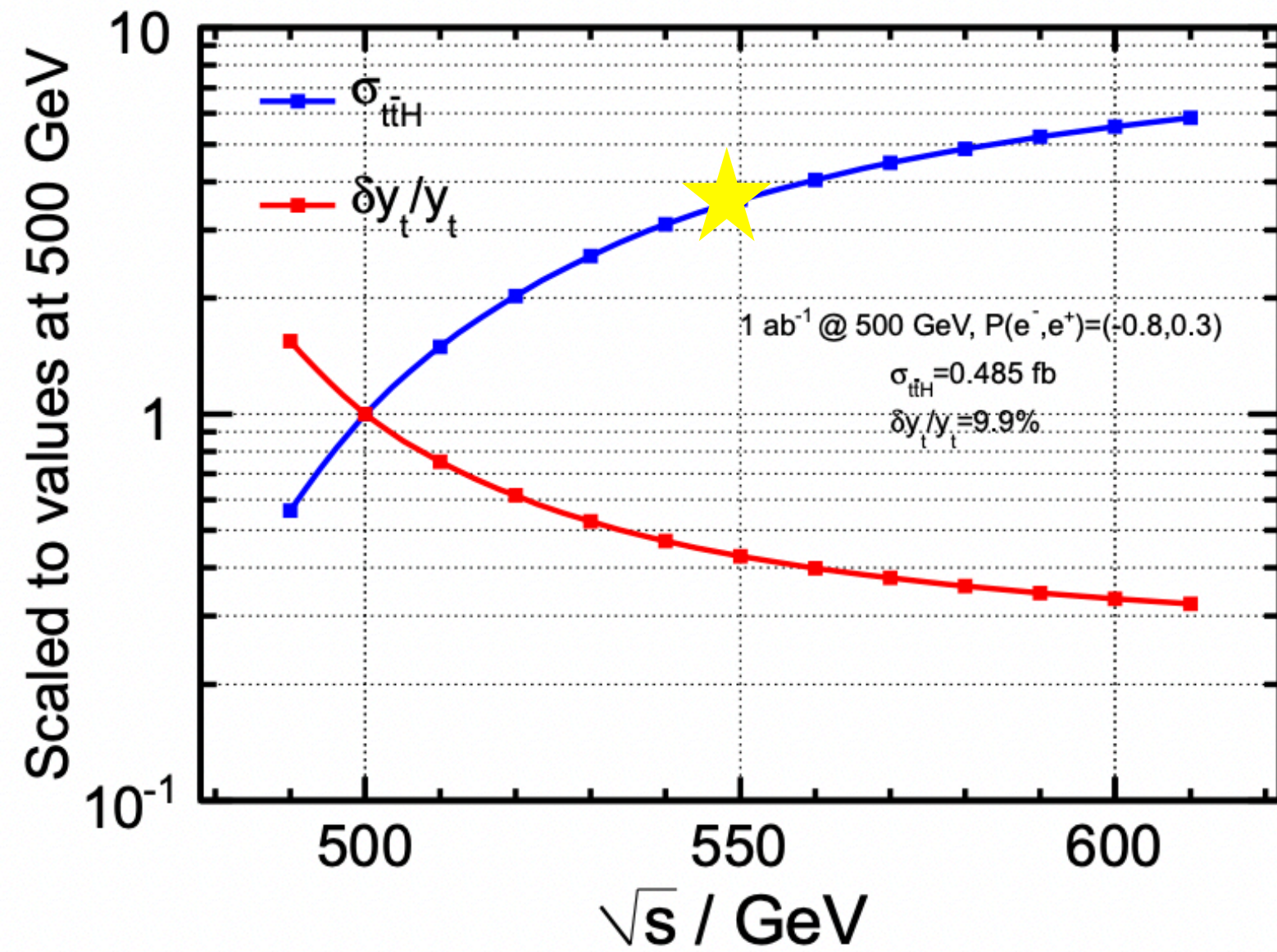

Collider Luminosity Polarization	HL-LHC 3 ab <sup>-1</sup> in 10 yrs -	C <sup>3</sup> /ILC 250 GeV 2 ab <sup>-1</sup> in 10 yrs $\mathcal{P}_{e^+} = 30\%$ (0%)	C <sup>3</sup> /ILC 500 GeV + 4 ab <sup>-1</sup> in 10 yrs $\mathcal{P}_{e^+} = 30\%$ (0%)
$g_{HZZ}$ (%)	3.2	0.38 (0.40)	0.20 (0.21)
$g_{HWW}$ (%)	2.9	0.38 (0.40)	0.20 (0.20)
$g_{Hbb}$ (%)	4.9	0.80 (0.85)	0.43 (0.44)
$g_{Hcc}$ (%)	-	1.8 (1.8)	1.1 (1.1)
$g_{Hgg}$ (%)	2.3	1.6 (1.7)	0.92 (0.93)
$g_{H\tau\tau}$ (%)	3.1	0.95 (1.0)	0.64 (0.65)
$g_{H\mu\mu}$ (%)	3.1	4.0 (4.0)	3.8 (3.8)
$g_{H\gamma\gamma}$ (%)	3.3	1.1 (1.1)	0.97 (0.97)
$g_{HZ\gamma}$ (%)	11.	8.9 (8.9)	6.5 (6.8)
$g_{Htt}$ (%)	3.5	-	3.0 (3.0)*
$g_{HHH}$ (%)	50	49 (49)	22 (22)
$\Gamma_H$ (%)	5	1.3 (1.4)	0.70 (0.70)

**O(20%) precision on the Higgs self-coupling would allow to exclude/  
demonstrate at 5 $\sigma$  models of electroweak baryogenesis**

# Top physics at $e^+e^-$

## Unique opportunities for theoretically clean precision observables

- The measurement of the  $t\bar{t}$  cross-section with a threshold scan can determine the top mass with 50 MeV uncertainty
- Global fits demonstrate  $e^+e^-$  sensitivity of 10-100 times above HL-LHC for some operators top electroweak couplings at energies  $> 500$  GeV

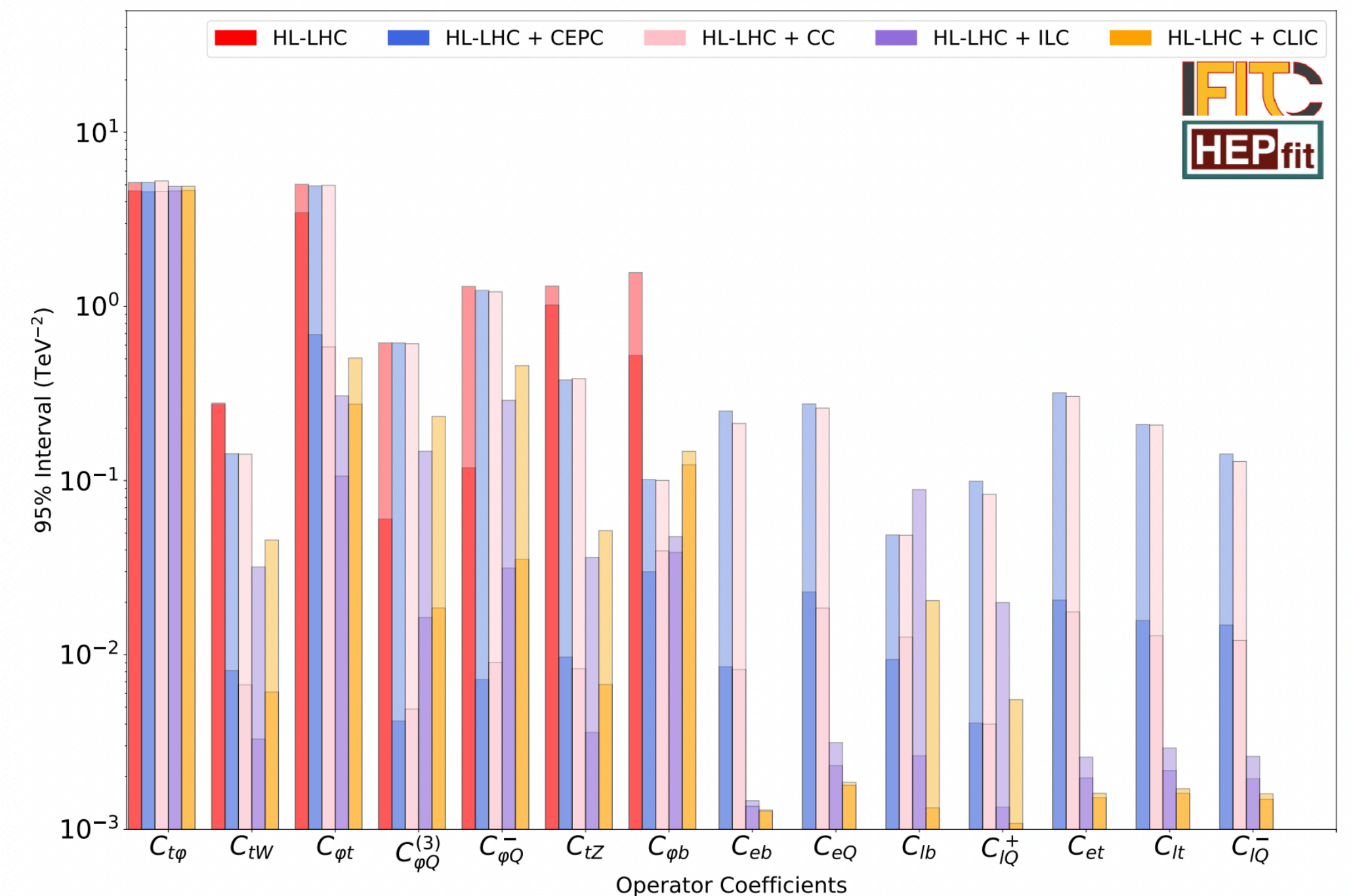
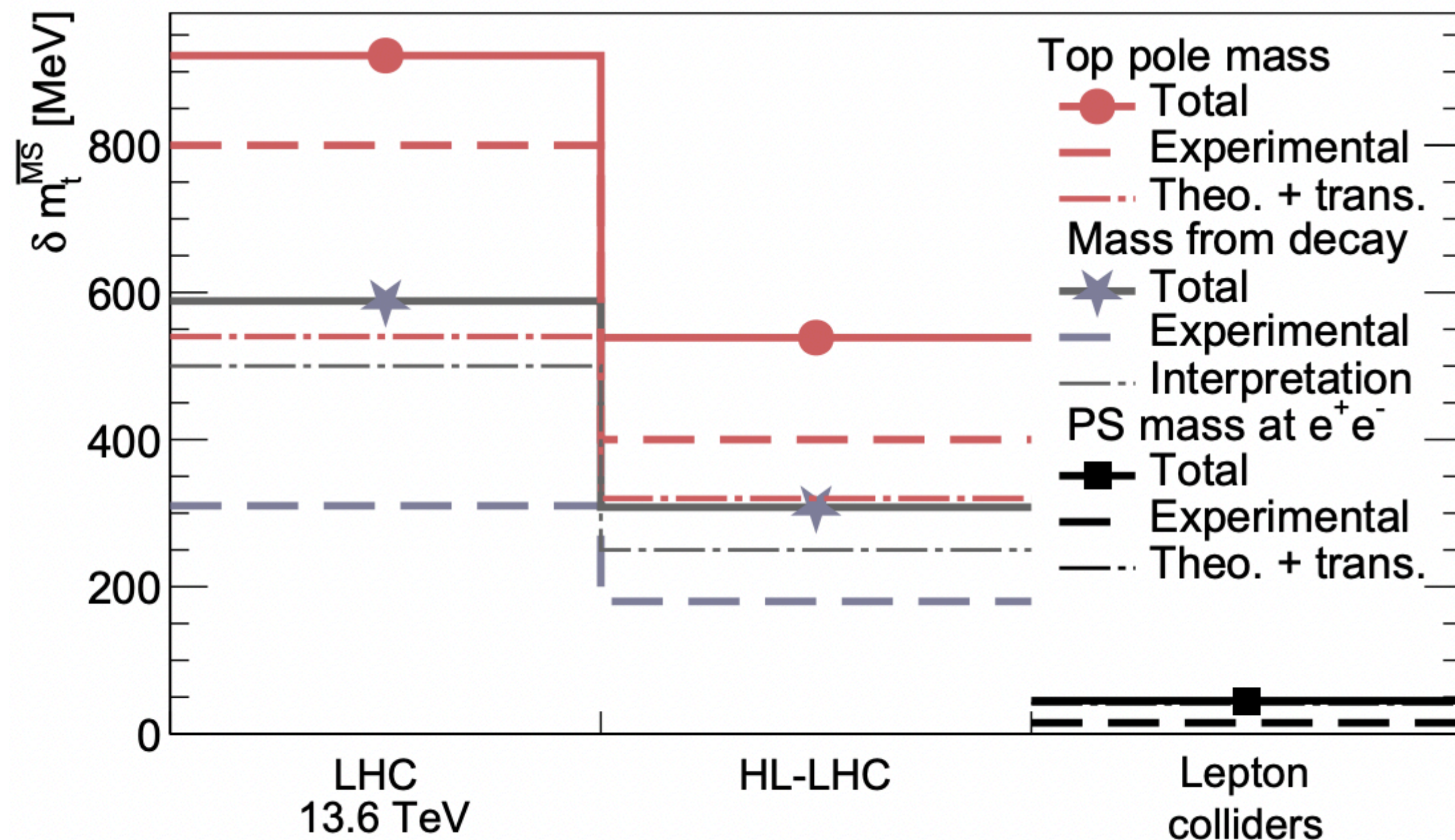

# Current benchmarks and next steps

The goal of measuring Higgs properties with sub-% precision translates into ambitious requirements for detectors at  $e^+e^-$

- Requirements mostly driven by (Higgs) specific benchmarks
- Technological advances can open new opportunities and additional physics benchmarks (i.e.  $H \rightarrow ss$ ) can add more stringent requirements

Physics goal	Detector	Requirement
$hZZ$ sub-%	Tracker	$\sigma_{p_T}/p_T = 0.2\%$ for $p_T < 100$ GeV
	Calorimeter	$\sigma_{p_T}/p_T^2 = 2 \cdot 10^{-5} / \text{GeV}$ for $p_T > 100$ GeV 4% particle flow jet resolution EM cells $0.5 \times 0.5 \text{ cm}^2$ , HAD cells $1 \times 1 \text{ cm}^2$ EM $\sigma_E/E = 10\%/\sqrt{E} \oplus 1\%$ shower timing resolution 10 ps
$hb\bar{b}/hc\bar{c}$	Tracker	$\sigma_{r\phi} = 5 \oplus 15(p \sin \theta^{\frac{3}{2}})^{-1} \mu\text{m}$ 5 $\mu\text{m}$ single hit resolution

[Arxiv:2209.14111](https://arxiv.org/abs/2209.14111) [Arxiv:2211.11084](https://arxiv.org/abs/2211.11084) DOE Basic Research Needs Study on Instrumentation

Topic	Lead group	Relevant $\sqrt{s}$ [GeV]				
		91	161	240–250	350–380	$\geq 500$
1 HtoSS	HTE			✓	✓	✓
2 ZHang	HTE (GLOB)			✓	✓	✓
3 Hself	GLOB			✓	✓	✓

# Current benchmarks and next steps

The goal of measuring Higgs properties with sub-% precision translates into ambitious requirements for detectors at  $e^+e^-$

- Requirements mostly driven by (Higgs) specific benchmarks
- Technological advances can open new opportunities and additional physics benchmarks (i.e.  $H \rightarrow ss$ ) can add more stringent requirements

Physics goal	Detector	Requirement
$hZZ$ sub-%	Tracker	$\sigma_{p_T}/p_T = 0.2\%$ for $p_T < 100$ GeV $\sigma_{p_T}/p_T^2 = 2 \cdot 10^{-5} / \text{GeV}$ for $p_T > 100$ GeV
	Calorimeter	4% particle flow jet resolution EM cells $0.5 \times 0.5 \text{ cm}^2$ , HAD cells $1 \times 1 \text{ cm}^2$ EM $\sigma_E/E = 10\%/\sqrt{E} \oplus 1\%$ shower timing resolution 10 ps
$hb\bar{b}/hc\bar{c}$	Tracker	$\sigma_{r\phi} = 5 \oplus 15(p \sin \theta^{\frac{3}{2}})^{-1} \mu\text{m}$ 5 $\mu\text{m}$ single hit resolution

Arxiv:2209.14111 Arxiv:2211.11084 DOE Basic Research Needs Study on Instrumentation

Topic	Lead group	Relevant $\sqrt{s}$ [GeV]				
		91	161	240–250	350–380	$\geq 500$
1 HtoSS	HTE			✓	✓	✓
2 ZHang	HTE (GLOB)			✓	✓	✓
3 Hself	GLOB			✓	✓	✓

**Focus topics for the ECFA study on Higgs / Top / EW factories should provide further detector design guidelines ([2401.07564](#)) by Spring 2025**

# Why 550 GeV?

A factor two in the top-yukawa coupling

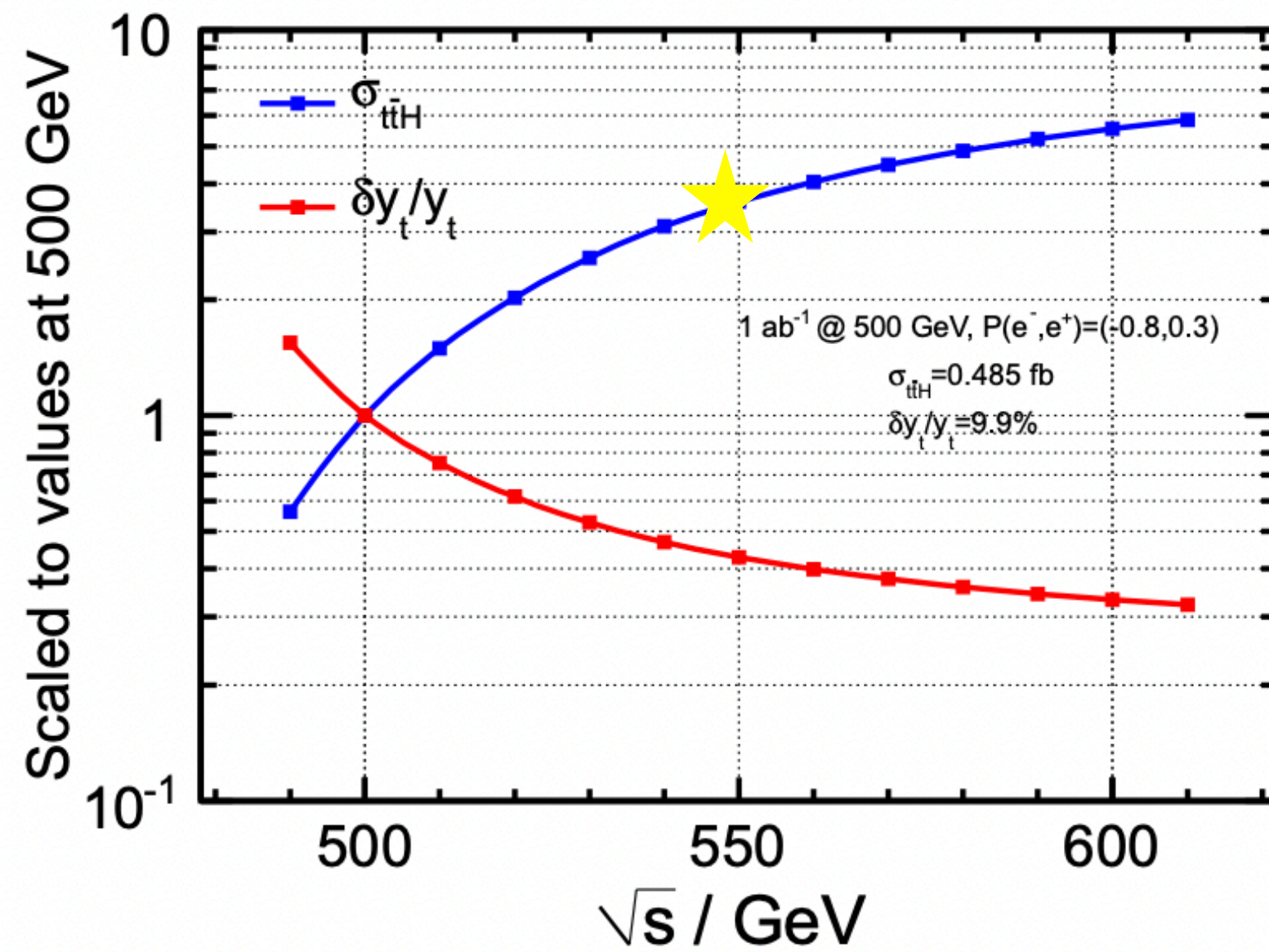

Collider Luminosity Polarization	HL-LHC 3 ab <sup>-1</sup> in 10 yrs -	C <sup>3</sup> /ILC 250 GeV 2 ab <sup>-1</sup> in 10 yrs $\mathcal{P}_{e^+} = 30\%$ (0%)	C <sup>3</sup> /ILC 500 GeV + 4 ab <sup>-1</sup> in 10 yrs $\mathcal{P}_{e^+} = 30\%$ (0%)
$g_{HZZ}$ (%)	3.2	0.38 (0.40)	0.20 (0.21)
$g_{HWW}$ (%)	2.9	0.38 (0.40)	0.20 (0.20)
$g_{Hbb}$ (%)	4.9	0.80 (0.85)	0.43 (0.44)
$g_{Hcc}$ (%)	-	1.8 (1.8)	1.1 (1.1)
$g_{Hgg}$ (%)	2.3	1.6 (1.7)	0.92 (0.93)
$g_{H\tau\tau}$ (%)	3.1	0.95 (1.0)	0.64 (0.65)
$g_{H\mu\mu}$ (%)	3.1	4.0 (4.0)	3.8 (3.8)
$g_{H\gamma\gamma}$ (%)	3.3	1.1 (1.1)	0.97 (0.97)
$g_{HZ\gamma}$ (%)	11.	8.9 (8.9)	6.5 (6.8)
$g_{Htt}$ (%)	3.5	-	3.0 (3.0)*
$g_{HHH}$ (%)	50	49 (49)	22 (22)
$\Gamma_H$ (%)	5	1.3 (1.4)	0.70 (0.70)

# The Higgs self-coupling

HL-LHC projections are conservative, as they have still to be updated since 2018

collider	Indirect- $h$	$hh$	combined
HL-LHC [78]	100-200%	50%	50%
ILC <sub>250</sub> /C <sup>3</sup> -250 [51, 52]	49%	—	49%
ILC <sub>500</sub> /C <sup>3</sup> -550 [51, 52]	38%	20%	20%
CLIC <sub>380</sub> [54]	50%	—	50%
CLIC <sub>1500</sub> [54]	49%	36%	29%
CLIC <sub>3000</sub> [54]	49%	9%	9%
FCC-ee [55]	33%	—	33%
FCC-ee (4 IPs) [55]	24%	—	24%
FCC-hh [79]	-	3.4-7.8%	3.4-7.8%
$\mu$ (3 TeV) [64]	-	15-30%	15-30%
$\mu$ (10 TeV) [64]	-	4%	4%

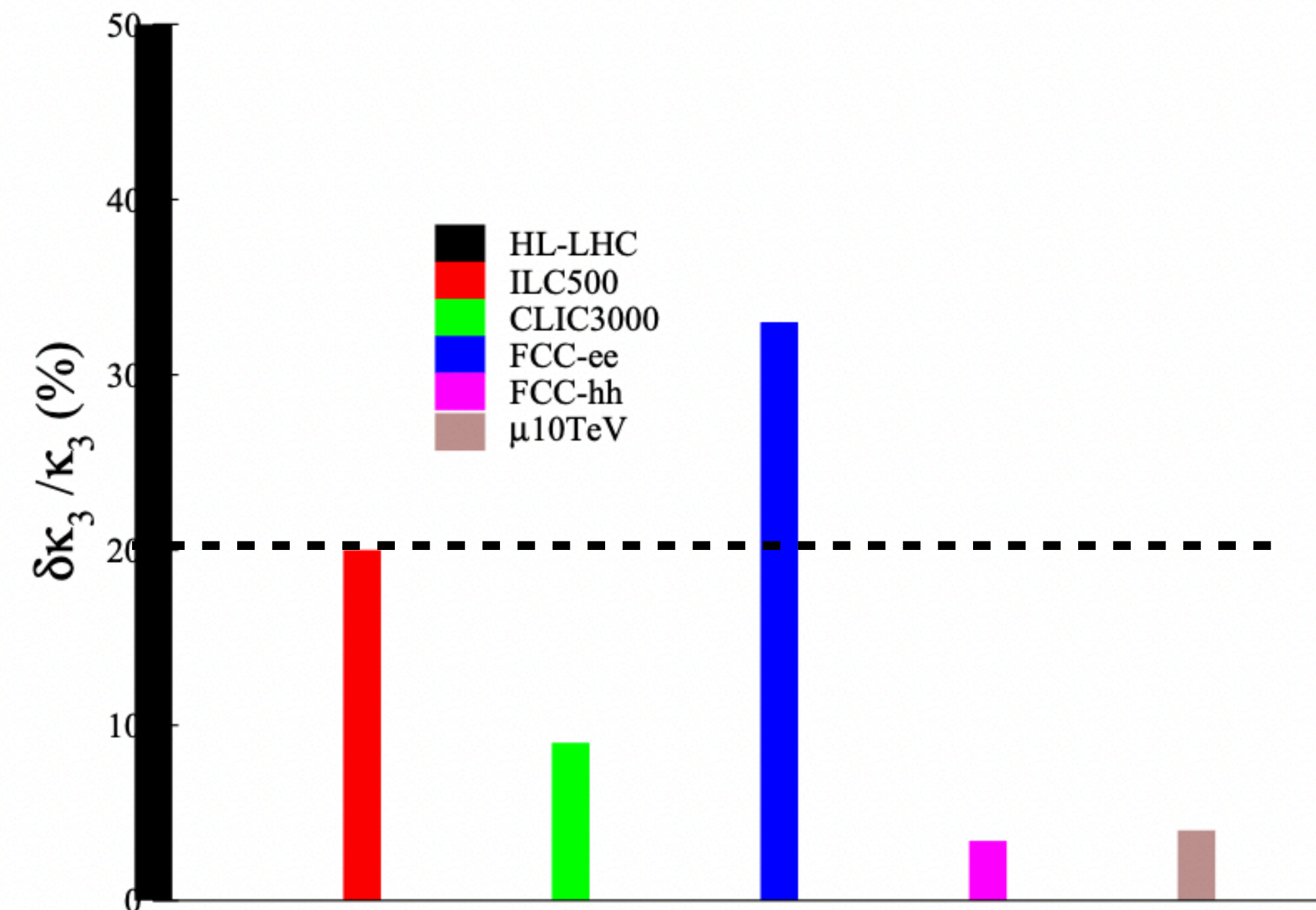

**O(20%) precision on the Higgs self-coupling would allow to exclude/demonstrate at  $5\sigma$  models of electroweak baryogenesis**

# Beam Format and Detector Design Requirements

arXiv:2003.01116  
FCC Mid Term Report

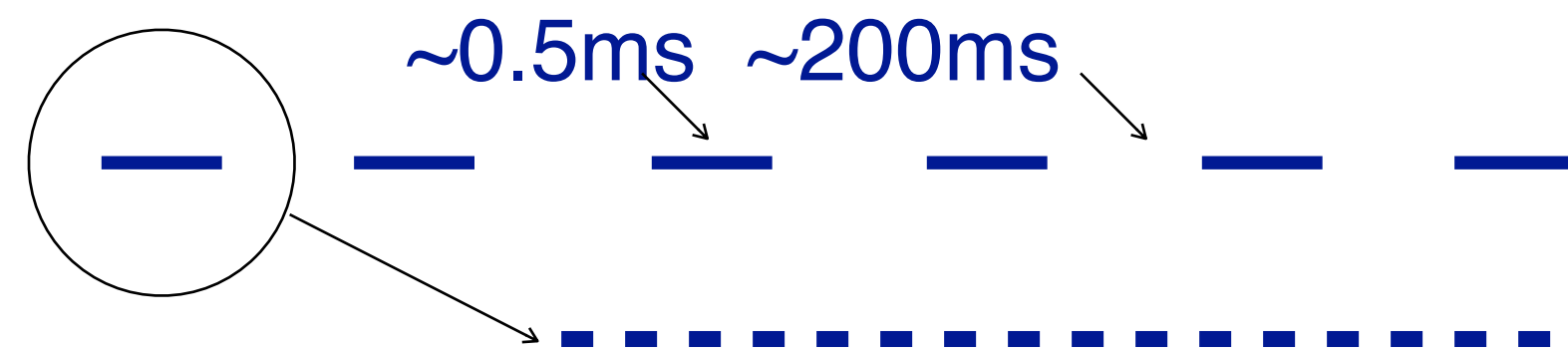

**ILC** Trains at 5Hz, 1 train 1312 bunches  
Bunches are 369 ns apart

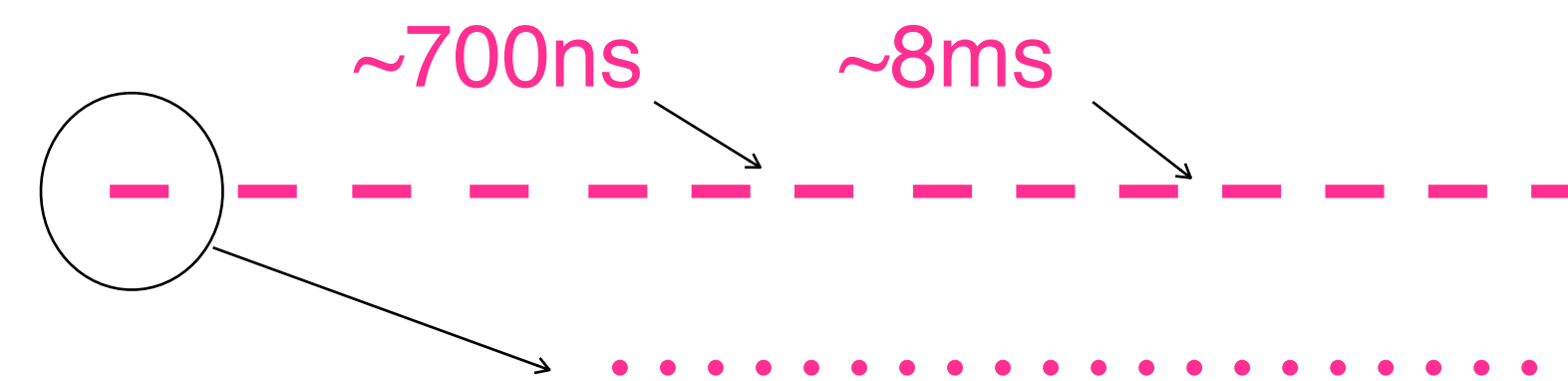

**C<sup>3</sup>** Trains at 120Hz, 1 train 133 bunches  
Bunches are 5 ns apart

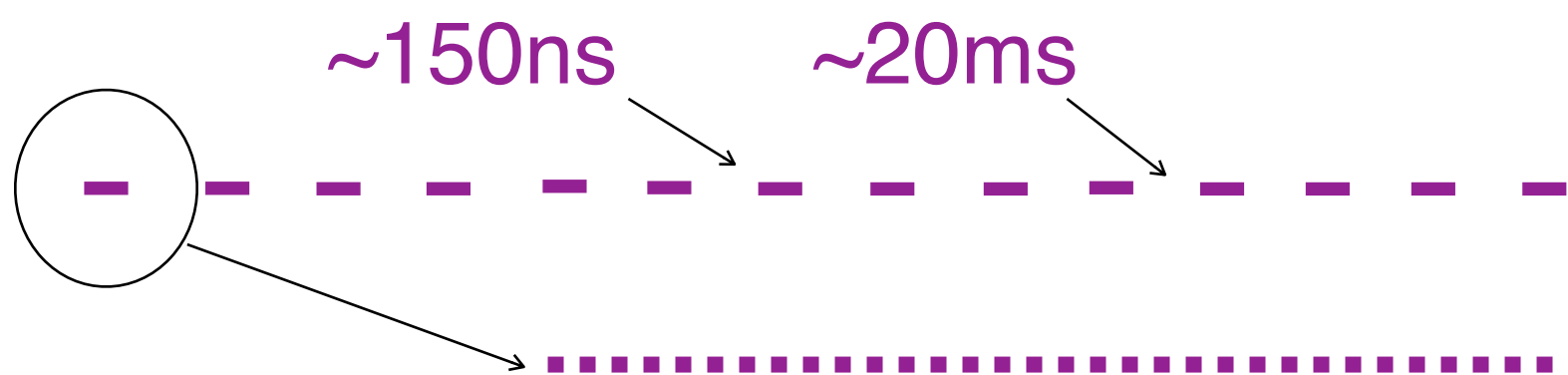

**CLIC** Trains at 50Hz, 1 train 312 bunches  
Bunches are 0.5 ns apart

- **Very low duty cycle at LC** (0.5% ILC, 0.08% C<sup>3</sup>) allows for trigger-less readout and power pulsing
  - Factor of 100 power saving for front-end analog power
- Impact of beam-induced background to be mitigated through MDI and detector design
- **O(1-100) ns bunch identification capabilities** (hit-time-stamping) can further suppress beam-backgrounds and keep occupancy low - same as for FCC-ee

# New “sustainable” parameter set ?

**Baseline**

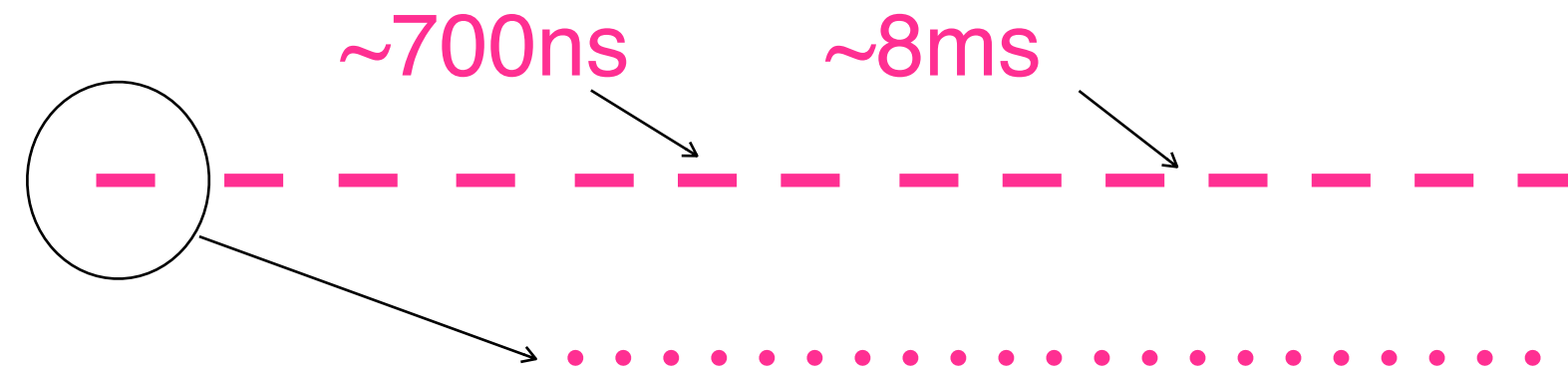

**C<sup>3</sup> Trains at 120Hz, 1 train 133 bunches**  
Bunches are 5 ns apart

**Double-flat top**

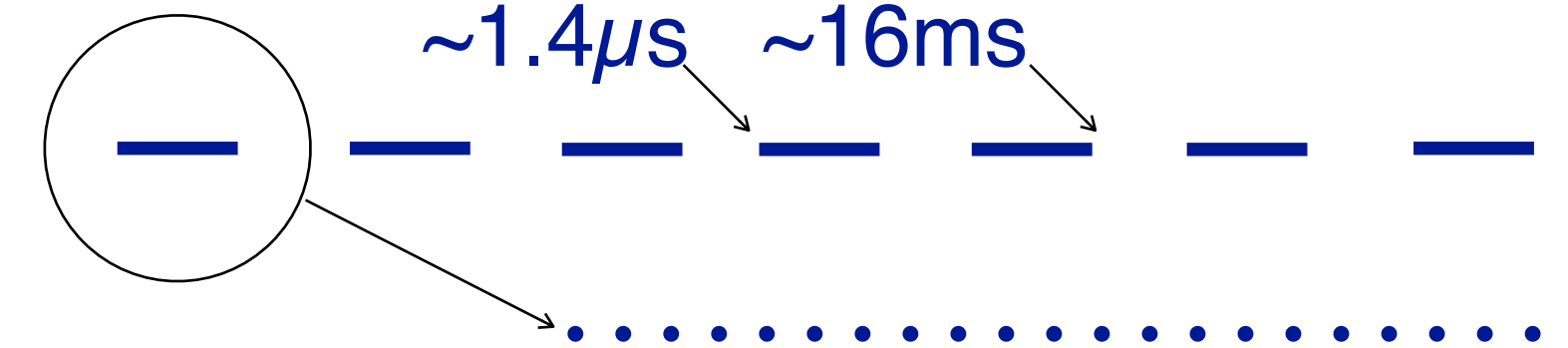

**C<sup>3</sup> Trains at 60Hz, 1 train 266 bunches**  
Bunches are 5 ns apart

**Double-flat top  
+  
Halved bunch spacing**

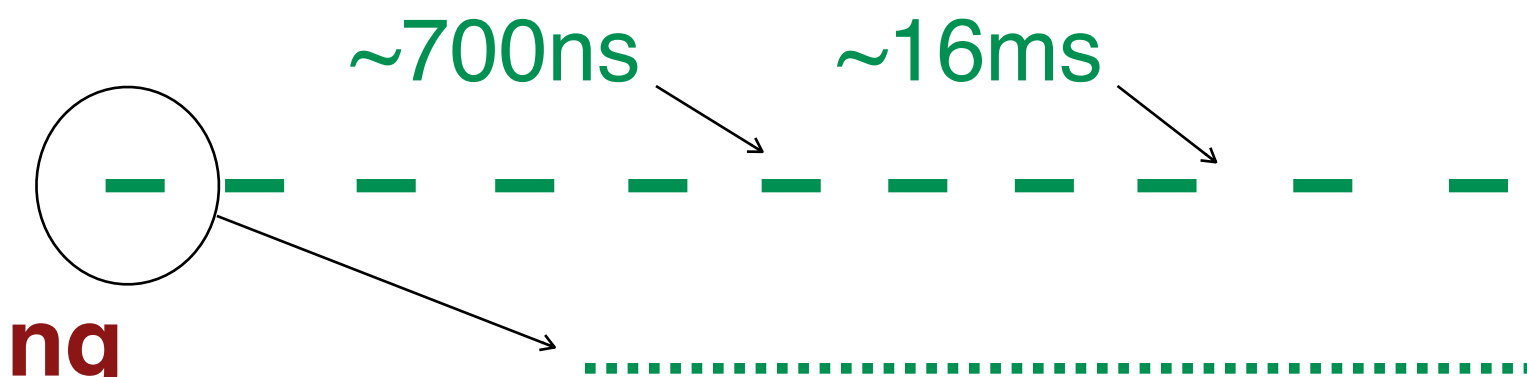

**C<sup>3</sup> Trains at 60Hz, 1 train 266 bunches**  
Bunches are 2.65 ns apart

**Constant luminosity**

# New “sustainable” parameter set ?

scenario	C <sup>3</sup> -250	C <sup>3</sup> -550	C <sup>3</sup> -250 s.u.	C <sup>3</sup> -550 s.u.
Luminosity [x10 <sup>34</sup> ]	1.3	2.4	1.3	2.4
Gradient [MeV/m]	70	120	70	120
Effective Gradient [MeV/m]	63	108	63	108
Length [km]	8	8	8	8
Num. Bunches per Train	133	75	<b>266</b>	<b>150</b>
Train Rep. Rate [Hz]	120	120	<b>60</b>	<b>60</b>
Bunch Spacing [ns]	5.26	3.5	<b>2.65</b>	<b>1.65</b>
Bunch Charge [nC]	1	1	1	1
Crossing Angle [rad]	0.014	0.014	0.014	0.014
Single Beam Power [MW]	2	2.45	2	2.45
Site Power [MW]	~150	~175	<b>~110</b>	<b>~125</b>

# Technical Timeline for 250/550 GeV CoM

P5 Town Hall

Energy upgrade in parallel to operation with installation of additional RF power sources

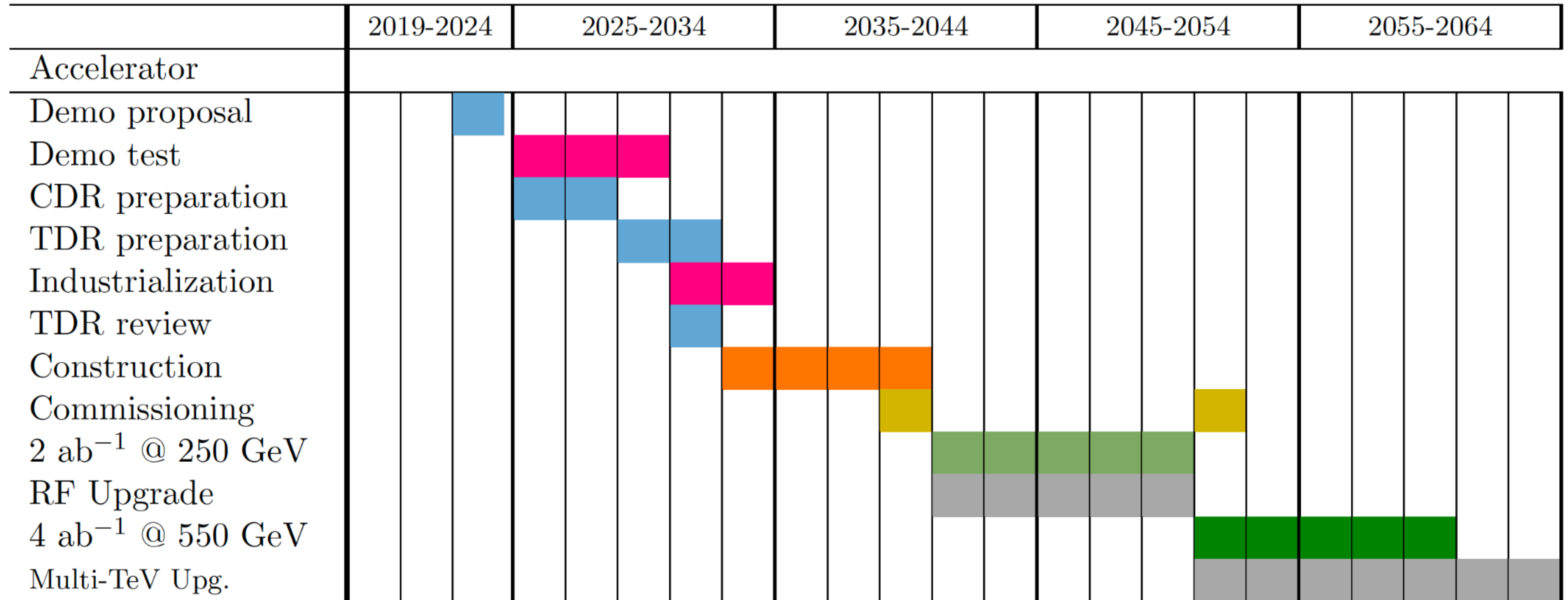

HL-LHC

# Luminosity optimization

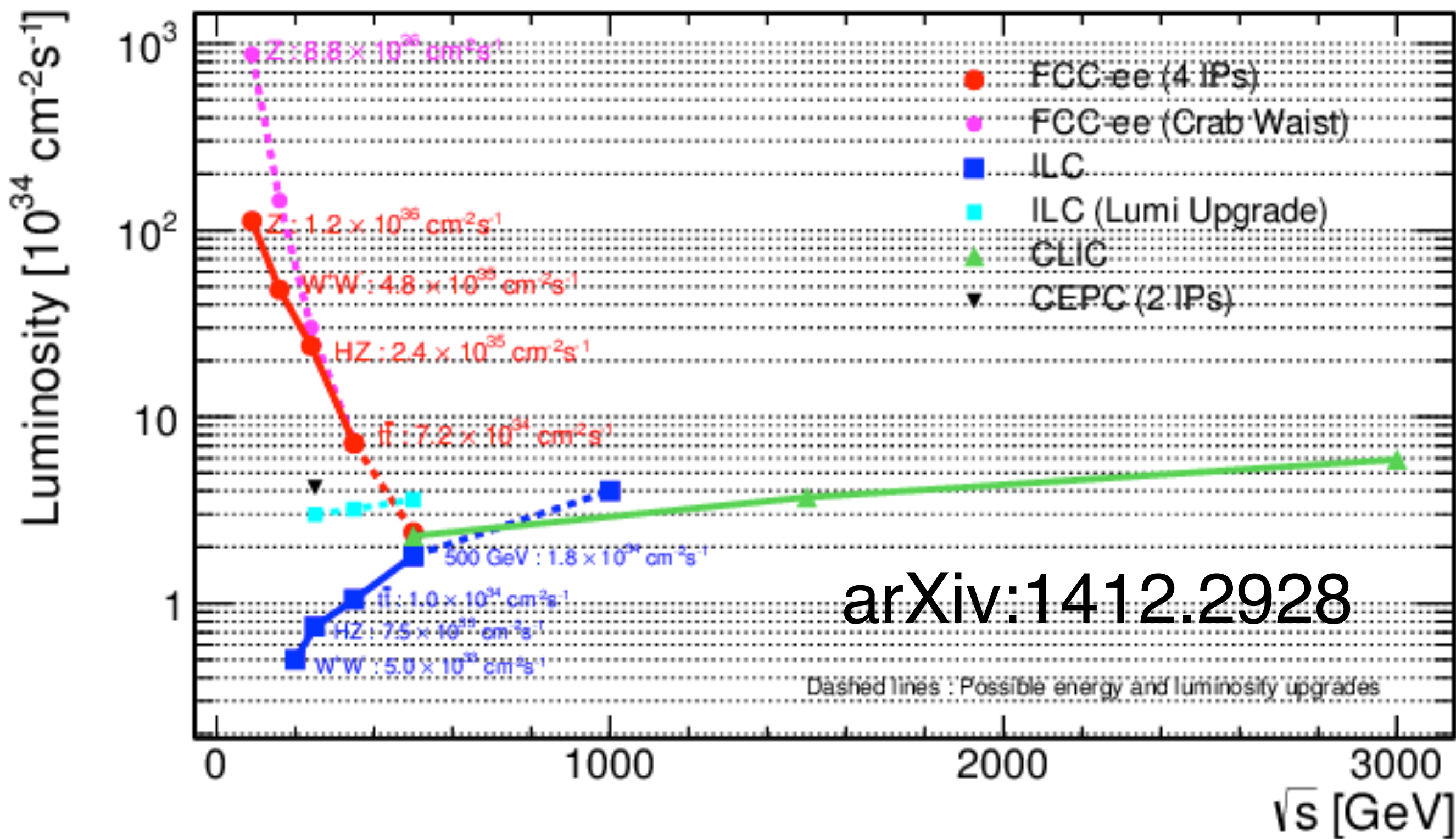

arXiv:1412.2928

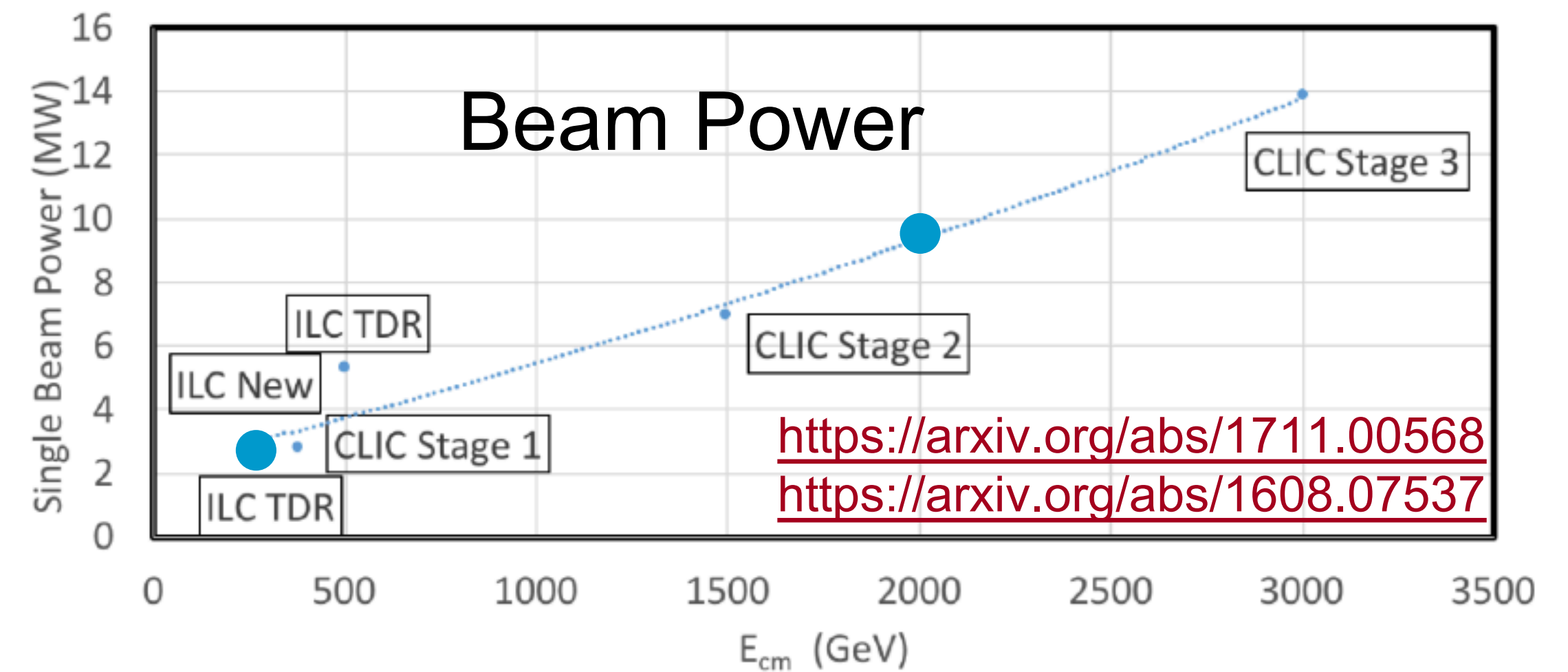
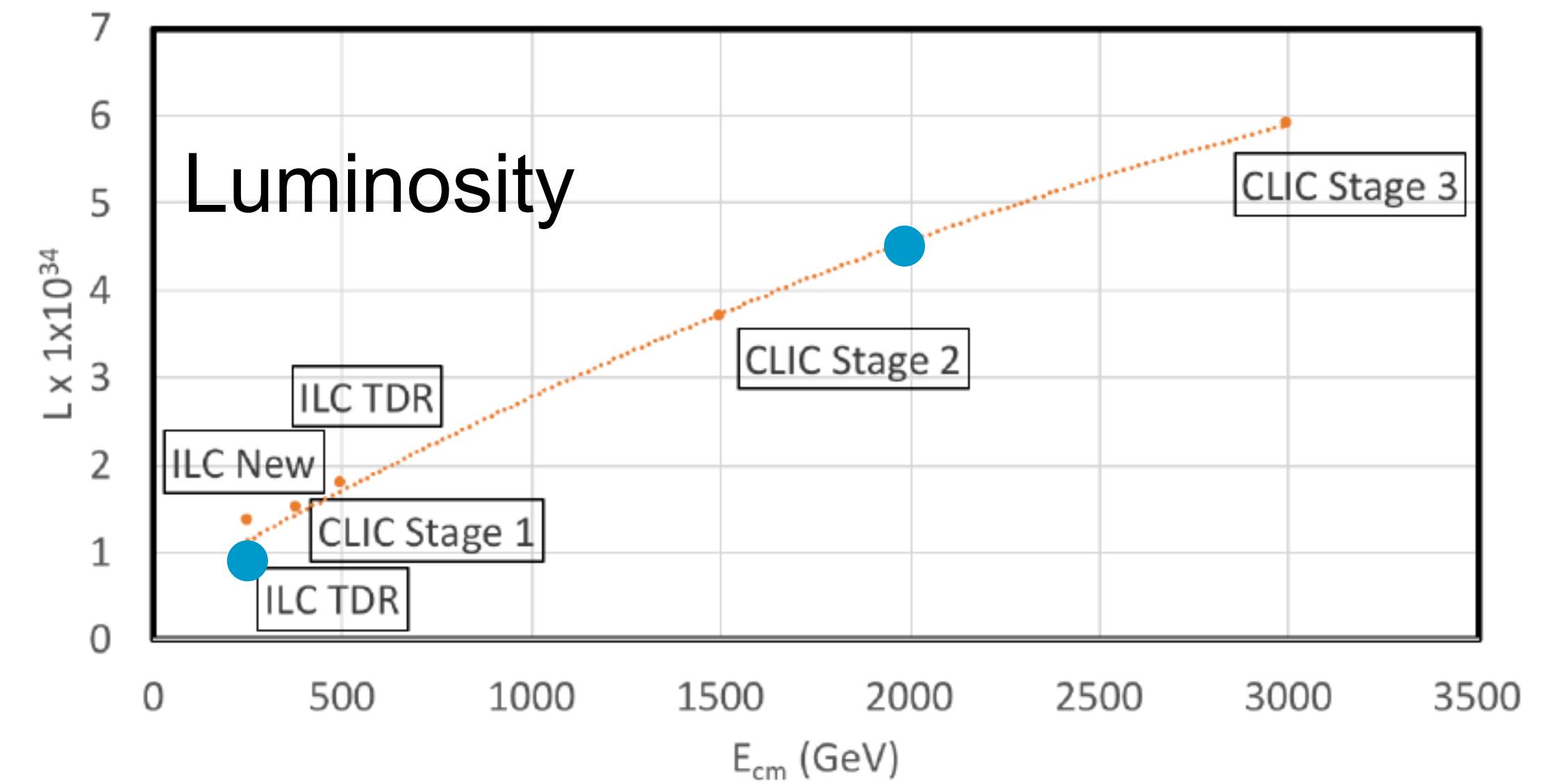

# Rapid Construction with a Surface Site

- “Cut and cover” construction
- Precast concrete housing elements made on site
- Limited waster material – reuse material to cover tunnel
- Requires low density site e.g. Hanford

First level precast elements installation

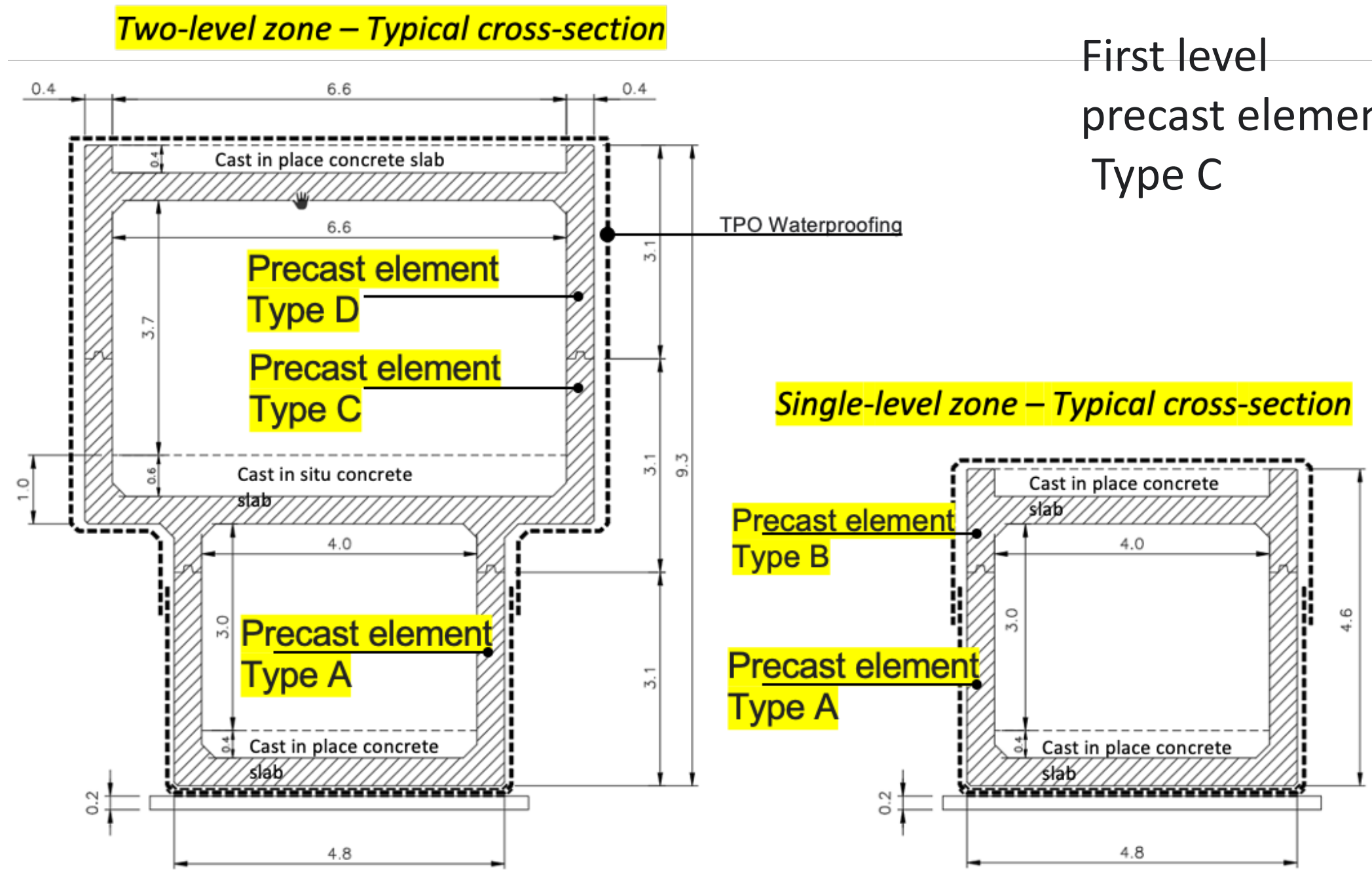
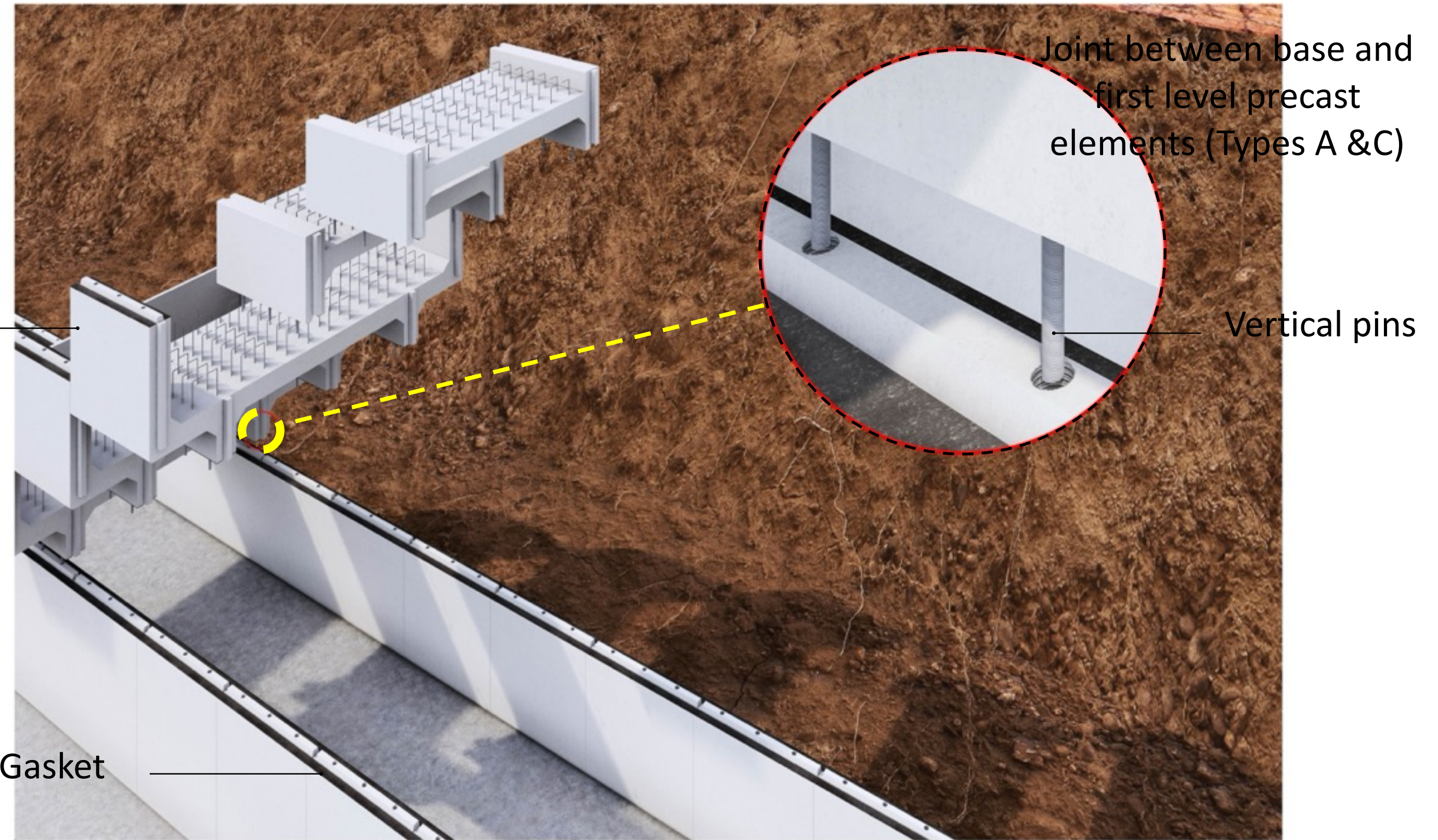

# Power Consumption and Sustainability

Snowmass

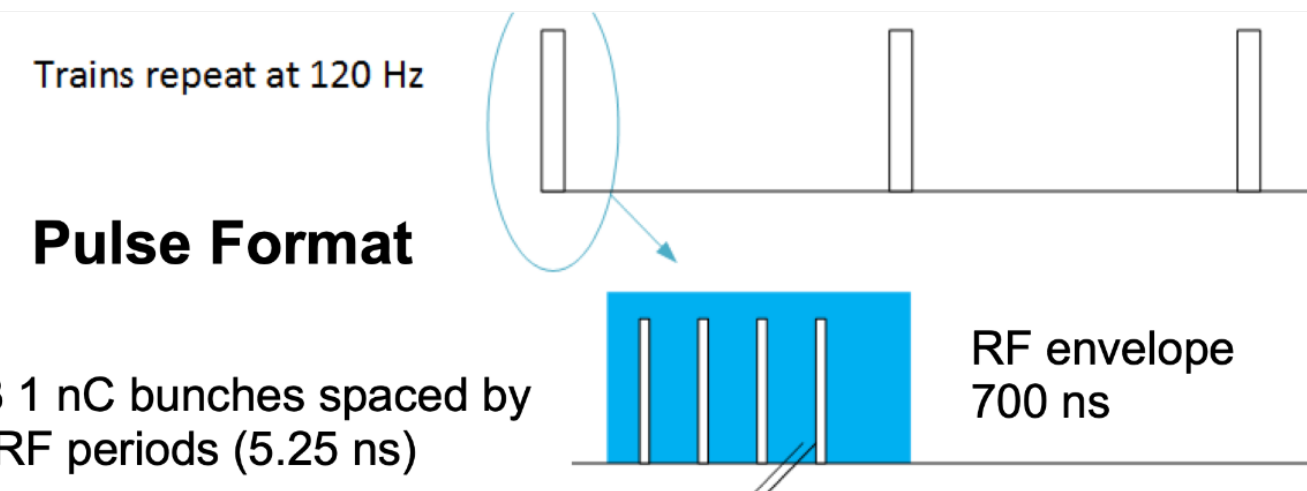

<b>Temperature (K)</b>	<b>77</b>
<b>Beam Loading (%)</b>	<b>45</b>
<b>Gradient (MeV/m)</b>	<b>70</b>
<b>Flat Top Pulse Length (<math>\mu\text{s}</math>)</b>	<b>0.7</b>
<b>Cryogenic Load (MW)</b>	<b>9</b>
<b>Main Linac Electrical Load (MW)</b>	<b>100</b>
<b>Site Power (MW)</b>	<b>~150</b>

**250 GeV CoM - Luminosity -  $1.3 \times 10^{34}$**

<b>Parameter</b>	<b>Units</b>	<b>Value</b>
<b>Reliquification Plant Cost</b>	<b>M\$/MW</b>	<b>18</b>
<b>Single Beam Power (125 GeV linac)</b>	<b>MW</b>	<b>2</b>
<b>Total Beam Power</b>	<b>MW</b>	<b>4</b>
<b>Total RF Power</b>	<b>MW</b>	<b>18</b>
<b>Heat Load at Cryogenic Temperature</b>	<b>MW</b>	<b>9</b>
<b>Electrical Power for RF</b>	<b>MW</b>	<b>40</b>
<b>Electrical Power For Cryo-Cooler</b>	<b>MW</b>	<b>60</b>
<b>Accelerator Complex Power</b>	<b>MW</b>	<b>~50</b>
<b>Site Power</b>	<b>MW</b>	<b>~150</b>

**Compatibility with Renewables  
Cryogenic Fluid Energy Storage**



Intermittent and variable power production from renewables mediated with commercial scale energy storage and power production