

Distributed Imaging System for MAGIS-100

Magnetic Field Effects of DIS

Sanha Cheong

Aug. 5th, 2023



Magnetic Field Concerns for DIS

DIS lenses have **nominal working distance of 60mm**

- **Closest items** to the center of the chamber and therefore atom trajectories
- **Target magnetic field noise level of ~1mG** (desired by Jason, et al.)

On Aug. 2nd, Yijun helped us measure the magnetic fields with the DIS lenses roughly at this distance

- Tested with lens only as well as lens + camera (no power on)
 - Current through the electronics not expected to be significant
(no AC component)
- Lens is brought from far distance → 60mm distance from 3 different directions
- **Very rough, preliminary measurements showed O(1mG) magnetic field**
⇒ More investigation is needed!
 - Measure more precisely/systematically
 - Identify exact components that cause B-field

Test Lens
Orientation 1

Test Lens
Orientation 2

Magnetometer

Test Lens
Orientation 3

Progress from Last Friday (2023/08/04)

- Wrote some code to live-monitor magnetometer measurements
- **Experiment protocol**
 - Start with no objects near the magnetometer
 - Record for 10s
 - Bring test object to the relevant test distance
 - Record for 10s
 - Repeat for 1 minute
 - 3 × 10s of “background” run, 3 × 10s of “signal” run
- **Analysis**
 - Significant periodic noise at ~1Hz ⇒ low-pass filter with $f_{\text{threshold}} = 0.5 \text{ Hz}$
 - Compare the mean over “background” regions v.s. the mean over “signal” regions
 - $B_{\text{sig}} - B_{\text{bkg}}$ is reported for each component with statistical uncertainty
 - Systematics not accounted, e.g. error in my hand placing the object at the exact location consistently
- **Goal:**
 - **Reproduce / Improve magnetic field measurements**
 - **Identify each component’s contribution**

A Note on Experimental Set-up

- Model 534 Fluxgate Magnetometer by Applied Physics Systems
 - Actual sensor chip is not point-like
 - The exact location is somewhat unclear
- **Therefore, chose a somewhat conservative “center” as reference**
 - Distances measured from this reference point
 - Might not be representative of where the sensor is
- If the reference point is reasonable, the magnitude of B-field should be similar regardless of orientation
 - If not, it hints at the discrepancy between real sensor location v.s. our reference point
- **Distance measurement is not super-precise**
 - Hard to measure distance in free space
 - Inconsistency in my hand placing the object
 - **This systematic is probably somewhat significant, so don't take the statistical uncertainties too literally**

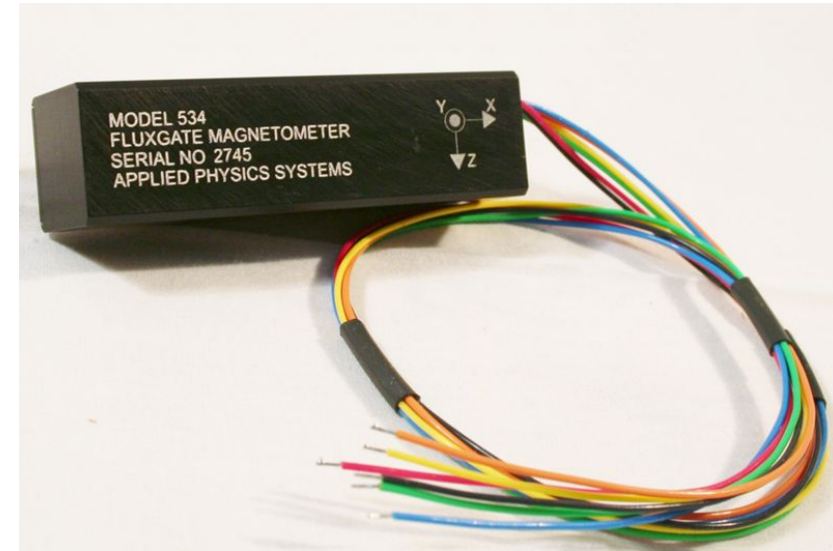

Example Analysis

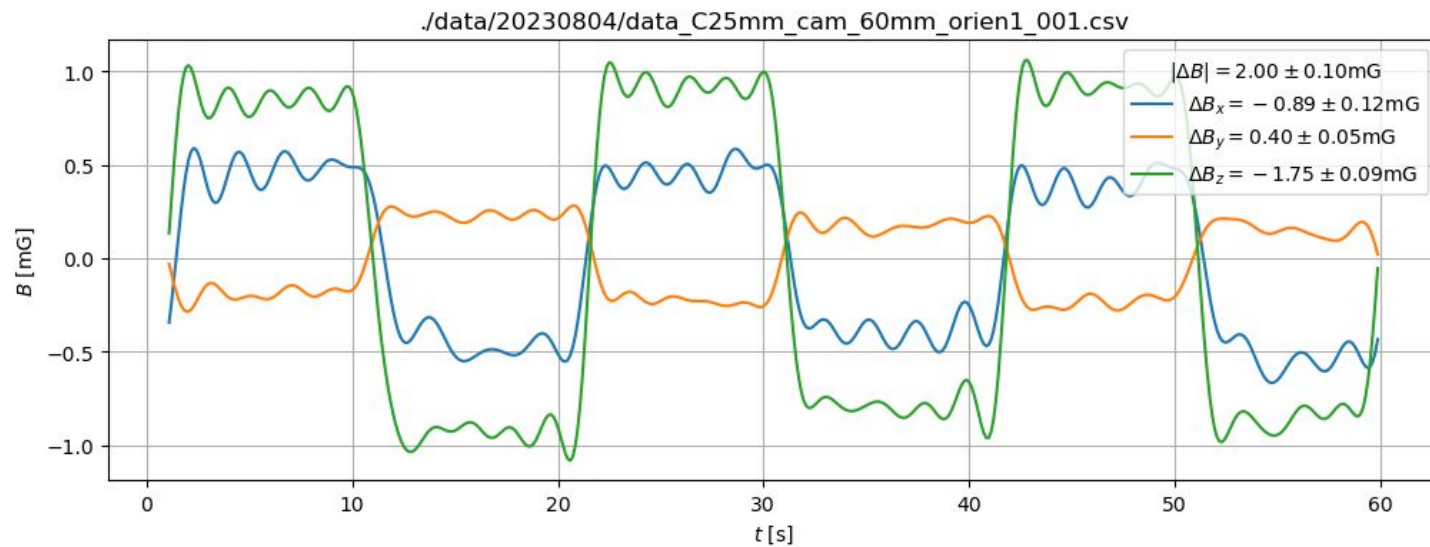
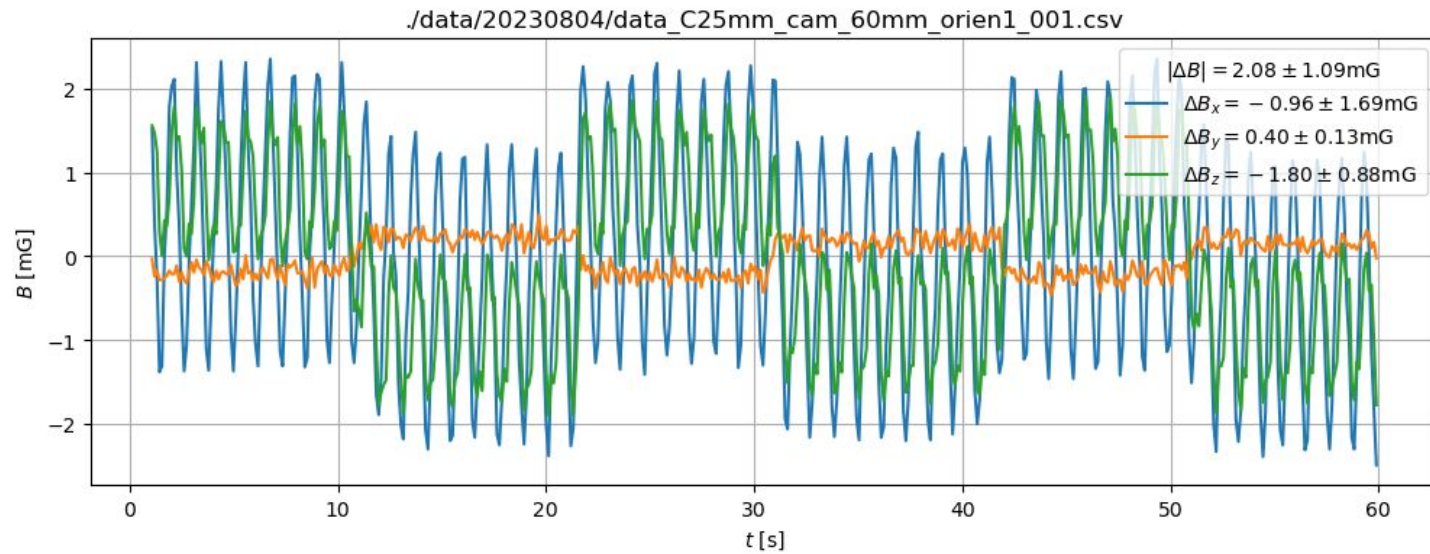

Low-pass filter
+ bkg. v.s. sig.
comparison

Nominal Camera Only (BFS-50S4M-C, No Power)

- Camera placed at positions roughly corresponding to nominal WD (60mm to lens) and nominal WD + 10mm (70mm to lens)
- The actual sensor is probably much closer to orientation 2 (i.e. at orientation 2, object-sensor distance is much less than 60mm)
- $|\Delta B|$ around 0.5mG @ 60mm, 0.4mG @ 70mm
- Main take-away: camera alone contributes ~0.5mG

Test Object	Object Orientation	Working Distance	ΔB_x [mG]	ΔB_y [mG]	ΔB_z [mG]	$ \Delta B $ [mG]
Only 50S4M Camera (no power)	1	60mm	0.02 ± 0.11	0.12 ± 0.08	-0.57 ± 0.09	0.59 ± 0.09
		70mm	-0.01 ± 0.08	0.09 ± 0.05	-0.53 ± 0.06	0.53 ± 0.06
	2	60mm	-0.62 ± 0.09	0.13 ± 0.03	-0.01 ± 0.06	0.64 ± 0.08
		70mm	-0.47 ± 0.07	0.09 ± 0.05	-0.05 ± 0.08	0.49 ± 0.07
	3	60mm	-0.08 ± 0.08	0.09 ± 0.03	0.44 ± 0.10	0.45 ± 0.10
		70mm	0.02 ± 0.09	0.12 ± 0.04	0.16 ± 0.05	0.20 ± 0.05

Nominal HM Lens (C-series 25mm) + Camera (No Power)

- Lens + camera placed at roughly 60mm & 70mm working distances
- The actual sensor is probably much closer to orientation 2
(i.e. at orientation 2, object-sensor distance is much less than 60mm)
- $|\Delta B|$ around **1.6mG @ 60mm, 1.1mG @ 70mm**
- **Main take-away: HM lens + camera create $B > 1$ mG**

Test Object	Object Orientation	Working Distance	ΔB_x [mG]	ΔB_y [mG]	ΔB_z [mG]	$ \Delta B $ [mG]
C-series 25mm Lens + 50S4M Camera (no power)	1	60mm	1.40 ± 0.12	-0.24 ± 0.05	0.88 ± 0.08	1.67 ± 0.11
		70mm	0.94 ± 0.10	-0.20 ± 0.04	0.51 ± 0.09	1.09 ± 0.10
	2	60mm	-0.78 ± 0.13	-0.47 ± 0.04	-3.56 ± 0.16	3.68 ± 0.16
		70mm	-0.22 ± 0.09	0.43 ± 0.04	2.65 ± 0.17	2.69 ± 0.16
	3	60mm	-1.20 ± 0.12	-0.31 ± 0.07	0.73 ± 0.20	1.44 ± 0.14
		70mm	-0.84 ± 0.11	-0.17 ± 0.05	0.53 ± 0.17	1.01 ± 0.13

Nominal LM Lens (C-series 8.5mm) + Camera (No Power)

- Lens + camera placed at roughly 60mm & 70mm working distances
- The actual sensor is probably much closer to orientation 2
(i.e. at orientation 2, object-sensor distance is much less than 60mm)
- $|\Delta B|$ around 0.7mG @ 60mm, 0.6mG @ 70mm
- Main take-away: LM lens + camera create $B \sim 0.7$ mG—LM lens effect must be small

Test Object	Object Orientation	Working Distance	ΔB_x [mG]	ΔB_y [mG]	ΔB_z [mG]	$ \Delta B $ [mG]
C-series 8.5mm Lens + 50S4M Camera (no power)	1	60mm	0.32 ± 0.11	-0.49 ± 0.04	-0.20 ± 0.07	0.62 ± 0.07
		70mm	0.21 ± 0.15	-0.39 ± 0.05	-0.24 ± 0.08	0.51 ± 0.08
	2	60mm	-0.63 ± 0.09	-0.84 ± 0.05	-0.68 ± 0.09	1.25 ± 0.07
		70mm	-0.51 ± 0.09	-0.61 ± 0.05	-0.48 ± 0.10	0.93 ± 0.08
	3	60mm	-0.06 ± 0.08	-0.65 ± 0.04	0.53 ± 0.07	0.84 ± 0.06
		70mm	-0.10 ± 0.11	-0.52 ± 0.06	0.53 ± 0.14	0.75 ± 0.11

Summary of Nominal Design

- Orientation 2 data excluded (since objects are most likely too close)
- Data from orientations 1 and 2 + their weighted average
- **Main take-aways:**
 - **Camera alone creates ~0.5mG**
 - This is more-or-less the lower bound, unless there is some lucky cancellation of B_{lens} and B_{camera}
 - **Simply pushing the current nominal system to WD = 70mm isn't good enough, due to HM lens**
- Remaining questions / concerns:
 - Cameras have not been tested with power on—are we at all worried about current through the cameras?
 - **What is the exact source of the lens magnetic field?**

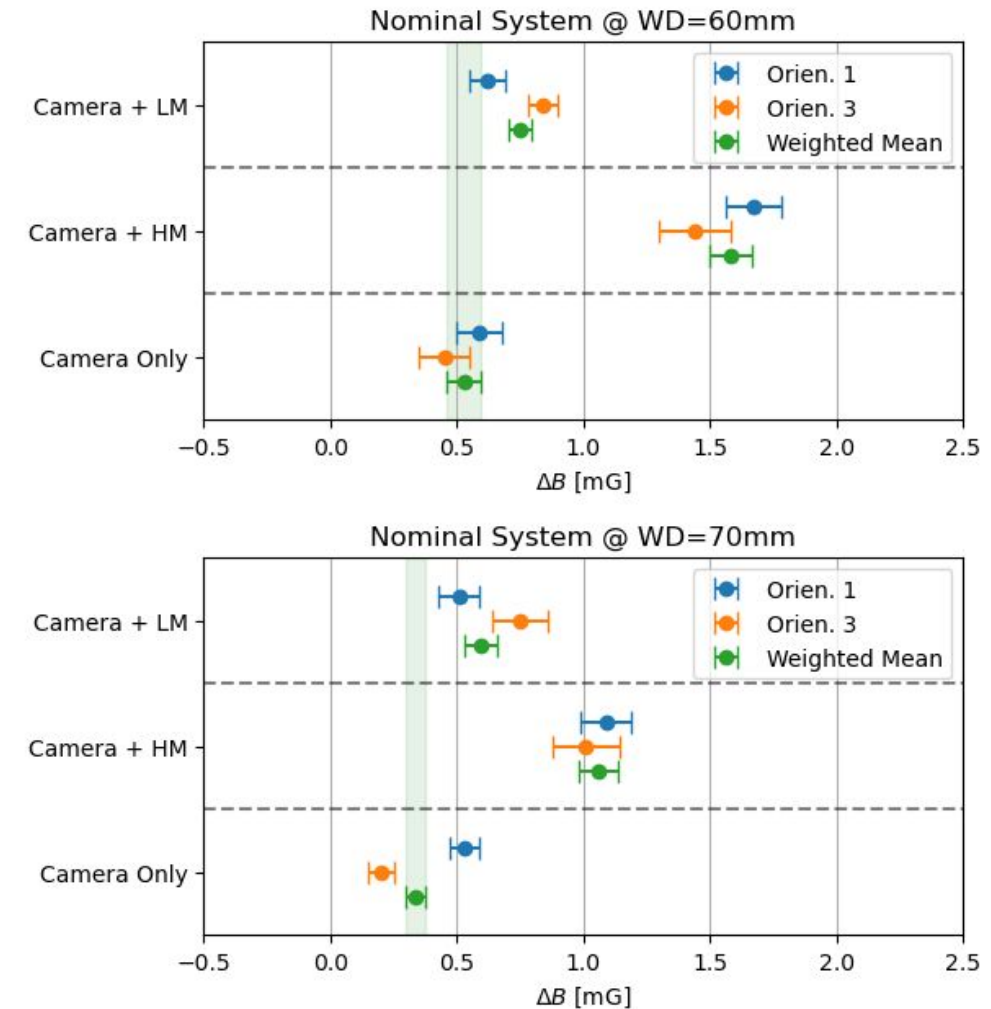

Investigating Source of Lens Magnetic Field

What is the source of these magnetic fields?

- **Materials within the lens** (according to Kasia Sieluzycka, Edmund Optics Engineer)
 - Main barrel, lens cells, spacers, retainers:
Aluminum 6061-T6 with Matte Black Anodize per MIL-A-8625 Type II, Class 2
 - Some pins and screws and compression spring
Stainless Steel Y1Cr18Ni9 or substitute 1Cr118Ni9
 - Set screws
Steel 20 (ANSI 1020) with black anodize or black oxide finish
 - **Iris leaves**
Precision Strip Steel, grade Eberle 18, hardened, tempered, unpolished or equivalent substitute Alloy tool steel **CrO3**
- **Iris leaves are the largest component in the lens that might not clearly steel / aluminium**
- **Jason tried a different, but similar-looking iris leaf near the magnetometer ⇒ Very magnetic!!!**
(Huge thanks for staying around until late to test this together!)

Non-magnetic Alternatives for DIS Lenses



- **Ci-series alternatives**
 - “Instrumentation” versions with the same optics, but less fasteners, no iris, etc.
- We have ordered a couple of them for testing
 - Ci-series, f/2.8, 25mm as HM alternative
 - Ci-series, f/1.8, 8.5mm as LM alternative
- Caveat: no iris \Rightarrow fixed f/# \Rightarrow We need to decide on f/# working point before purchasing

Alternative HM Lens (Ci-series 25mm, f/2.8) + Camera (No Power)

- Lens + camera placed at roughly 60mm & 70mm working distances
- The actual sensor is probably much closer to orientation 2
(i.e. at orientation 2, object-sensor distance is much less than 60mm)
- **$|\Delta B|$ around 0.5mG @ 60mm, 0.3mG @ 70mm**
 - **Basically camera-only effects**

Test Object	Object Orientation	Working Distance	ΔB_x [mG]	ΔB_y [mG]	ΔB_z [mG]	$ \Delta B $ [mG]
Ci-series 25mm Lens + 50S4M Camera (no power)	1	60mm	0.27 ± 0.22	0.12 ± 0.05	-0.54 ± 0.19	0.61 ± 0.29
		70mm	0.04 ± 0.16	0.10 ± 0.06	-0.26 ± 0.17	0.28 ± 0.24
	2	60mm	-0.55 ± 0.10	0.13 ± 0.03	0.11 ± 0.09	0.58 ± 0.14
		70mm	-0.41 ± 0.12	0.13 ± 0.03	-0.02 ± 0.16	0.43 ± 0.21
	3	60mm	-0.00 ± 0.09	0.14 ± 0.04	0.39 ± 0.14	0.42 ± 0.17
		70mm	-0.05 ± 0.09	0.13 ± 0.04	0.28 ± 0.16	0.32 ± 0.19

Alternative LM Lens (Ci-series 8.5mm, f/1.8) + Camera (No Power)

- Lens + camera placed at roughly 60mm & 70mm working distances
- The actual sensor is probably much closer to orientation 2
(i.e. at orientation 2, object-sensor distance is much less than 60mm)
- **$|\Delta B|$ around 0.6mG @ 60mm, 0.4mG @ 70mm**
 - **Basically camera-only effects**

Test Object	Object Orientation	Working Distance	ΔB_x [mG]	ΔB_y [mG]	ΔB_z [mG]	$ \Delta B $ [mG]
C-series 8.5mm Lens + 50S4M Camera (no power)	1	60mm	0.05 ± 0.09	0.08 ± 0.05	-0.66 ± 0.08	0.66 ± 0.08
		70mm	-0.09 ± 0.12	0.07 ± 0.03	-0.48 ± 0.08	0.49 ± 0.08
	2	60mm	-0.67 ± 0.07	0.15 ± 0.05	0.09 ± 0.08	0.69 ± 0.07
		70mm	-0.56 ± 0.09	0.11 ± 0.04	0.04 ± 0.08	0.57 ± 0.09
	3	60mm	0.03 ± 0.16	0.16 ± 0.11	0.44 ± 0.13	0.47 ± 0.12
		70mm	-0.10 ± 0.10	0.09 ± 0.05	0.35 ± 0.17	0.38 ± 0.16

Comparisons of Different Lenses

- **Lens only, no camera**
- Lens placed at roughly 60mm along orientation 1
- C-series B -field may seem larger compared to lens + camera, but this is probably due to lucky cancellations in $B_{\text{lens}} + B_{\text{camera}}$
- **$|\Delta B|$ around 1 - 2 mG for C-series lenses, but basically 0mG for Ci-series**

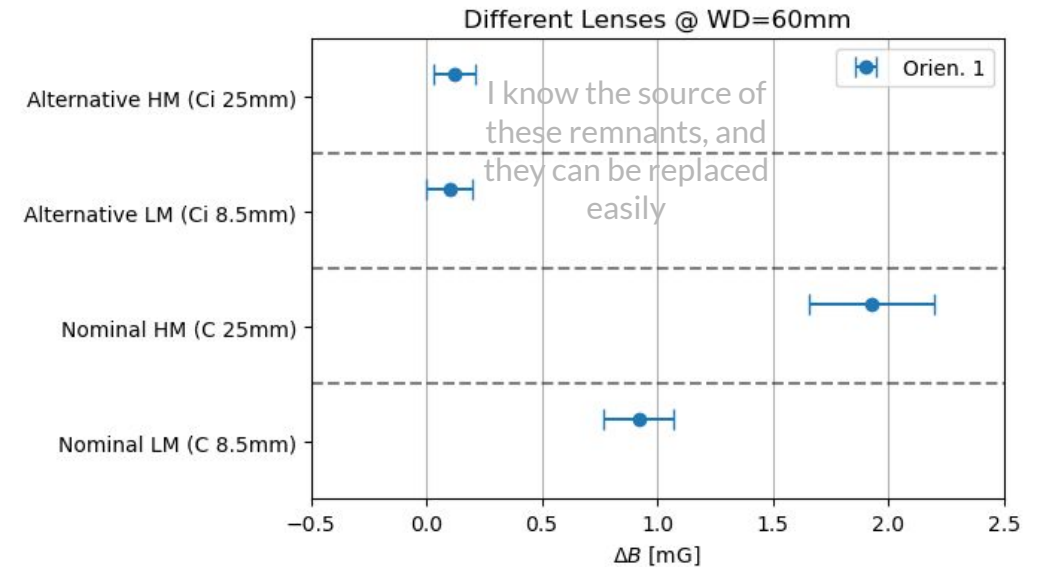

Test Object	Object Orientation	Working Distance	ΔB_x [mG]	ΔB_y [mG]	ΔB_z [mG]	$ \Delta B $ [mG]
C-series 8.5mm Lens	1	60mm	0.80 ± 0.15	0.42 ± 0.15	0.14 ± 0.07	0.92 ± 0.15
C-series 25mm Lens			-1.92 ± 0.27	0.08 ± 0.07	-0.17 ± 0.13	1.93 ± 0.27
Ci-series 8.5mm Lens			-0.08 ± 0.09	0.03 ± 0.04	-0.06 ± 0.11	0.10 ± 0.10
Ci-series 25mm Lens			-0.10 ± 0.10	-0.05 ± 0.05	0.04 ± 0.07	0.12 ± 0.09

Summary of Nominal v.s. Alternative

- Mainly comparing C-series v.s. Ci-series
- Main take-aways:
 - Camera alone creates $\sim 0.5\text{mG}$, which is more-or-less the lower bound
 - Ci-series lenses are non-magnetic, basically leaving camera B -field only

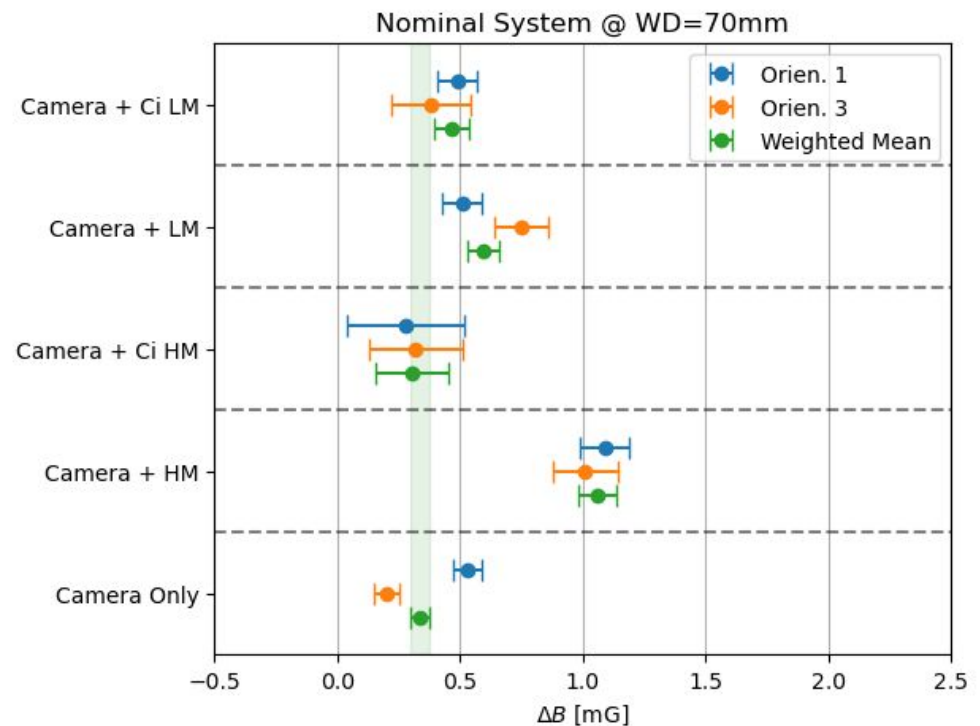
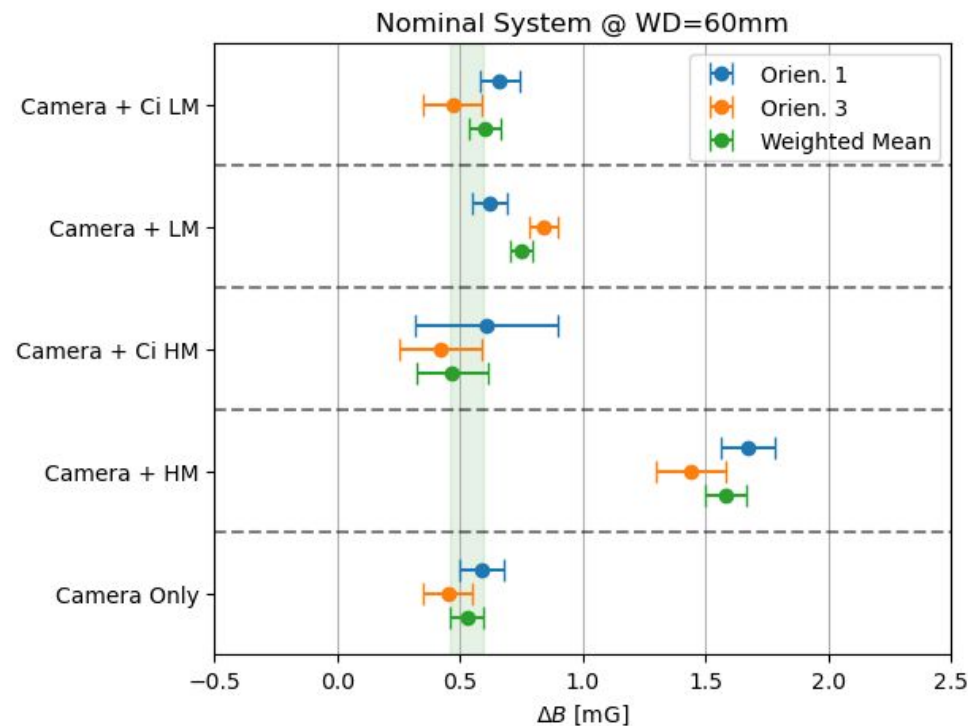

Summary / Discussion Points

Summary

- Overall B -field for nominal design is 1 - 2 mG (camera ~ 0.5 mG, LM lens ~ 1 mG, HM lens > 1 mG)
- **The main culprit seems to be the camera itself and the iris leaves in the lenses**
- Replacing with iris-less, Ci-series lens basically removes lens effects
⇒ **We are bound below by the camera**, 0.5mG @ WD = 60mm, 0.4mG @ WD = 70mm

Questions

- **How strictly should we respect the 1mG target?**
 - Was this a rough estimate? Was it on the conservative side?
 - Jason: “There may be some magnetic field due to ion pumps and other idiosyncrasies. DIS might not be the big culprit on top of those.”
- **Cameras tested without power. Should I re-test them with power on?**
- **How do we feel about 0.5mG or 0.4mG due to the cameras. Happy?**
 - If not, we could consider board-level cameras, but no guarantee that these will be better
- Are we ready to commit to specific $f/\#$ and purchase the iris-less, Ci-series lenses?

Strategies

- **Is degaussing still an option?**
 - Exposing camera electronics under large B -field doesn't seem like the best idea to me
- C-series lenses but with iris material specified to be non-magnetic (this will give $f/\#$ flexibility)

DIS for MAGIS-100

Back-up Slides

Single Imaging Node

- 3 cameras at each of 14 nodes
- 2 × Low-Magnification (LM) + 1 High-Magnification (HM)
 - 2 LM provide 3D positioning, HM for physics

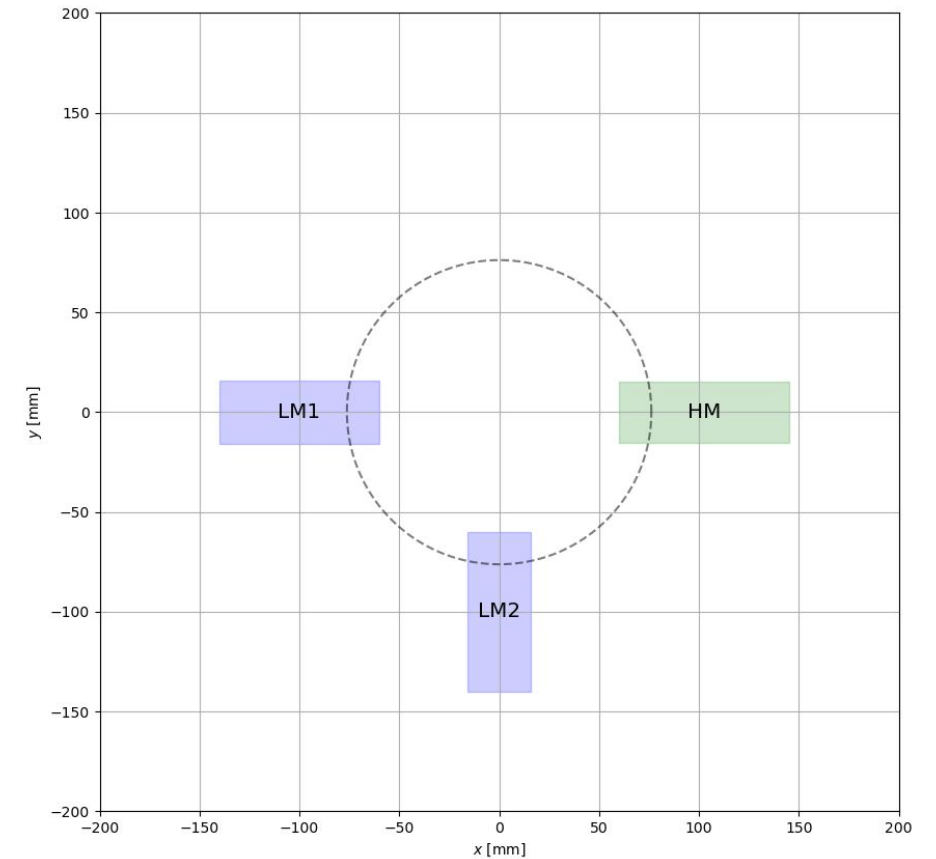
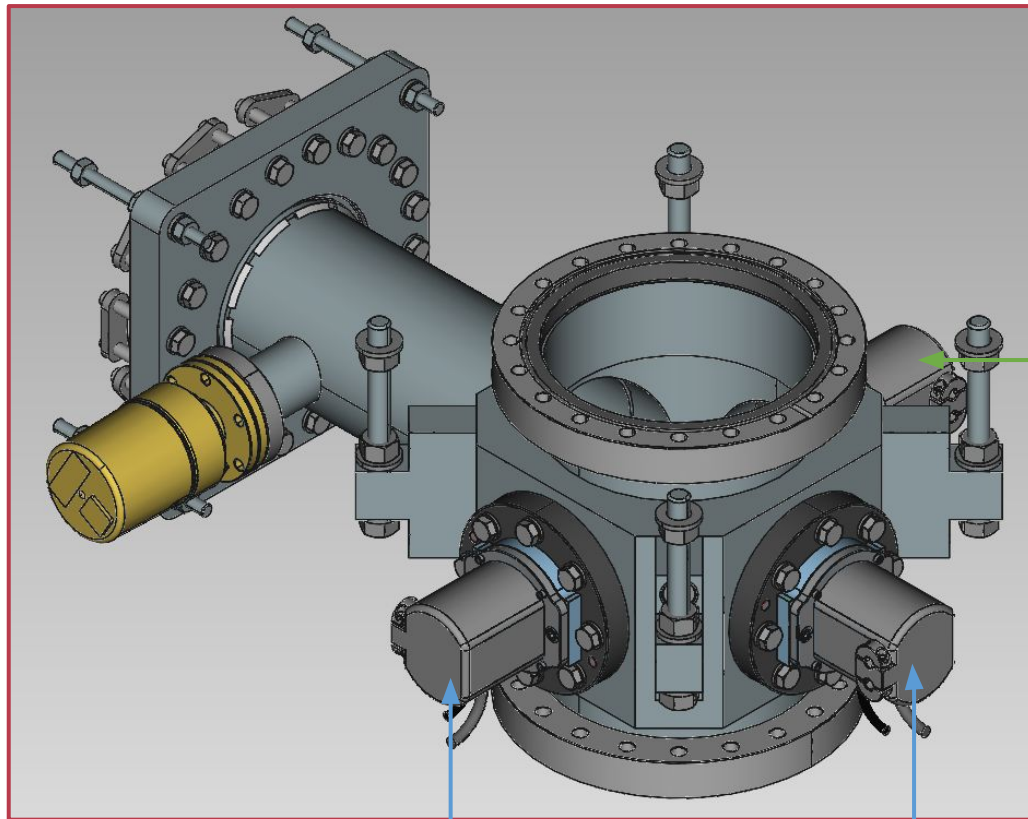

HM System

LM Systems

Lenses

- **Low-magnification (LM) lens choice: final, [link](#)**
 - 8.5mm lens, $m = 0.1$ @ WD = 60mm with 0.5mm extension
 - Large field-of-view (FoV), but distortion could be significant at edges
 - Expected cost: $\$343 \times 0.95 \times 2 \times 16 = \$10,427.20$
- **High-magnification (HM) lens choice: basically final, [link](#)**
 - 25mm lens, $m = 0.42$ @ WD = 60mm with 5mm extension
 - Intended to resolve $O(100\mu\text{m})$ features
 - Depth of field (DoF) very sensitive to f-number—exact operating point can be tuned later
 - Question: Where should we land on the DoF / light-collection trade-off plane?
 - Expected cost: $\$326 \times 0.95 \times 16 = \$4,955.20$

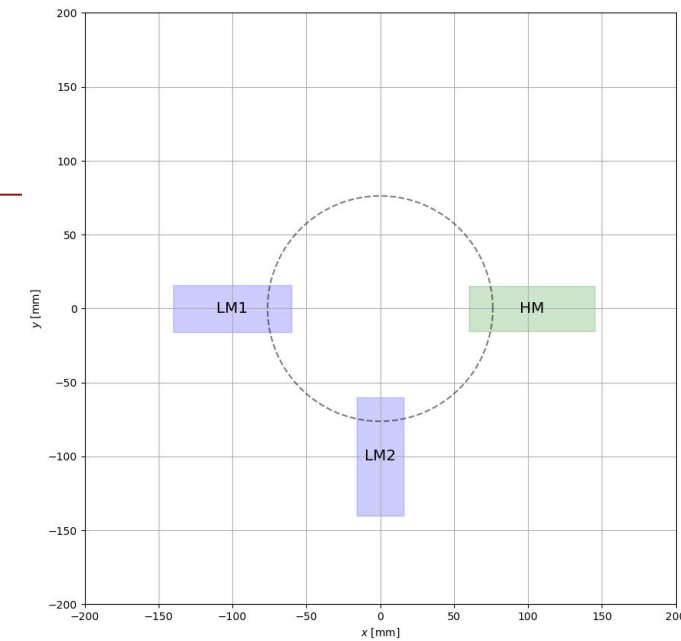

Imaging Node Mechanical Design (1/2)

- 3 re-entrant viewports / connection node
- Imaging module inserts into each viewport, same for LM and HM
- For now, all 14 nodes are identical—maybe small changes depending on RPi box location?

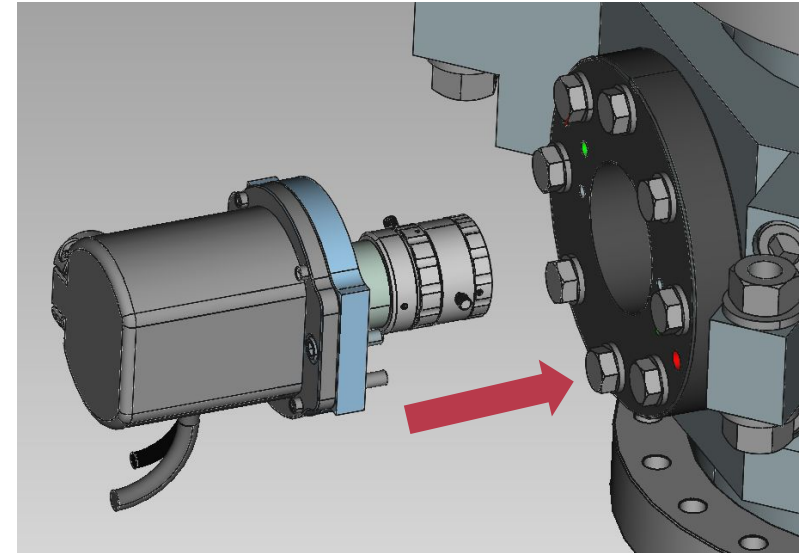
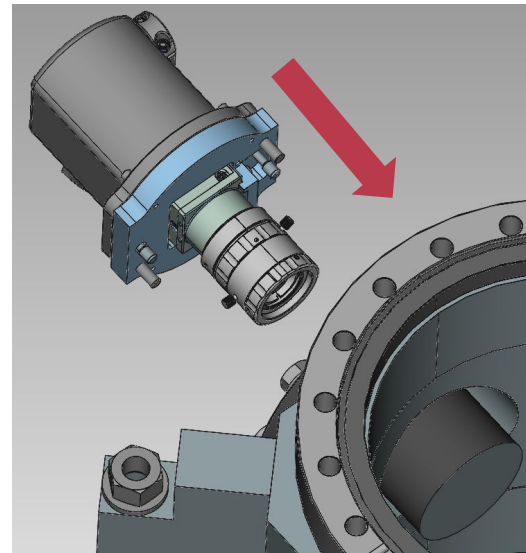
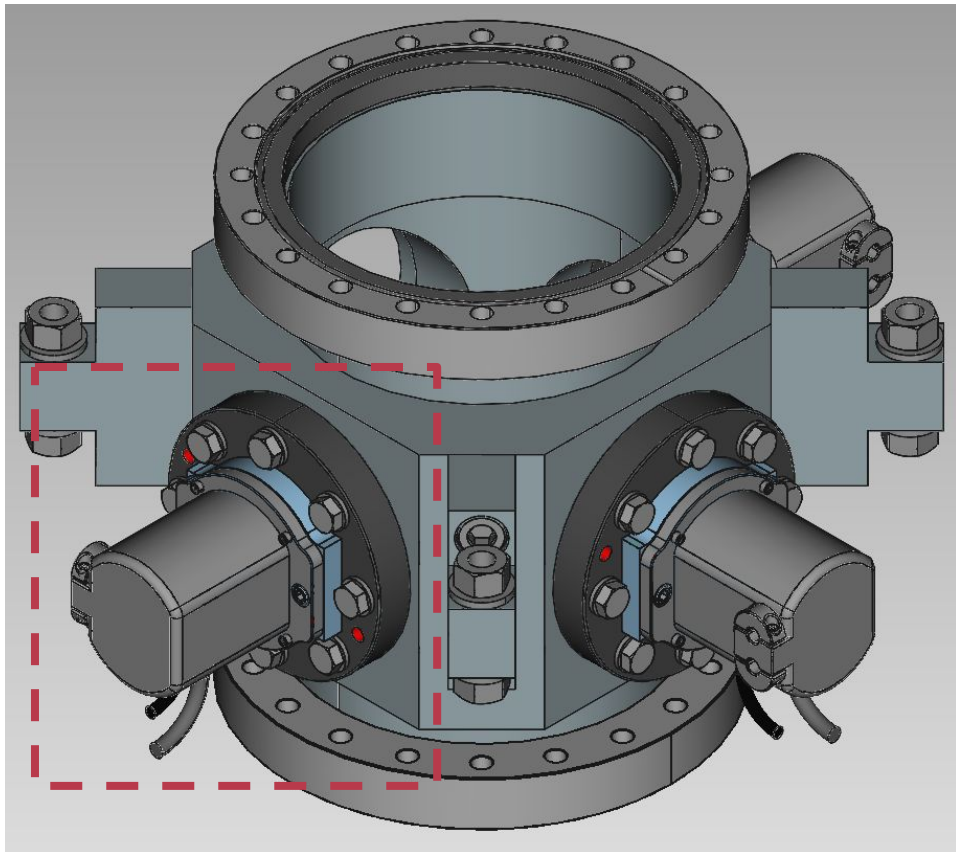

Imaging Node Mechanical Design (2/2)

- HM module shown as an example
 - Clearance similar for LM module
- Camera mounted onto custom plates
 - Mounted “sideways” for large vertical FoV
 - 90deg cables exit towards the bottom
- Compound mounting plate locks into the viewport flange, securing the entire module

