

Translating Near to Far Detector with Deep Learning for DUNE-PRISM

Alex Wilkinson for the DUNE Collaboration

NPML 2023
23 August 2023



DUNE Detectors

- ▶ Far Detector (FD)
 - Multiple 17kt LArTPCs with wire readout
- ▶ Near Detector (ND) complex:
 - ND-LAr
 - Primary LAr target at ND
 - Designed for high intensity neutrino beam — modular optically isolated drift volumes and pixel readout
 - Muon spectrometer (Phase 1) + Gaseous Ar target (Phase 2)
 - System for on-Axis Neutrino Detection (SAND) — beam monitor
 - Precision Reaction Independent Spectrum Measurement (PRISM)
 - ND-LAr + muon spectrometer able to move up to 33m off-axis from beam
 - Sample different fluxes from neutrino beam

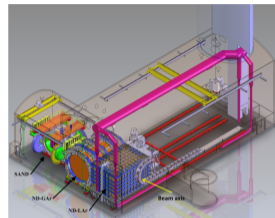

↓ PRISM!

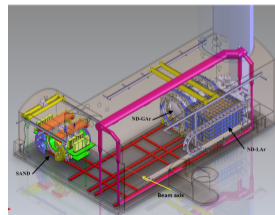

- ▶ ND supports long-baseline oscillation measurements by constraining elements in convolution:

$$N_{\nu}^{near} (E_{rec}) = \int dE_{\nu} \phi_{\nu}^{near} (E_{\nu}) \times \sigma_{\nu}^{Ar} (E_{\nu}) \times D_{\nu}^{near} (E_{\nu}, E_{rec})$$

$$N_{\nu}^{far} (E_{rec}) = \int dE_{\nu} P_{osc} (E_{\nu} | \theta) \times \phi_{\nu}^{far} (E_{\nu}) \times \sigma_{\nu}^{Ar} (E_{\nu}) \times D_{\nu}^{far} (E_{\nu}, E_{rec})$$

- ▶ PRISM allows for ND measurements at different fluxes

→ Helps break degeneracies in fitting simulation to data from a single observation

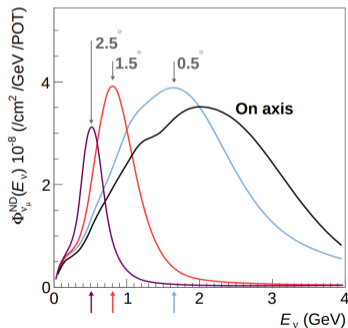

PRISM Linear Combination

- Off-axis positions can be linearly combined to approximate a target FD oscillated flux from ND measurements

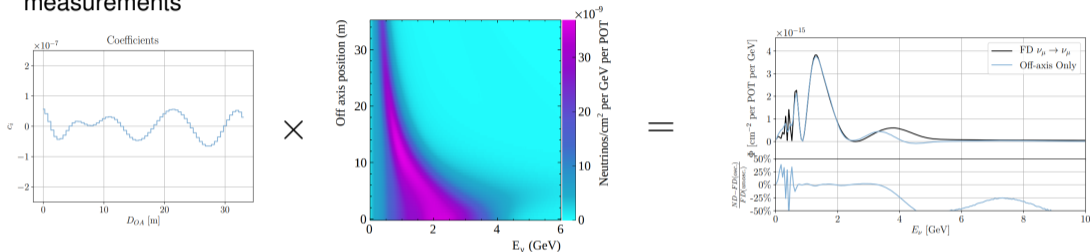

- "PRISM style" oscillation analysis:

→ Calculate weights \mathbf{c} for an oscillation hypothesis

$$\phi_\nu^{near}(E_\nu, x_{OA}) \times \mathbf{c} = \phi_\nu^{far}(E_\nu) P_{osc}(E_\nu | \theta)$$

→ Multiply ND data by weights to get ND measurement in FD oscillated flux

→ Extrapolate to FD to get data-driven FD prediction

→ Compare with FD data to get likelihood of oscillation hypothesis

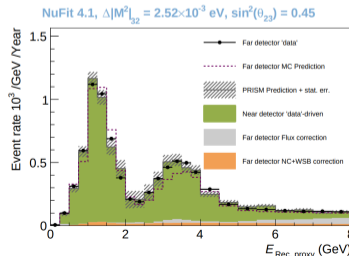

Translating from Near to Far

- ▶ Producing FD prediction from ND measurements in oscillated flux requires correcting for backgrounds, selection, and resolution
 - Data-driven methods for backgrounds and for selection due to containment under development
 - Still need to understand differences in energy resolution and neutrino flavour identification
- ▶ Apply machine learning by treating ND and FD detector response as images from two domains of detector technology
- ▶ Initial focus on translating events contained in ND-LAr
- ▶ Complete translation requires:
 - Inflling non-active regions between ND drift modules (later slides)
 - Incorporate muon spectrometer reconstruction

Near Detector

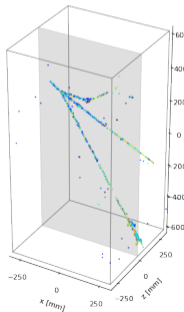

Far Detector

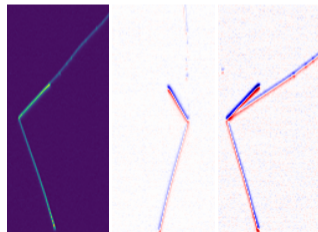

Generating Paired Data

- ▶ Generate paired data by simulating the same charge depositions at both detectors
- ▶ Put pairs into same coordinate system by projecting each 3D ND pixel response onto a wire and time for each wire plane

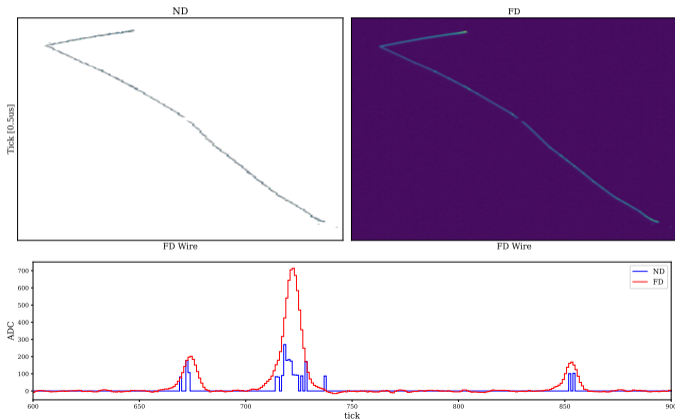
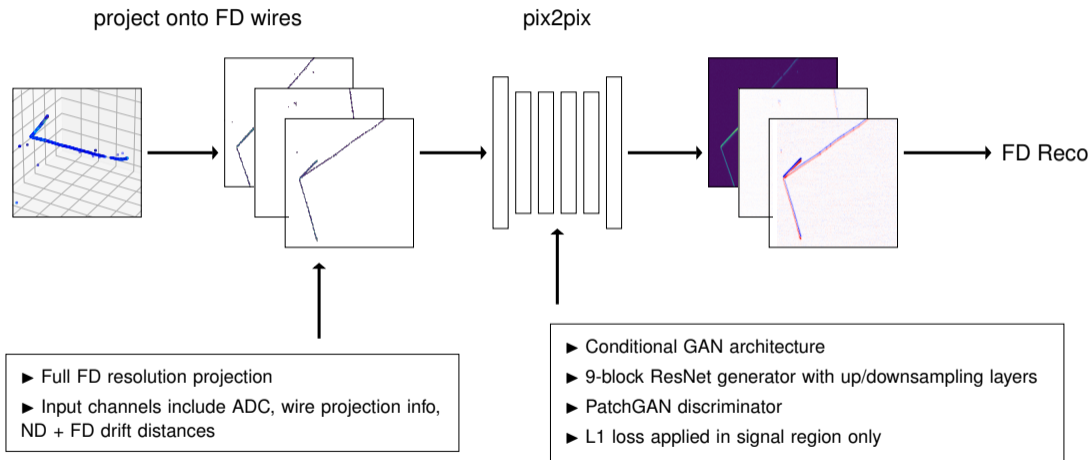
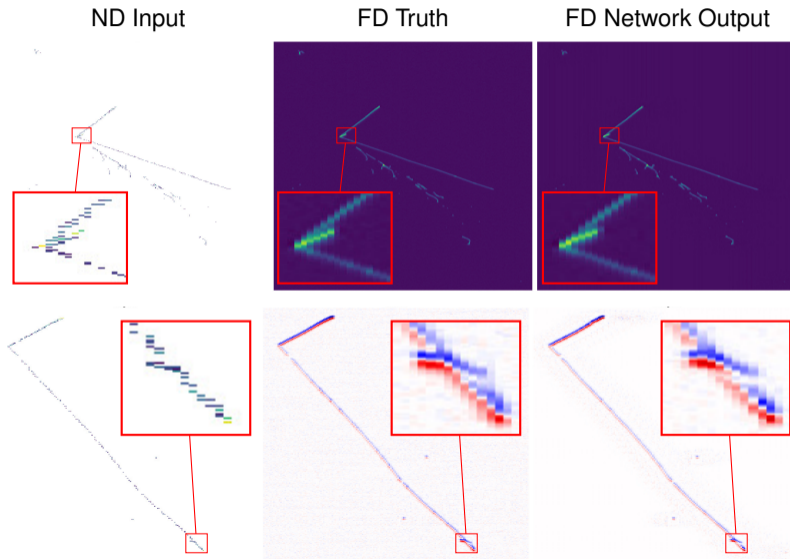

Image-to-Image Translation w/ pix2pix



Results - Image Translation



Results - Wire Trace

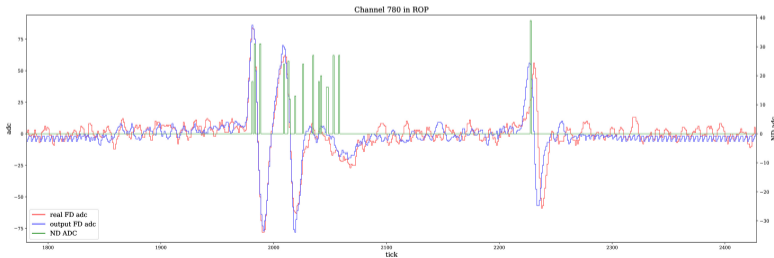
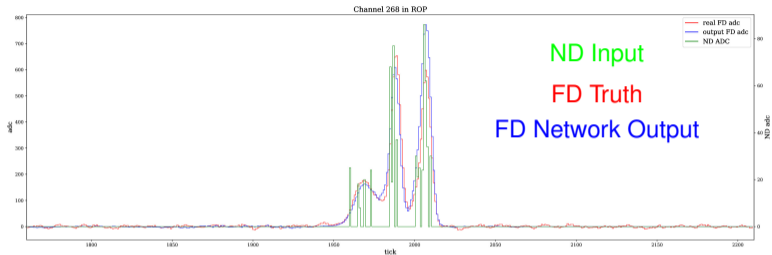

- ▶ Use torchscript + libtorch to import trained model into C++ to use in FD simulation chain
- ▶ Generate analysis files for ND events with predicted FD reconstruction from network
 - And "true" FD reco from resimulating charge depositions at FD
- ▶ Key reco variables:
 - CVN scores: CNN acting on hits to classify neutrino flavour
 - Reconstructed neutrino energy: calorimetric energy reconstruction

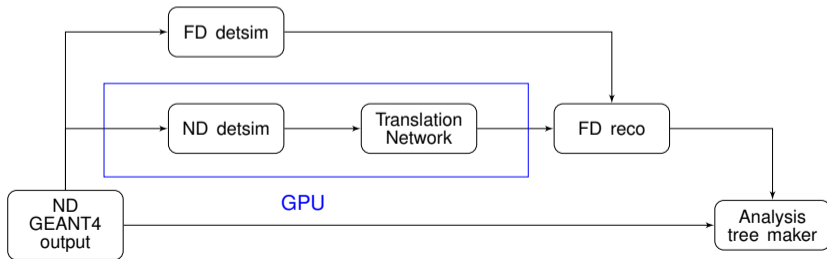

CVN scores

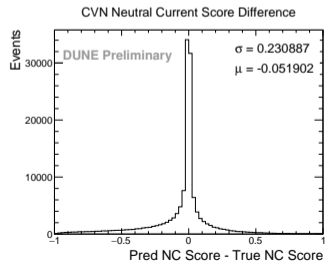
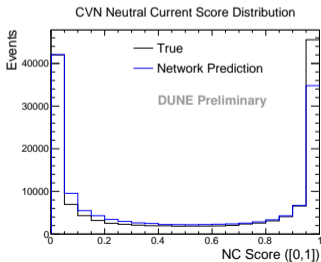
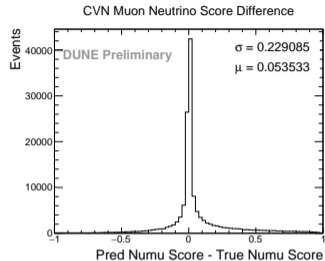
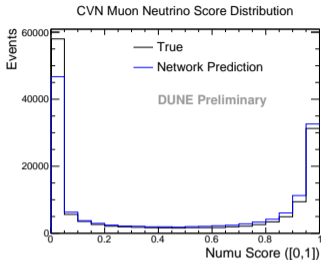

Reconstructed Energy

Reco Neutrino Energy Distribution

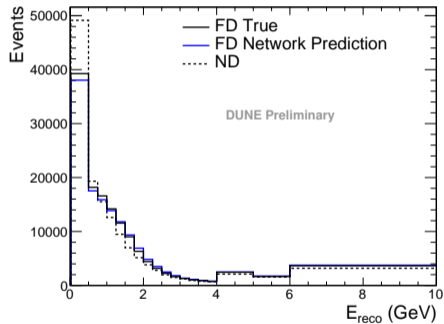

Reco Neutrino Energy Fractional Difference

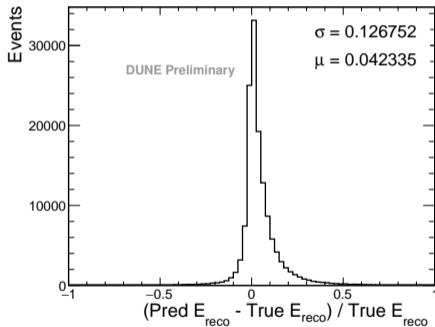

Cross Section Systematics

- ▶ Consider uncertainty in network predicted FD reconstructed energy due to cross section systematics using event reweighting
 - Compare with smearing matrix approach — using MC to unfold $E_{rec}^{ND} \rightarrow E_\nu$ and smear $E_\nu \rightarrow E_{rec}^{FD}$
- ▶ Want cross section systematics to cancel between prediction and data
 - Look at ratio of FD predicted spectra with true FD spectrum under systematic reweights

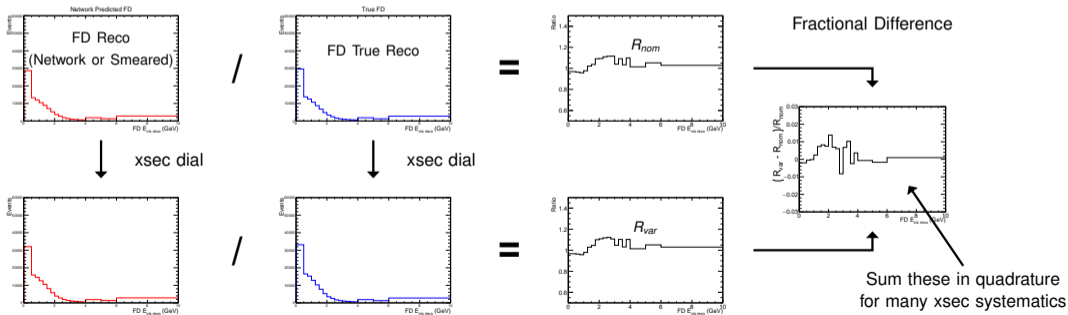

Results - Cross Section Reweighting

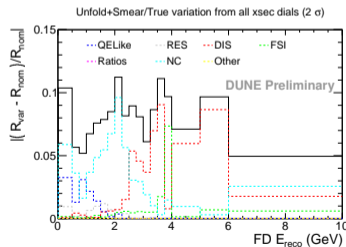
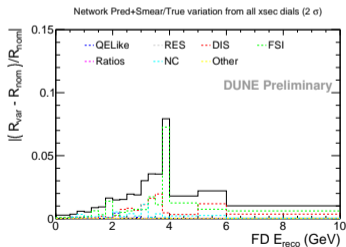
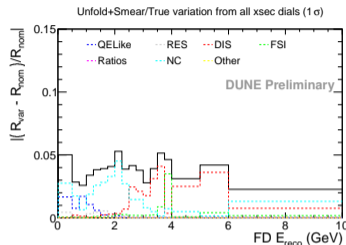
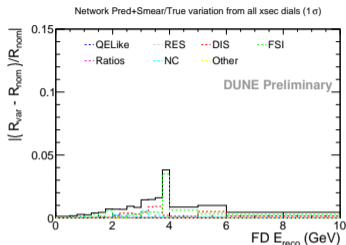

Translation network models difference in $E_\nu \rightarrow E_{rec}$ between near and far much better than smearing

- ▶ Time to face a caveat — need to predict FD detector response in the non-active ND regions between drift modules to correctly translate
- ▶ Difficult to do this after wire projections since positions of gaps are not well defined in this projection
- ▶ Attempt to infill gaps between drift modules at the 3D pixel response level

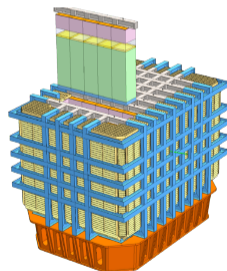
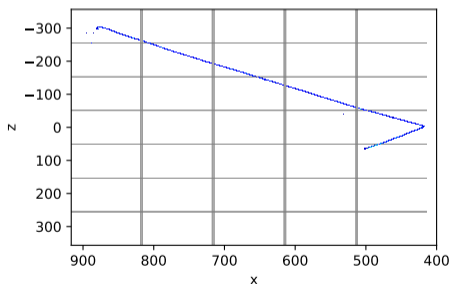

- ▶ Consider generating detector response in the non-active region as an inpainting problem in 3D
- ▶ Voxelised ND-LAr has size $\mathcal{O}(10^9)$ — need to use sparse tensors
 - A sparse tensor is an N dimensional extension of a sparse matrix
 - MinkowskiEngine is a library that implements all standard neural network layers for sparse tensors
- ▶ Implement a U-Net architecture using sparse tensor layers

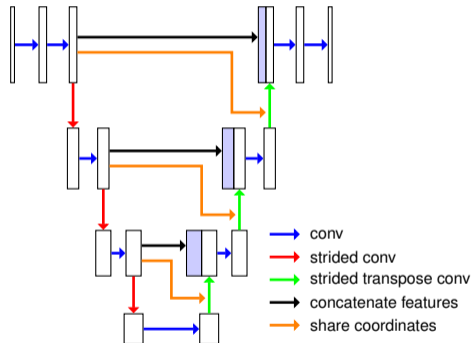

- ▶ Create training data by removing voxels using a randomly shifted mask of ND-LAr's drift module gaps
- ▶ Architecture requires all relevant coordinates to be defined in input
 - Use active pixels neighbouring the gaps to make reflections into gaps
 - Smear the reflected pixels to produce a mask of expected infill coordinates

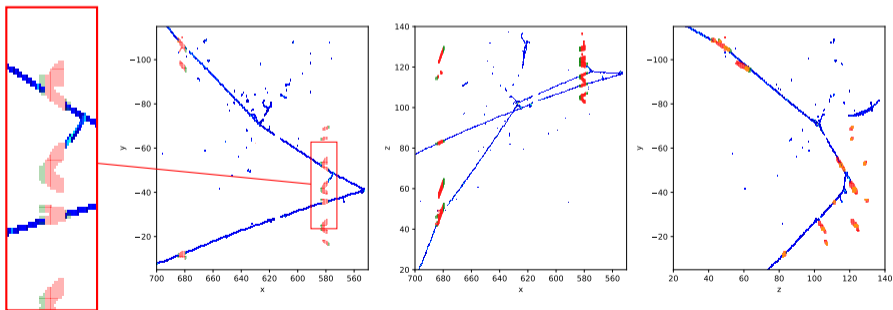

Infill Results — Early!

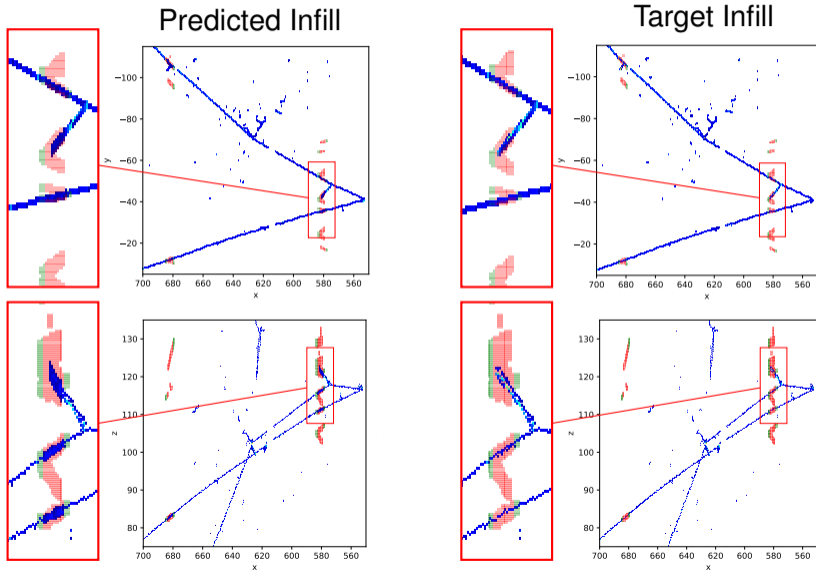

- ▶ PRISM allows oscillation physics to be studied with very little model-dependence if detector extrapolation is handled well
- ▶ Developed image-to-image translation approach to extrapolation
 - Generated paired ND-FD dataset
 - Model predictions show good agreement with truth for FD reconstruction
 - Demonstrated network removes a significant fraction of cross-section uncertainty compared to MC smearing
- ▶ Developed infill network to fill gaps in ND before translation
 - Using U-Net for sparse tensors
 - Initial results promising — more model tuning and exploration to do

Thank you!