

XENONnT from the point of view of a pulse

The black box which give you data
+ lots, lots, lots of cables

Peter Gaemers
Nikhef (Amsterdam)

85% of the matter in the universe is “Dark Matter”

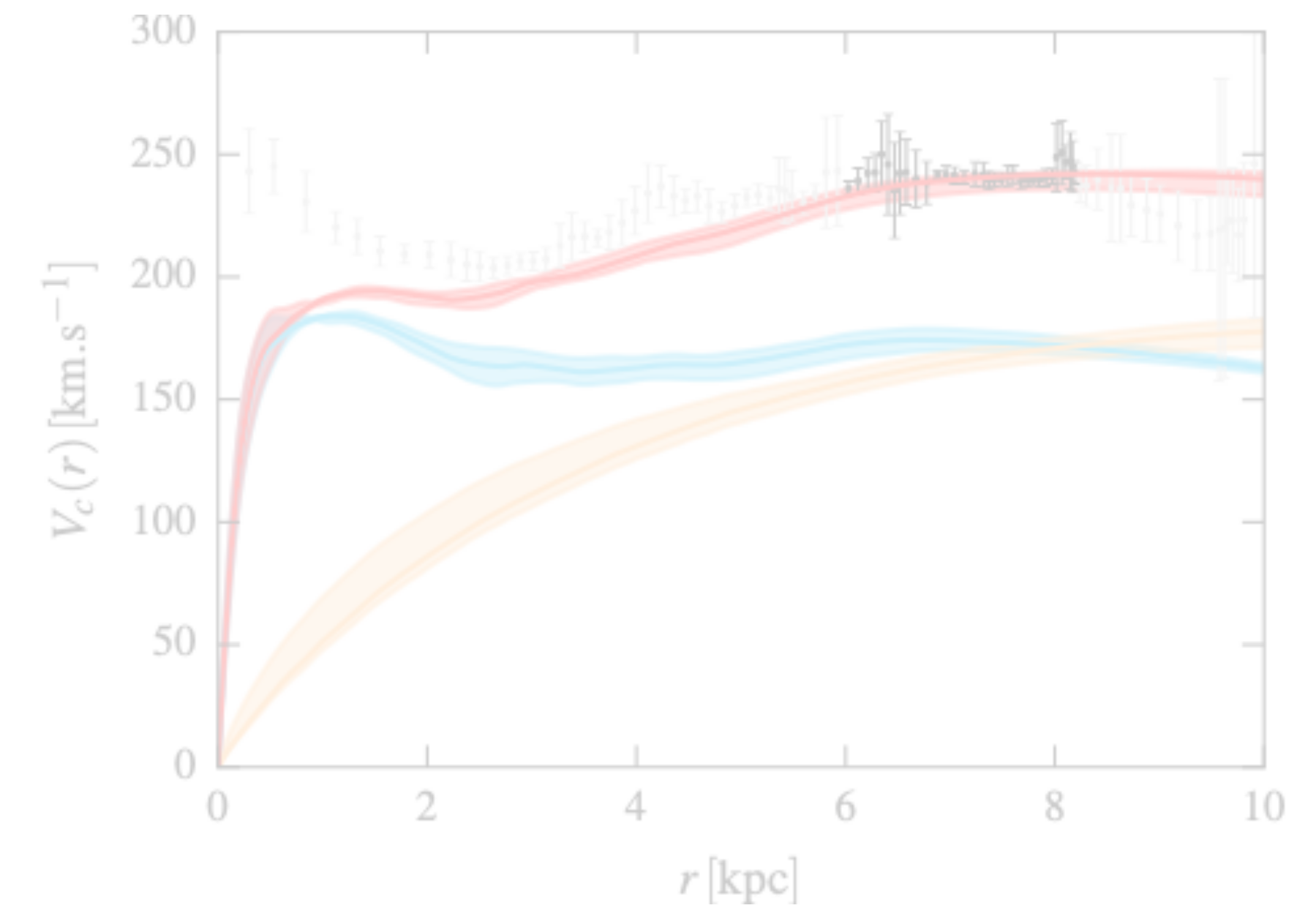
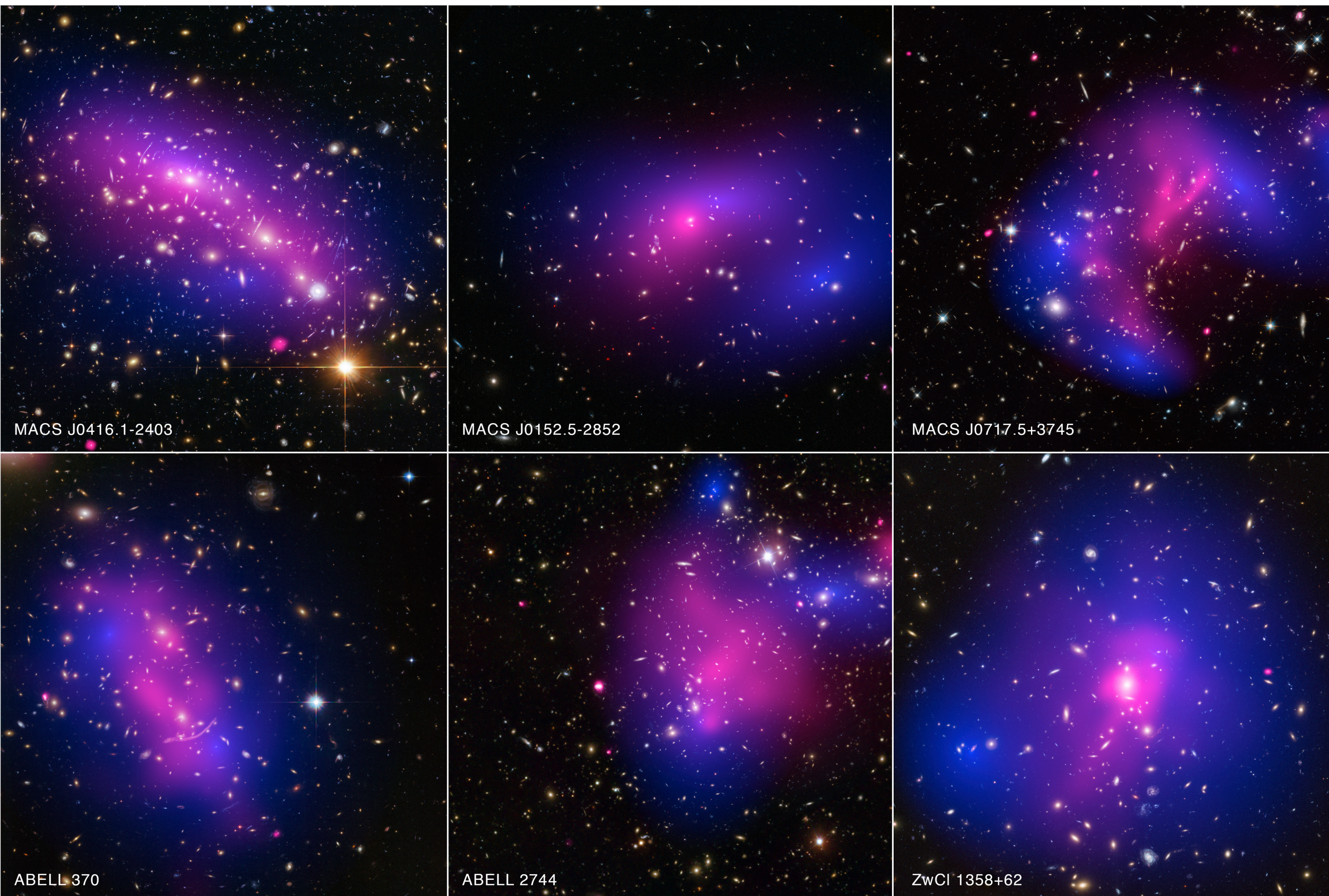

85% of the matter in the universe is “Dark Matter”

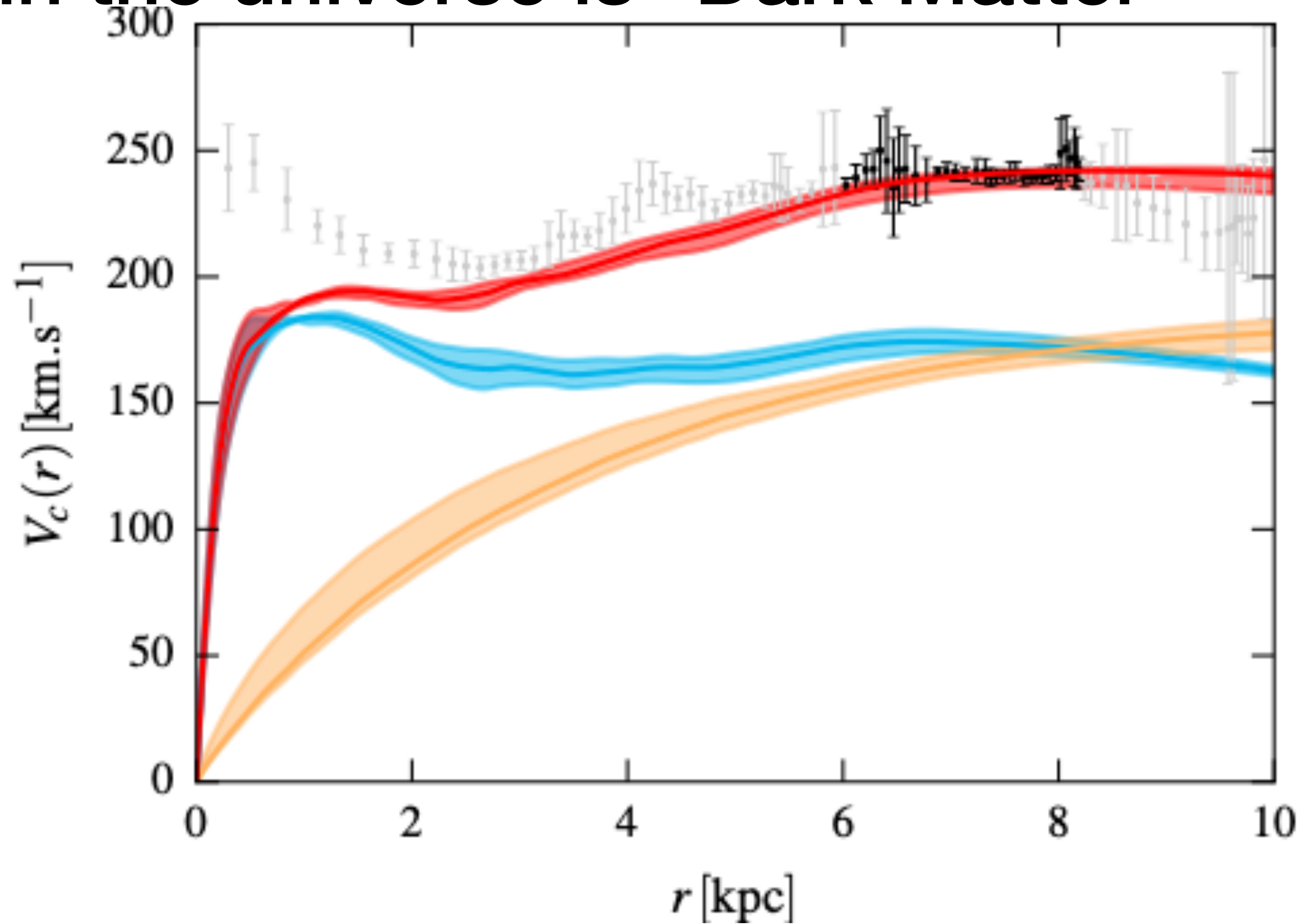

Matthieu Portail, Ortwin Gerhard, Christopher Wegg, and Melissa Ness. Dynamical modelling of the galactic bulge and bar: the milky way's pattern speed, stellar and dark matter mass distribution.

Monthly

Notices of the Royal Astronomical Society

, 465(2):1621–1644, Nov 2016

Mass scale of dark matter

(not to scale)

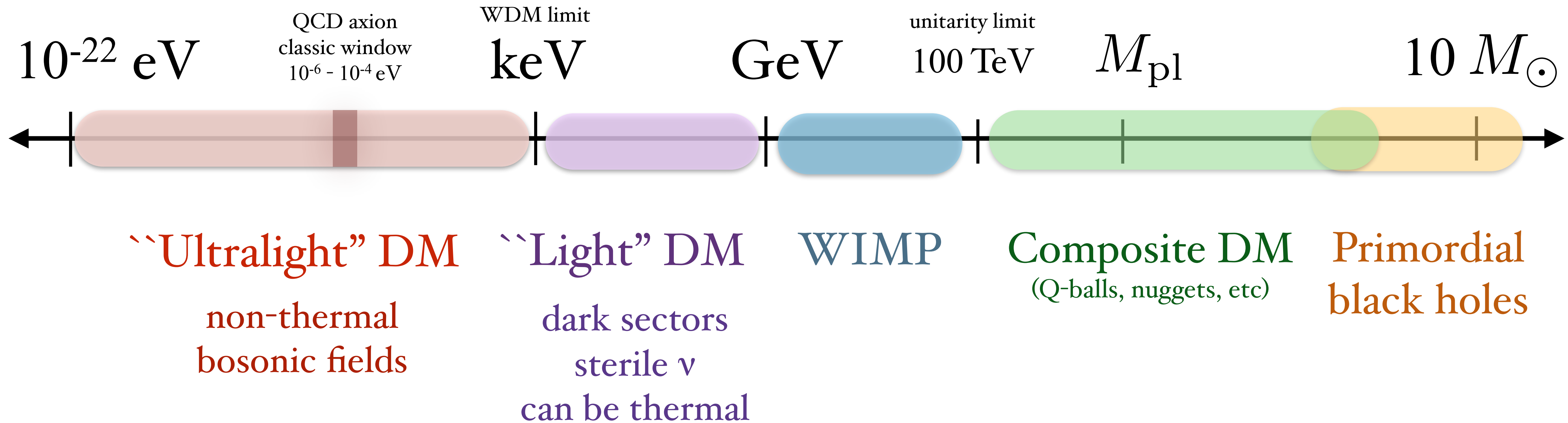

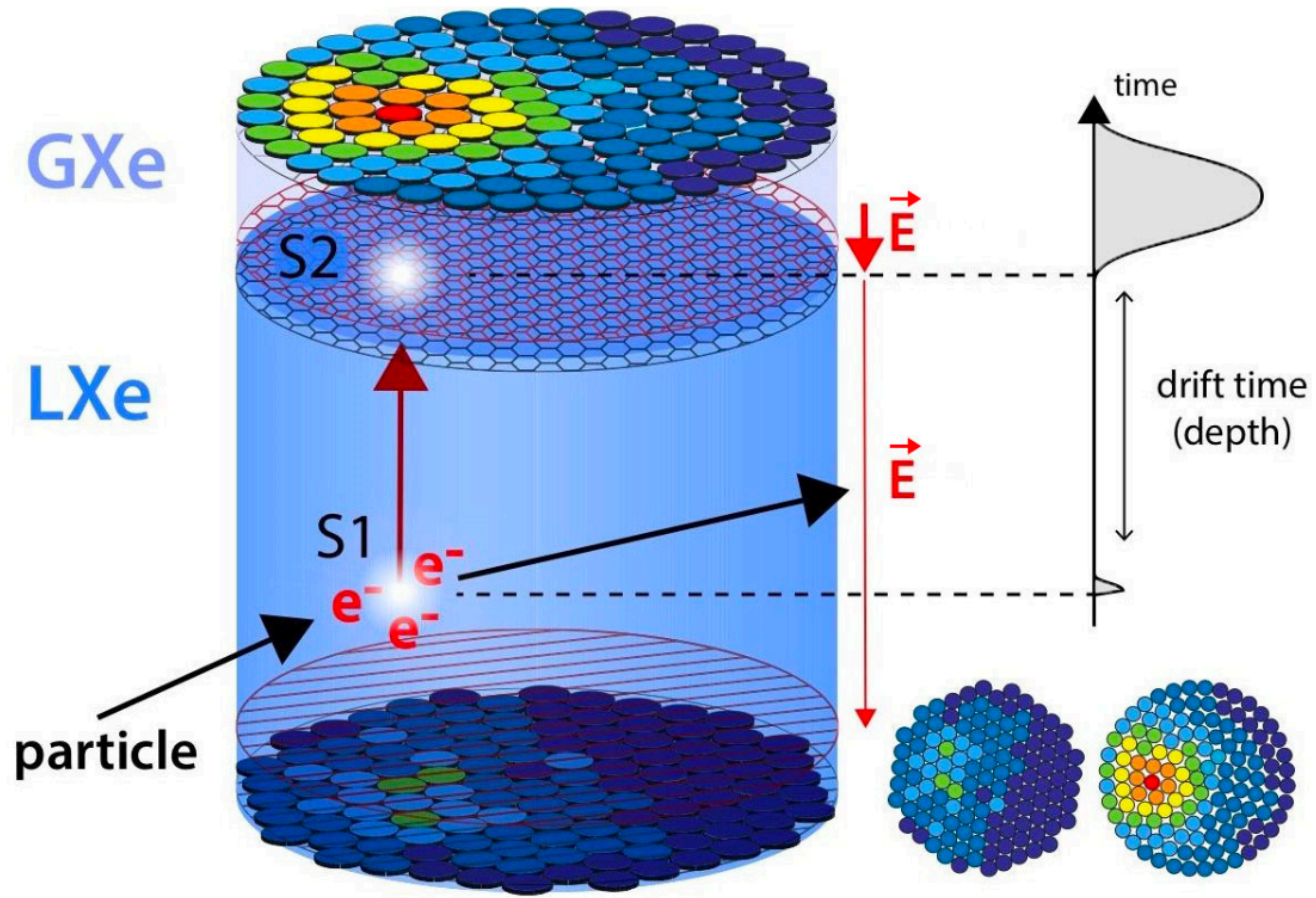



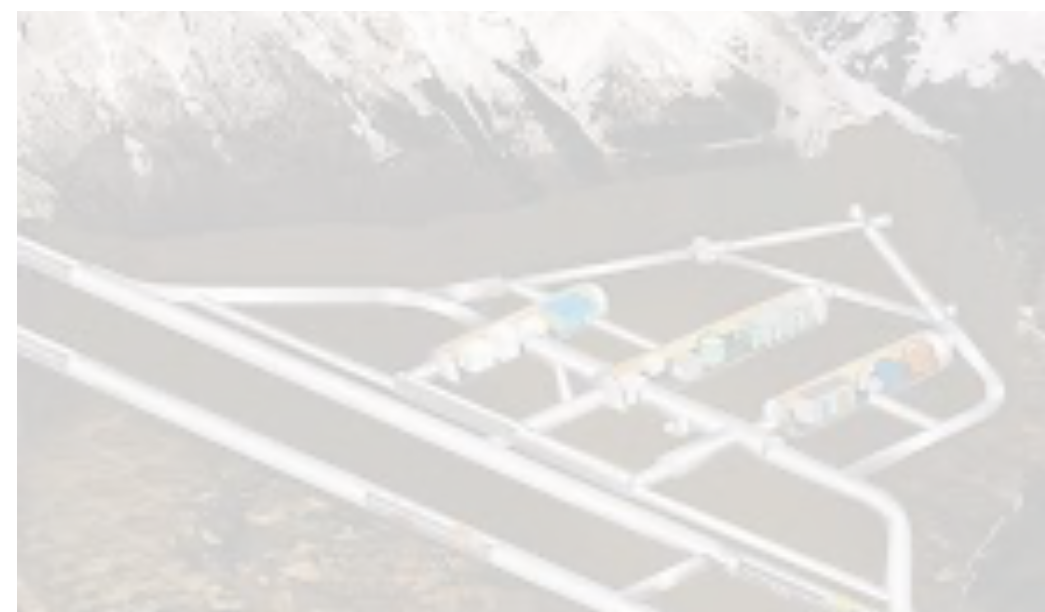



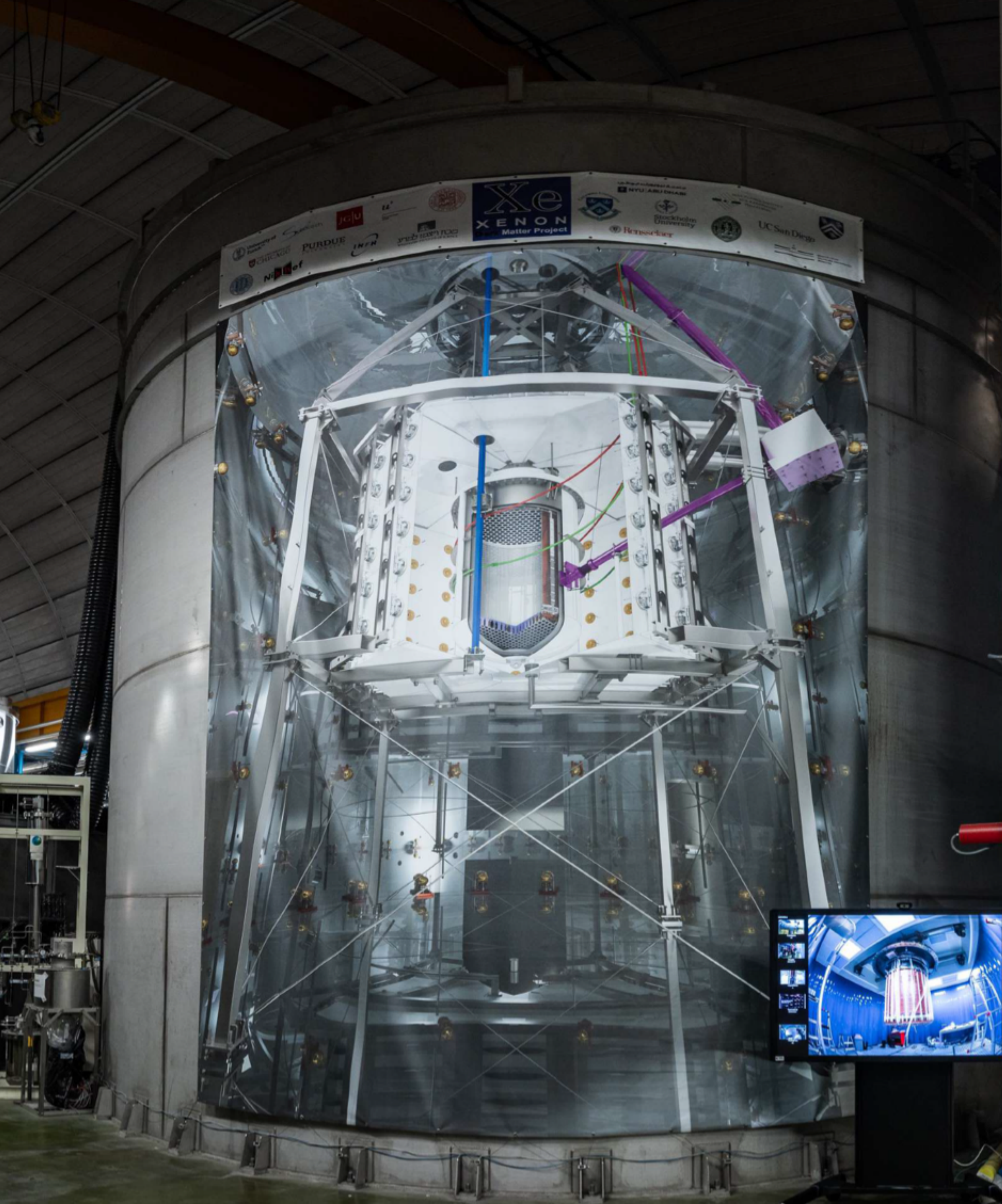

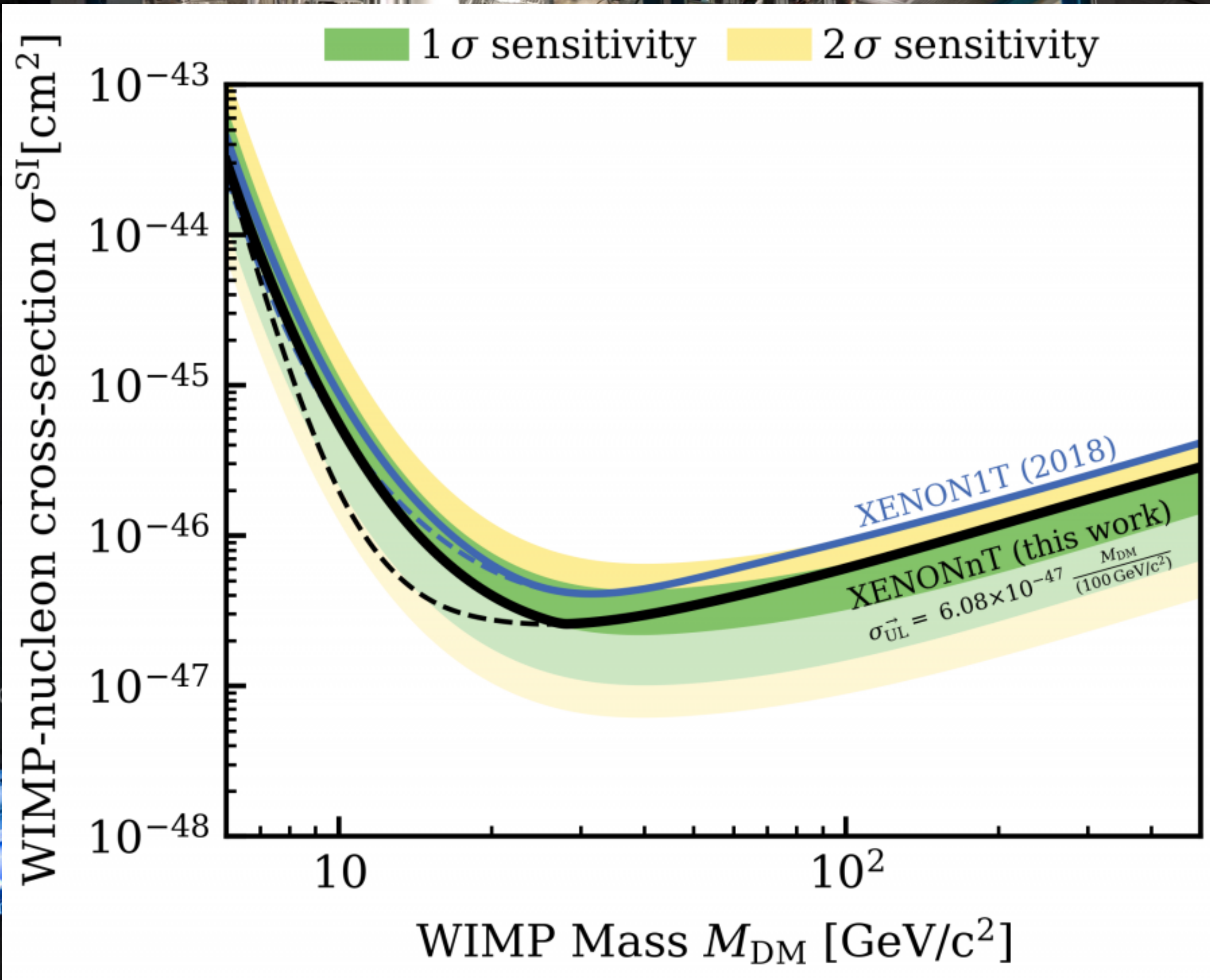
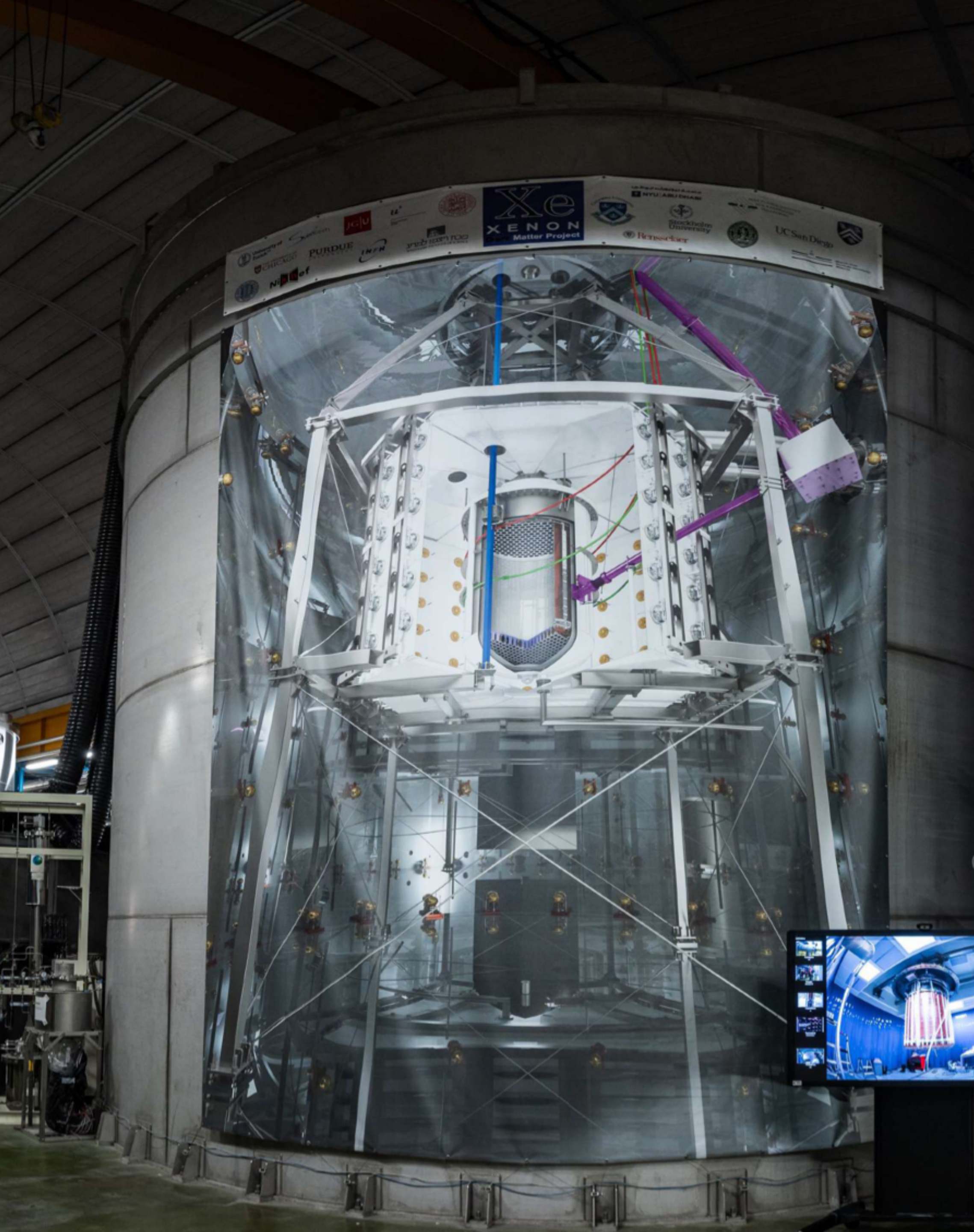

How is this line influenced by the system we use to take data?

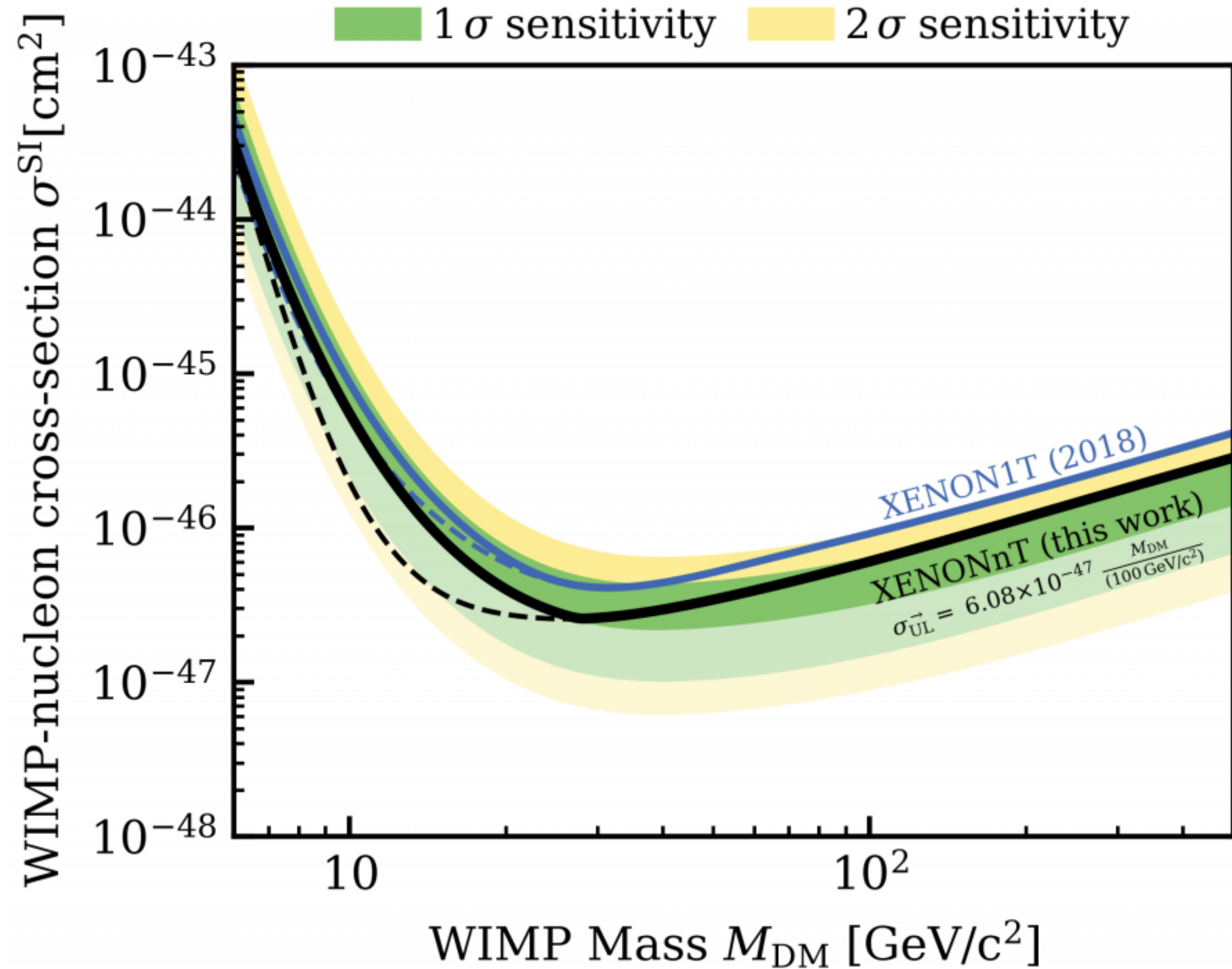

XENONnT DAQ Wishlist

Must haves

- Acquire data from both low (<10 keV) and high (>2 MeV) energy signals

- Low dead time
- Handle high data
- Low threshold

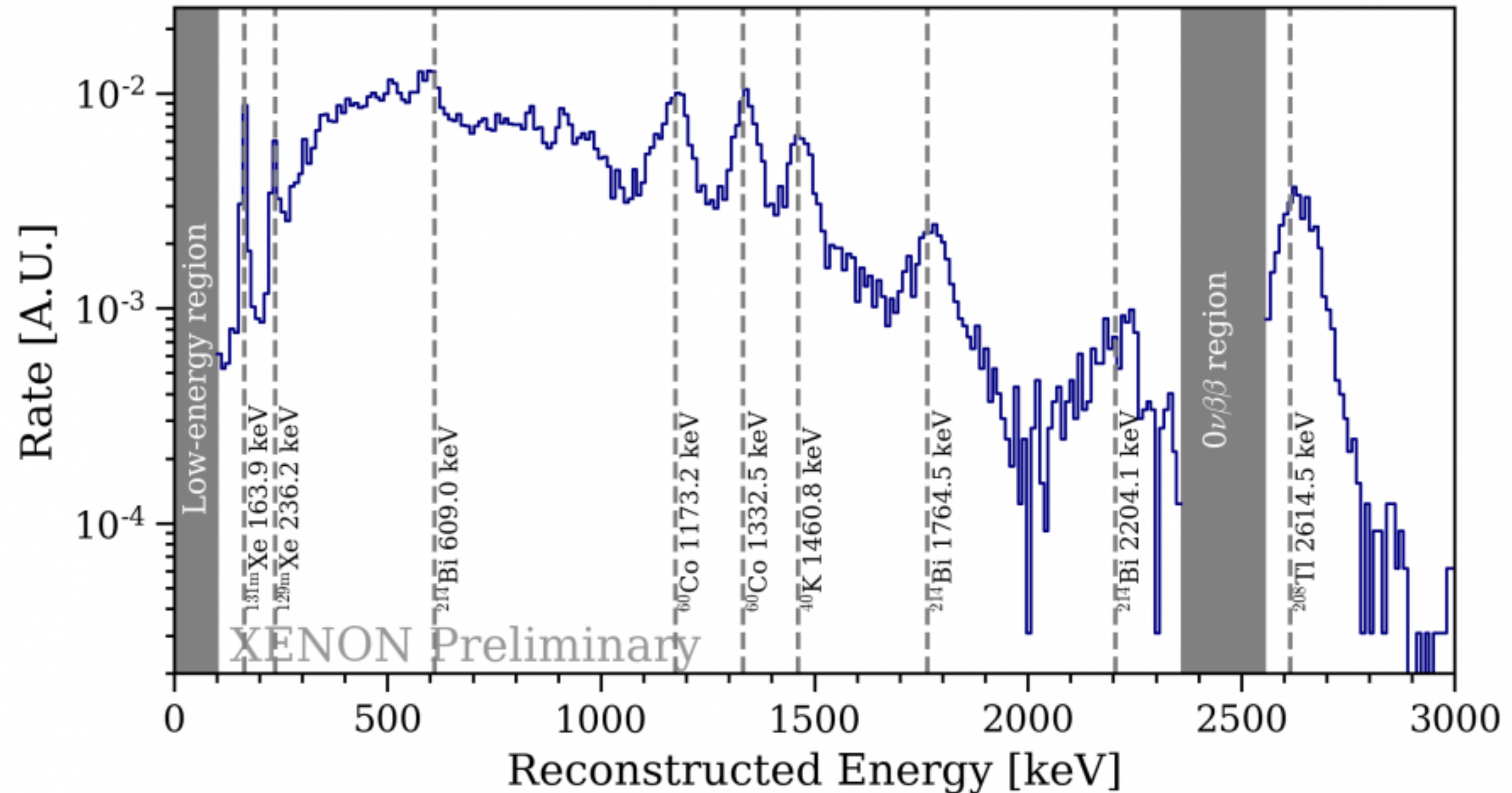

XENONnT DAQ Wishlist

Must haves

- Acquire data from both low (<10 keV) and high (>2 MeV) energy signals
- Low dead time
- Handle high data rates (calibration)
- Low threshold

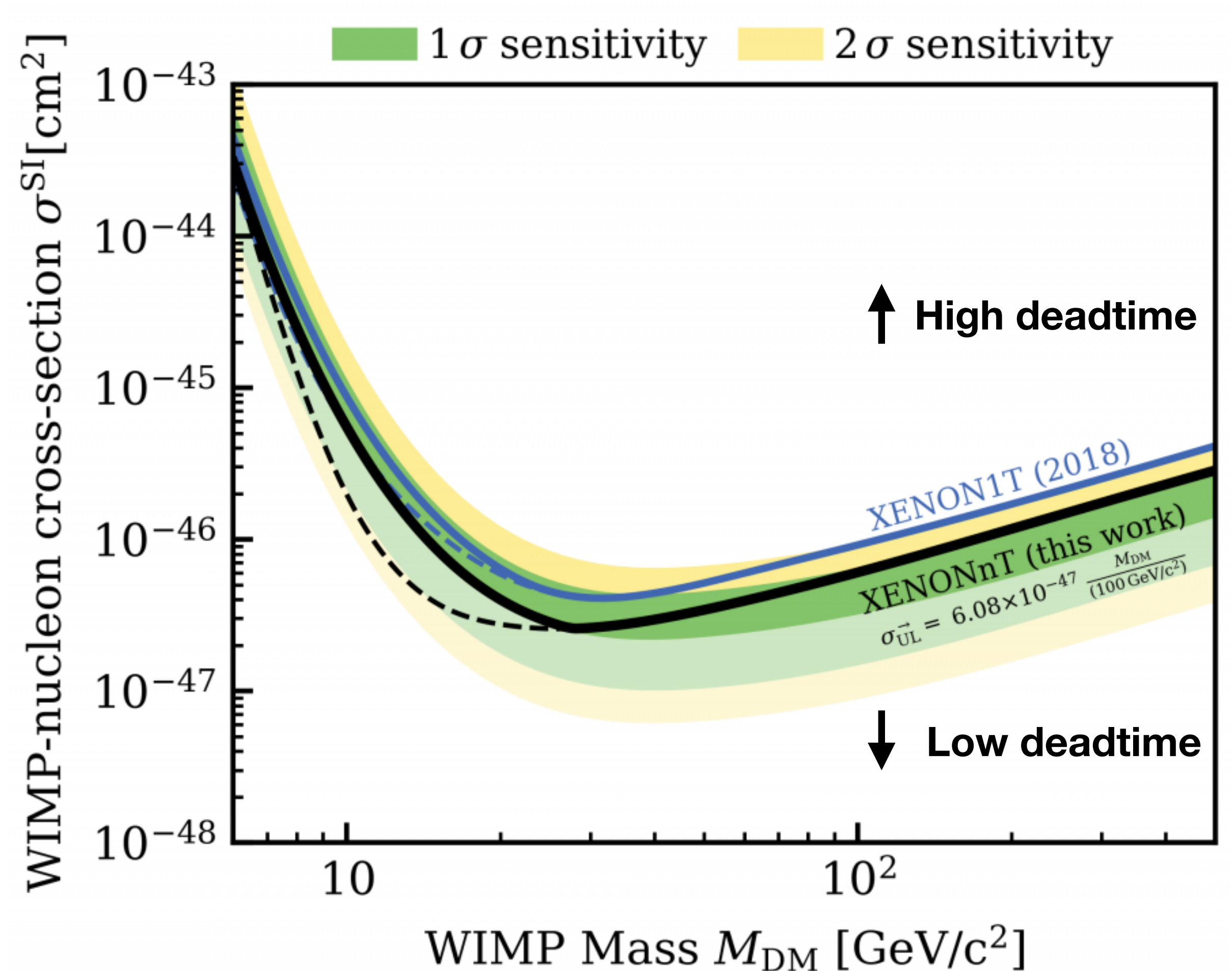

XENONnT DAQ Wishlist

Must haves

- Acquire data from both low (<10 keV) and high (>2 MeV) energy signals
- Low dead time
- Handle high data rates (calibration)

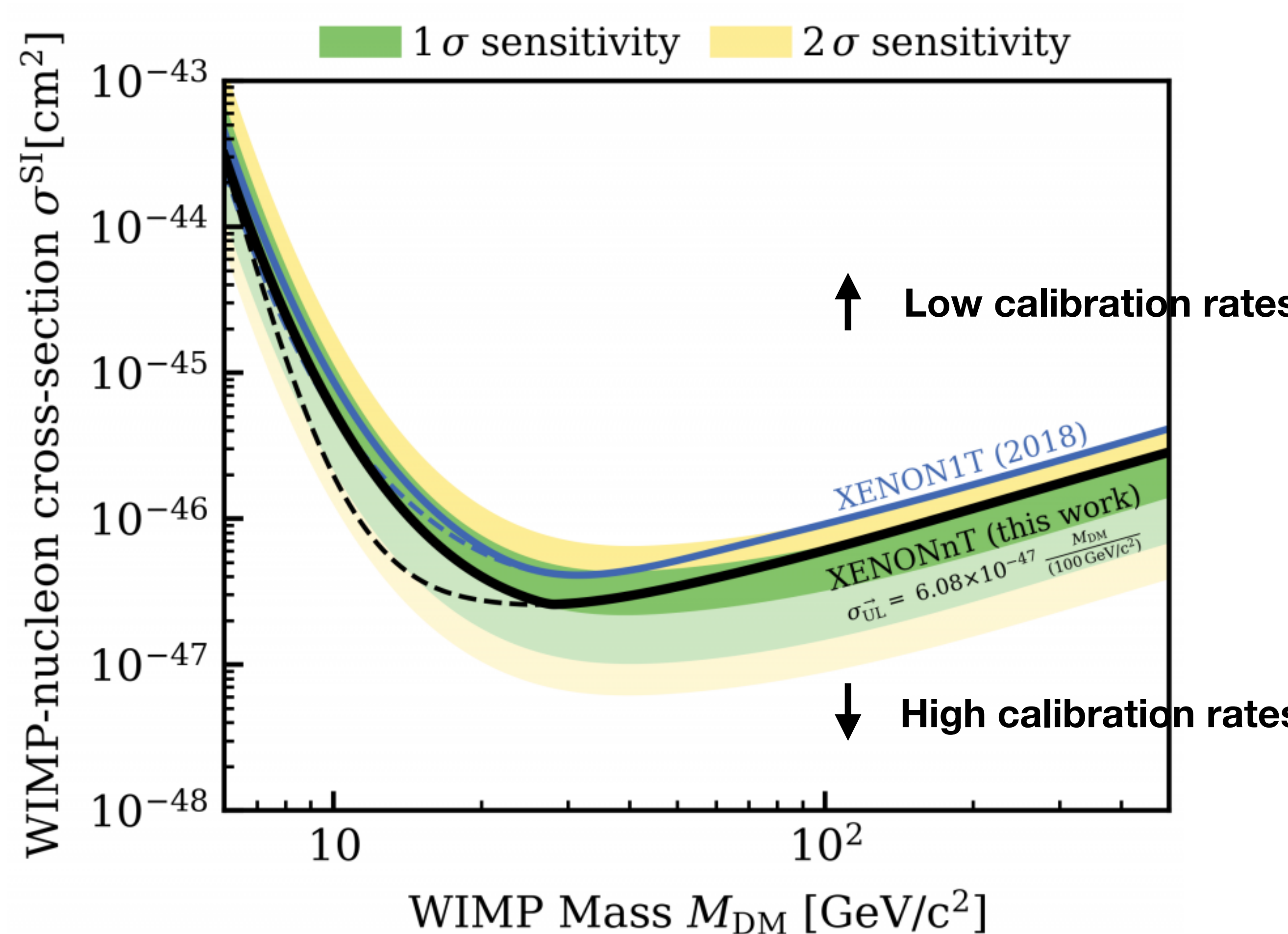

- Low threshold

XENONnT DAQ Wishlist

Must haves

- Acquire data from both low (<10 keV) and high (>2 MeV) energy signals
- Low dead time
- Handle high data rates (calibration)
- Low trigger threshold

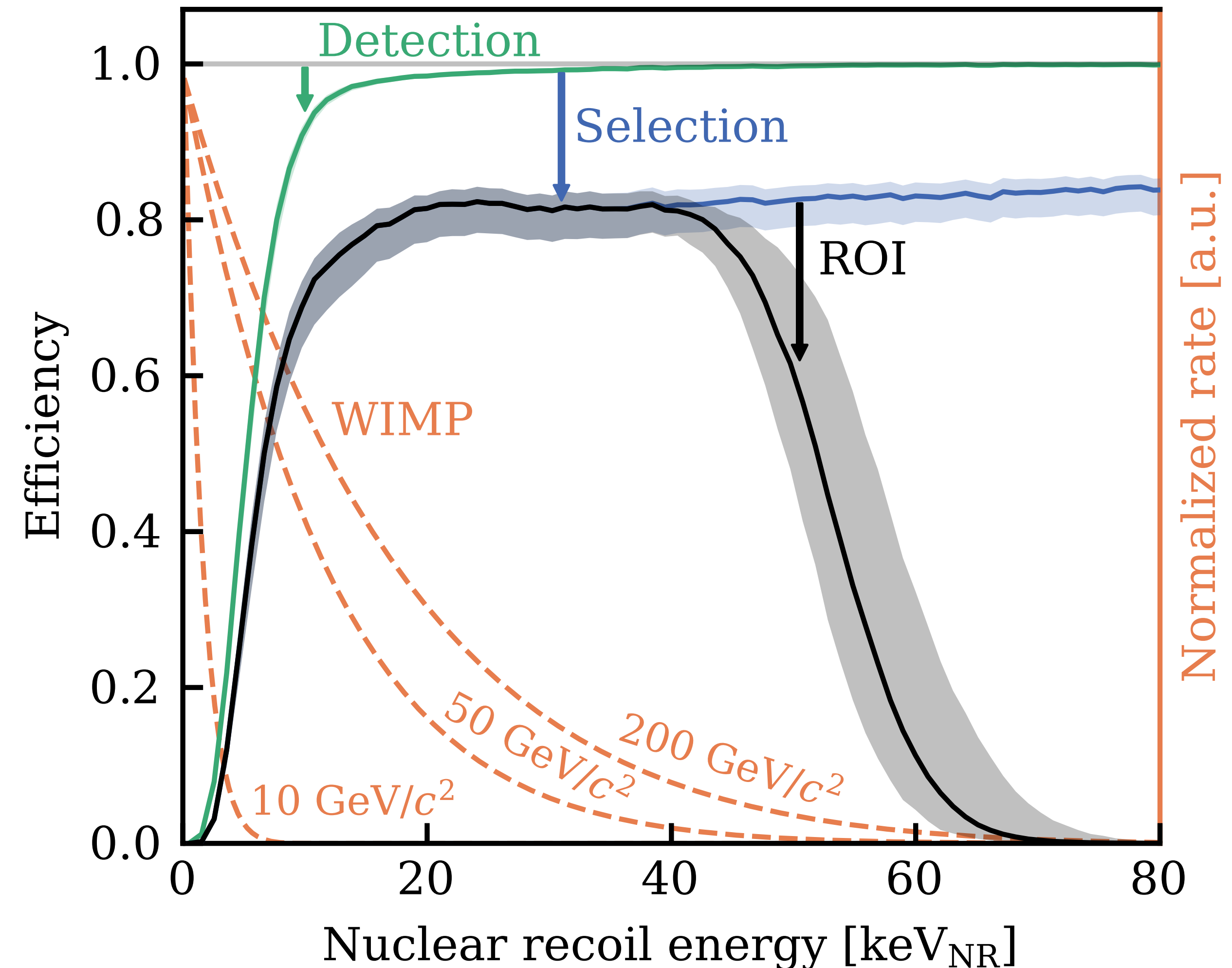

XENONnT DAQ Wishlist

Like haves

- Real time processing
- Data available as fast as possible
- Live monitoring
- No/low expert intervention required

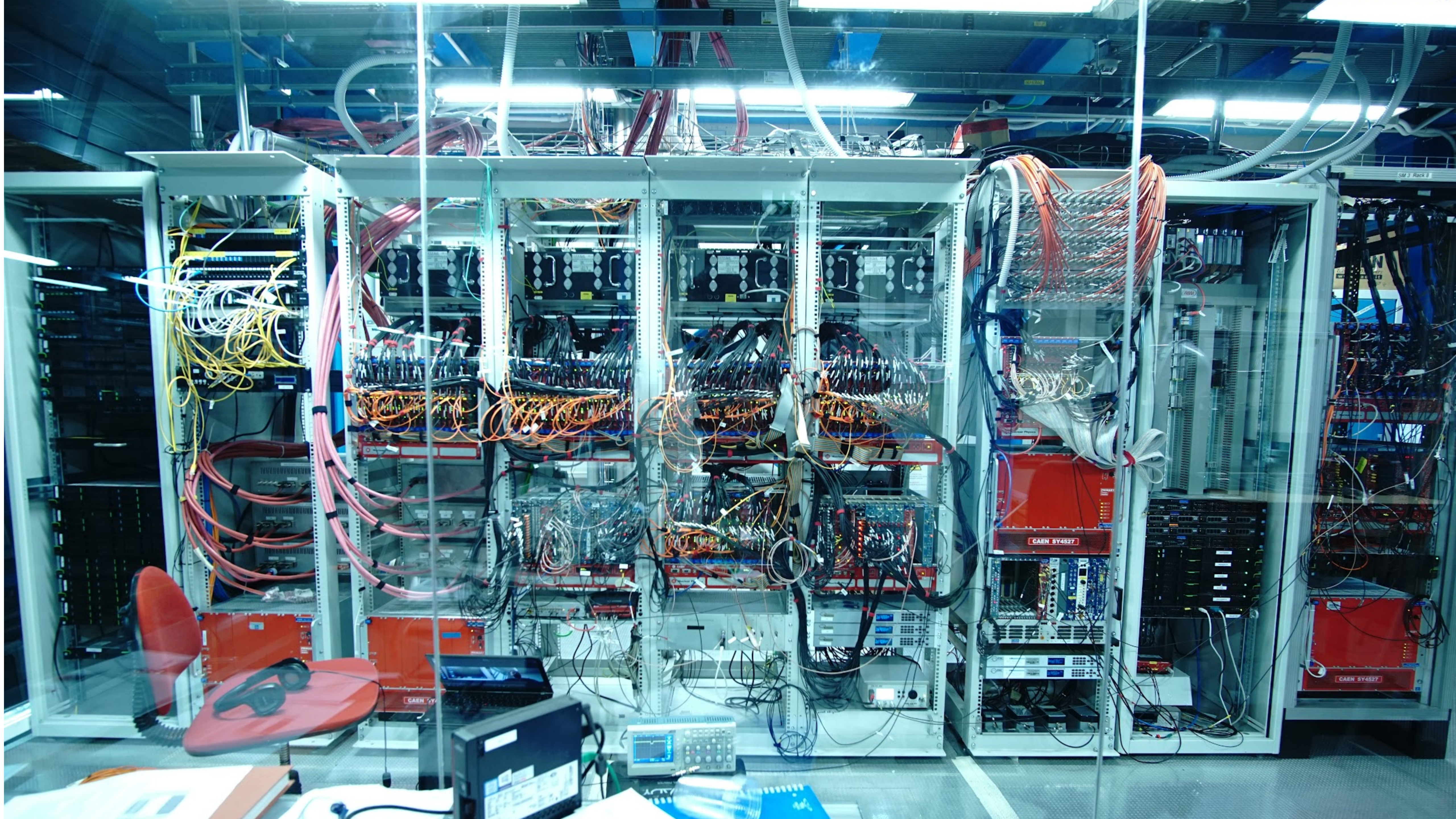

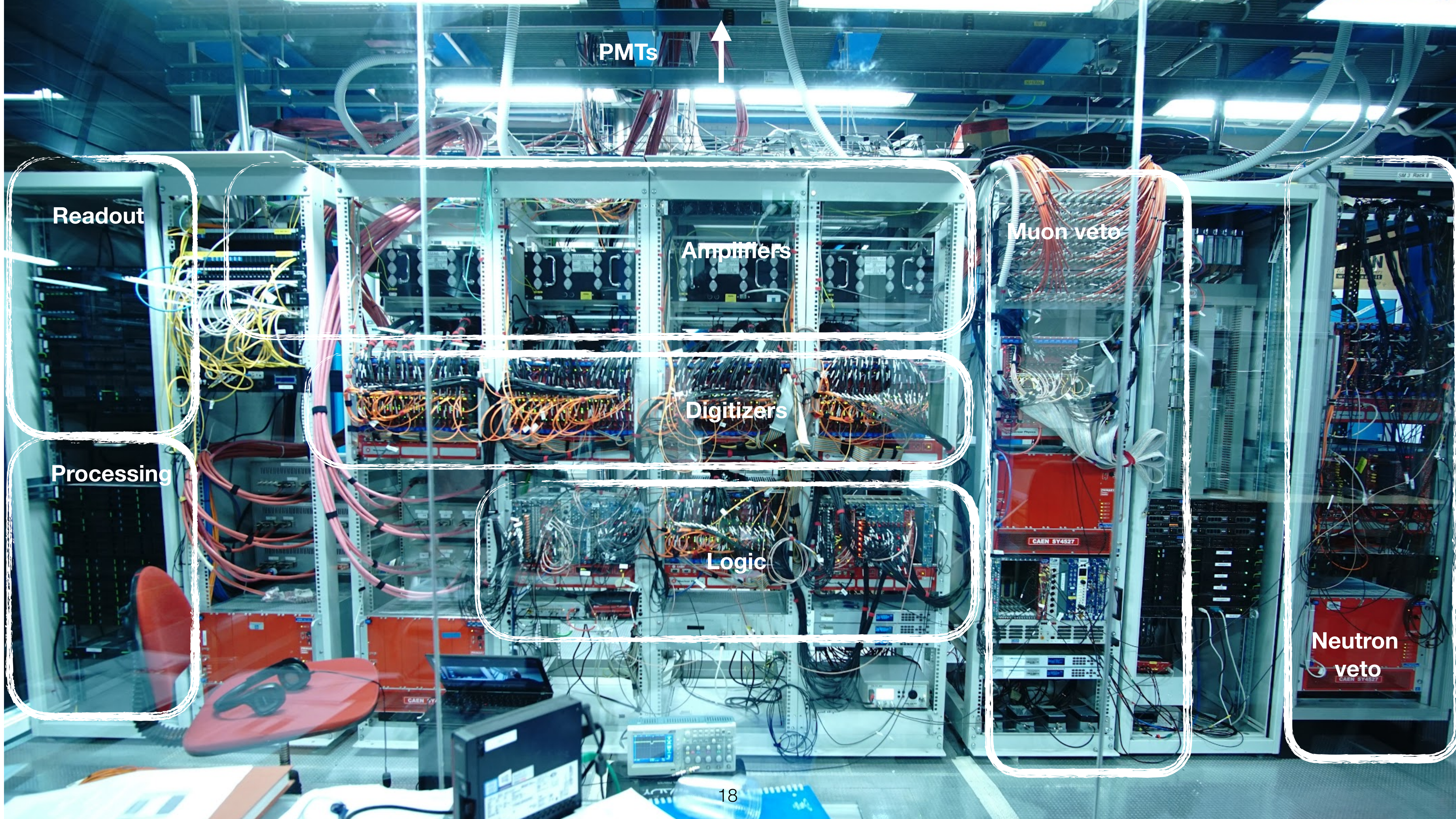

PMTs



Readout

Amplifiers

Muon veto

Digitizers

Processing

Logic

Neutron veto

 Analog signal
 Digital/logic signal

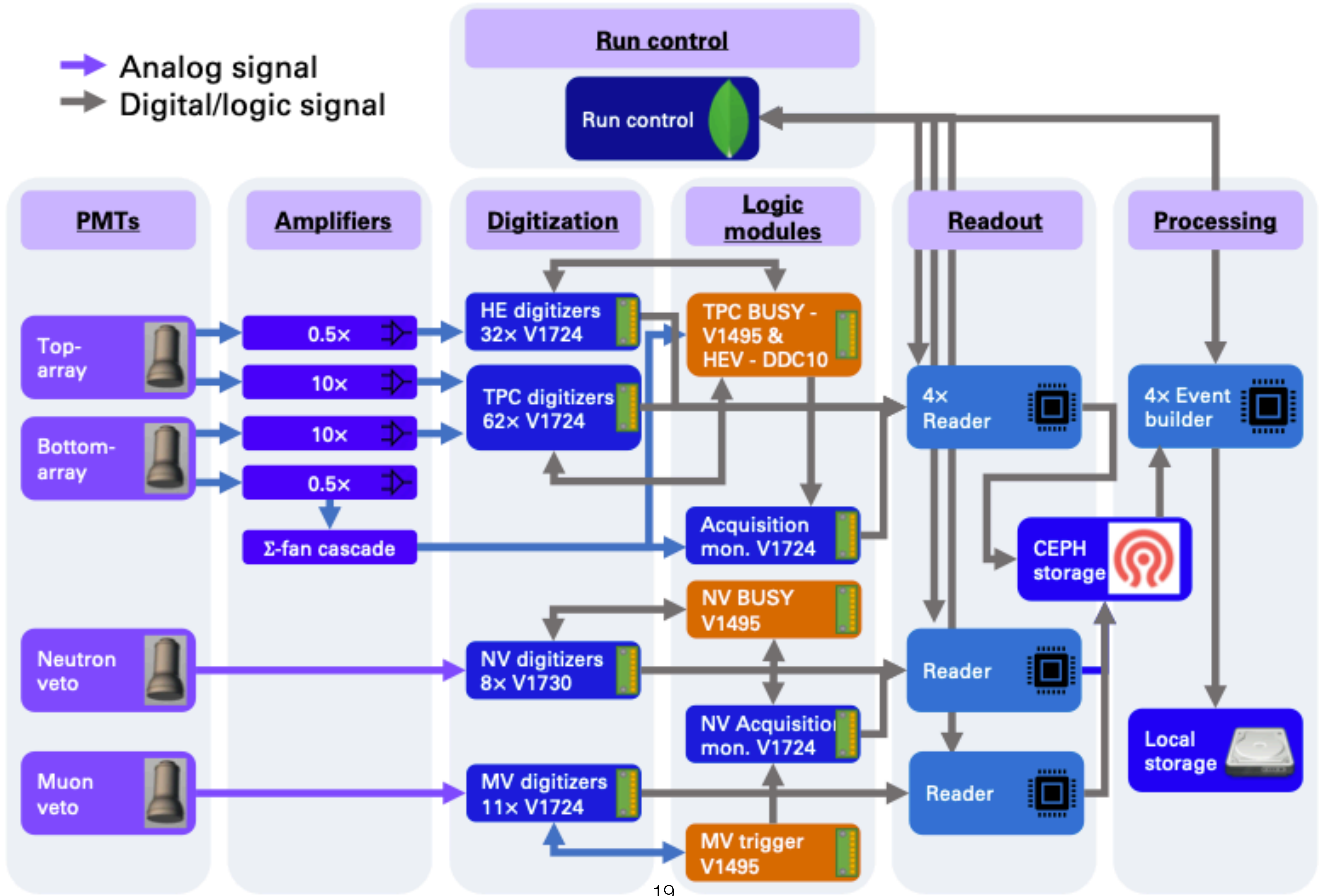

PMTs



PMTs



Amps

In

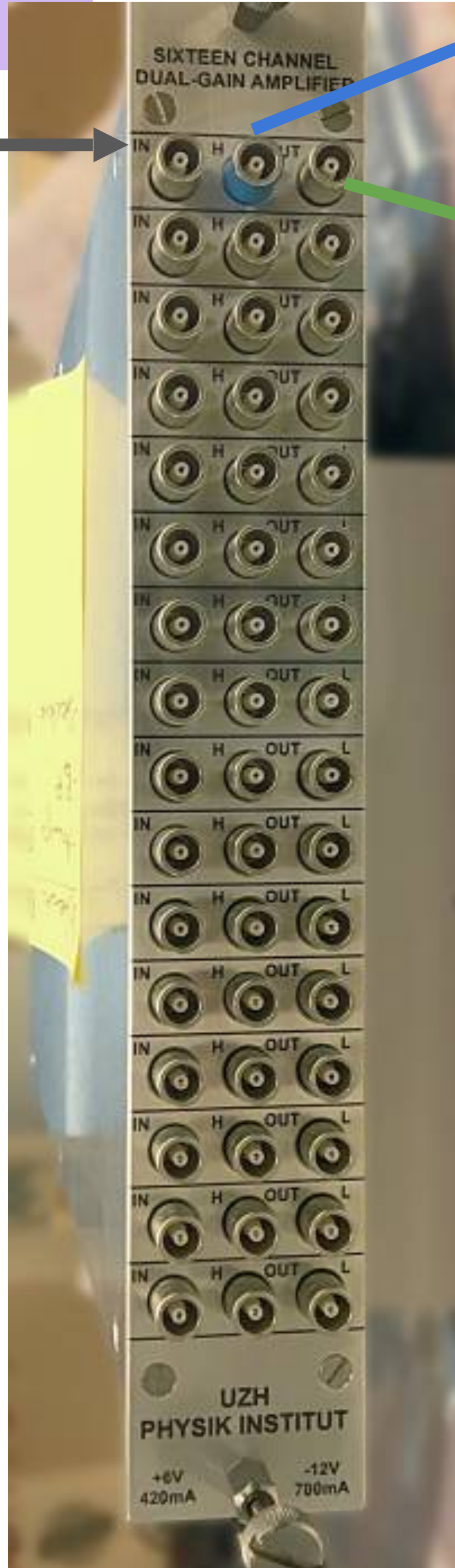

Output 0 x10, TPC low E

Output 1 x0.5, high E

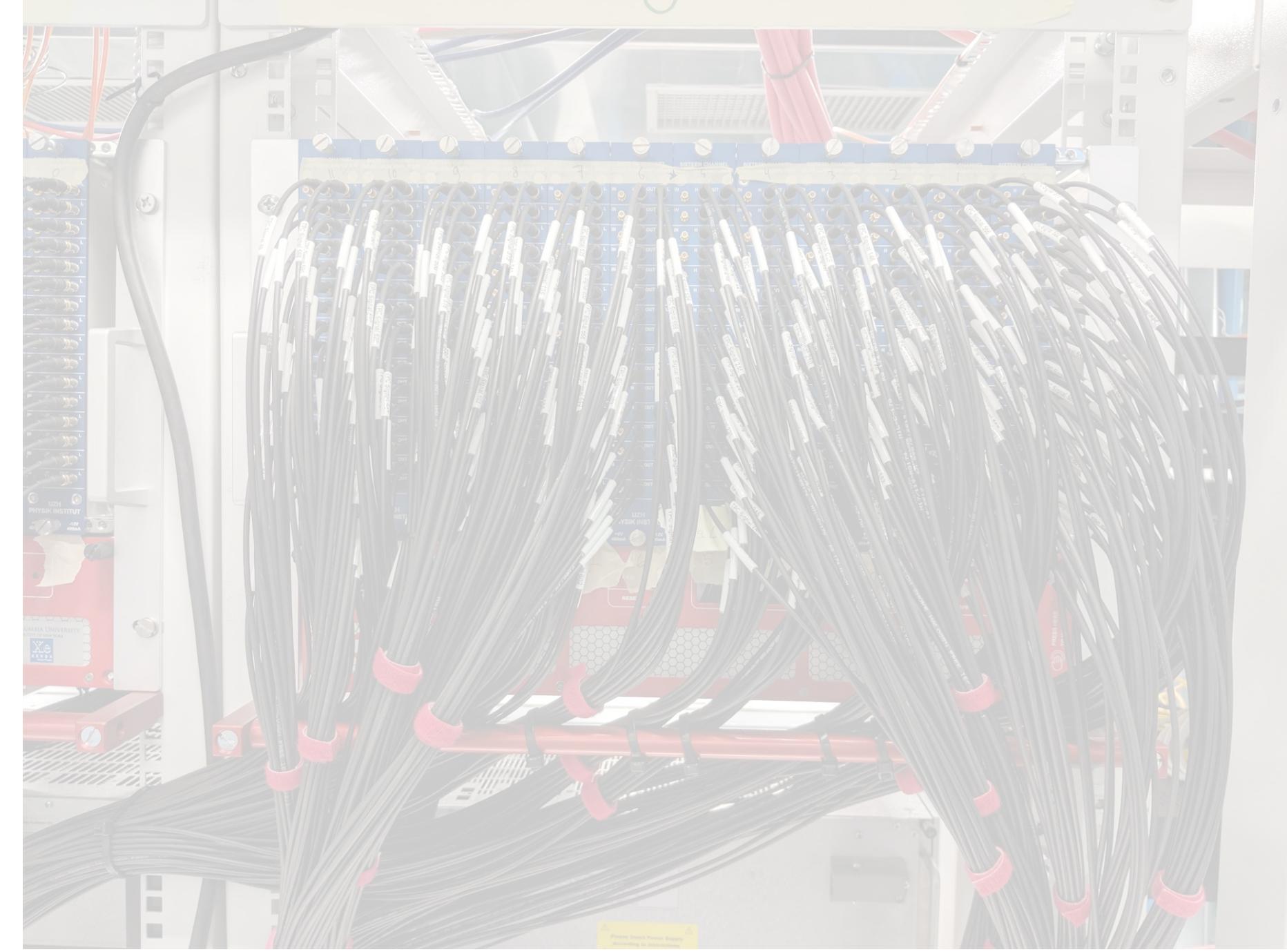

Amps

In

Out

Out

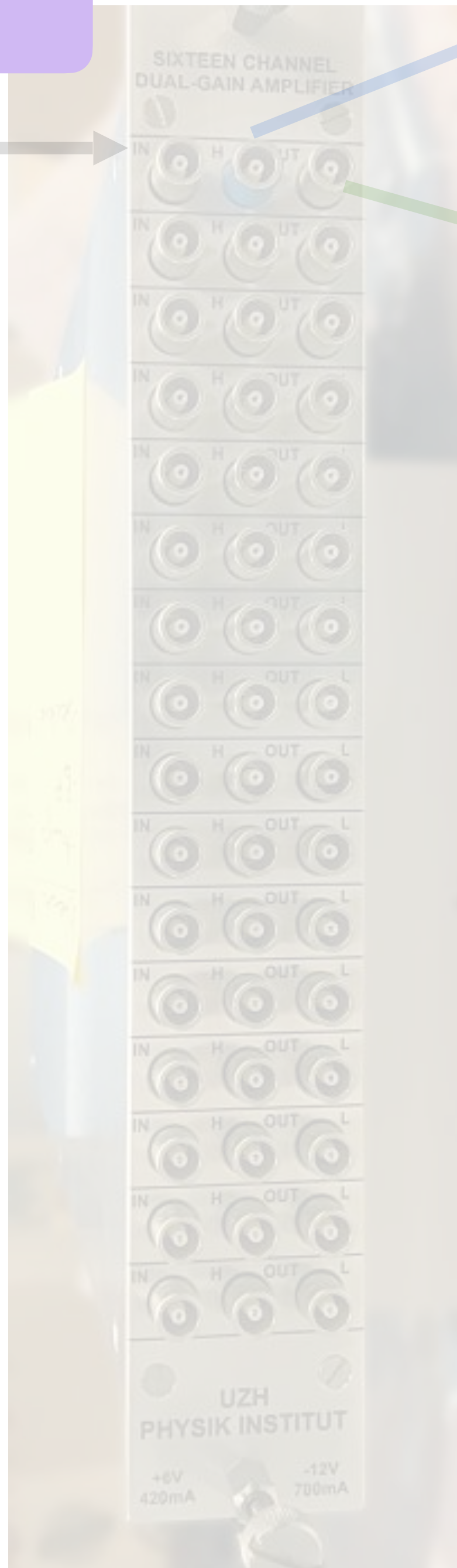

Amps

Output 0 x10, TPC low E

Output 1 x10

In

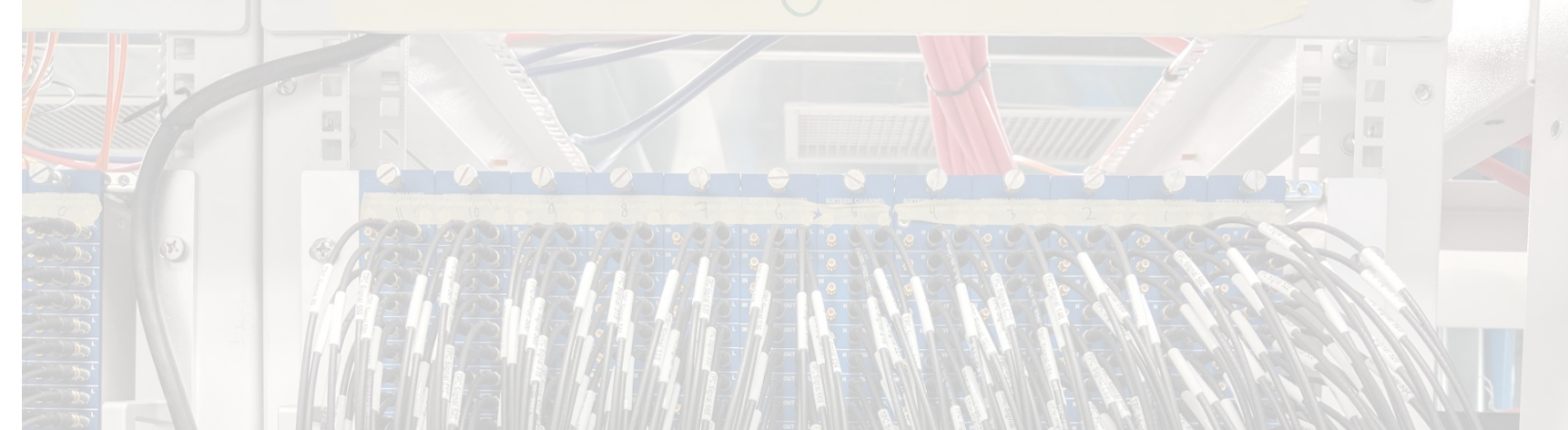
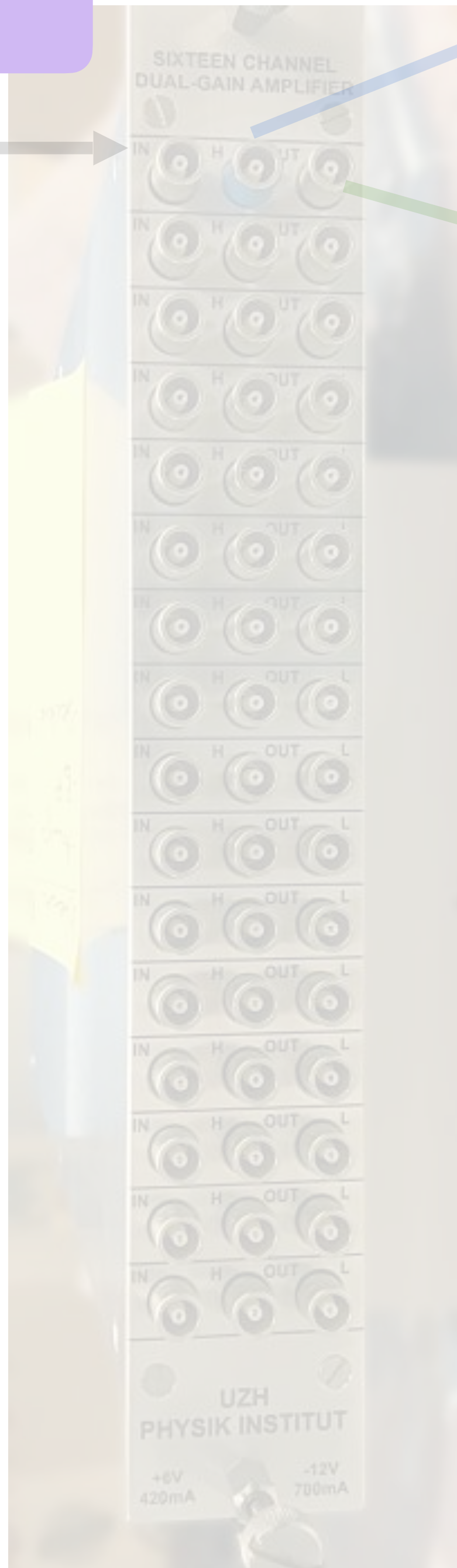

Digitizers



31	30	29	28	27	26	25	24	23	22	21	20	19	18	17	16	15	14	13	12	11	10	9	8	7	6	5	4	3	2	1	0
----	----	----	----	----	----	----	----	----	----	----	----	----	----	----	----	----	----	----	----	----	----	---	---	---	---	---	---	---	---	---	---

1	0	1	0	EVENT SIZE												RESERVED													
BOARD ID				BF	RES	PATTERN/TRG OPTIONS												CHANNEL MASK [7:0]											
RESERVED				BOARD EVENT COUNTER																									
BOARD EVENT TIME TAG																													

RESERVED				CHANNEL SIZE																					
RESERVED				TRIGGER TIME STAMP																					
0	0											0	0											S ₀	
0	0											S ₁	0	0											S ₂
0	0											S ₃	0	0											S ₂
...																									
0	0											S _{n-1}	0	0											S _{n-2}

HEADER

FIRST CH DATA

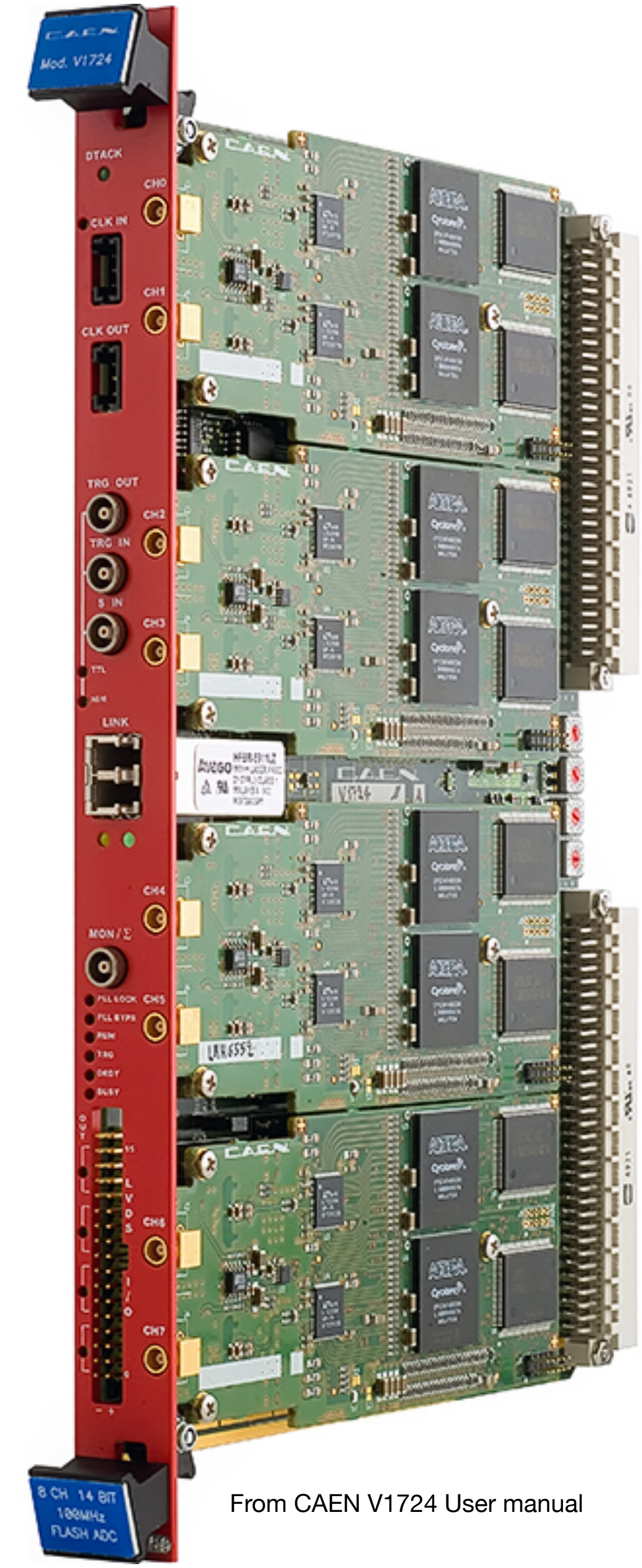

From CAEN V1724 User manual

Digitizers

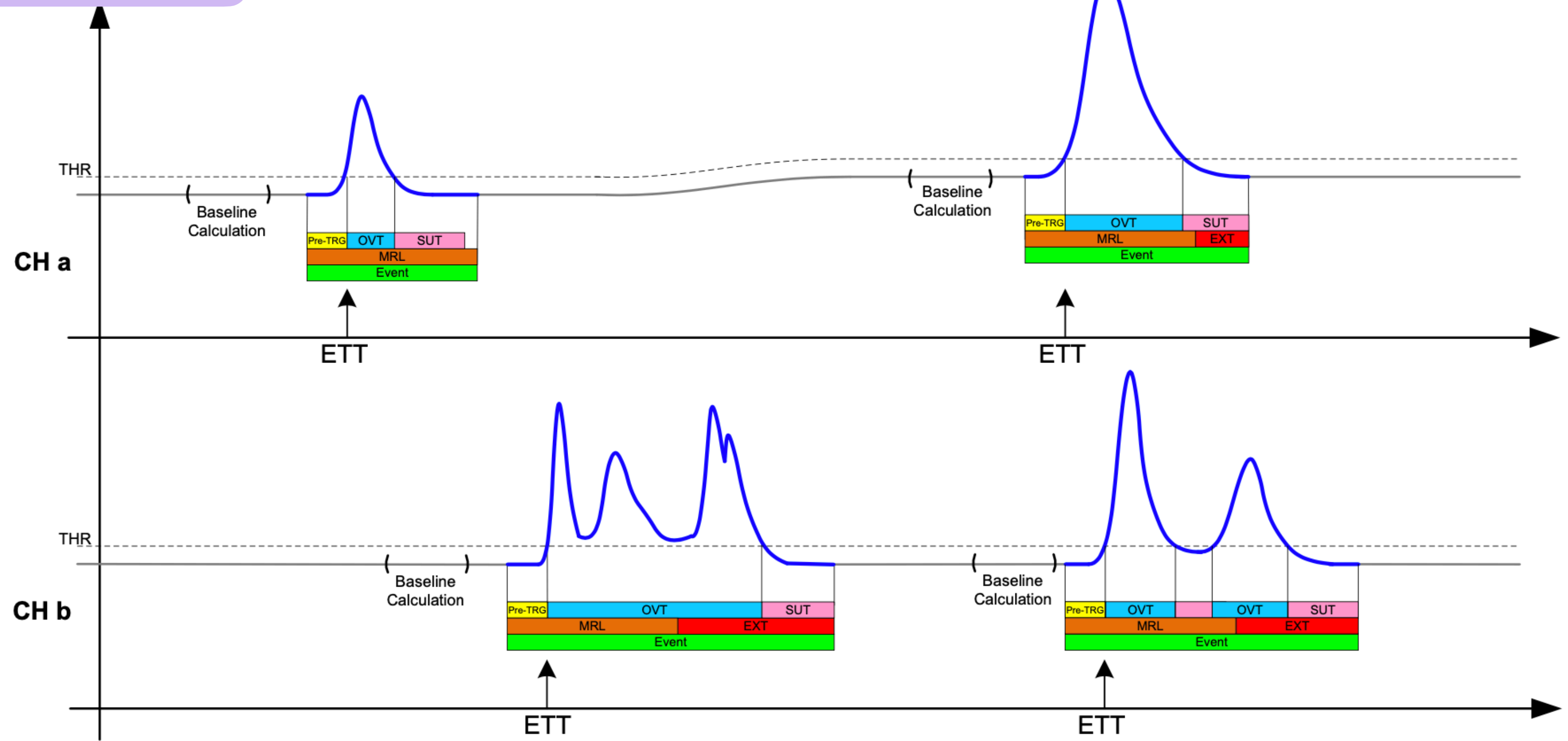

- Pre-TRG** *Pre Trigger*: number of samples before trigger
- OVT** *Over Threshold*: lasts as long as the signal is over threshold
- SUT** *Samples Under Threshold*: minimum number of samples that have to be under threshold before an event can be closed
- Event** *Event*: samples stored in the digitizer memories for each triggered pulse
- MRL** *Minimum Record Length*: defines the shortest event
- EXT** *Extended Length*: extra samples added to an event according to the signal Time Over Threshold
- ETT** Event Time Tag
- Acquired waveform
- Input Signal

From Caen User Manual UM5954 DPP-DAW Digital Pulse Processing for Dynamic Acquisition Window

RESERVED		CHANNEL SIZE	
0	0	TRIGGER TIME STAMP	
0	0	S ₁	S ₀
0	0	S ₃	S ₂
		...	
0	0	S _{n-1}	S _{n-2}

FIRST CH DATA

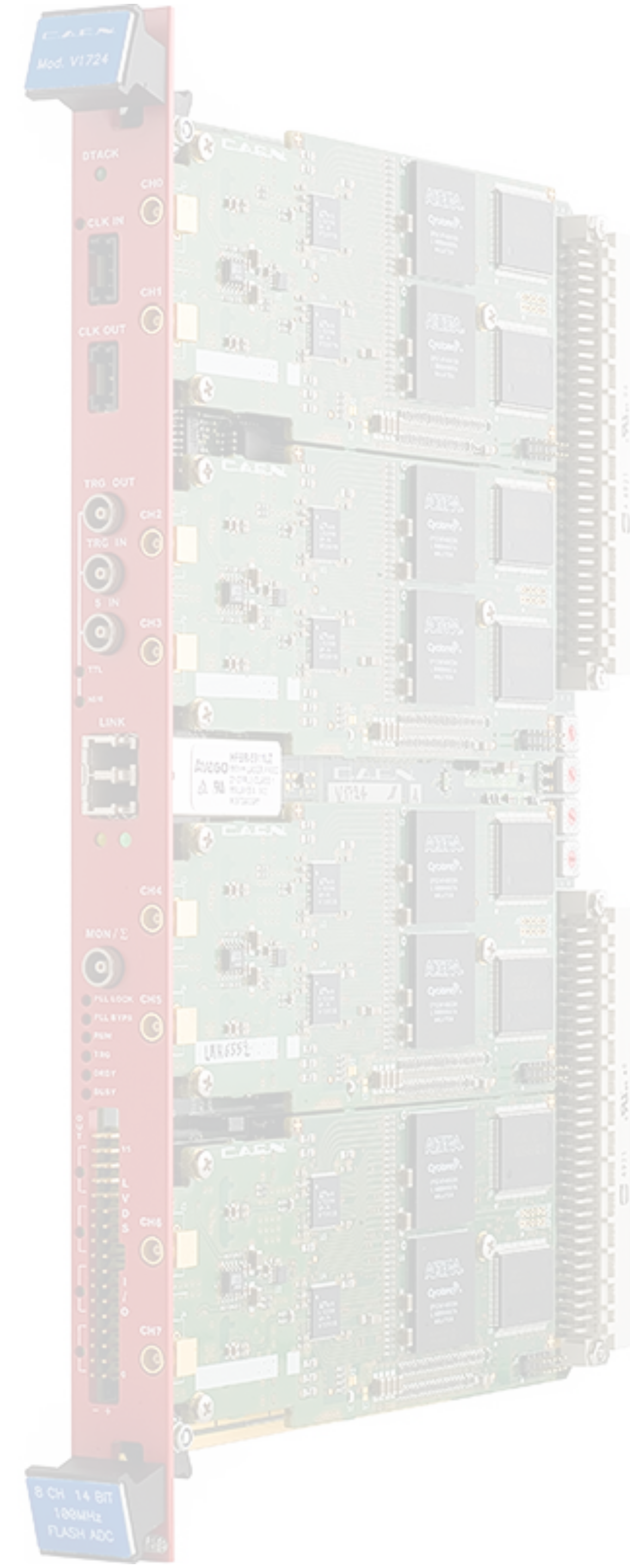

Digitizers

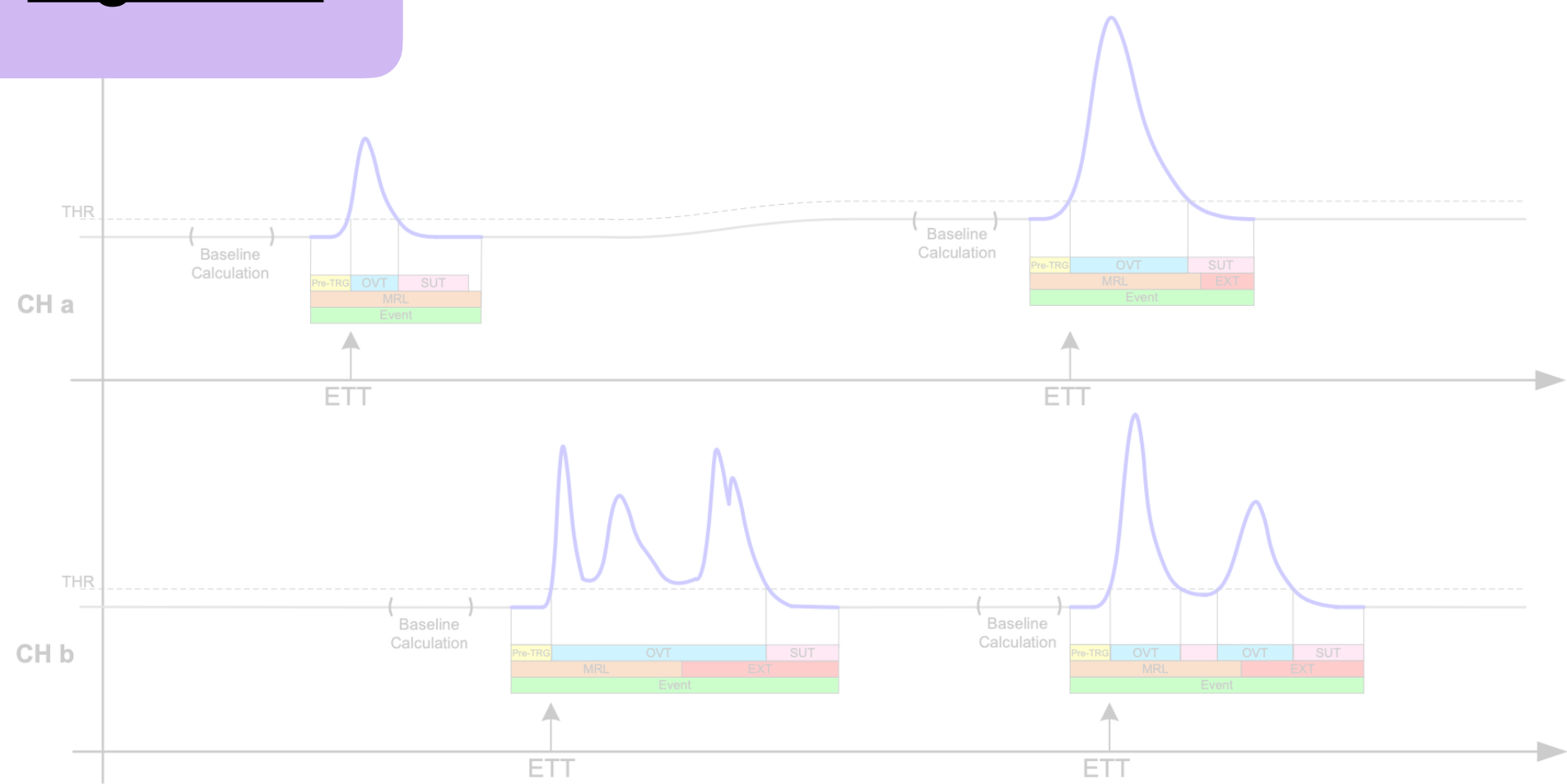

- Pre-TRG **Pre Trigger:** number of samples before trigger
- OVT **Over Threshold:** lasts as long as the signal is over threshold
- SUT **Samples Under Threshold:** minimum number of samples that have to be under threshold before an event can be closed
- Event **Event:** samples stored in the digitizer memories for each triggered pulse
- MRL **Minimum Record Length:** defines the shortest event
- EXT **Extended Length:** extra samples added to an event according to the signal Time Over Threshold
- ETT **Event Time Tag**

From Caen User Manual UM5954 DPP-DAW Digital Pulse Processing for Dynamic Acquisition Window

31	30	29	28	27	26	25	24	23	22	21	20	19	18	17	16	15	14	13	12	11	10	9	8	7	6	5	4	3	2	1	0
----	----	----	----	----	----	----	----	----	----	----	----	----	----	----	----	----	----	----	----	----	----	---	---	---	---	---	---	---	---	---	---

1	0	1	0	EVENT SIZE															
BOARD ID				BF	RES	PATTERN/TRG OPTIONS										CHANNEL MASK [7:0]			
RESERVED					BOARD EVENT COUNTER														
BOARD EVENT TIME TAG																			

HEADER

RESERVED				CHANNEL SIZE													
0	0	TRIGGER TIME STAMP															
0	0	S_1										0	0	S_0			
0	0	S_3										0	0	S_2			
...																	
0	0	S_{n-1}										0	0	$27 S_{n-2}$			

FIRST CH DATA

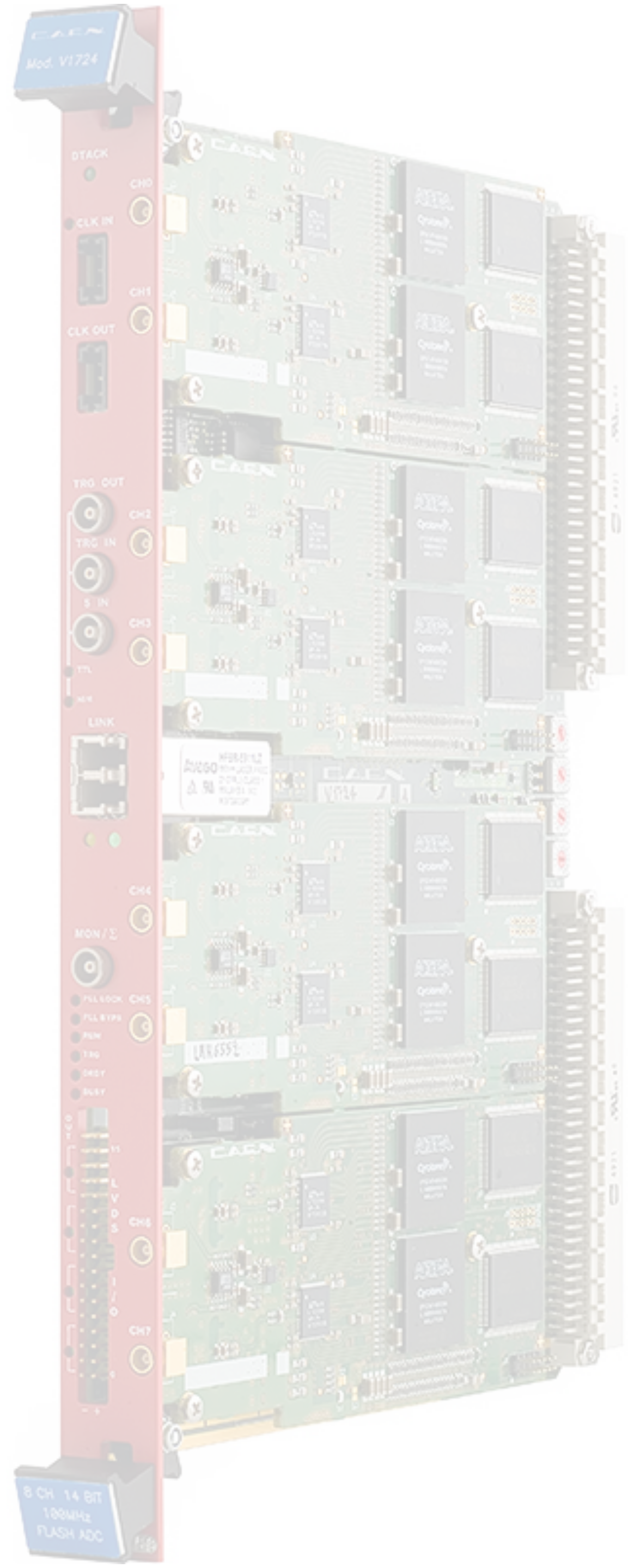

Digitizers

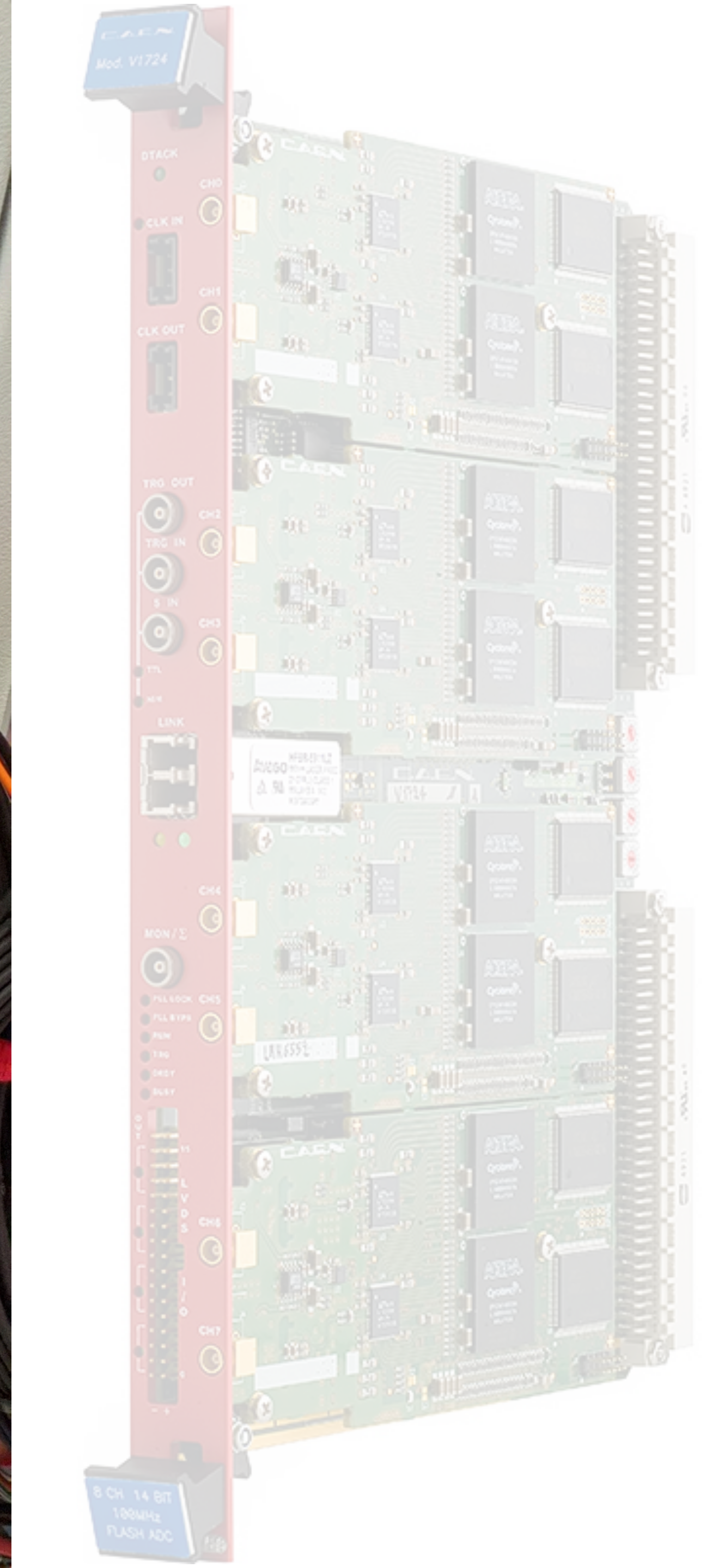
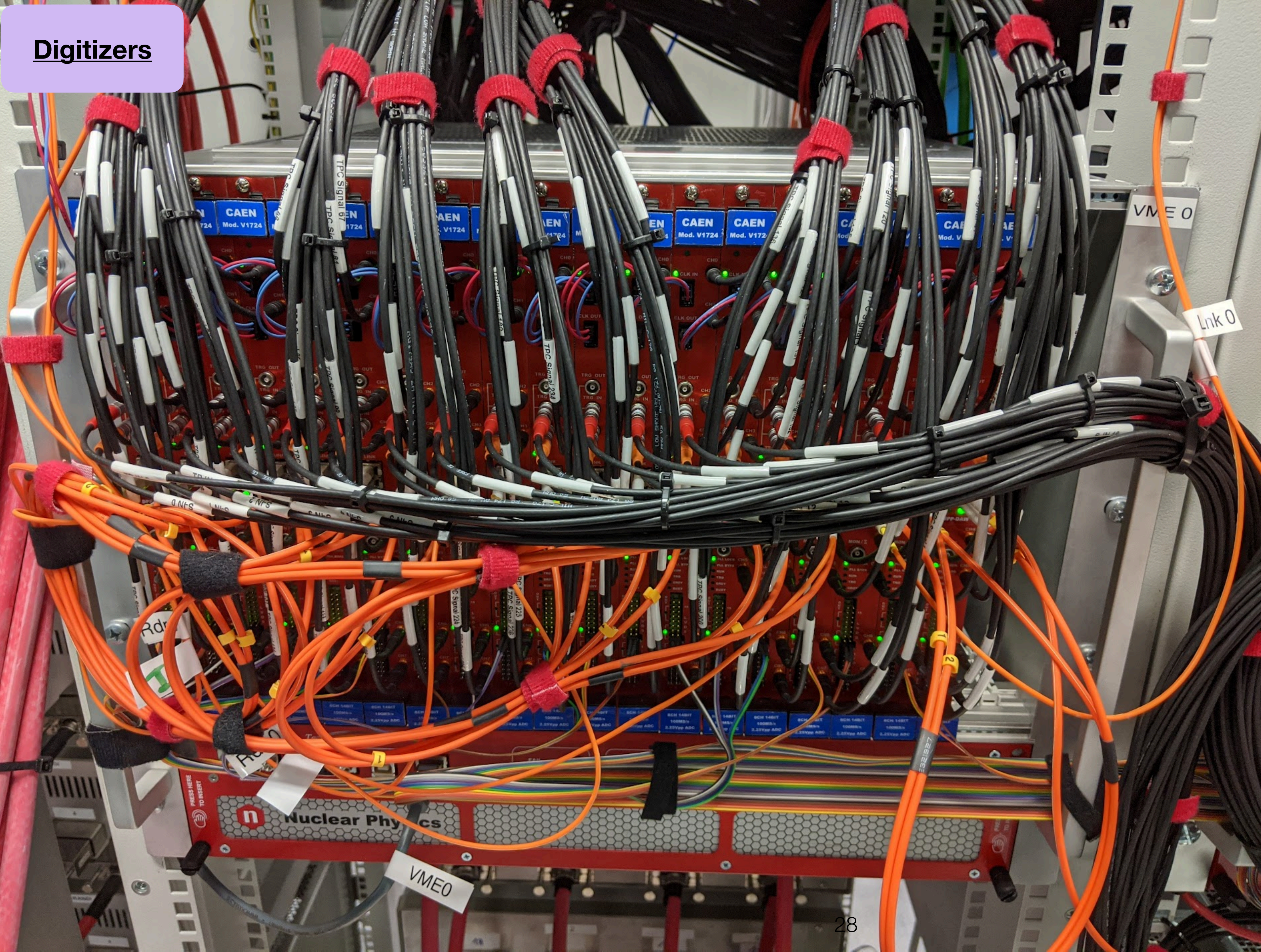

Logic

**Busy
V1495**

**Acquisition
monitor
V1724**

**HE veto
DDC10**

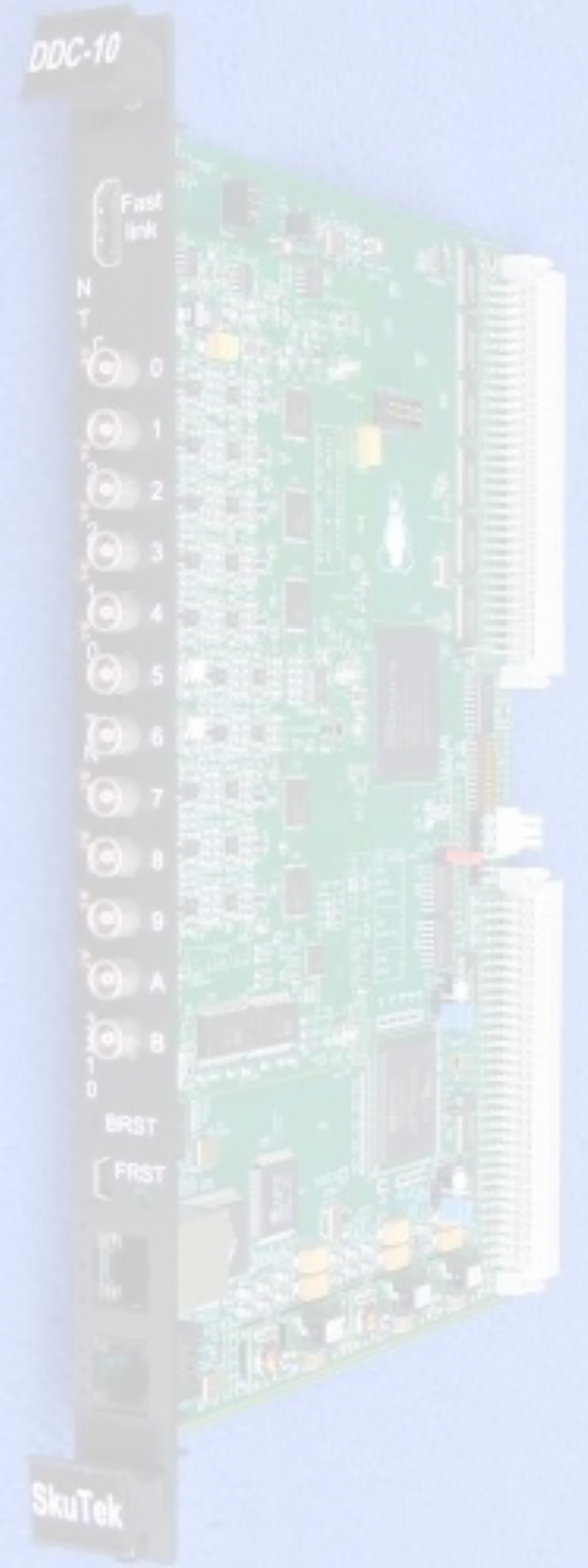
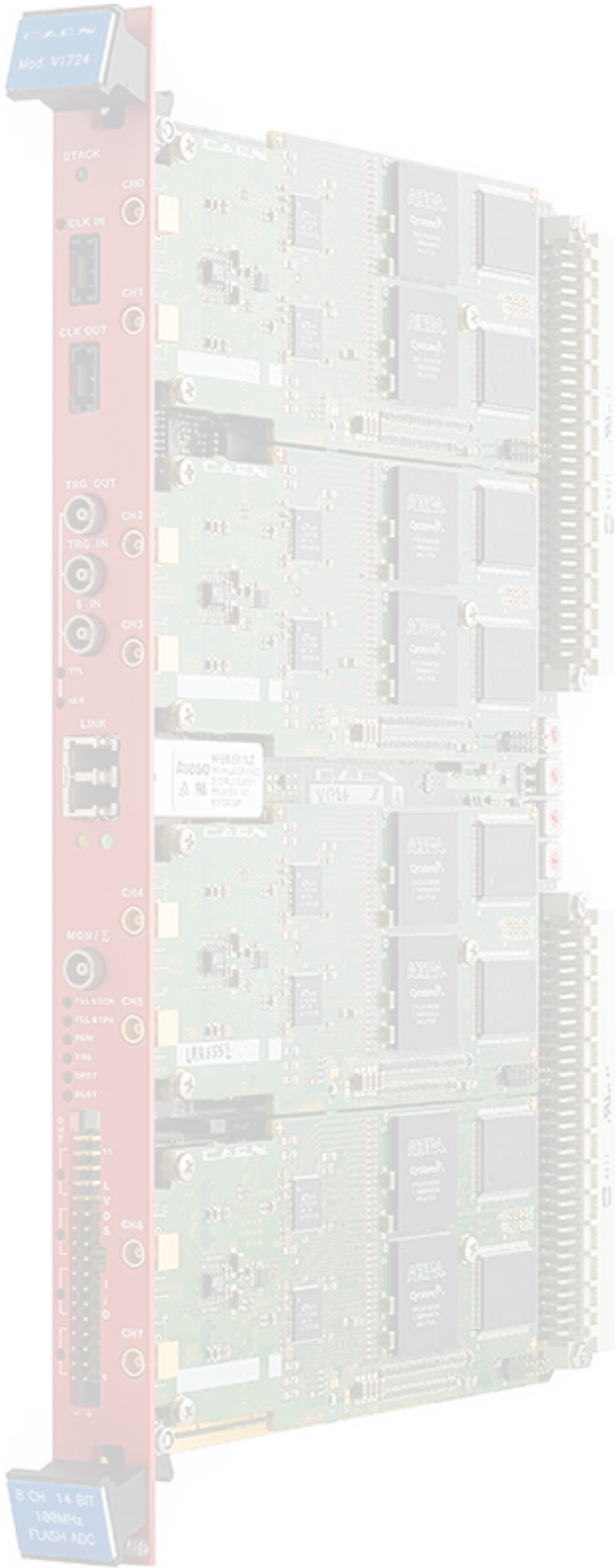
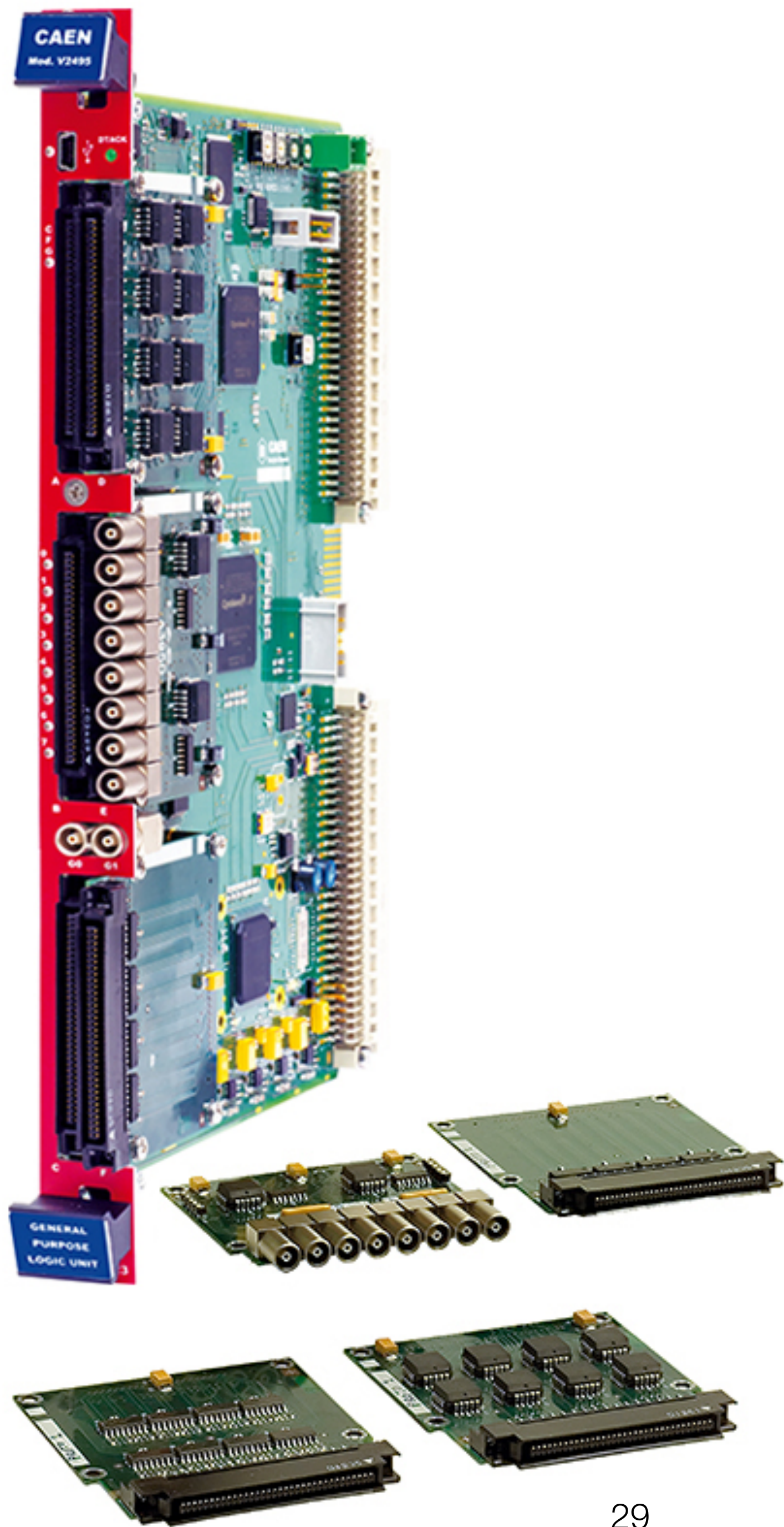

Logic

Busy
V1495

Acquisition
monitor
V1724

HE veto
DDC10

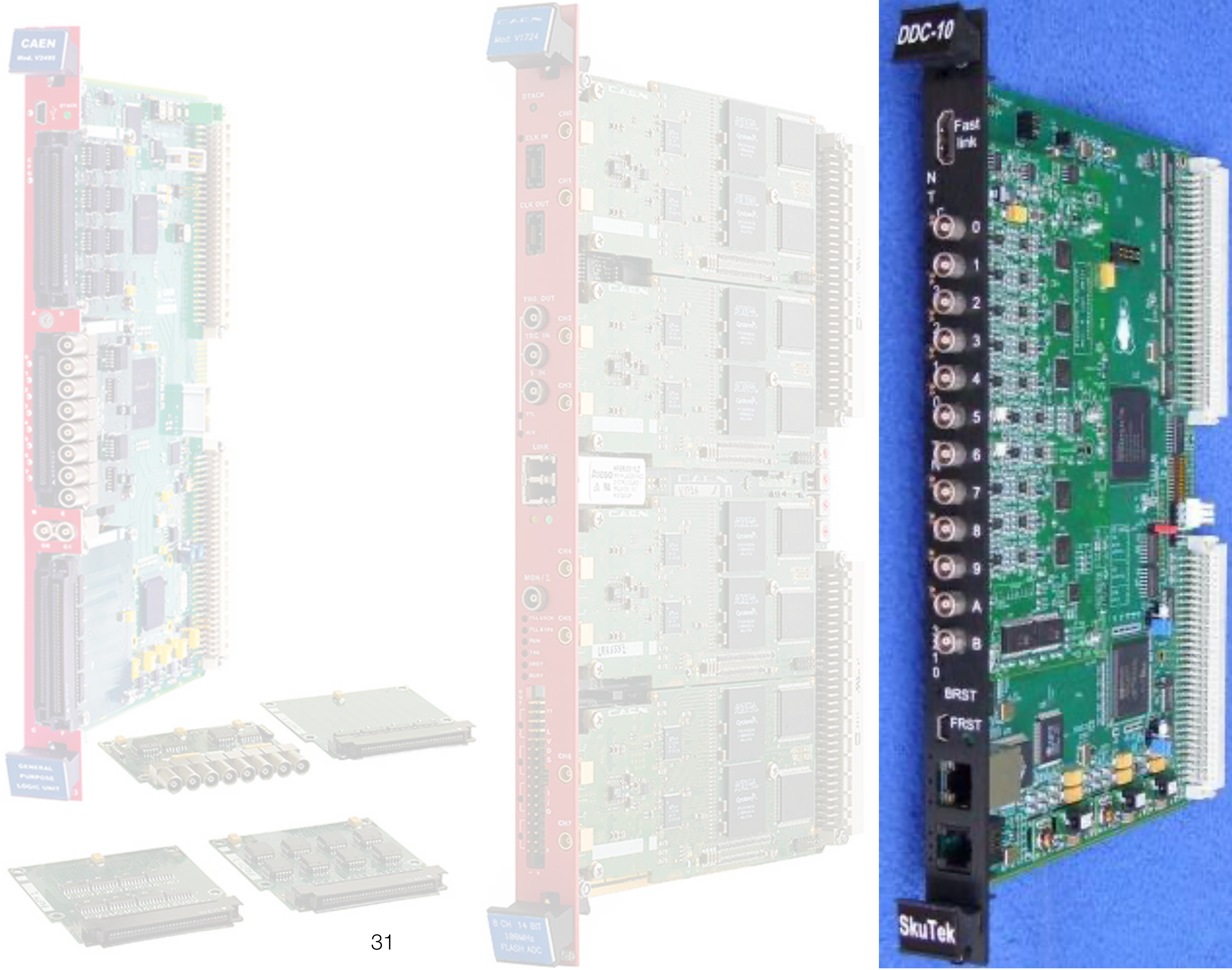

Readout

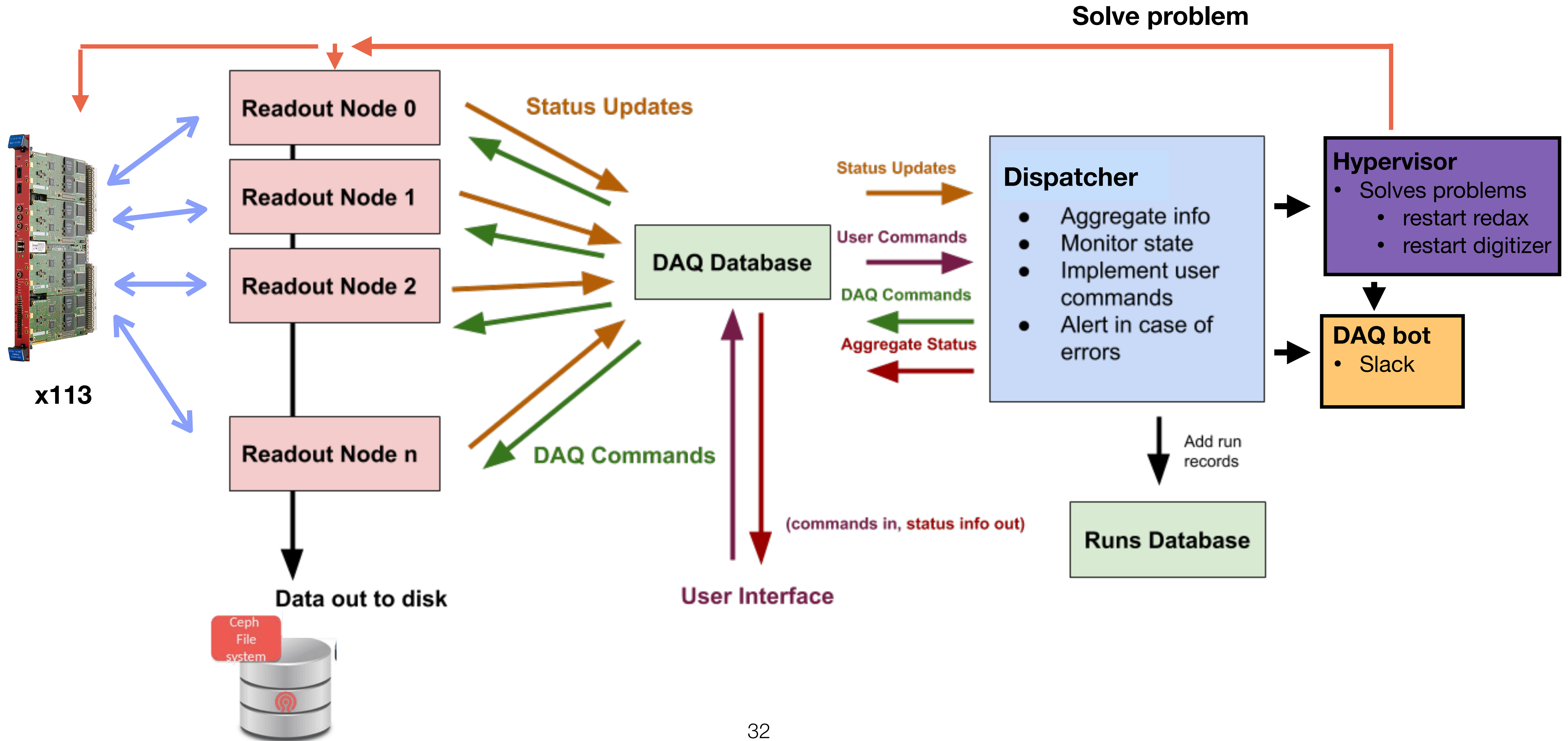

Run control

- XENON DAQ
- Overview
- Control
- Status
- Hosts
- Config
- Runs
- Monitor
- Sign Out

⚠ There are unacknowledged errors. Please go to the log page to close them

TPC Control remote Run on Soft stop off

Controller	Length (minutes)	Run Mode	Comment
gaemers	60	<input type="text"/>	<input type="text"/>

Muon Veto Control remote Run on Soft stop off

Controller	Length (minutes)	Run Mode	Comment
gaemers	60	<input type="text"/>	<input type="text"/>

Neutron Veto Control remote Run on Soft stop off

Controller	Length (minutes)	Run Mode	Comment
gaemers	60	<input type="text"/>	<input type="text"/>

LZ Control remote Run on Soft stop off

Controller	Length (minutes)	Run Mode	Comment
gaemers	60	<input type="text"/>	<input type="text"/>

```
2022-01-21 12:24:03.355607 | DEBUG | main (L65) | The xams should be INACTIVE and is IDLE
2022-01-21 12:24:06.383716 | DEBUG | main (L65) | The xams should be INACTIVE and is IDLE
2022-01-21 12:24:09.487362 | DEBUG | main (L65) | The xams should be INACTIVE and is IDLE
2022-01-21 12:24:12.425781 | DEBUG | main (L65) | The xams should be INACTIVE and is IDLE
2022-01-21 12:24:15.452754 | DEBUG | main (L65) | The xams should be INACTIVE and is IDLE
2022-01-21 12:24:18.480793 | DEBUG | main (L65) | The xams should be INACTIVE and is IDLE
2022-01-21 12:24:21.587988 | DEBUG | main (L65) | The xams should be INACTIVE and is IDLE
2022-01-21 12:24:24.532421 | DEBUG | main (L65) | The xams should be INACTIVE and is IDLE
2022-01-21 12:24:27.553738 | DEBUG | main (L65) | The xams should be INACTIVE and is IDLE
2022-01-21 12:24:30.574247 | DEBUG | main (L65) | The xams should be INACTIVE and is IDLE
2022-01-21 12:24:33.681252 | DEBUG | main (L65) | The xams should be INACTIVE and is IDLE
2022-01-21 12:24:36.625911 | DEBUG | main (L65) | The xams should be INACTIVE and is IDLE
2022-01-21 12:24:39.658321 | DEBUG | main (L65) | The xams should be INACTIVE and is IDLE
2022-01-21 12:24:42.676718 | DEBUG | main (L65) | The xams should be INACTIVE and is IDLE
2022-01-21 12:24:45.699518 | DEBUG | main (L65) | The xams should be ACTIVE and is IDLE
2022-01-21 12:24:45.699605 | INFO | solve_problem (L151) | The xams is idle, sending arm command
2022-01-21 12:24:45.701814 | DEBUG | control_detector (L247) | Sending ARM to xams
2022-01-21 12:24:45.786627 | DEBUG | send_command (L623) | Queued arm for xams. Now [{'command': 'arm', 'user': 'mfliern', 'detector': 'xams', 'mode': 'of
f_sleep', 'createdAt': datetime.datetime(2022, 1, 21, 12, 24, 45, 786583, tzinfo=UTC)}, {'options_override': {'number': 779}, 'host': ['xams-daq_reader_0'], 'acknowledged': {'xams-daq_reader_0': 0}}]
2022-01-21 12:24:48.736249 | DEBUG | main (L65) | The xams should be ACTIVE and is ARMING (779)
2022-01-21 12:24:48.736348 | INFO | solve_problem (L148) | The xams is arming, check timeouts
2022-01-21 12:24:48.736389 | DEBUG | solve_problem (L141) | Checking the xams timeouts
2022-01-21 12:24:48.736431 | DEBUG | check_timeouts (L296) | Checking arm timeout for xams
2022-01-21 12:24:48.736488 | DEBUG | check_timeouts (L384) | 3 is within the 60 second timeout for a arm command
2022-01-21 12:24:51.768964 | DEBUG | main (L65) | The xams should be ACTIVE and is ARMED (779)
2022-01-21 12:24:51.761868 | INFO | solve_problem (L136) | The xams is armed, sending start command
2022-01-21 12:24:51.762238 | DEBUG | control_detector (L247) | Sending START to xams
2022-01-21 12:24:51.762383 | DEBUG | send_command (L623) | Queued start for xams. Now [{'command': 'start', 'user': 'mfliern', 'detector': 'xams', 'mode': 'off_sleep', 'createdAt': datetime.datetime(2022, 1, 21, 12, 24, 51, 762328, tzinfo=UTC)}, {'host': ['xams-daq_reader_0'], 'acknowledged': {'xams-daq_reader_0': 0}}, {'command': 'start', 'user': 'mfliern', 'detector': 'xams', 'mode': 'off_sleep', 'createdAt': datetime.datetime(2022, 1, 21, 12, 24, 52, 762328, tzinfo=UTC)}, {'host': [], 'acknowledged': {}}]
2022-01-21 12:24:51.762641 | WARNING | process_commands (L638) | [{'command': 'start', 'user': 'mfliern', 'detector': 'xams', 'mode': 'off_sleep', 'createdAt': datetime.datetime(2022, 1, 21, 12, 24, 51, 762328, tzinfo=UTC)}, {'host': ['xams-daq_reader_0'], 'acknowledged': {'xams-daq_reader_0': 0}}, {'command': 'start', 'user': 'mfliern', 'detector': 'xams', 'mode': 'off_sleep', 'createdAt': datetime.datetime(2022, 1, 21, 12, 24, 52, 762328, tzinfo=UTC)}, {'host': [], 'acknowledged': {}}]
2022-01-21 12:24:56.792257 | DEBUG | main (L65) | The xams should be ACTIVE and is RUNNING (779)
2022-01-21 12:24:56.792348 | INFO | solve_problem (L129) | The xams is running
2022-01-21 12:24:56.794284 | DEBUG | check_run_turnover (L369) | Checking run turnover for xams: 4/60
2022-01-21 12:24:59.828987 | DEBUG | main (L65) | The xams should be ACTIVE and is RUNNING (779)
2022-01-21 12:24:59.828989 | INFO | solve_problem (L129) | The xams is running
2022-01-21 12:24:59.821843 | DEBUG | check_run_turnover (L369) | Checking run turnover for xams: 7/60
2022-01-21 12:25:02.863383 | DEBUG | main (L65) | The xams should be ACTIVE and is RUNNING (779)
2022-01-21 12:25:02.863484 | INFO | solve_problem (L129) | The xams is running
2022-01-21 12:25:02.863544 | DEBUG | check_run_turnover (L369) | Checking run turnover for xams: 11/60
2022-01-21 12:25:05.887888 | DEBUG | main (L65) | The xams should be ACTIVE and is RUNNING (779)
2022-01-21 12:25:05.888469 | INFO | solve_problem (L129) | The xams is running
2022-01-21 12:25:05.888731 | DEBUG | check_run_turnover (L369) | Checking run turnover for xams: 14/60
```

```
2021-12-03 13:39:44.621 | -1 | DEBUG | Found a doc with command arm
2021-12-03 13:39:44.621 | -1 | LOCAL | Getting options doc for mode test_run_two_digitizers
2021-12-03 13:39:44.623 | -1 | LOCAL | Using default value for baseline_reference_run
2021-12-03 13:39:44.623 | -1 | LOCAL | Using default value for baseline_fallback_mode
2021-12-03 13:39:44.623 | 2450 | LOCAL | Took 1 ms to load config
2021-12-03 13:39:44.623 | 2450 | LOCAL | Beginning electronics initialization with 1 threads
2021-12-03 13:39:44.623 | 2450 | LOCAL | Arming new digitizer 770
2021-12-03 13:39:44.623 | 2450 | LOCAL | Using default BLT allocs
2021-12-03 13:39:44.636 | 2450 | DEBUG | Board 770 initialized with handle 0 (link/crate)(0/1)
2021-12-03 13:39:44.636 | 2450 | LOCAL | Board 770 reset
2021-12-03 13:39:44.657 | 2450 | LOCAL | This host has 1 boards
2021-12-03 13:39:44.657 | 2450 | LOCAL | Sleeping for two seconds
2021-12-03 13:39:46.657 | 2450 | LOCAL | That felt great, thanks.
2021-12-03 13:39:46.658 | 2450 | DEBUG | Digitizer programming successful
2021-12-03 13:39:46.659 | 2450 | LOCAL | Using default value for transfer_batch
2021-12-03 13:39:46.659 | 2450 | LOCAL | Using default value for us_between_reads
2021-12-03 13:39:46.659 | 2450 | LOCAL | Board 770 has status 0x0180
2021-12-03 13:39:47.570 | 2450 | LOCAL | Board 770 has status 0x0180
2021-12-03 13:39:47.659 | 2450 | LOCAL | DC offset 0fa0 0fa0
2021-12-03 13:39:47.659 | 2450 | LOCAL | Arm command finished, returning to main loop
2021-12-03 13:39:47.659 | 2450 | DEBUG | Initialized electronics
2021-12-03 13:39:48.466 | 2450 | LOCAL | Board 770 has status 0x0180
2021-12-03 13:39:49.372 | 2450 | LOCAL | Board 770 has status 0x0180
2021-12-03 13:39:50.268 | 2450 | LOCAL | Board 770 has status 0x0180
2021-12-03 13:39:50.616 | 2450 | DEBUG | Found a doc with command start
2021-12-03 13:39:50.616 | 2450 | LOCAL | Wrote 0x0104 to 0x8100
2021-12-03 13:39:50.616 | 2450 | LOCAL | Wrote 0x0104 to 0x8100
2021-12-03 13:39:50.616 | 2450 | LOCAL | Ack to start took 93 us
2021-12-03 13:39:51.278 | 2450 | LOCAL | Board 770 has status 0x0184
2021-12-03 13:39:52.386 | 2450 | LOCAL | Board 770 has status 0x0184
2021-12-03 13:39:53.481 | 2450 | LOCAL | Board 770 has status 0x0184
2021-12-03 13:39:54.576 | 2450 | LOCAL | Board 770 has status 0x0184
2021-12-03 13:39:55.642 | 2450 | LOCAL | Board 770 has status 0x0184
2021-12-03 13:39:56.741 | 2450 | LOCAL | Board 770 has status 0x0184
```

Readout

There are unacknowledged errors. Please go to the log page to close them

TPC Control remote Run on Soft stop off

Controller Length (minutes) Run Mode Comment

gaemers 60

Muon Veto Control remote Run on Soft stop off

Controller Length (minutes) Run Mode Comment

gaemers 60

Neutron Veto Control remote Run on Soft stop off

Controller Length (minutes) Run Mode Comment

gaemers 60

LZ Control remote Run on Soft stop off

Controller Length (minutes) Run Mode Comment

gaemers 60

```
2022-01-21 12:24:03.355607 | DEBUG | main (L65) | The xams should be INACTIVE and is IDLE
2022-01-21 12:24:06.383716 | DEBUG | main (L65) | The xams should be INACTIVE and is IDLE
2022-01-21 12:24:09.407362 | DEBUG | main (L65) | The xams should be INACTIVE and is IDLE
2022-01-21 12:24:12.425781 | DEBUG | main (L65) | The xams should be INACTIVE and is IDLE
2022-01-21 12:24:15.452954 | DEBUG | main (L65) | The xams should be INACTIVE and is IDLE
2022-01-21 12:24:18.480793 | DEBUG | main (L65) | The xams should be INACTIVE and is IDLE
2022-01-21 12:24:21.507988 | DEBUG | main (L65) | The xams should be INACTIVE and is IDLE
2022-01-21 12:24:24.532421 | DEBUG | main (L65) | The xams should be INACTIVE and is IDLE
2022-01-21 12:24:27.553738 | DEBUG | main (L65) | The xams should be INACTIVE and is IDLE
2022-01-21 12:24:30.574247 | DEBUG | main (L65) | The xams should be INACTIVE and is IDLE
2022-01-21 12:24:33.601252 | DEBUG | main (L65) | The xams should be INACTIVE and is IDLE
2022-01-21 12:24:36.625911 | DEBUG | main (L65) | The xams should be INACTIVE and is IDLE
2022-01-21 12:24:39.650321 | DEBUG | main (L65) | The xams should be INACTIVE and is IDLE
2022-01-21 12:24:42.676718 | DEBUG | main (L65) | The xams should be INACTIVE and is IDLE
2022-01-21 12:24:45.699510 | DEBUG | main (L65) | The xams should be ACTIVE and is IDLE
2022-01-21 12:24:45.699605 | INFO | solve_problem (L151) | The xams is idle, sending arm command
2022-01-21 12:24:45.701814 | DEBUG | control_detector (L247) | Sending ARM to xams
2022-01-21 12:24:45.706627 | DEBUG | send_command (L623) | Queued arm for xams. Now [{'command': 'arm', 'user': 'mflierm', 'detector': 'xams', 'mode': 'off_sleep', 'createdAt': datetime.datetime(2022, 1, 21, 12, 24, 45, 706503, tzinfo=<UTC>), 'options_override': {'number': 779}, 'host': ['xams-daq_reader_0'], 'acknowledged': {'xams-daq_reader_0': 0}}]
2022-01-21 12:24:48.736249 | DEBUG | main (L65) | The xams should be ACTIVE and is ARMING (779)
2022-01-21 12:24:48.736348 | INFO | solve_problem (L140) | The xams is arming, check timeouts
2022-01-21 12:24:48.736389 | DEBUG | solve_problem (L141) | Checking the xams timeouts
2022-01-21 12:24:48.736431 | DEBUG | check_timeouts (L296) | Checking arm timeout for xams
2022-01-21 12:24:48.736480 | DEBUG | check_timeouts (L304) | 3 is within the 60 second timeout for a arm command
2022-01-21 12:24:51.760964 | DEBUG | main (L65) | The xams should be ACTIVE and is ARMED (779)
2022-01-21 12:24:51.761060 | INFO | solve_problem (L136) | The xams is armed, sending start command
2022-01-21 12:24:51.762230 | DEBUG | control_detector (L247) | Sending START to xams
2022-01-21 12:24:51.762383 | DEBUG | send_command (L623) | Queued start for xams. Now [{'command': 'start', 'user': 'mflierm', 'detector': 'xams', 'mode': 'off_sleep', 'createdAt': datetime.datetime(2022, 1, 21, 12, 24, 51, 762328, tzinfo=<UTC>), 'host': ['xams-daq_reader_0'], 'acknowledged': {'xams-daq_reader_0': 0}}, {'command': 'start', 'user': 'mflierm', 'detector': 'xams', 'mode': 'off_sleep', 'createdAt': datetime.datetime(2022, 1, 21, 12, 24, 52, 762328, tzinfo=<UTC>), 'host': [], 'acknowledged': {}}]
2022-01-21 12:24:51.762641 | WARNING | process_commands (L638) | [{'command': 'start', 'user': 'mflierm', 'detector': 'xams', 'mode': 'off_sleep', 'createdAt': datetime.datetime(2022, 1, 21, 12, 24, 51, 762328, tzinfo=<UTC>), 'host': ['xams-daq_reader_0'], 'acknowledged': {'xams-daq_reader_0': 0}}, {'command': 'start', 'user': 'mflierm', 'detector': 'xams', 'mode': 'off_sleep', 'createdAt': datetime.datetime(2022, 1, 21, 12, 24, 52, 762328, tzinfo=<UTC>), 'host': [], 'acknowledged': {}}]
2022-01-21 12:24:56.792257 | DEBUG | main (L65) | The xams should be ACTIVE and is RUNNING (779)
2022-01-21 12:24:56.792348 | INFO | solve_problem (L129) | The xams is running
2022-01-21 12:24:56.794204 | DEBUG | check_run_turnover (L369) | Checking run turnover for xams: 4/60
2022-01-21 12:24:59.820907 | DEBUG | main (L65) | The xams should be ACTIVE and is RUNNING (779)
2022-01-21 12:24:59.820989 | INFO | solve_problem (L129) | The xams is running
2022-01-21 12:24:59.821043 | DEBUG | check_run_turnover (L369) | Checking run turnover for xams: 7/60
2022-01-21 12:25:02.863383 | DEBUG | main (L65) | The xams should be ACTIVE and is RUNNING (779)
2022-01-21 12:25:02.863484 | INFO | solve_problem (L129) | The xams is running
2022-01-21 12:25:02.863544 | DEBUG | check_run_turnover (L369) | Checking run turnover for xams: 11/60
2022-01-21 12:25:05.887808 | DEBUG | main (L65) | The xams should be ACTIVE and is RUNNING (779)
2022-01-21 12:25:05.888469 | INFO | solve_problem (L129) | The xams is running
2022-01-21 12:25:05.888731 | DEBUG | check_run_turnover (L369) | Checking run turnover for xams: 14/60
2021-12-03 13:39:44.636 | 2450 | DEBUG | Board 770 initialized with handle 0 (link/crate)0/1
2021-12-03 13:39:44.636 | 2450 | LOCAL | Board 770 reset
2021-12-03 13:39:44.657 | 2450 | LOCAL | This host has 1 boards
2021-12-03 13:39:44.657 | 2450 | LOCAL | Sleeping for two seconds
2021-12-03 13:39:46.657 | 2450 | LOCAL | That felt great, thanks.
2021-12-03 13:39:46.658 | 2450 | DEBUG | Digitizer programming successful
2021-12-03 13:39:46.659 | 2450 | LOCAL | Using default value for transfer_batch
2021-12-03 13:39:46.659 | 2450 | LOCAL | Using default value for us_between_reads
2021-12-03 13:39:46.659 | 2450 | LOCAL | Board 770 has status 0x0180
2021-12-03 13:39:47.570 | 2450 | LOCAL | Board 770 has status 0x0180
2021-12-03 13:39:47.659 | 2450 | LOCAL | DC offset 0fa0 0fa0
2021-12-03 13:39:47.659 | 2450 | LOCAL | Arm command finished, returning to main loop
2021-12-03 13:39:47.659 | 2450 | DEBUG | Initialized electronics
2021-12-03 13:39:48.466 | 2450 | LOCAL | Board 770 has status 0x0180
2021-12-03 13:39:49.372 | 2450 | LOCAL | Board 770 has status 0x0180
2021-12-03 13:39:50.268 | 2450 | LOCAL | Board 770 has status 0x0180
2021-12-03 13:39:50.616 | 2450 | DEBUG | Found a doc with command start
2021-12-03 13:39:50.616 | 2450 | LOCAL | Wrote 0x0104 to 0x8100
2021-12-03 13:39:50.616 | 2450 | LOCAL | Wrote 0x0104 to 0x8100
2021-12-03 13:39:50.616 | 2450 | LOCAL | Ack to start took 93 us
2021-12-03 13:39:51.278 | 2450 | LOCAL | Board 770 has status 0x0184
2021-12-03 13:39:52.386 | 2450 | LOCAL | Board 770 has status 0x0184
2021-12-03 13:39:53.481 | 2450 | LOCAL | Board 770 has status 0x0184
2021-12-03 13:39:54.576 | 2450 | LOCAL | Board 770 has status 0x0184
2021-12-03 13:39:55.642 | 2450 | LOCAL | Board 770 has status 0x0184
2021-12-03 13:39:56.741 | 2450 | LOCAL | Board 770 has status 0x0184
```

Readout

There are unacknowledged errors. Please go to the log page to close them

TPC Control remote Run on Soft stop off

Controller: gaemers Length (minutes): 60 Run Mode: Comment:

Muon Veto Control remote Run on Soft stop off

Controller: gaemers Length (minutes): 60 Run Mode: Comment:

Neutron Veto Control remote Run on Soft stop off

Controller: gaemers Length (minutes): 60 Run Mode: Comment:

LZ Control remote Run on Soft stop off

Controller: gaemers Length (minutes): 60 Run Mode: Comment:

```
2022-01-21 12:24:03.355607 DEBUG | main (L65) | The xams should be INACTIVE and is IDLE
2022-01-21 12:24:06.383716 DEBUG | main (L65) | The xams should be INACTIVE and is IDLE
2022-01-21 12:24:09.407362 DEBUG | main (L65) | The xams should be INACTIVE and is IDLE
2022-01-21 12:24:12.425781 DEBUG | main (L65) | The xams should be INACTIVE and is IDLE
2022-01-21 12:24:16.452954 DEBUG | main (L65) | The xams should be INACTIVE and is IDLE
2022-01-21 12:24:18.480793 DEBUG | main (L65) | The xams should be INACTIVE and is IDLE
2022-01-21 12:24:21.507988 DEBUG | main (L65) | The xams should be INACTIVE and is IDLE
2022-01-21 12:24:24.532421 DEBUG | main (L65) | The xams should be INACTIVE and is IDLE
2022-01-21 12:24:27.553738 DEBUG | main (L65) | The xams should be INACTIVE and is IDLE
2022-01-21 12:24:30.574247 DEBUG | main (L65) | The xams should be INACTIVE and is IDLE
2022-01-21 12:24:33.601252 DEBUG | main (L65) | The xams should be INACTIVE and is IDLE
2022-01-21 12:24:36.625911 DEBUG | main (L65) | The xams should be INACTIVE and is IDLE
2022-01-21 12:24:39.650321 DEBUG | main (L65) | The xams should be INACTIVE and is IDLE
2022-01-21 12:24:42.676718 DEBUG | main (L65) | The xams should be INACTIVE and is IDLE
2022-01-21 12:24:45.695510 DEBUG | main (L65) | The xams should be ACTIVE and is IDLE
2022-01-21 12:24:45.695686 INFO | solve_problem (L151) | The xams is idle, sending arm command
2022-01-21 12:24:45.701814 DEBUG | control_detector (L247) | Sending ARM to xams
2022-01-21 12:24:45.709627 DEBUG | send_command (L623) | Queued arm for xams. Now [{"command": "arm", "user": "mfliern", "detector": "xams", "mode": "of
f_sleep", "createdAt": datetime.datetime(2022, 1, 21, 12, 24, 45, 706583, tzinfo=UTC), "options_override": {"number": 779}, "host": ["xams-daq_reader_0"], "
acknowledged": {"xams-daq_reader_0": 0}}]
2022-01-21 12:24:48.736249 DEBUG | main (L65) | The xams should be ACTIVE and is ARMING (779)
2022-01-21 12:24:48.736348 INFO | solve_problem (L140) | The xams is arming, check timeouts
2022-01-21 12:24:48.736389 DEBUG | solve_problem (L141) | Checking the xams timeouts
2022-01-21 12:24:48.736431 DEBUG | check_timeouts (L296) | Checking arm timeout for xams
2022-01-21 12:24:48.736480 DEBUG | check_timeouts (L304) | 3 is within the 60 second timeout for a arm command
2022-01-21 12:24:48.749954 DEBUG | main (L65) | The xams should be ACTIVE and is ARMED (779)
2022-01-21 12:24:51.761860 INFO | solve_problem (L136) | The xams is armed, sending start command
2022-01-21 12:24:51.762230 DEBUG | control_detector (L247) | Sending START to xams
2022-01-21 12:24:51.762383 DEBUG | send_command (L623) | Queued start for xams. Now [{"command": "start", "user": "mfliern", "detector": "xams", "mode":
"off_sleep", "createdAt": datetime.datetime(2022, 1, 21, 12, 24, 51, 762328, tzinfo=UTC), "host": ["xams-daq_reader_0"], "acknowledged": {"xams-daq_reader_0": 0}}]
```

```
2021-12-03 13:39:44.621 | -1 | DEBUG | Found a doc with command arm
2021-12-03 13:39:44.621 | -1 | LOCAL | Getting options doc for mode test_run_two_digitizers
2021-12-03 13:39:44.623 | -1 | LOCAL | Using default value for baseline_reference_run
2021-12-03 13:39:44.623 | -1 | LOCAL | Using default value for baseline_fallback_mode
2021-12-03 13:39:44.623 | 2450 | LOCAL | Took 1 ms to load config
2021-12-03 13:39:44.623 | 2450 | LOCAL | Beginning electronics initialization with 1 threads
2021-12-03 13:39:44.623 | 2450 | LOCAL | Arming new digitizer 770
2021-12-03 13:39:44.636 | 2450 | DEBUG | Board 770 initialized with handle 0 (link/crate)(0/1)
2021-12-03 13:39:44.636 | 2450 | LOCAL | Board 770 reset
2021-12-03 13:39:44.657 | 2450 | LOCAL | This host has 1 boards
2021-12-03 13:39:44.657 | 2450 | LOCAL | Sleeping for two seconds
2021-12-03 13:39:46.657 | 2450 | LOCAL | That felt great, thanks.
2021-12-03 13:39:46.658 | 2450 | DEBUG | Digitizer programming successful
2021-12-03 13:39:46.659 | 2450 | LOCAL | Using default value for transfer_batch
2021-12-03 13:39:46.659 | 2450 | LOCAL | Using default value for us_between_reads
2021-12-03 13:39:46.659 | 2450 | LOCAL | Board 770 has status 0x0180
2021-12-03 13:39:47.570 | 2450 | LOCAL | Board 770 has status 0x0180
2021-12-03 13:39:47.659 | 2450 | LOCAL | DC offset 0fa0 0fa0
2021-12-03 13:39:47.659 | 2450 | LOCAL | Arm command finished, returning to main loop
2021-12-03 13:39:47.659 | 2450 | DEBUG | Initialized electronics
2021-12-03 13:39:48.466 | 2450 | LOCAL | Board 770 has status 0x0180
2021-12-03 13:39:49.372 | 2450 | LOCAL | Board 770 has status 0x0180
2021-12-03 13:39:50.268 | 2450 | LOCAL | Board 770 has status 0x0180
2021-12-03 13:39:50.616 | 2450 | DEBUG | Found a doc with command start
2021-12-03 13:39:50.616 | 2450 | LOCAL | Wrote 0x0104 to 0x8100
2021-12-03 13:39:50.616 | 2450 | LOCAL | Wrote 0x0104 to 0x8100
2021-12-03 13:39:50.616 | 2450 | LOCAL | Ack to start took 93 us
2021-12-03 13:39:51.278 | 2450 | LOCAL | Board 770 has status 0x0184
2021-12-03 13:39:52.386 | 2450 | LOCAL | Board 770 has status 0x0184
2021-12-03 13:39:53.481 | 2450 | LOCAL | Board 770 has status 0x0184
2021-12-03 13:39:54.576 | 2450 | LOCAL | Board 770 has status 0x0184
2021-12-03 13:39:55.642 | 2450 | LOCAL | Board 770 has status 0x0184
2021-12-03 13:39:56.741 | 2450 | LOCAL | Board 770 has status 0x0184
```

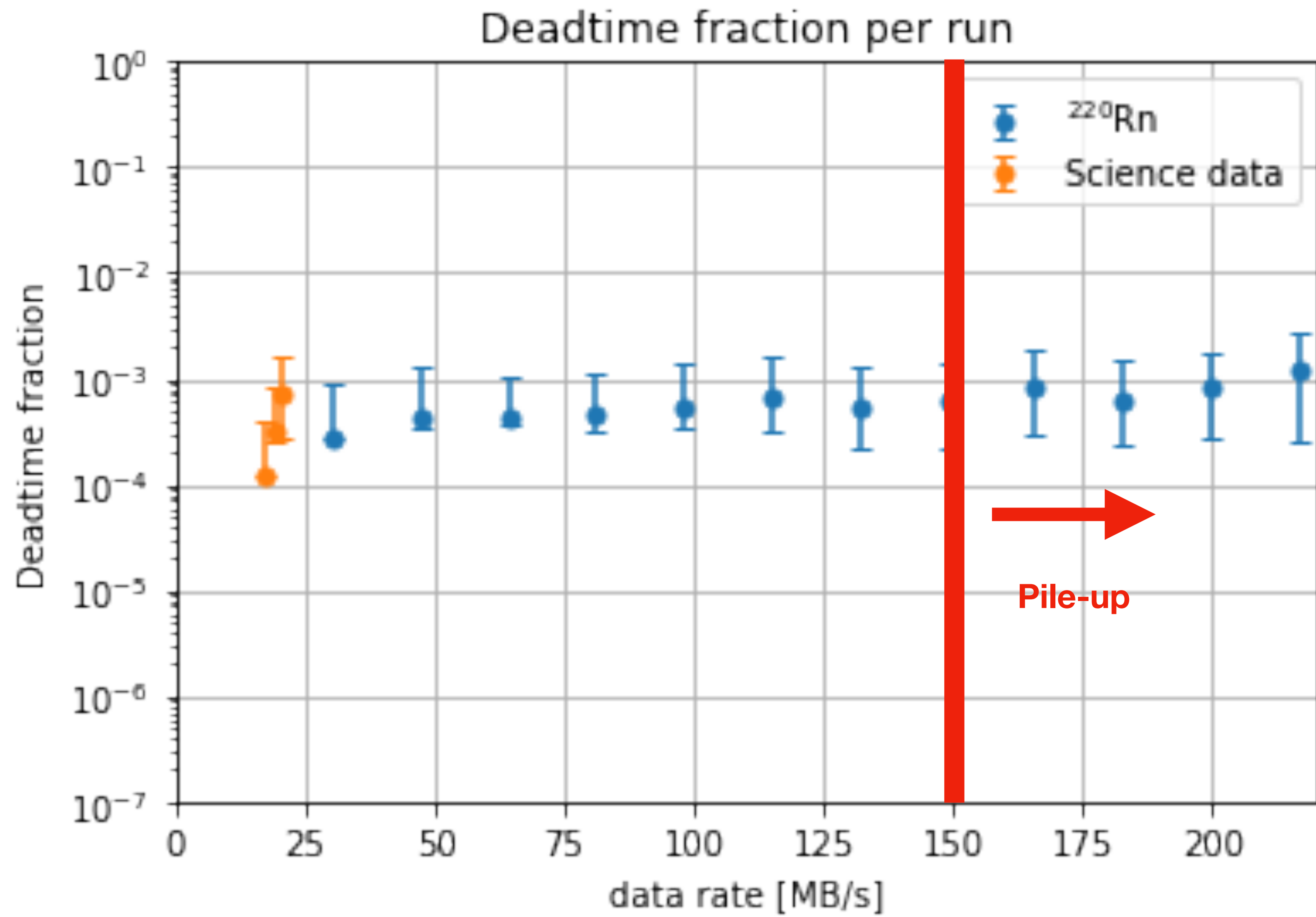

Processing

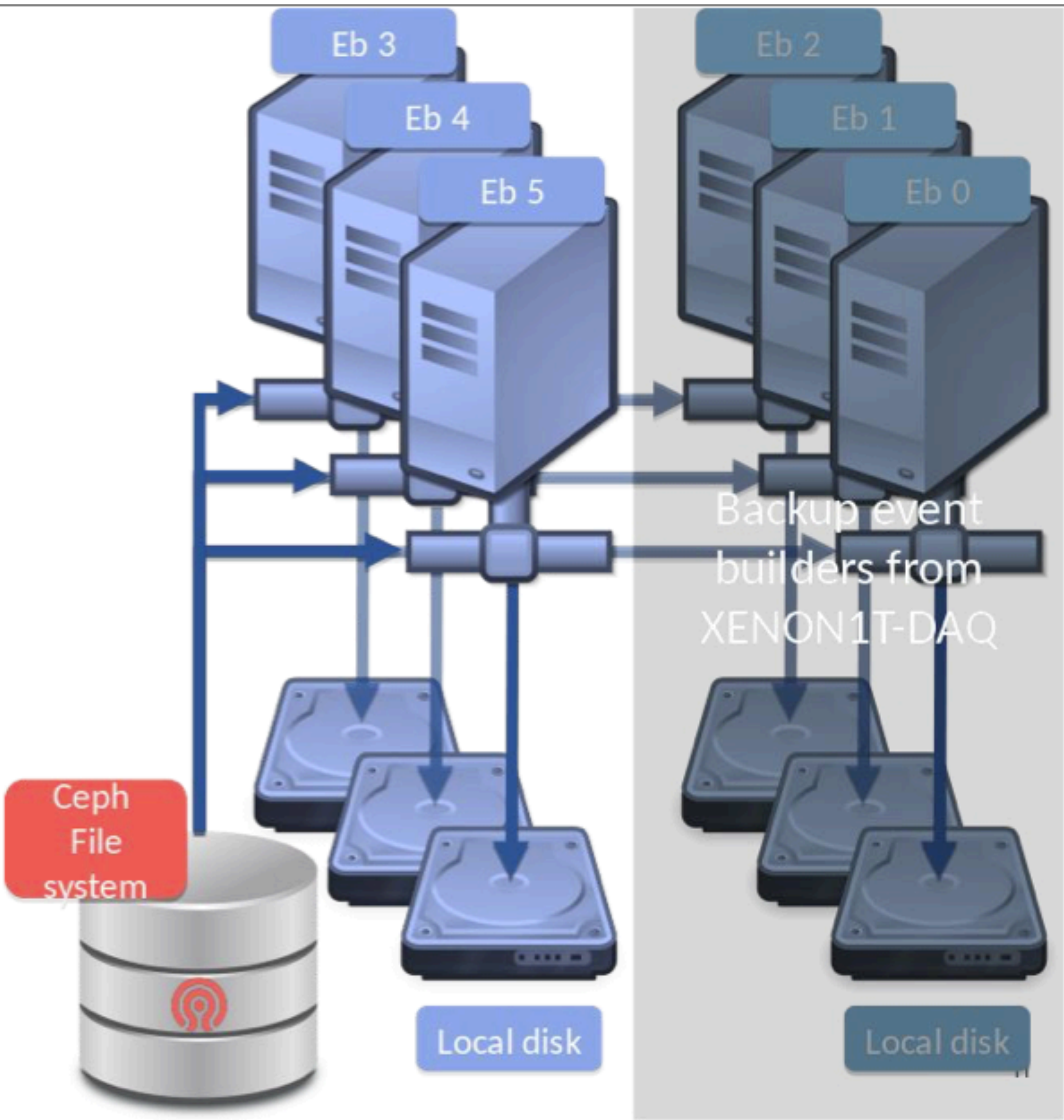

```

2022-01-20 13:46:25.175169 INFO eb_can_process (L718) | running: 2 busy: 0 queue: 0
2022-01-20 13:46:25.178507 INFO cleanup_db (L1602) | Checking for bad stuff in database
2022-01-20 13:46:25.688711 INFO main_loop (L435) | No work to do, waiting for new runs or retry timers
2022-01-20 13:46:35.701777 INFO main_loop (L386) | bootstrax running for 12388 seconds
2022-01-20 13:46:35.702234 DEBUG sufficient_diskspace (L857) | Check disk space: 5.2% full
2022-01-20 13:46:35.702371 INFO main_loop (L389) | Looking for work
2022-01-20 13:46:35.714508 INFO eb_can_process (L718) | running: 2 busy: 0 queue: 0
2022-01-20 13:46:35.717822 INFO main_loop (L435) | No work to do, waiting for new runs or retry timers
2022-01-20 13:46:45.731050 INFO main_loop (L386) | bootstrax running for 12398 seconds
2022-01-20 13:46:45.731249 DEBUG sufficient_diskspace (L857) | Check disk space: 5.2% full
2022-01-20 13:46:45.731361 INFO main_loop (L389) | Looking for work
2022-01-20 13:46:45.743379 INFO eb_can_process (L718) | running: 2 busy: 0 queue: 0
2022-01-20 13:46:45.746480 INFO main_loop (L435) | No work to do, waiting for new runs or retry timers
2022-01-20 13:46:55.759373 INFO main_loop (L386) | bootstrax running for 12408 seconds
2022-01-20 13:46:55.759561 DEBUG sufficient_diskspace (L857) | Check disk space: 5.2% full
2022-01-20 13:46:55.759656 INFO main_loop (L389) | Looking for work
2022-01-20 13:46:55.771796 INFO eb_can_process (L718) | running: 2 busy: 0 queue: 0
2022-01-20 13:46:55.775038 INFO main_loop (L435) | No work to do, waiting for new runs or retry timers
2022-01-20 13:47:05.787758 INFO main_loop (L386) | bootstrax running for 12418 seconds
    
```

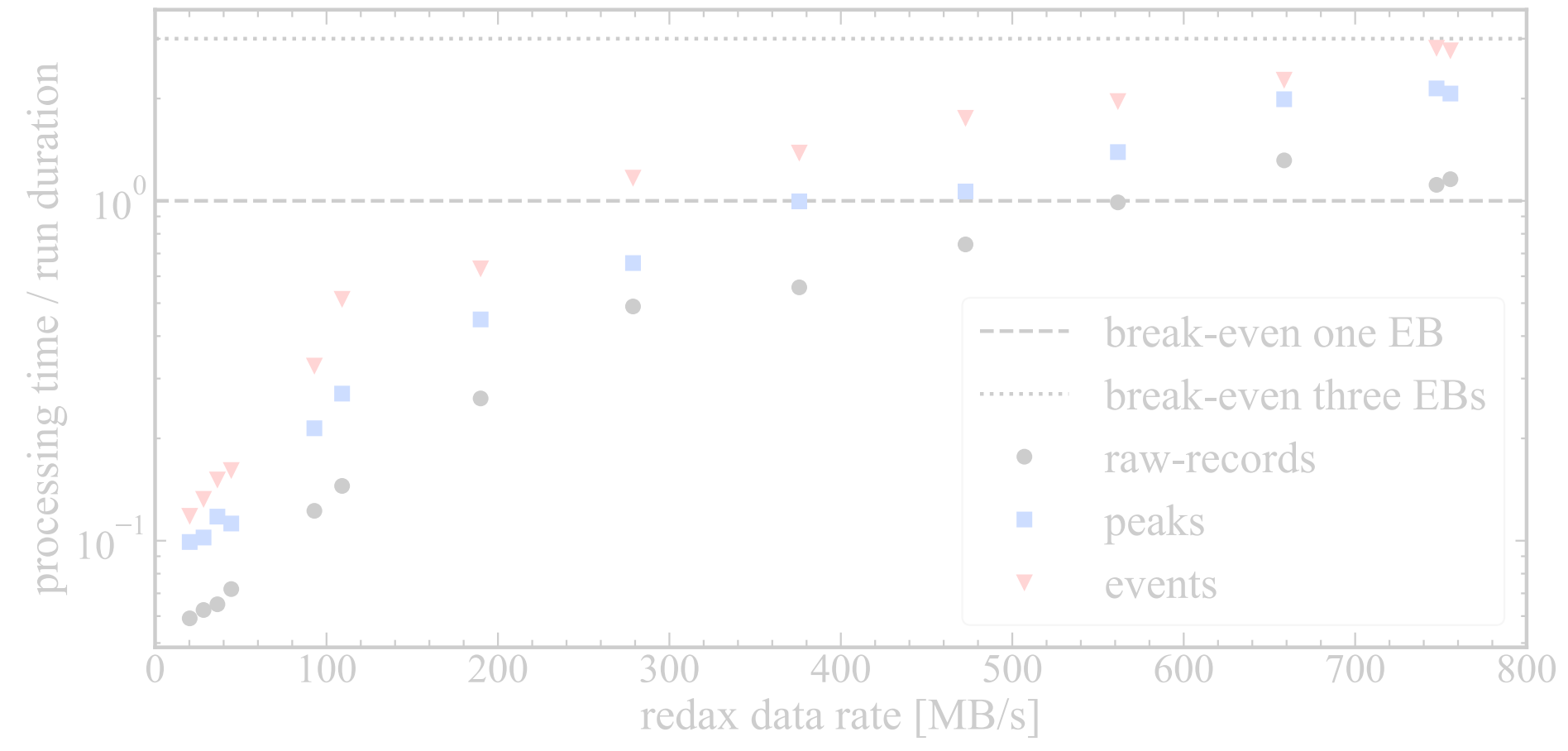

Processing

```
2022-01-20 13:46:25.175169 | INFO | eb_can_process (L718) | running: 2      busy: 0 queue: 0
2022-01-20 13:46:25.178507 | INFO | cleanup_db (L1602)  | Checking for bad stuff in database
2022-01-20 13:46:25.688711 | INFO | main_loop (L435)   | No work to do, waiting for new runs or retry timers
2022-01-20 13:46:35.701777 | INFO | main_loop (L386)   | bootstrax running for 12388 seconds
2022-01-20 13:46:35.702234 | DEBUG| sufficient_diskspace (L857) | Check disk space: 5.2% full
2022-01-20 13:46:35.702371 | INFO | main_loop (L389)   | Looking for work
2022-01-20 13:46:35.714508 | INFO | eb_can_process (L718) | running: 2      busy: 0 queue: 0
2022-01-20 13:46:35.717822 | INFO | main_loop (L435)   | No work to do, waiting for new runs or retry timers
2022-01-20 13:46:45.731050 | INFO | main_loop (L386)   | bootstrax running for 12398 seconds
2022-01-20 13:46:45.731249 | DEBUG| sufficient_diskspace (L857) | Check disk space: 5.2% full
2022-01-20 13:46:45.731361 | INFO | main_loop (L389)   | Looking for work
2022-01-20 13:46:45.743379 | INFO | eb_can_process (L718) | running: 2      busy: 0 queue: 0
2022-01-20 13:46:45.746480 | INFO | main_loop (L435)   | No work to do, waiting for new runs or retry timers
2022-01-20 13:46:55.759373 | INFO | main_loop (L386)   | bootstrax running for 12408 seconds
2022-01-20 13:46:55.759561 | DEBUG| sufficient_diskspace (L857) | Check disk space: 5.2% full
2022-01-20 13:46:55.759656 | INFO | main_loop (L389)   | Looking for work
2022-01-20 13:46:55.771796 | INFO | eb_can_process (L718) | running: 2      busy: 0 queue: 0
2022-01-20 13:46:55.775038 | INFO | main_loop (L435)   | No work to do, waiting for new runs or retry timers
2022-01-20 13:47:05.787758 | INFO | main_loop (L386)   | bootstrax running for 12418 seconds
```

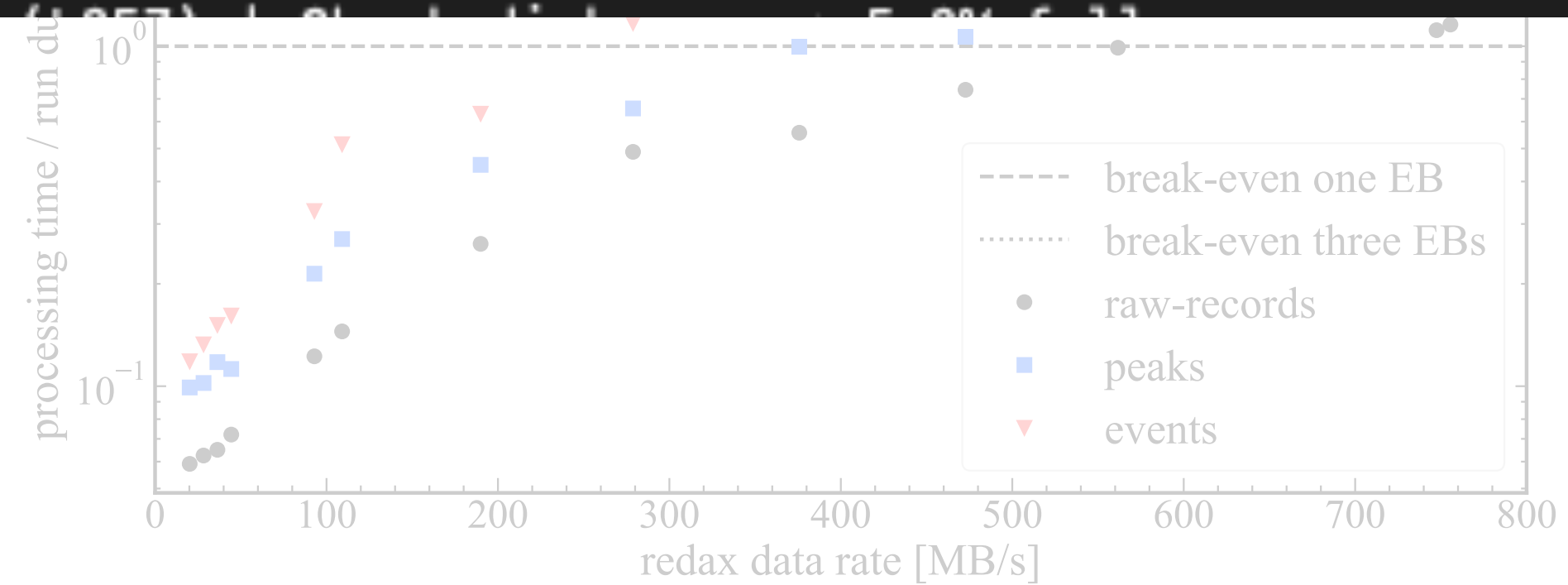
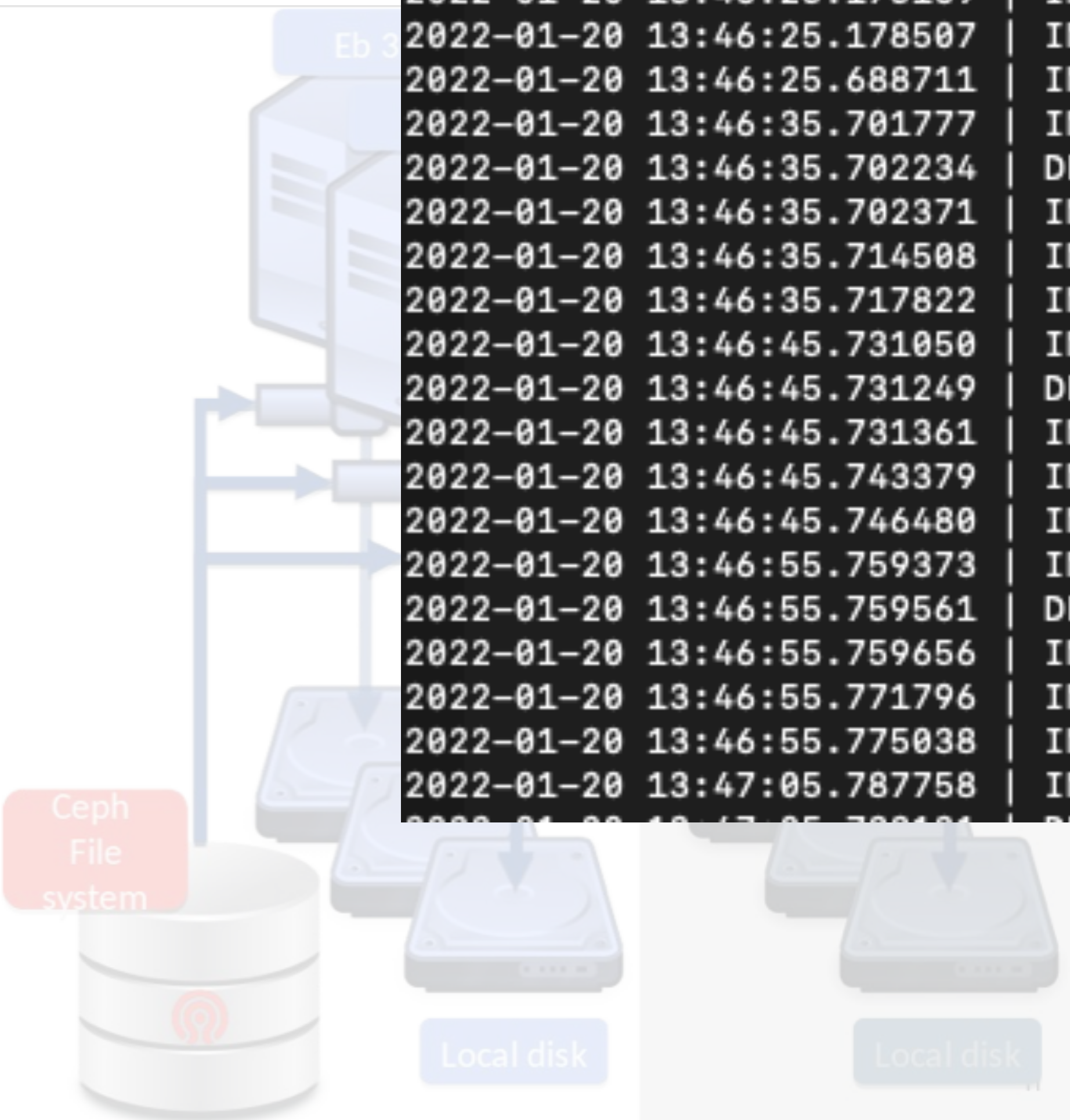

Processing

XENON1T Pax

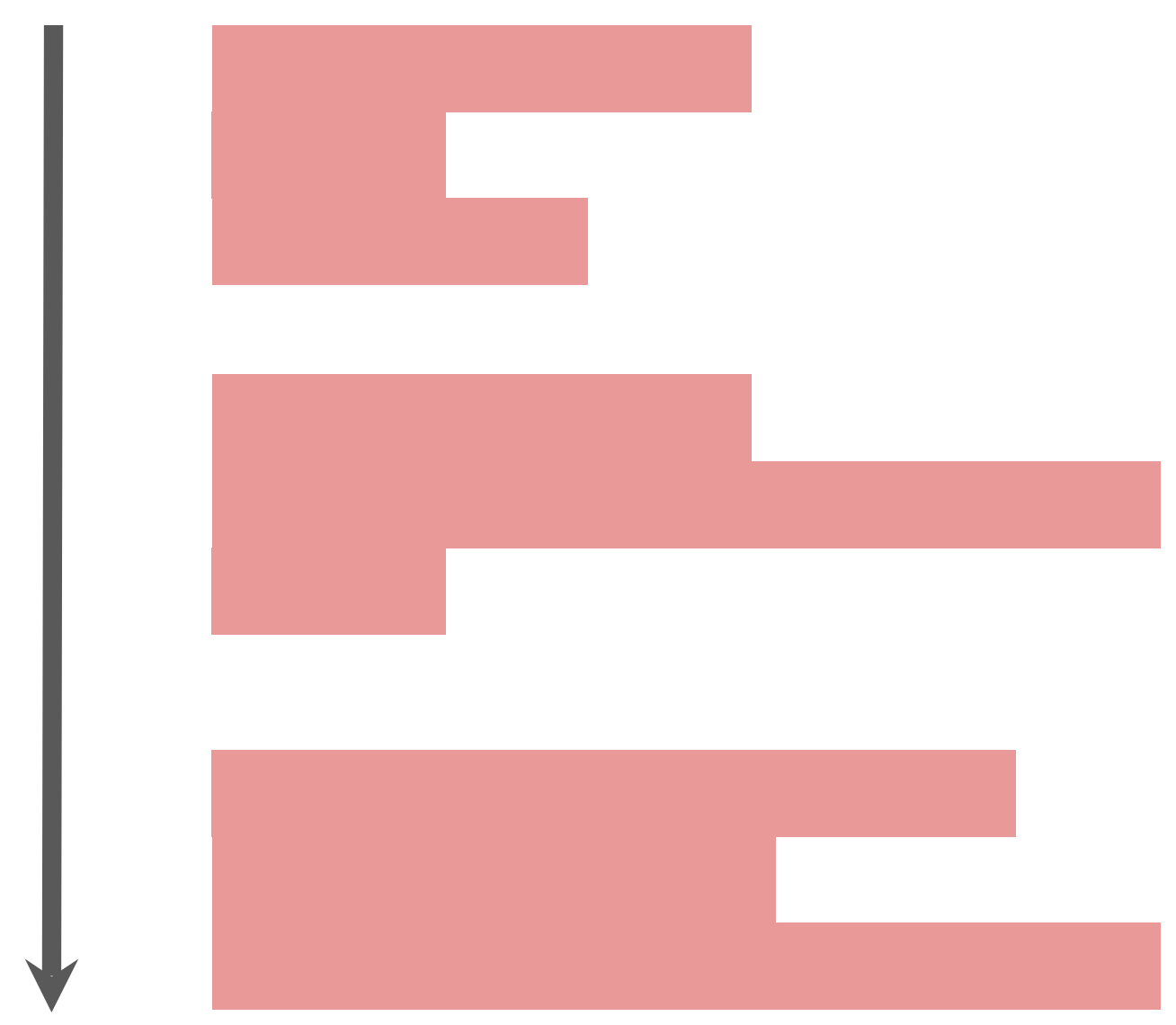

List of event classes

XENONnT Strax

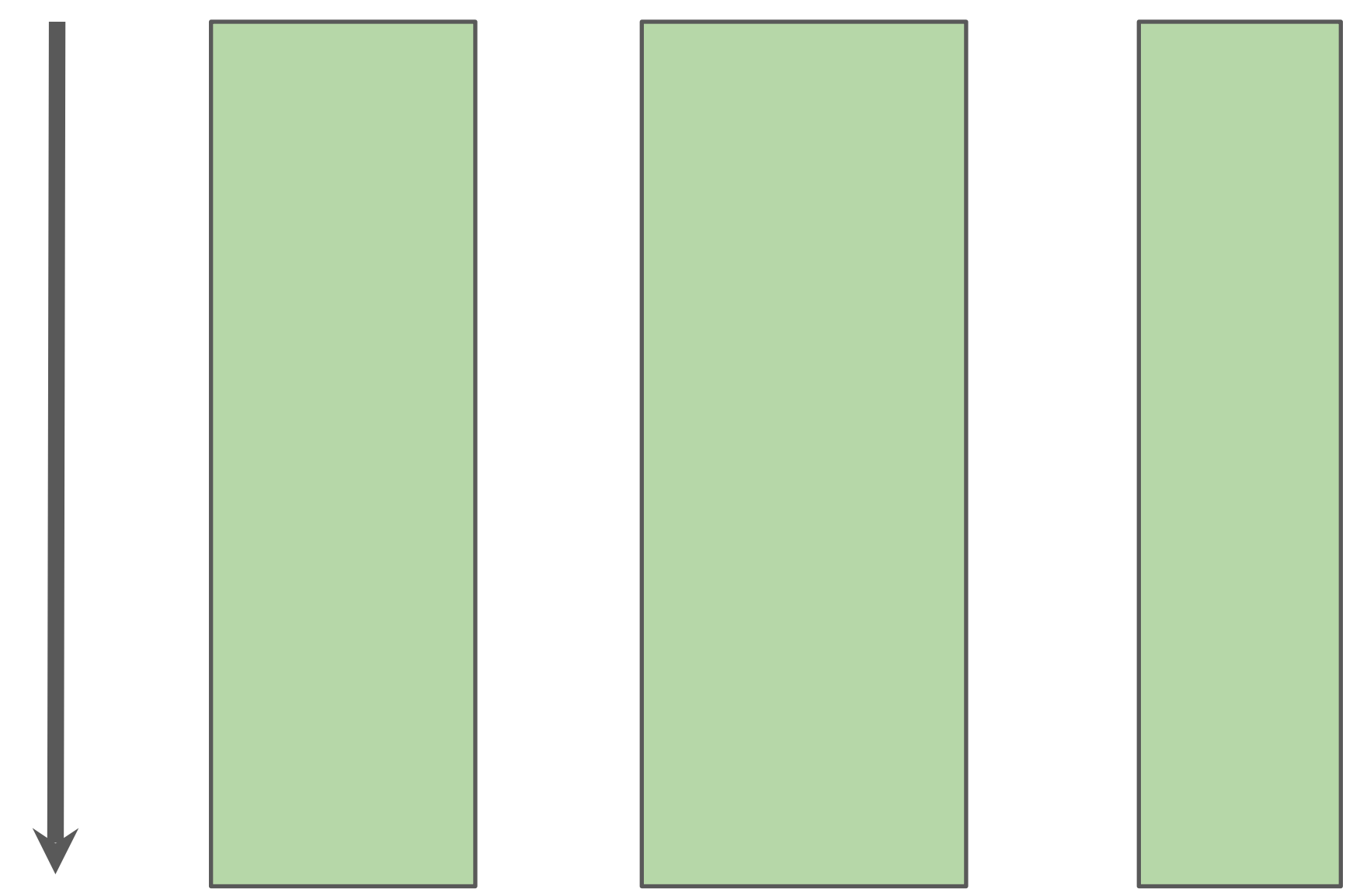

Tables indexed by time
“Array-Oriented Computing”

Table 1. Rate of processing a “query sized” payload: filling one histogram of jet p_T for all jets in a $t\bar{t}$ sample, illustrating the orders of magnitude lost to providing a full framework for heavy event processing (all single-threaded).

0.018 MHz	full framework (CMSSW, single-threaded C++)
0.029 MHz	load all 95 jet branches in ROOT
2.8 MHz	load jet p_T branch (and no others) in ROOT
12 MHz	allocate C++ objects on heap, fill, delete
31 MHz	allocate C++ objects on stack, fill histogram
250 MHz	minimal “for” loop in memory (single-threaded C)

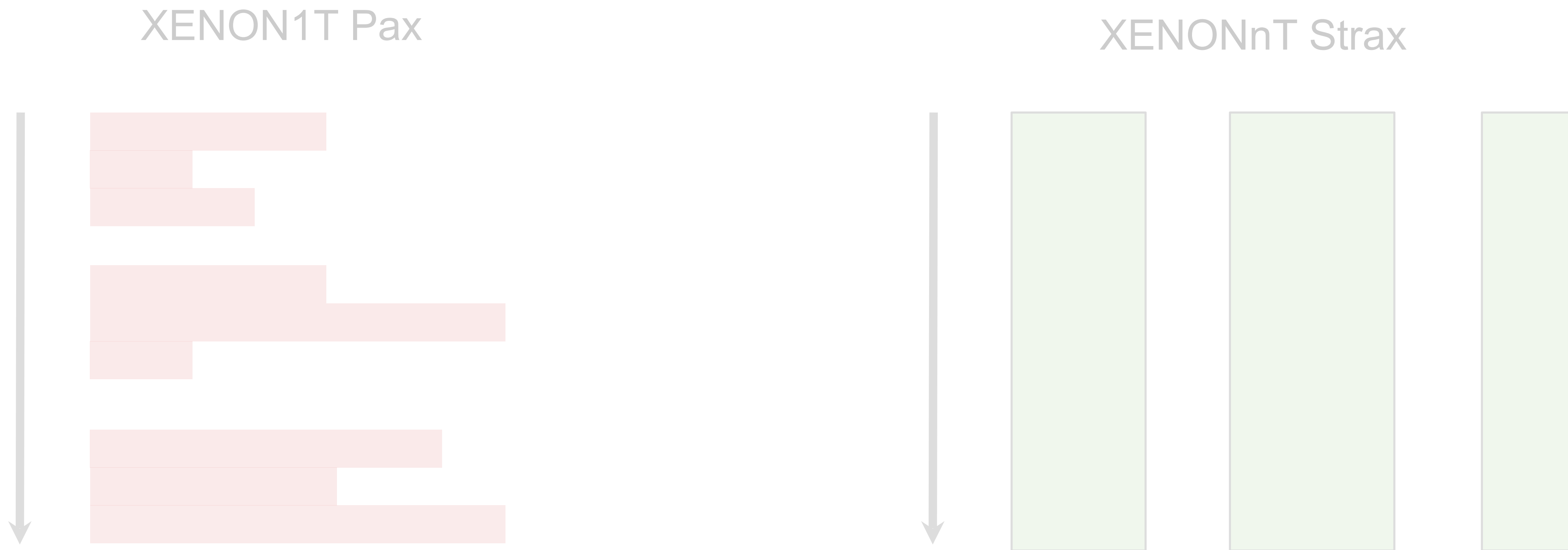
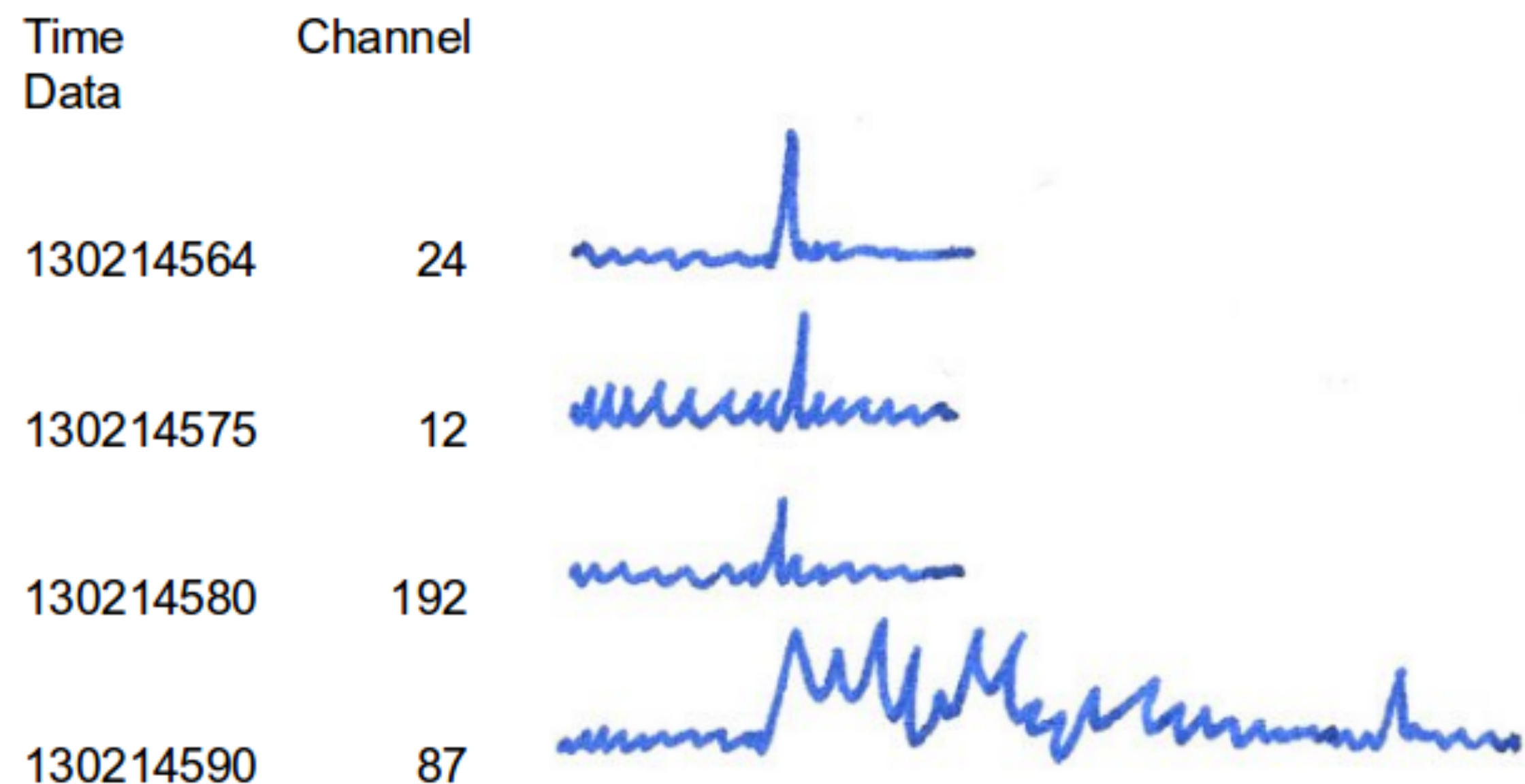

Table 1. Rate of processing a “query sized” payload: filling one histogram of jet p_T for all jets i in a $t\bar{t}$ sample, illustrating the orders of magnitude lost to providing a full framework for heavy event processing (all single-threaded).

0.018 MHz	full framework (CMSSW, single-threaded C++)
0.029 MHz	load all 95 jet branches in ROOT
2.8 MHz	load jet p_T branch (and no others) in ROOT
12 MHz	allocate C++ objects on heap, fill, delete
31 MHz	allocate C++ objects on stack, fill histogram
250 MHz	minimal “for” loop in memory (single-threaded C)

Avoiding variable-length objects

XENON1T / pax: **pulses**



XENONnT / strax: **"records" / "fragments"**

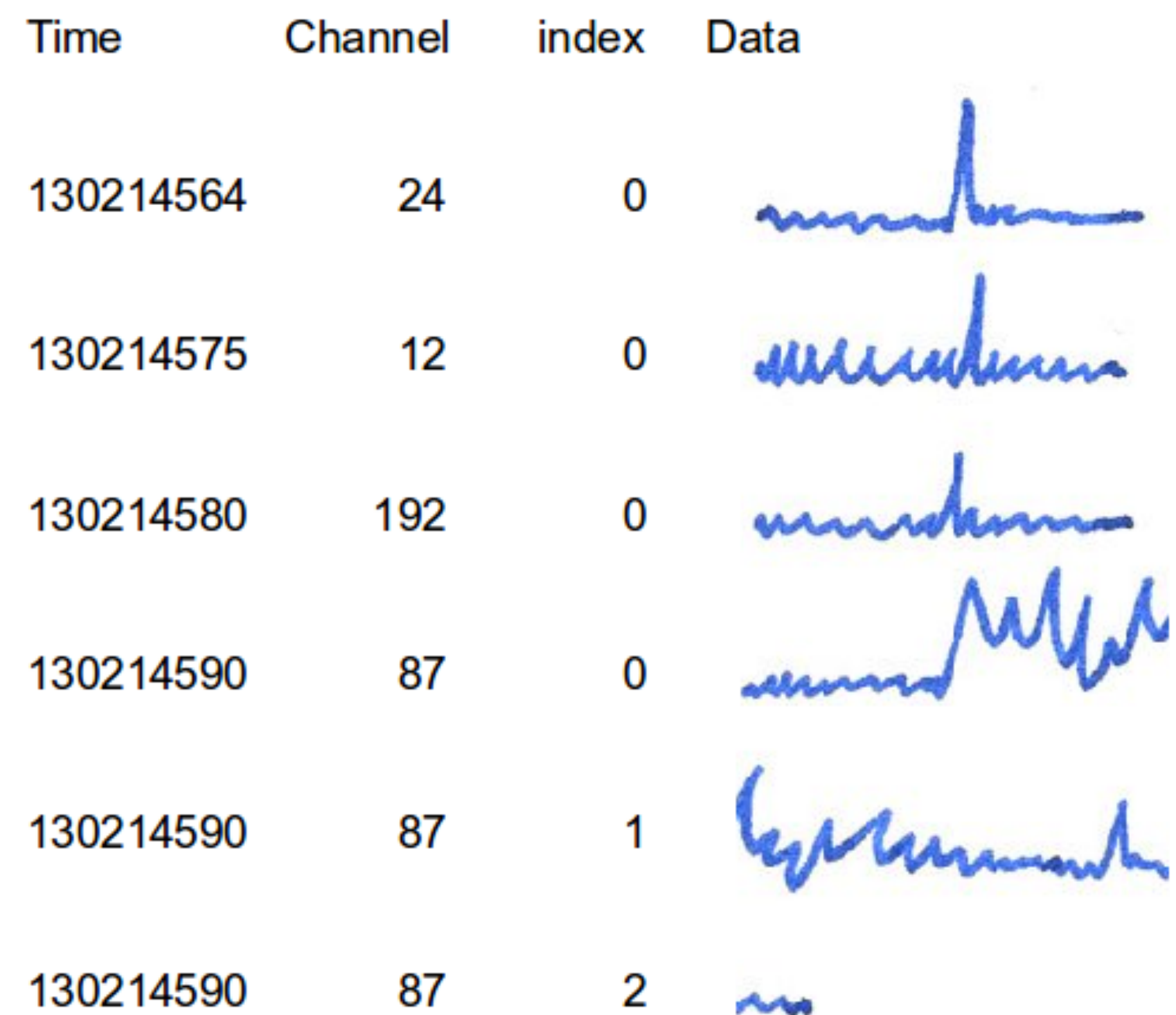

Processing

```
2022-01-20 13:46:25.175169 | INFO | eb_can_process (L718) | running: 2    busy: 0 queue: 0
2022-01-20 13:46:25.178507 | INFO | cleanup_db (L1602) | Checking for bad stuff in database
2022-01-20 13:46:25.688711 | INFO | main_loop (L435) | No work to do, waiting for new runs or retry timers
2022-01-20 13:46:35.701777 | INFO | main_loop (L386) | bootstrax running for 12388 seconds
```

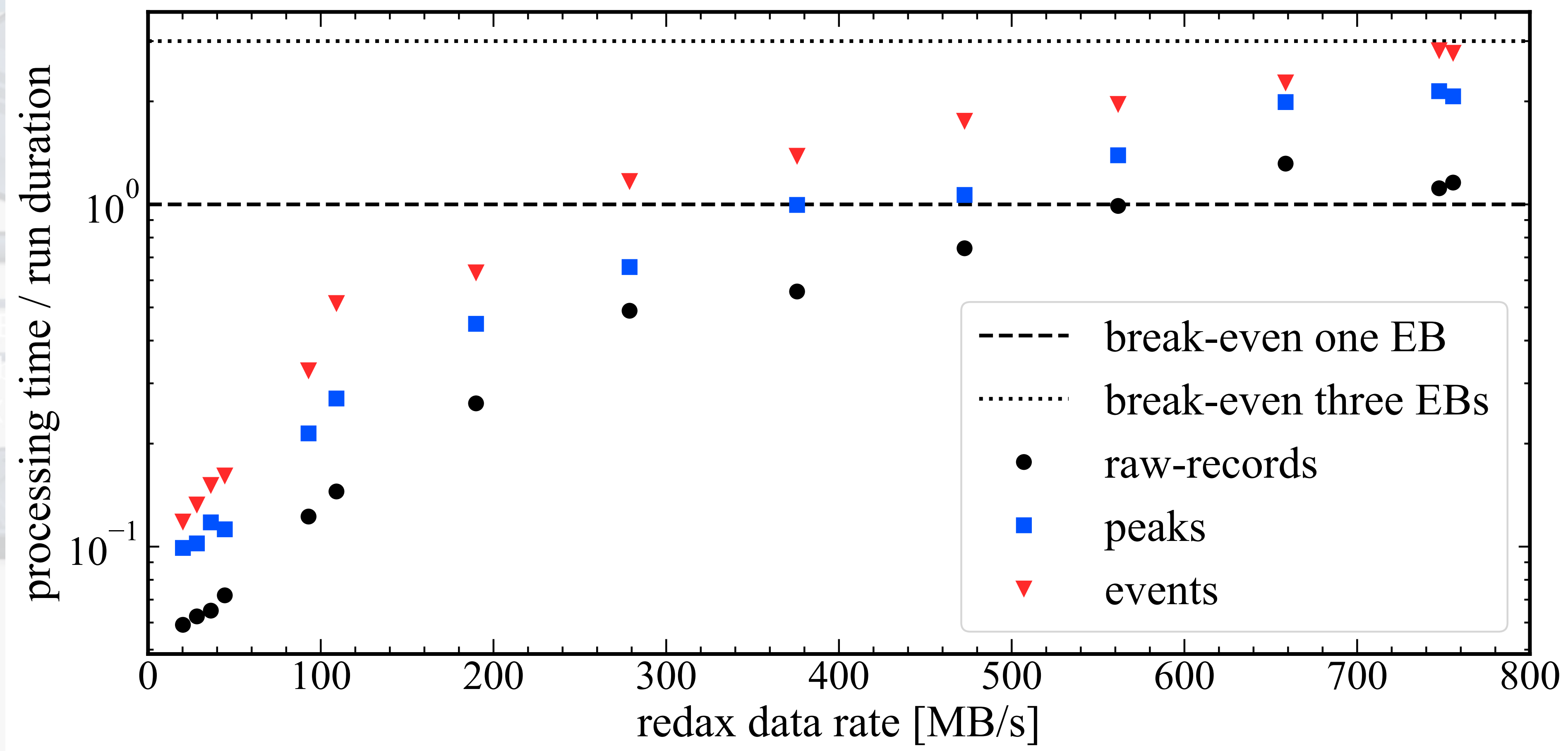
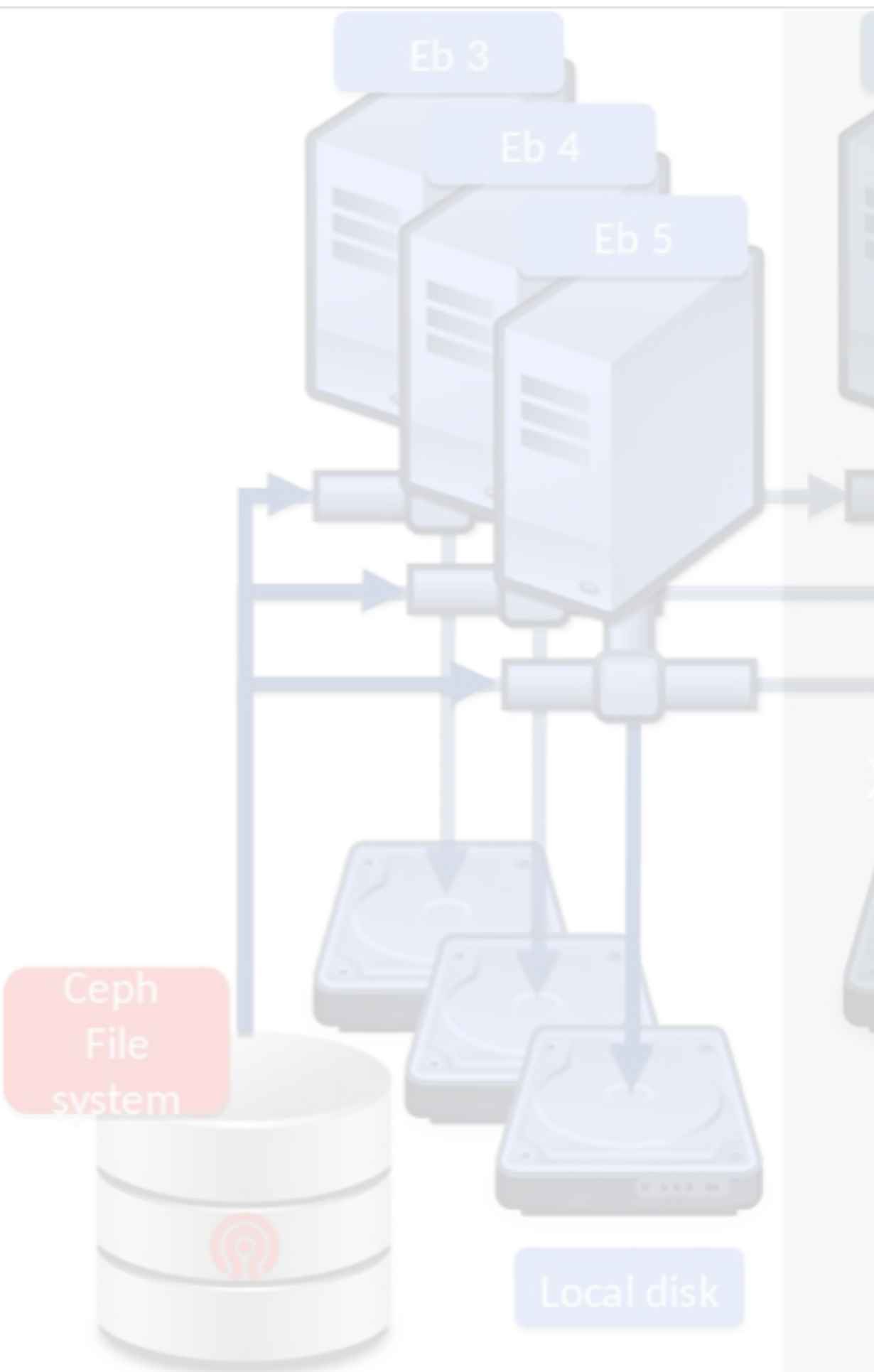

Processing



```
2022-01-20 13:46:25.175169 | INFO | eb_can_process (L718) | running: 2    busy: 0 queue: 0
2022-01-20 13:46:25.178507 | INFO | cleanup_db (L1602) | Checking for bad stuff in database
2022-01-20 13:46:25.688711 | INFO | main_loop (L435) | No work to do, waiting for new runs or retry timers
2022-01-20 13:46:35.701777 | INFO | main_loop (L386) | bootstrax running for 12388 seconds
2022-01-20 13:46:35.702234 | DEBUG | sufficient_diskspace (L857) | Check disk space: 5.2% full
2022-01-20 13:46:35.702371 | INFO | main_loop (L389) | Looking for work
2022-01-20 13:46:35.714508 | INFO | eb_can_process (L718) | running: 2    busy: 0 queue: 0
2022-01-20 13:46:35.717822 | INFO | main_loop (L435) | No work to do, waiting for new runs or retry timers
2022-01-20 13:46:45.731050 | INFO | main_loop (L386) | bootstrax running for 12398 seconds
2022-01-20 13:46:45.731249 | DEBUG | sufficient_diskspace (L857) | Check disk space: 5.2% full
2022-01-20 13:46:45.731361 | INFO | main_loop (L389) | Looking for work
```

strax

Streaming analysis for xenon experiments

DOI [10.5281/zenodo.1340632](https://doi.org/10.5281/zenodo.1340632) docs **passing** coverage **86%** tests **passing** codefactor **A**

pypi **v1.1.5** python **3.6 | 3.7 | 3.8 | 3.9** downloads **3.4k/month** gitter **join chat**



Languages

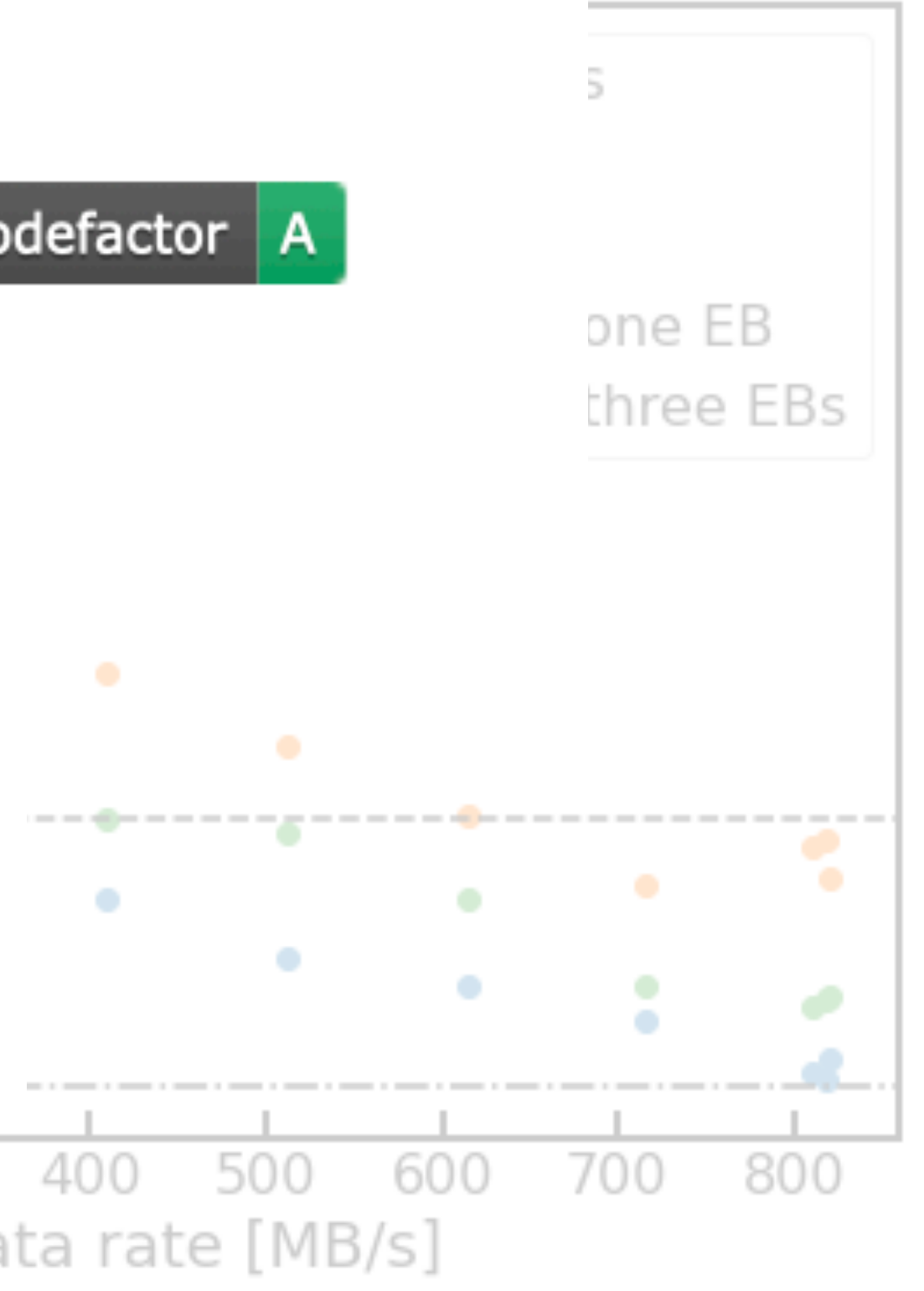

Monitoring

⚠ There are unacknowledged errors. Please go to the log page to close them

Status History Time: Resolution: Variable:

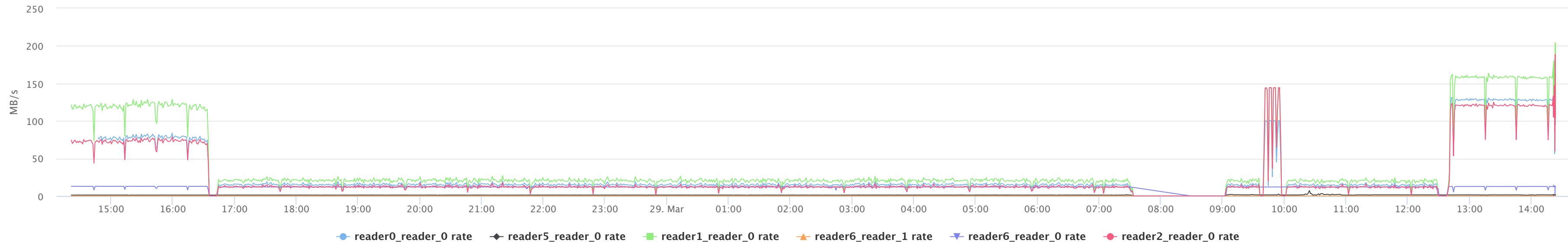

reader0 is Running 139.02 MB/s Checked in 0 seconds ago	reader1 is Running 162.66 MB/s Checked in 0 seconds ago	reader2 is Running 113.54 MB/s Checked in 0 seconds ago	Muon Veto is Running 1.45 MB/s Checked in 0 seconds ago
Neutron Veto a is Running 12.70 MB/s Checked in 0 seconds ago	Neutron Veto b is Idle 0.00 MB/s Checked in 0 seconds ago	TPC controller is Running V2718: 🟢🔴🟢🟢 (0Hz) Checked in 0 seconds ago	MV controller is Running V2718: 🟢🔴🟢🔴 (0Hz) Checked in 0 seconds ago
NV controller is Running V2718: 🟢🔴🟢🔴 (0Hz) Checked in 0 seconds ago	Dispatcher is online Checked in 0 seconds ago	eb0 is processing 051425 on 6 cores to event_basics,online_peak_monitor,online_monitor_nv,individ Checked in 1 seconds ago	eb1 is napping Checked in 8 seconds ago
eb2 is hosting SKYNET Checked in 3 seconds ago	eb3 is processing 051427 on 9 cores to event_basics,online_peak_monitor,online_monitor_nv,individ Checked in 10 seconds ago	eb4 is processing 051428 on 24 cores to online_monitor_mv Checked in 2 seconds ago	eb5 is processing 051426 on 9 cores to event_basics,online_peak_monitor,online_monitor_nv,individ Checked in 10 seconds ago

ceph HEALTH_OK Occupancy: 5.76/10.23TB

OSD 0 Rd: 3 (4.91 MB) Wrt: 14 (30.00 MB/s)	OSD 1 Rd: 2 (5.12 MB) Wrt: 10 (14.00 MB/s)
OSD 2 Rd: 3 (6.35 MB) Wrt: 8 (22.00 MB/s)	OSD 3 Rd: 2 (4.95 MB) Wrt: 12 (23.00 MB/s)
OSD 4 Rd: 2 (3.49 MB) Wrt: 58 (20.00 MB/s)	OSD 5 Rd: 4 (6.49 MB) Wrt: 8 (24.00 MB/s)
OSD 6 Rd: 3 (6.25 MB) Wrt: 16 (37.00 MB/s)	OSD 7 Rd: 3 (3.31 MB) Wrt: 9 (27.00 MB/s)
OSD 8 Rd: 0 (2.18 MB) Wrt: 14 (33.00 MB/s)	OSD 9 Rd: 3 (5.67 MB) Wrt: 13 (26.00 MB/s)
OSD 10 Rd: 3 (5.87 MB) Wrt: 13 (25.00 MB/s)	OSD 11 Rd: 2 (3.12 MB) Wrt: 16 (31.00 MB/s)

Recent Dispatcher Commands

2023-03-29 14:16 UTC: start for detector tpc from lprincipe(2/2)
2023-03-29 14:16 UTC: start for detector tpc from lprincipe(4/4)
2023-03-29 14:16 UTC: arm for detector tpc from lprincipe(6/6)
2023-03-29 14:16 UTC: stop for detector tpc from lprincipe(4/4)
2023-03-29 14:16 UTC: stop for detector tpc from lprincipe(2/2)
2023-03-29 14:04 UTC: start for detector muon_veto from biondi(1/1)
2023-03-29 14:04 UTC: start for detector muon_veto from biondi(1/1)
2023-03-29 14:04 UTC: arm for detector muon_veto from biondi(2/2)
2023-03-29 14:04 UTC: stop for detector muon_veto from biondi(1/1)
2023-03-29 14:04 UTC: stop for detector muon_veto from biondi(1/1)

⚠ There are unacknowledged errors. Please go to the log page to close them

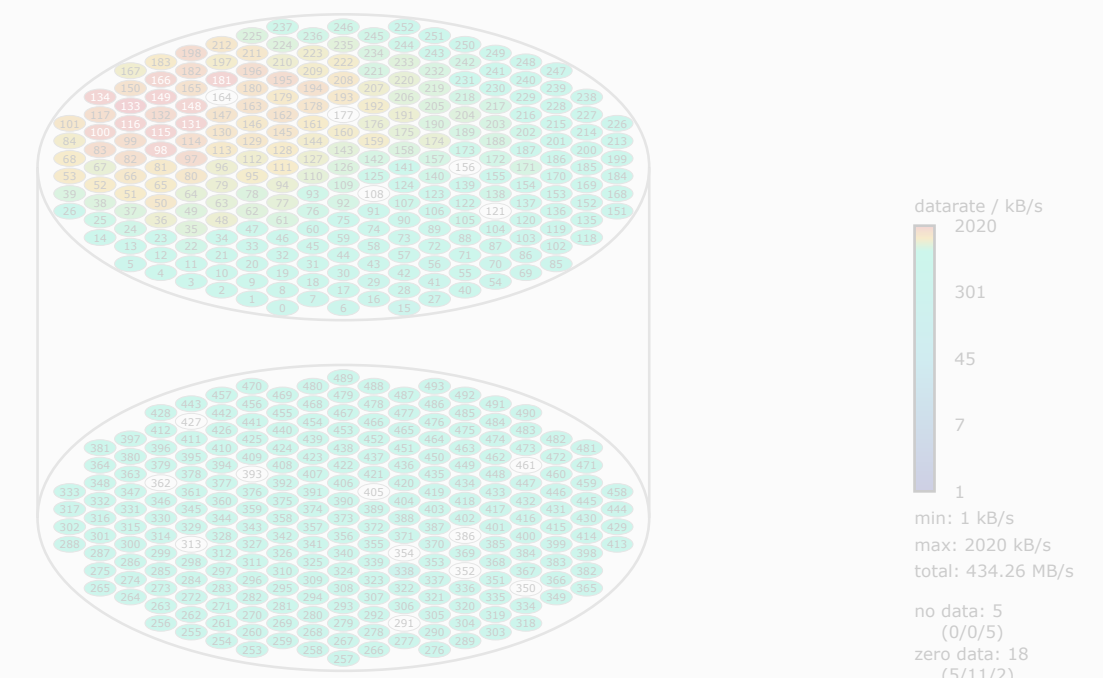

no data: 5 (0/0/5)
zero data: 18 (5/11/2)
reader0_reader_0: 2023-03-29T14:14:19.001Z (UTC)
reader1_reader_0: 2023-03-29T14:14:19.002Z (UTC)
reader2_reader_0: 2023-03-29T14:14:19.001Z (UTC)

XENON DAQ

NT

Overview

Control

Status

Hosts

Config

Runs

Monitor

View

PMT Layout:

Live data:

Monitoring

- ☰
- XENON DAQ
- NT
- Overview
- Control
- Status
- Hosts
- Config
- Runs
- Monitor
- ☞ Sign Out

⚠ There are unacknowledged errors. Please go to the log page to close them

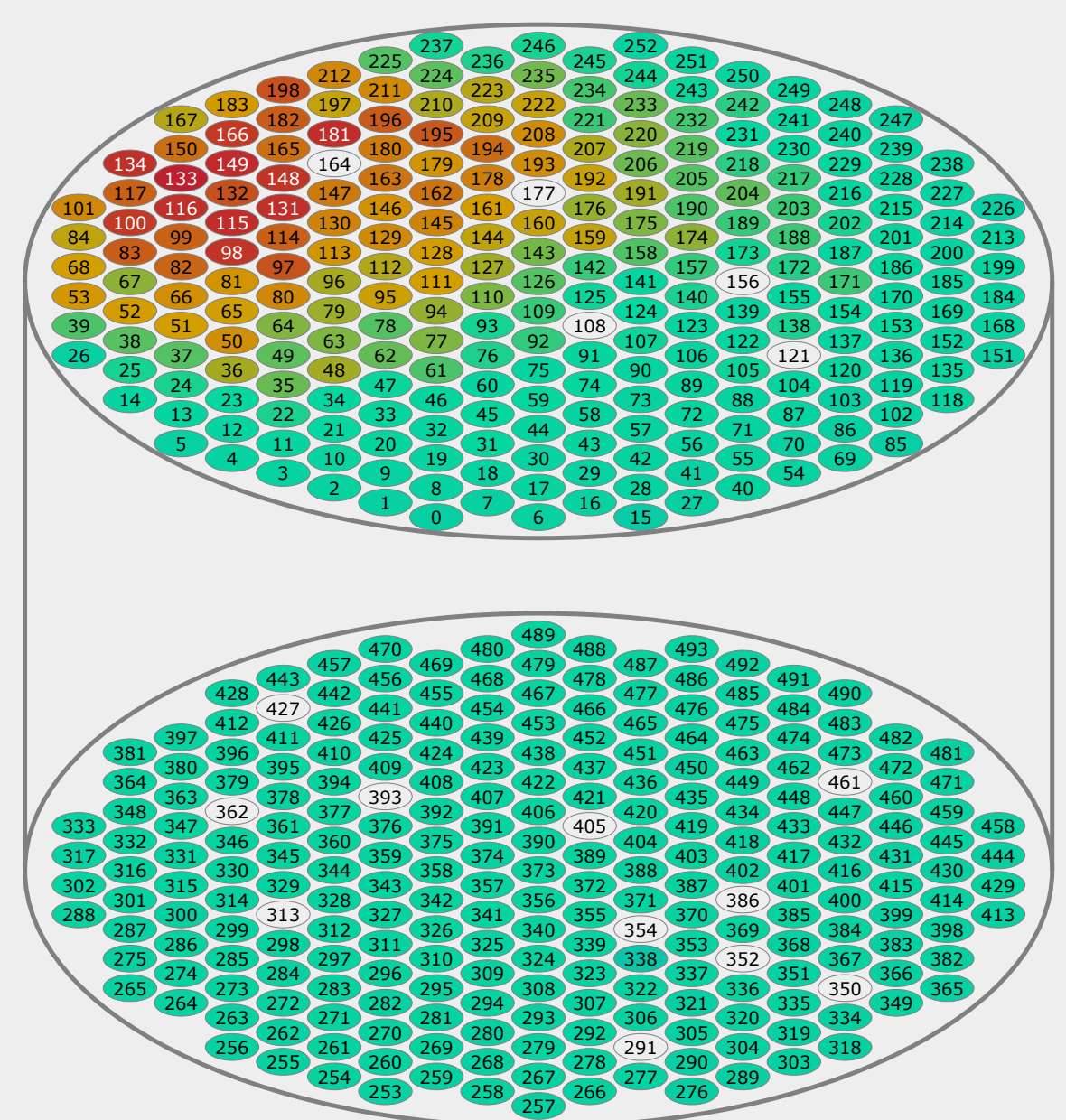

datarate / kB/s
2020
301
45
7
1
min: 1 kB/s
max: 2020 kB/s
total: 434.26 MB/s
no data: 5 (0/0/5)
zero data: 18 (5/11/2)

reader0_reader_0: 2023-03-29T14:14:19.001Z (UTC)
reader1_reader_0: 2023-03-29T14:14:19.002Z (UTC)
reader2_reader_0: 2023-03-29T14:14:19.001Z (UTC)

View

PMT Layout:

Live data:

Datarate scale:

Ignore PMTs:

Colour scale:

Fading:

PMT Labels:

Time shown

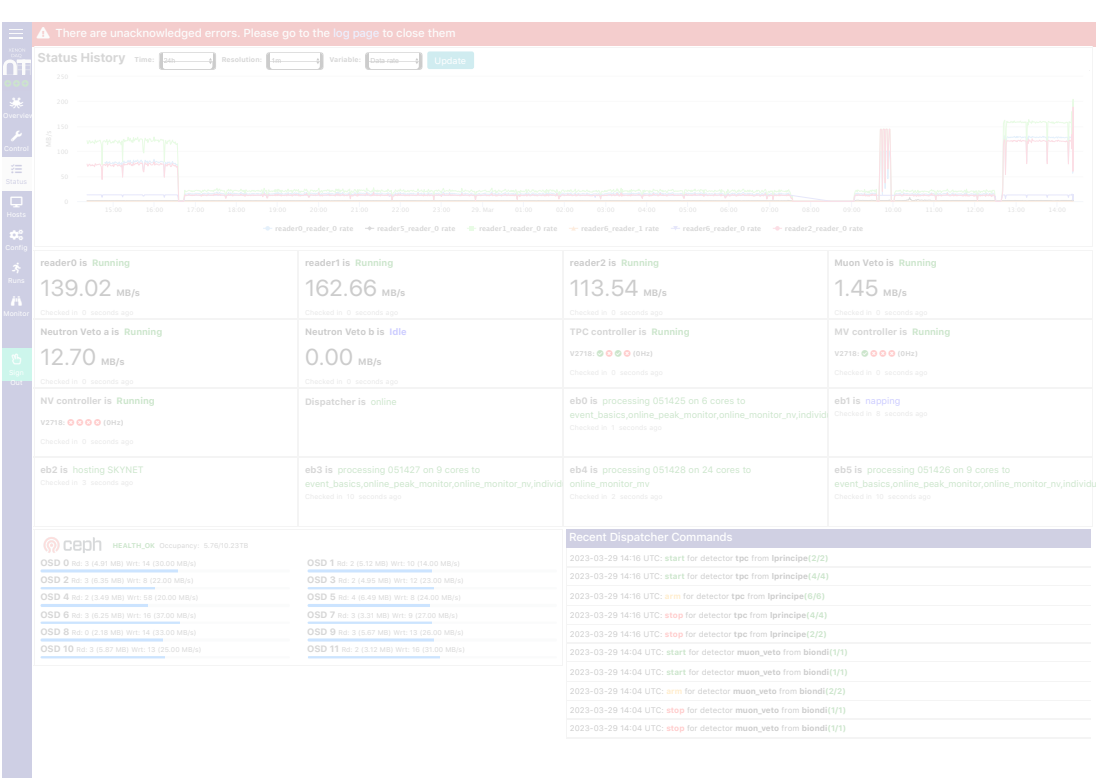

Monitoring

Single Electron in last 6.2 hours

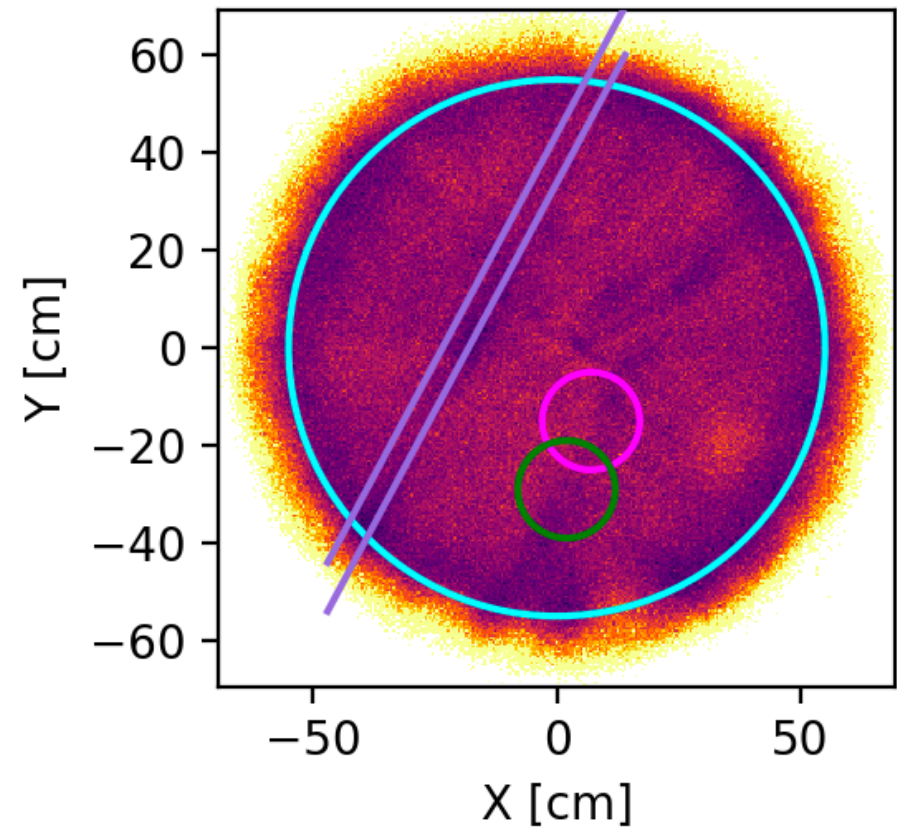

Single Electron in last run 038271

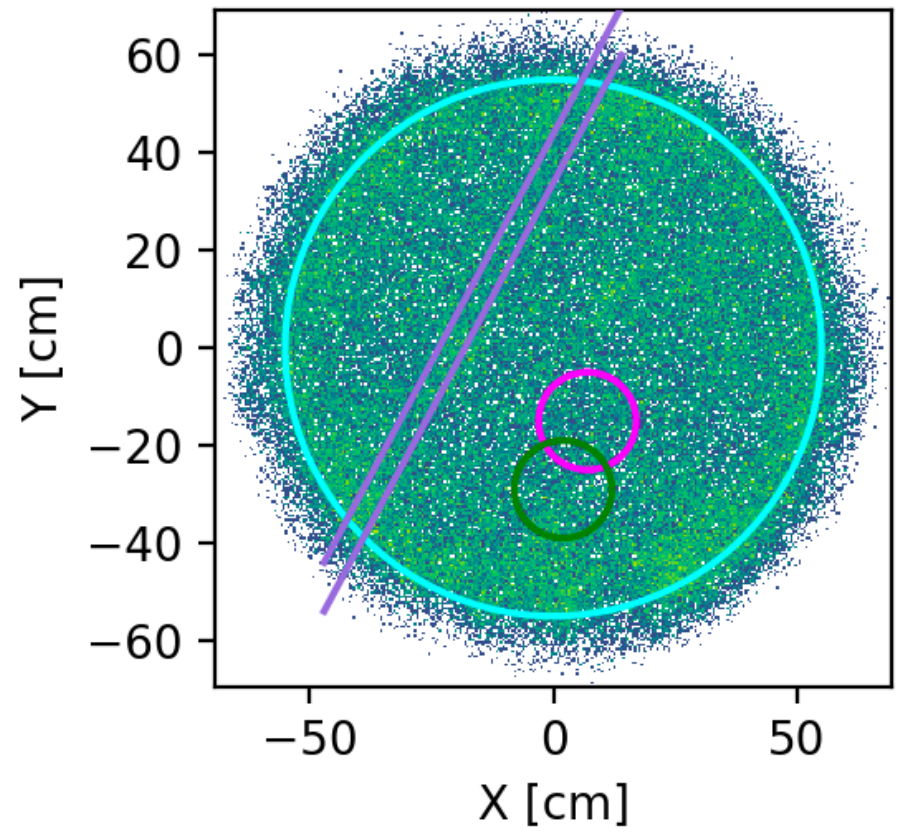

Area-width distribution in last run

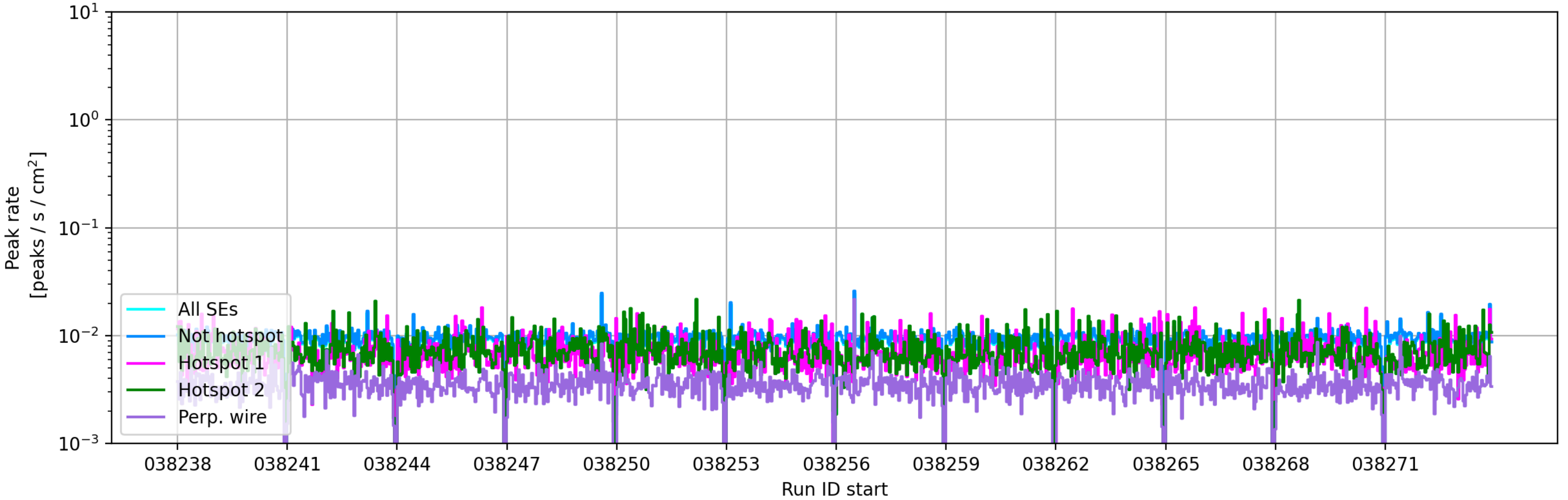
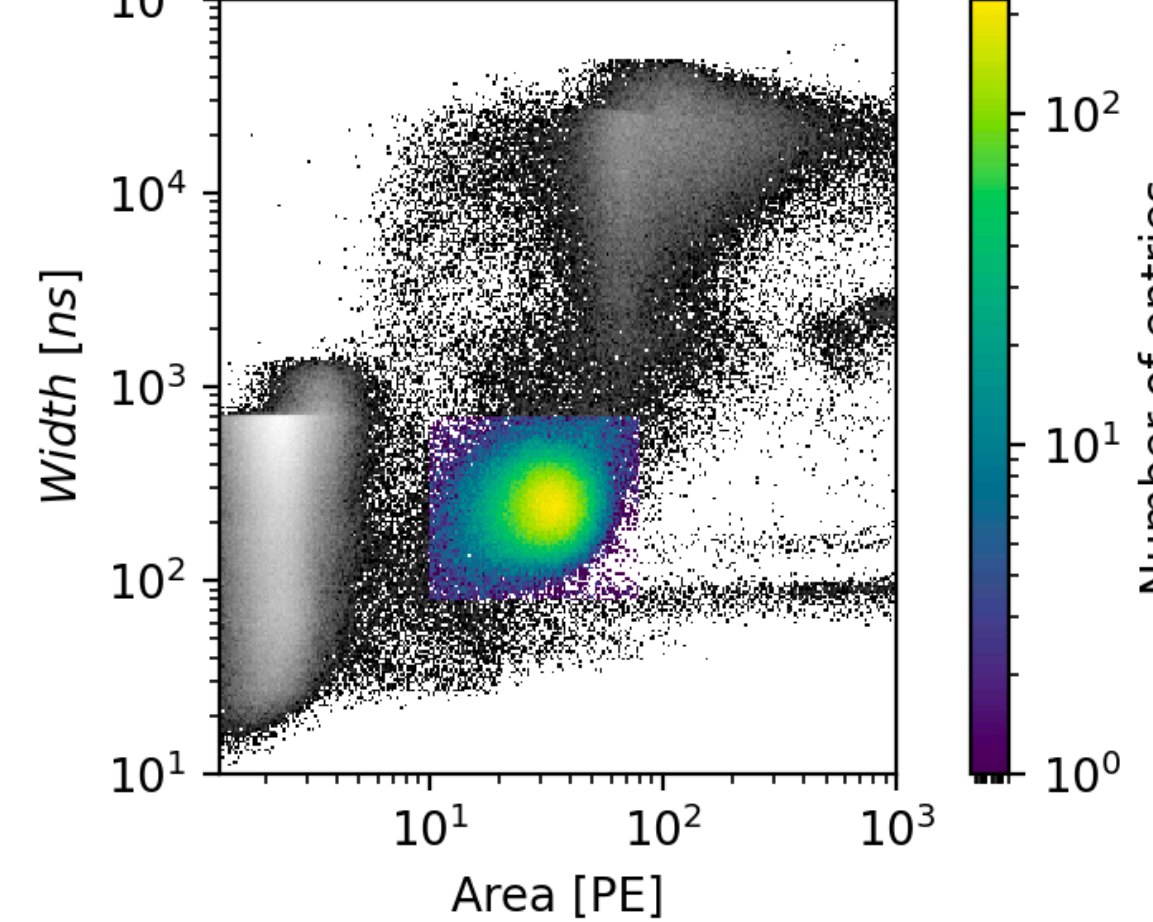

```
NT Hypervisor is restarting reader0_reader_0
@daq
Hypervisor is restarting reader1_reader_0
@daq
Hypervisor is restarting reader2_reader_0
@daq
47
✓ 1
```

Monitoring

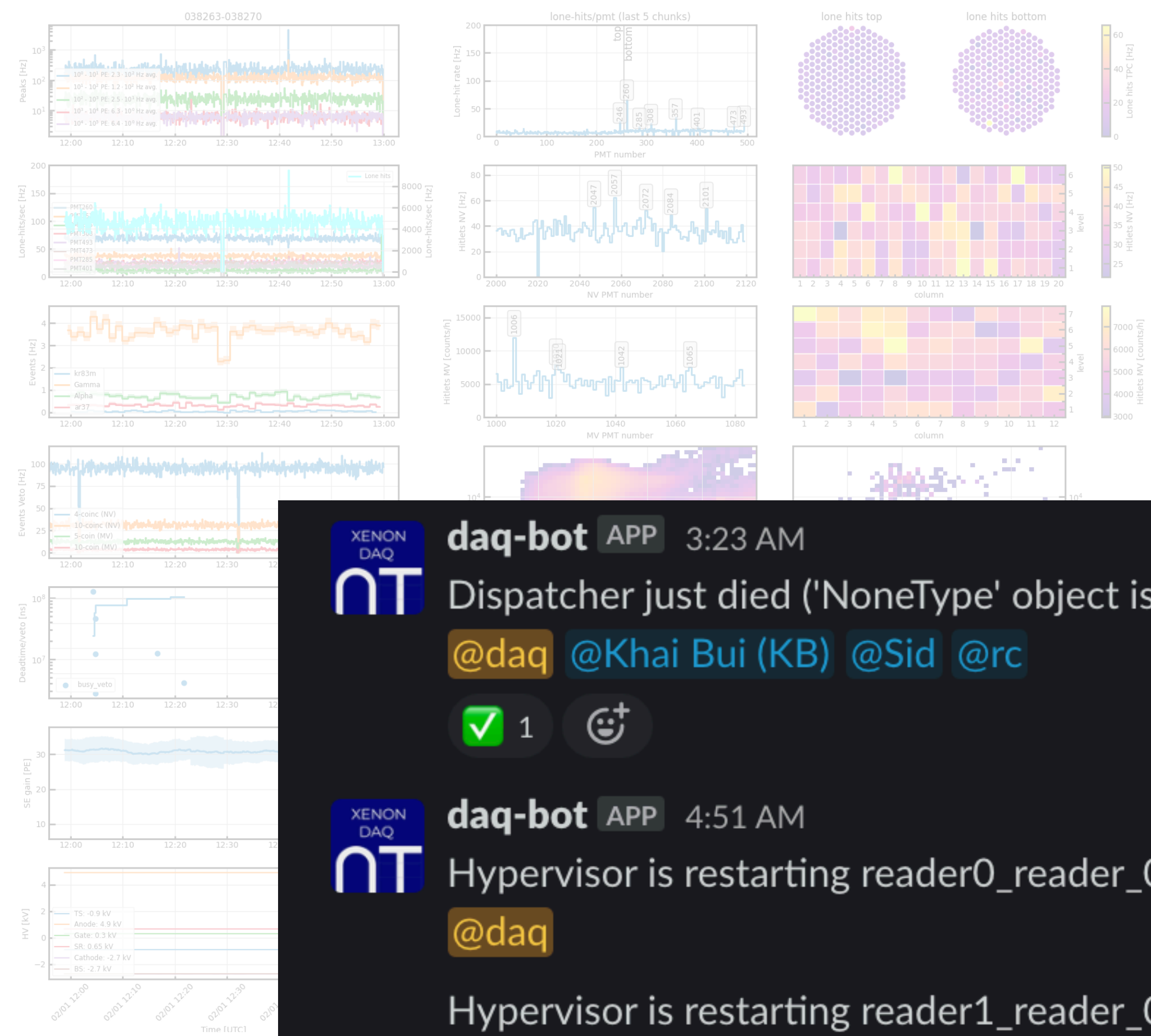

Single Electron in last 6.2 hours

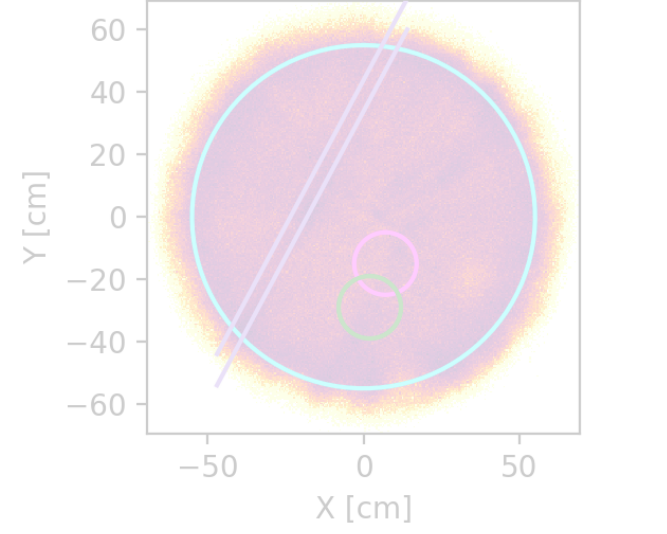

Single Electron in last run 038271

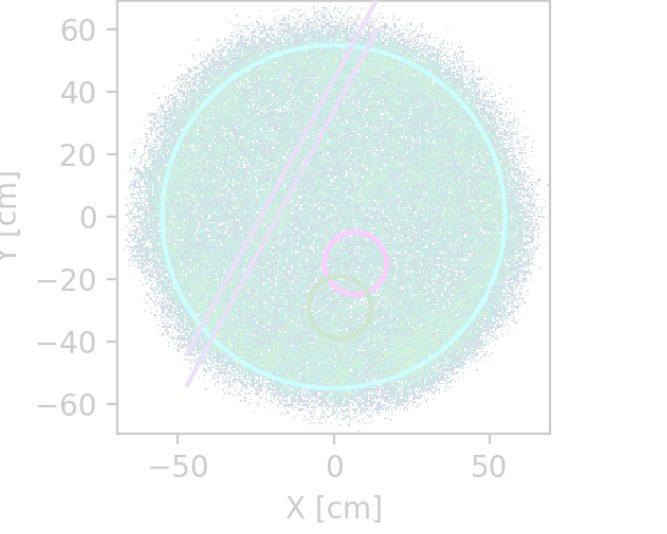

Area-width distribution in last run

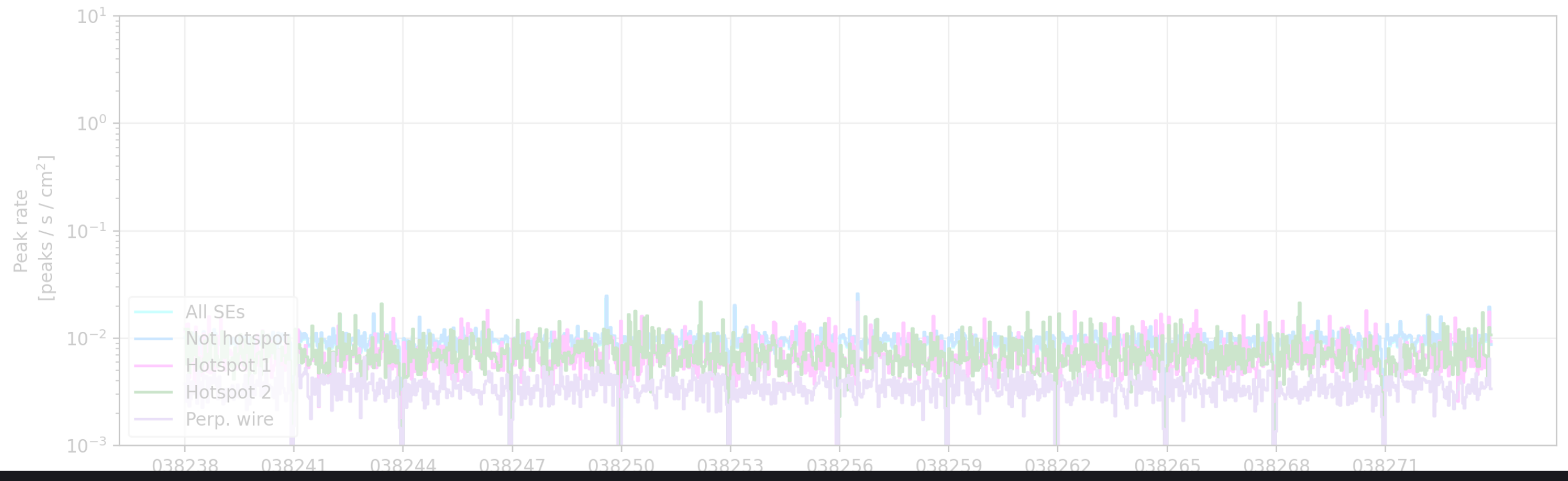
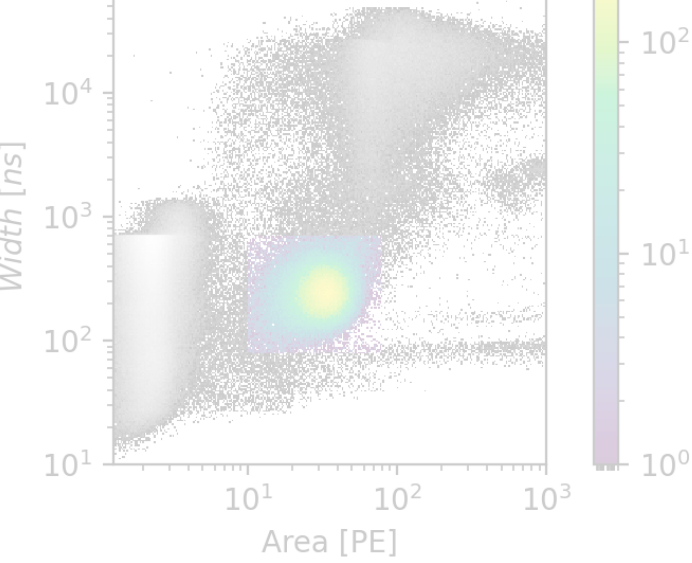

XENON DAQ **NT** **daq-bot** APP 3:23 AM
Dispatcher just died ('NoneType' object is not subscriptable), this is very bad. We're going to try a reboot but please alert the DAQ-group.
[@daq](#) [@Khai Bui \(KB\)](#) [@Sid](#) [@rc](#)
✓ 1 🧡

XENON DAQ **NT** **daq-bot** APP 4:51 AM
Hypervisor is restarting reader0_reader_0
[@daq](#)

Hypervisor is restarting reader1_reader_0
[@daq](#)

Hypervisor is restarting reader2_reader_0
[@daq](#)
✓ 1 🧡

XENONnT's DAQ Wishlist:

- ✓ Acquire data from both low (<10 keV) and high (>2 MeV) energy signals
- ✓ Handle high data rates (calibration)
- ✓ Low dead time
- ✓ Low threshold
- ✓ Real time processing
- ✓ Data available as fast as possible
- ✓ Live monitoring
- ✓ No/low expert intervention required

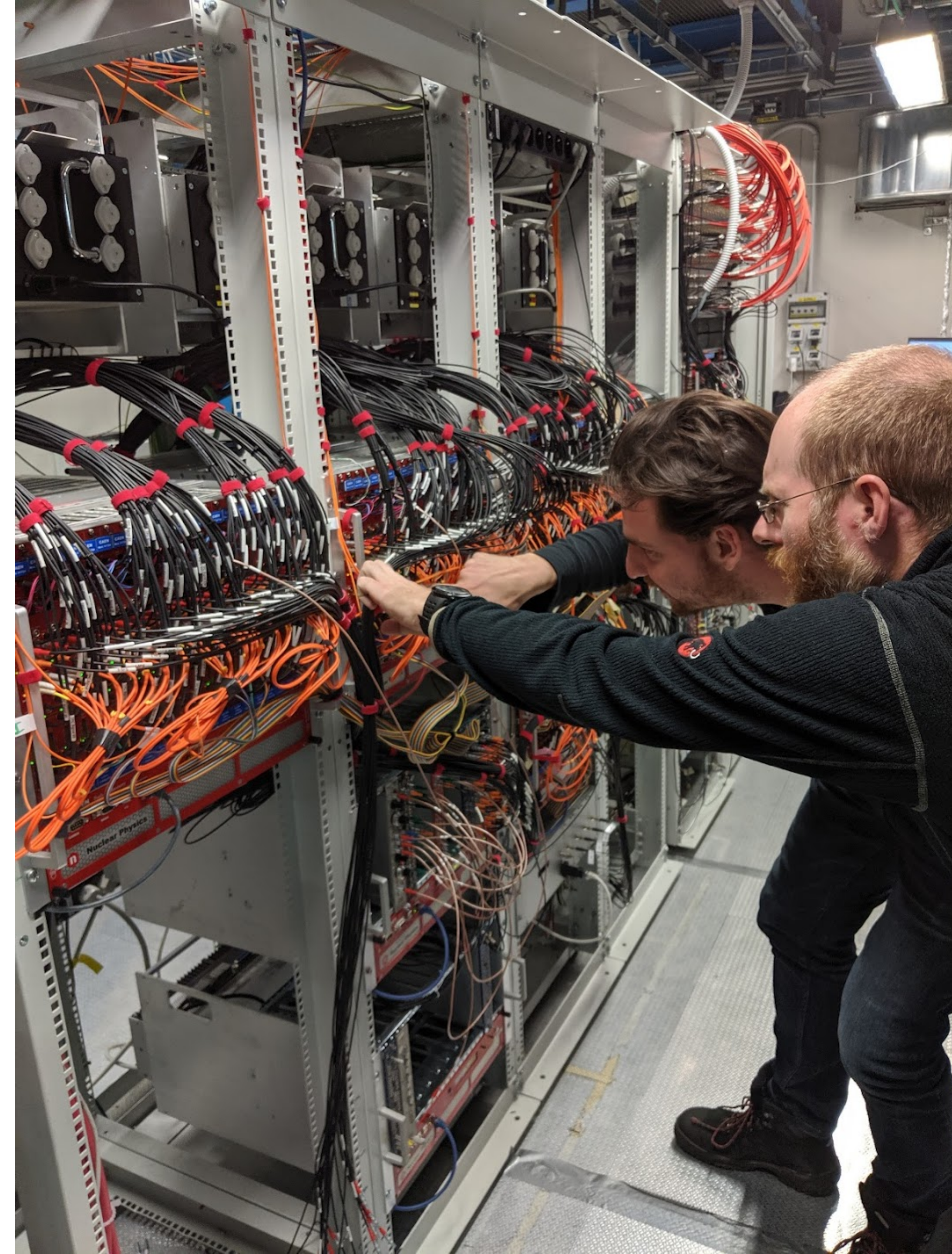

- XENONnT's DAQ can read out and process in real time data rates up to $\sim 80x$ higher than the maximum expected TPC rate without triggering

- Readout: redax
<https://github.com/AxFoundation/redax>
- Processor: strax
<https://github.com/AxFoundation/strax>
<https://github.com/XENONnT/straxen>

Made possible by the (former)
XENON DAQ group:

- Maricke Flierman
- Carlo Fuselli
- Robin Glade-Beucke
- Andrea Molinario
- Alessandro Razeto
- Daniel Wenz
- (Alexey Elykov)
- (Peter Gaemers)
- (Darryl Masson)
- (Jelle Aalbers)
- (Dan Coderre)
- (Chris Tunnell)
- (Joran Angevaare)
- (Patrick Decowski)
- (Valerio D'Andrea)
- (Marc Schumann)

