



NATIONAL
ACCELERATOR
LABORATORY



B Anomalies circa '23 : A Theorist's Perspective

MAURO VALLI



Stony Brook
University

YITP Stony Brook / INFN Rome



SIMONS
FOUNDATION

May 16, 2023



The Standard Model

CHANGES I WOULD MAKE TO THE STANDARD MODEL

CONSISTENT QUARK NAMES
(USE "STRANGE" AND "CHARM" FOR BOSONS)

U UP	L LEFT	t TOP	g GLUON	V VIN DIESEL	WITH ALL RESPECT TO PETER H, THE HIGGS BOSON NEEDS A FLASHIER NAME
d DOWN	R RIGHT	b BOTTOM	γ PHOTON	G GRAVITON	LET'S JUST INCLUDE IT, IT'S PROBABLY FINE
e ELECTRON	M MUON	τ NO ONE NEEDS TAU LEPTONS	S STRANGE BOSON	M MAGIC	DECOY PARTICLE FOR PEOPLE MAKING NONSENSE CLAIMS ABOUT "QUANTUM" PHILOSOPHY STUFF
ν_e ELECTRON NEUTRINO	ν_μ TOO MANY NEUTRINOS	D DARK MATTER	C CHARM BOSON	COOL BUGS	VERY SMALL BUGS ARE FUNDAMENTAL PARTICLES NOW

Fix NEUTRINO SYMBOL SO I STOP MIXING UP ν AND V

WE FOUND IT!

Bugs are spin 1/2 particles, unless it's particularly windy.

- $SU(3)_c \times SU(2)_L \times U(1)_Y$
+ Poincaré symmetries
- w/ Matter field content:

$$H + Q_i, L_i, u_i, d_i, e_i$$

$i=1,2,3$ FLAVOR

IT LOOKS INCOMPLETE ...

The Standard Model

THE SM
FLAVOR
PUZZLE

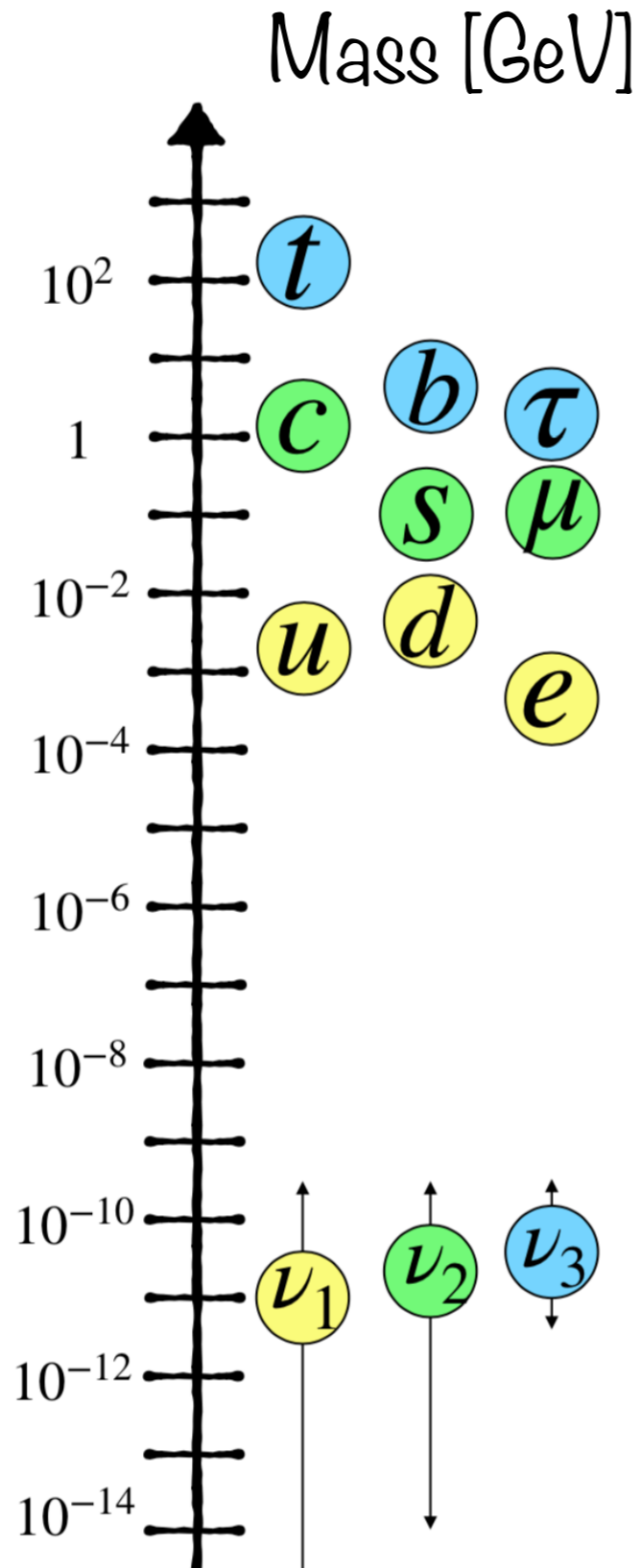

$$V_{\text{CKM}} = \begin{pmatrix} V_{ud} & V_{us} & V_{ub} \\ V_{cd} & V_{cs} & V_{cb} \\ V_{td} & V_{ts} & V_{tb} \end{pmatrix} \begin{matrix} u \\ c \\ t \\ d \\ s \\ b \end{matrix}$$

Why?

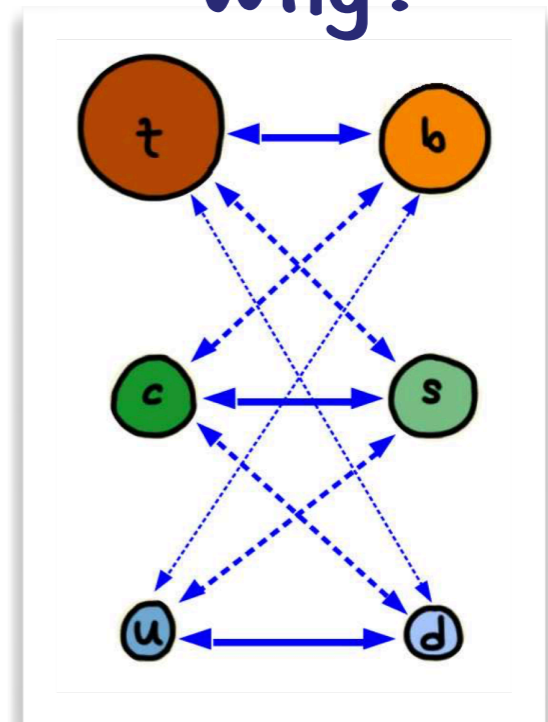

The Standard Model

Lagrangian:

$$\mathcal{L}(x) = \sum c_{\mathcal{O}} \Lambda_{\mathcal{O}}^{4-\dim \mathcal{O}} \mathcal{O}(x)$$

Parameter (red arrow pointing to $c_{\mathcal{O}}$)

Cutoff scale (blue arrow pointing to $\Lambda_{\mathcal{O}}$)

Local operator - a monomial in fields and derivatives (black arrow pointing to $\mathcal{O}(x)$)

$$\text{Physical effects} \sim \left(\frac{E}{\Lambda_{\mathcal{O}}} \right)^{\dim \mathcal{O} - 4}$$

credit to A.Greljo
@ LHC Forum '23

The Standard Model is an Effective Field Theory (EFT).

CHEF

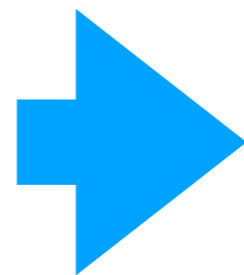

Mass Gap
 $\Lambda_{\mathcal{O}} \gtrsim \Lambda_{EW}$

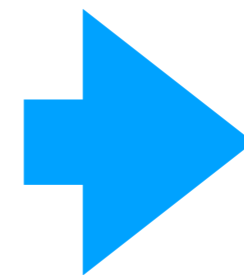

PRECISION TESTS!

Precision Tests: Flavor

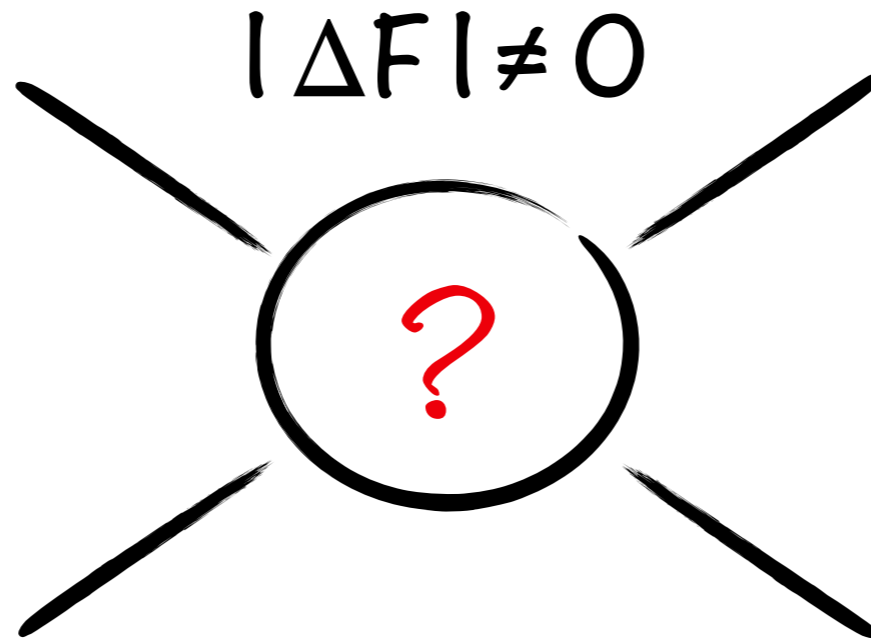
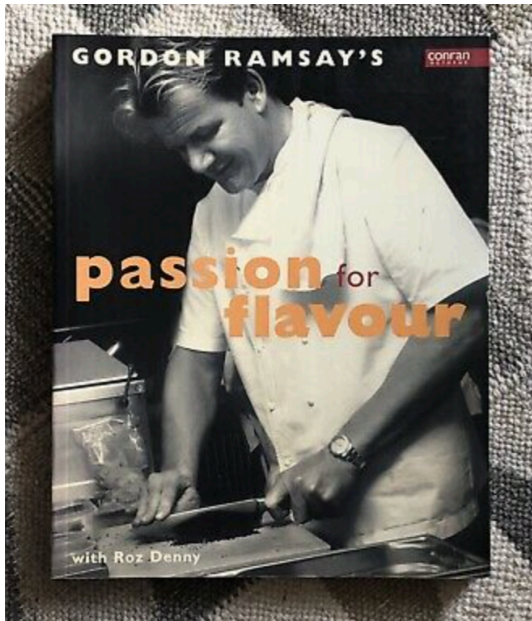

Look @
processes w/
units of
flavor violation

Historically, it led to “New Physics” (NP) !

*E.g., prediction
of charm quark:*

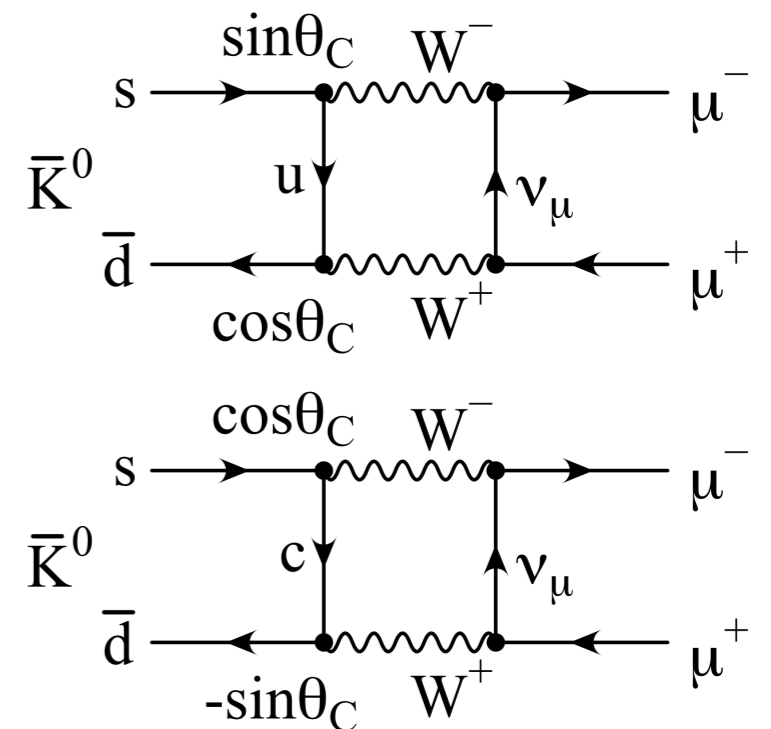
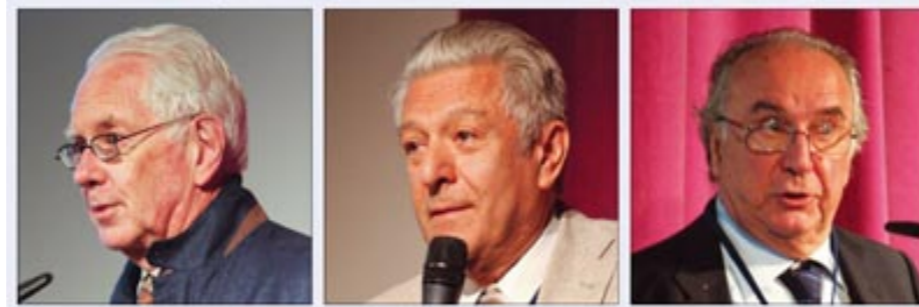

Flavor Precision:

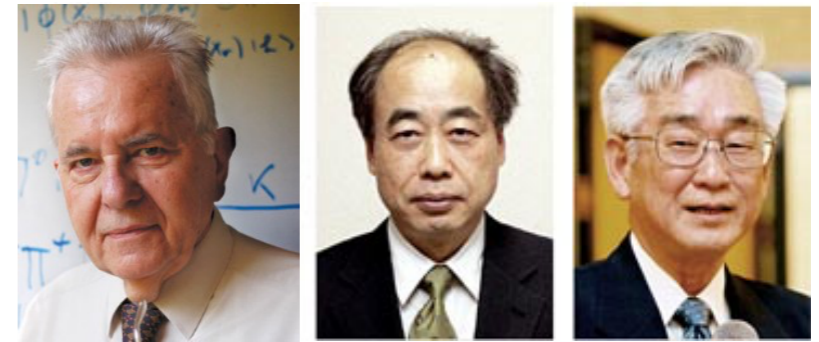

- Flavor violation in SM in charged weak-current $\longleftrightarrow V_{\text{CKM}}$
→ Flavor Changing Neutral Currents (FCNCs) **ONLY** @ one loop
- CKM matrix described by 4 params (3 angles and a ~~CP~~ phase)

$$V_{\text{CKM}} = \begin{pmatrix} 1 - \lambda^2/2 & \lambda & A\lambda^3(\bar{\rho} - i\bar{\eta}) \\ -\lambda & 1 - \lambda^2/2 & A\lambda^2 \\ A\lambda^3(1 - \bar{\rho} - i\bar{\eta}) & -A\lambda^2 & 1 \end{pmatrix} + \mathcal{O}(\lambda^4)$$

$(\bar{\rho}, \bar{\eta})$ apex of

$$V_{ub}^* V_{ud} + V_{cb}^* V_{cd} + V_{tb}^* V_{td} = 0$$

Unitarity Triangle (UT)

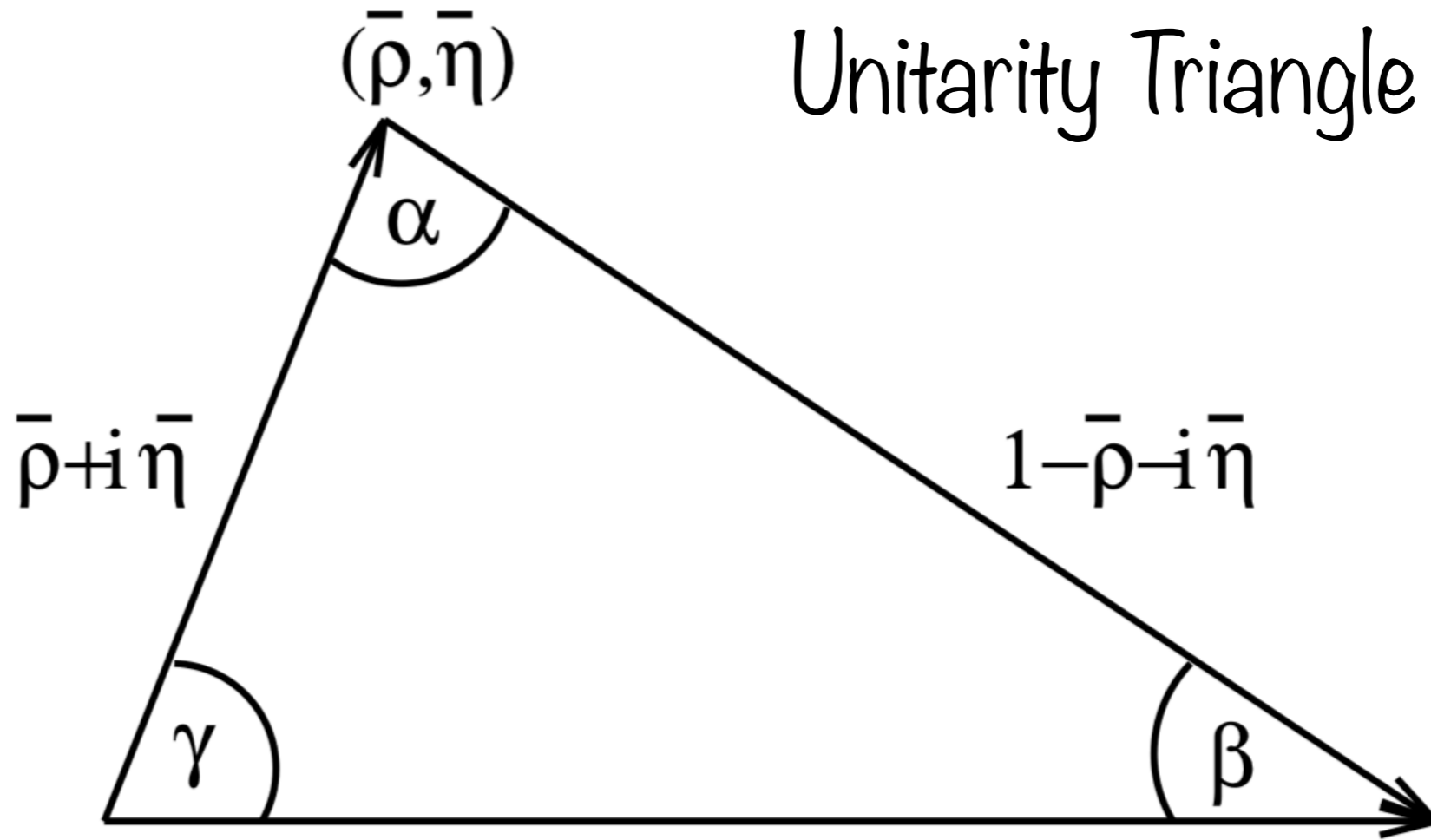

$$-\frac{V_{ud}V_{ub}^*}{V_{cd}V_{cb}^*} - \frac{V_{td}V_{tb}^*}{V_{cd}V_{cb}^*} = R_b e^{i\gamma} + R_t e^{-i\beta} = 1 \simeq (\bar{\rho} + i\bar{\eta}) + (1 - \bar{\rho} - i\bar{\eta})$$



www.utfit.org



M. Bona, M. Ciuchini, D. Derkach, F. Ferrari, E. Franco, V. Lubicz, G. Martinelli, M. Pierini, L. Silvestrini, C. Tarantino, V. Vagnoni, M. Valli, and L. Vittorio

— EXP
— TH



LINCEI CELEBRATIVE ESSAYS

New **UTfit** analysis of the unitarity triangle in the Cabibbo–Kobayashi–Maskawa scheme

arXiv: **2212.03894**



Bayes aficionados

$$\mathcal{P}(\bar{\rho}, \bar{\eta}, \vec{p} \mid \vec{\mathcal{O}}) \sim \mathcal{P}(\vec{\mathcal{O}} \mid \bar{\rho}, \bar{\eta}, \vec{p}) \times \mathcal{P}_0(\bar{\rho}, \bar{\eta}, \vec{p})$$

posterior \sim likelihood \times prior

see, e.g., [arXiv:hep-ph/0012308](https://arxiv.org/abs/hep-ph/0012308)

- $\vec{\mathcal{O}} = \{\epsilon_K, \Delta m_{d,s}, \dots\}$

Observables \longleftrightarrow constraints in the fit

- $\vec{p} = \{f_{K,B}, B_{K,B}, \dots\}$

Parameters we can marginalize over

- $(\bar{\rho}, \bar{\eta}) \longleftrightarrow$ CKM pair we wish to infer

UT: How it really works ...

L.Silvestrini @
Les Houches

$\alpha (B \rightarrow \pi\pi, \rho\rho)$

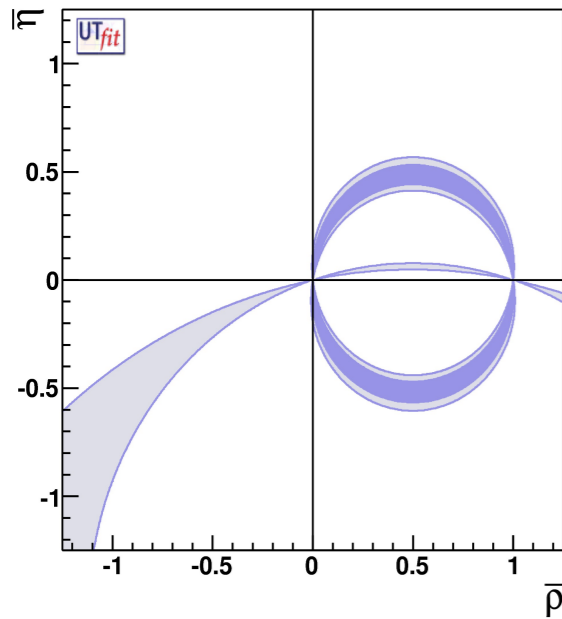

$\beta (B \rightarrow J/\psi K^{(*)})$

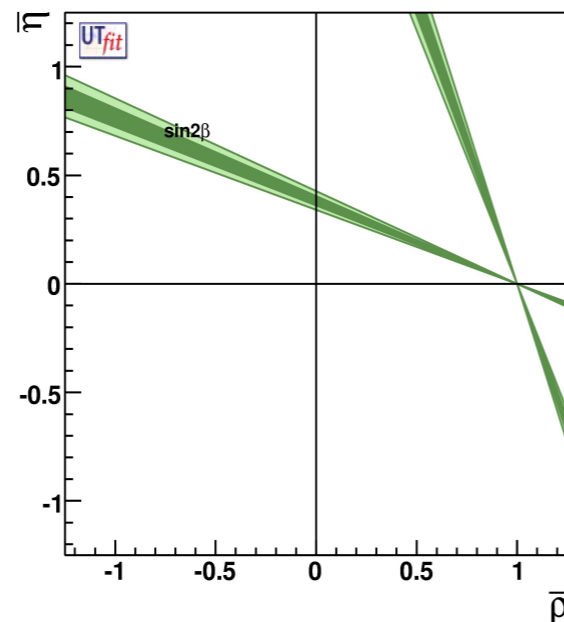

$\gamma (B \rightarrow D^{(*)} K)$

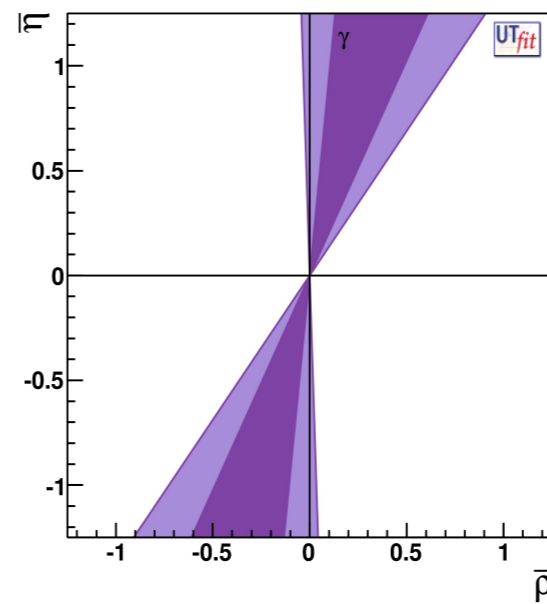

$\text{BR}(B \rightarrow \tau\nu)$

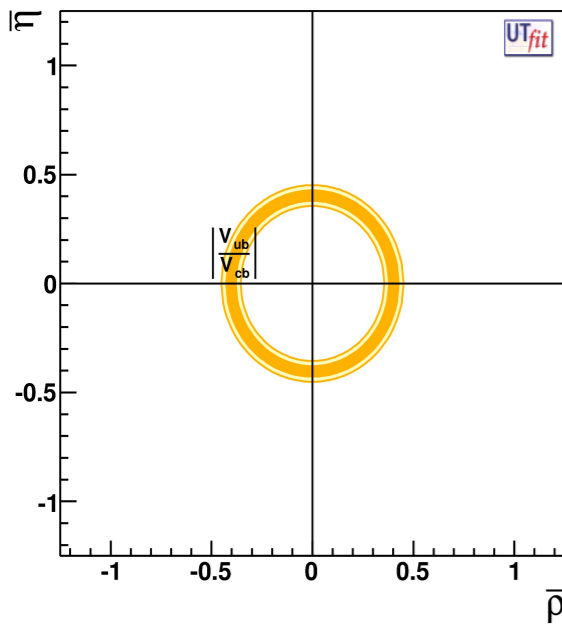
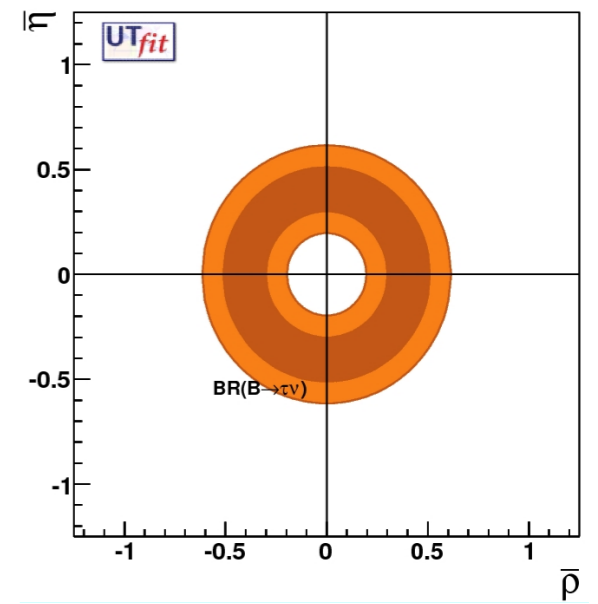

$|V_{ub}/V_{cb}|$

(semileptonic decays)

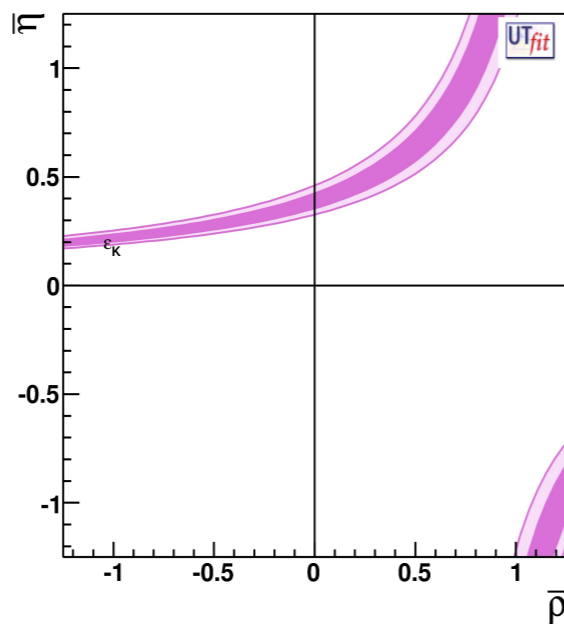

ϵ_K

(CPV in $K - \bar{K}$)

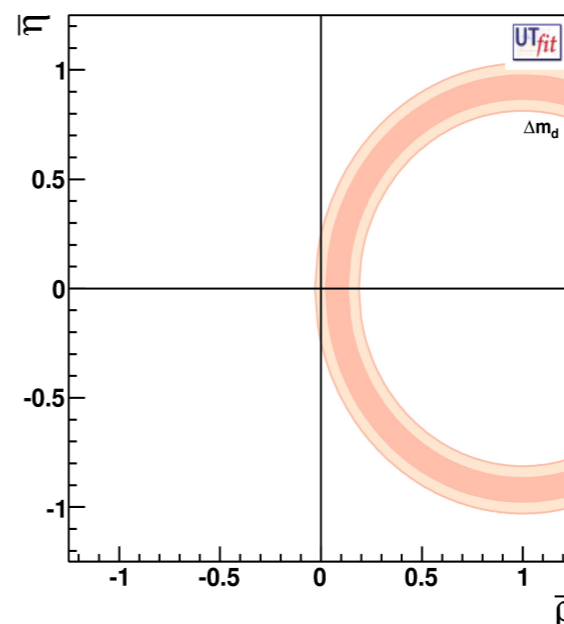

Δm_d

($B_{d,s} - \bar{B}_{d,s}$)

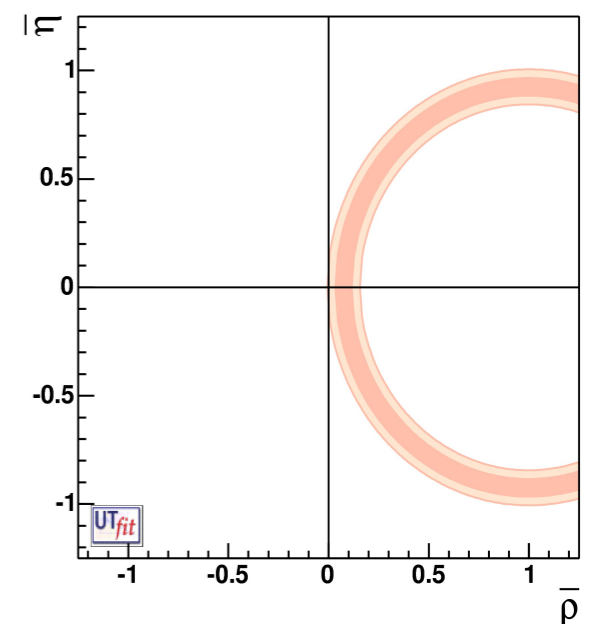

$\Delta m_d / \Delta m_s$

SM UT Analysis

@ 95% prob

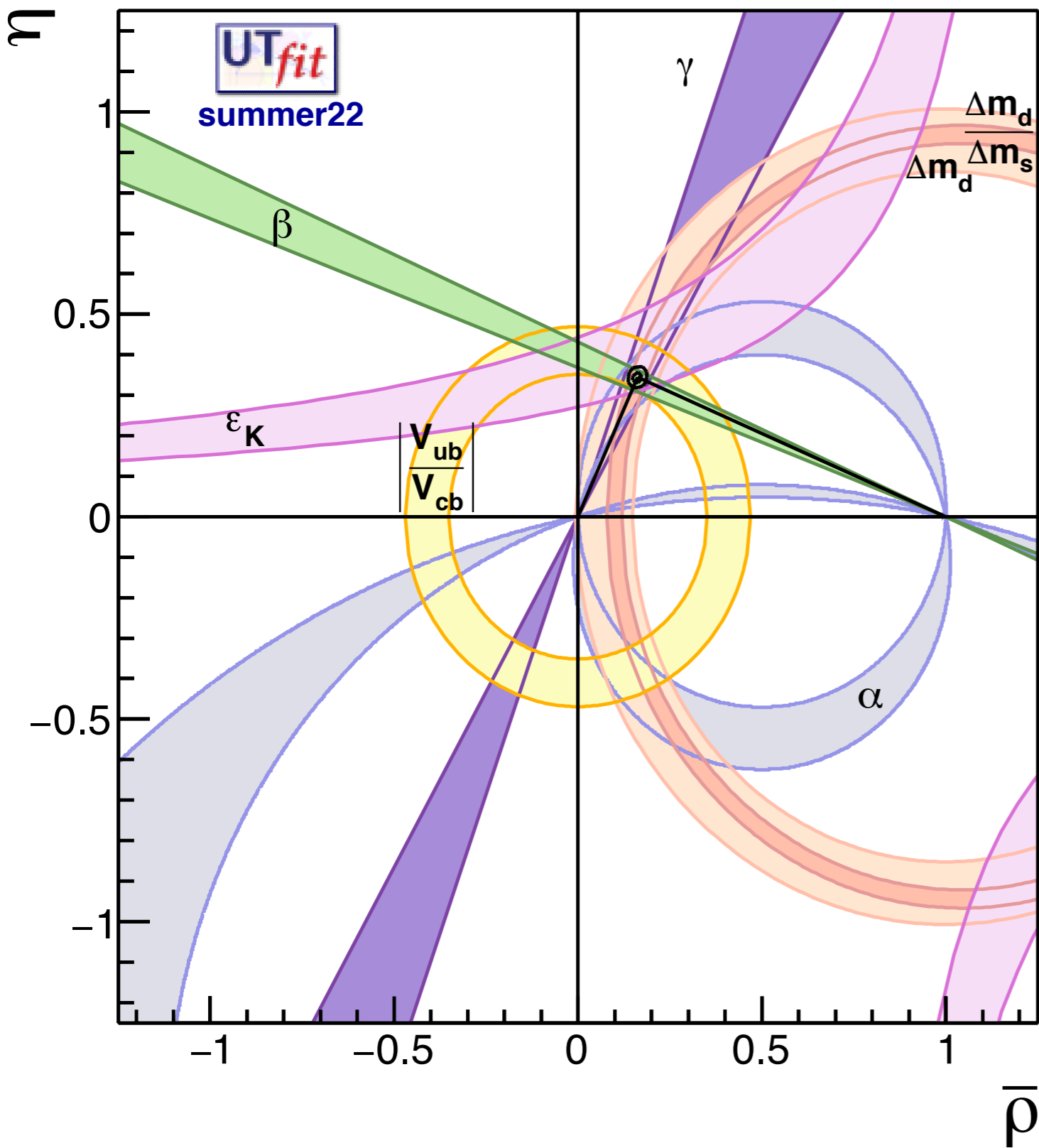

$$\bar{\rho} = 0.161 \pm 0.009 \sim 6\%$$

$$\bar{\eta} = 0.344 \pm 0.010 \sim 3\%$$

ZOOMED-IN SM UT

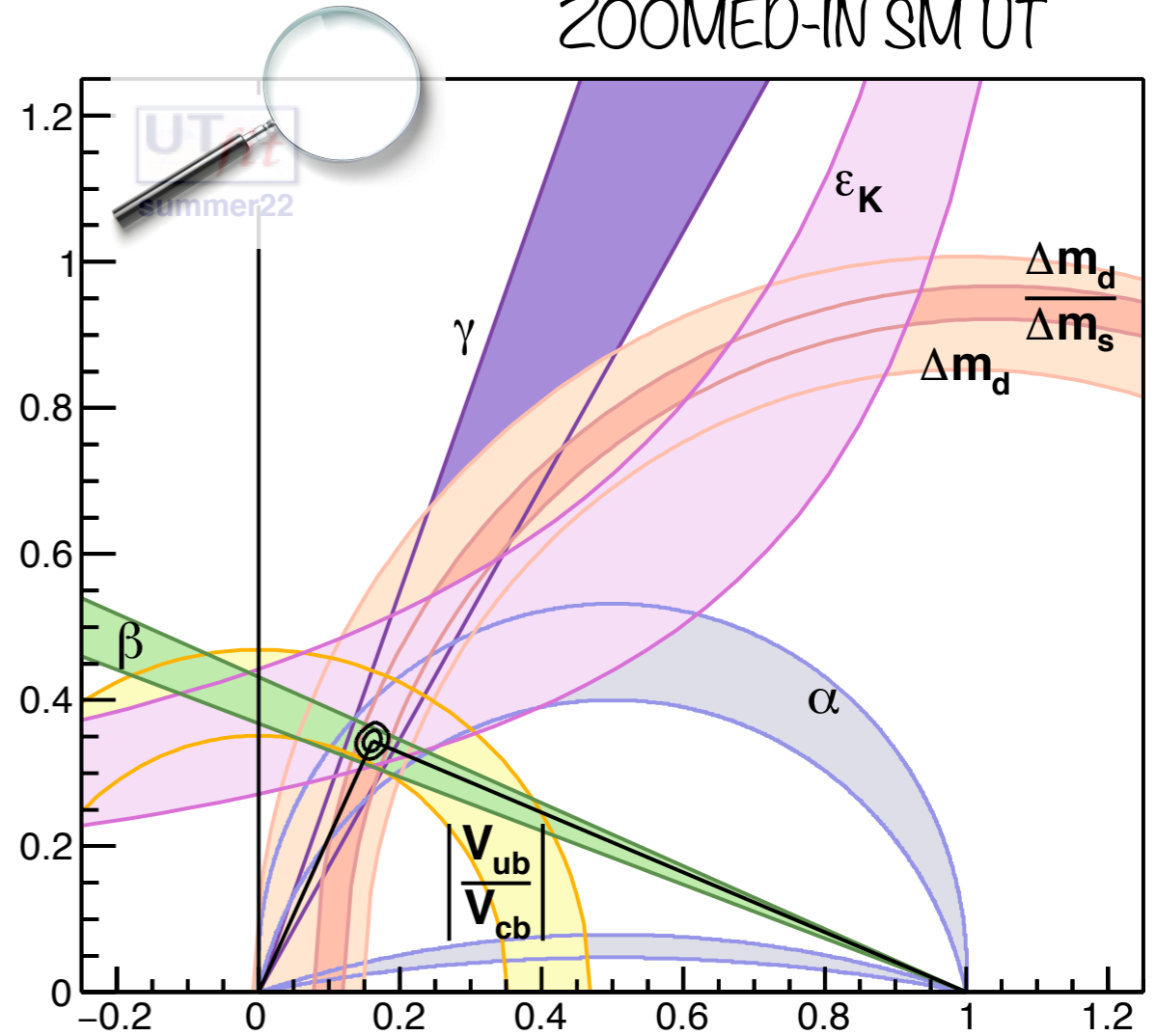

ANOTHER FLAVOR PROBLEM

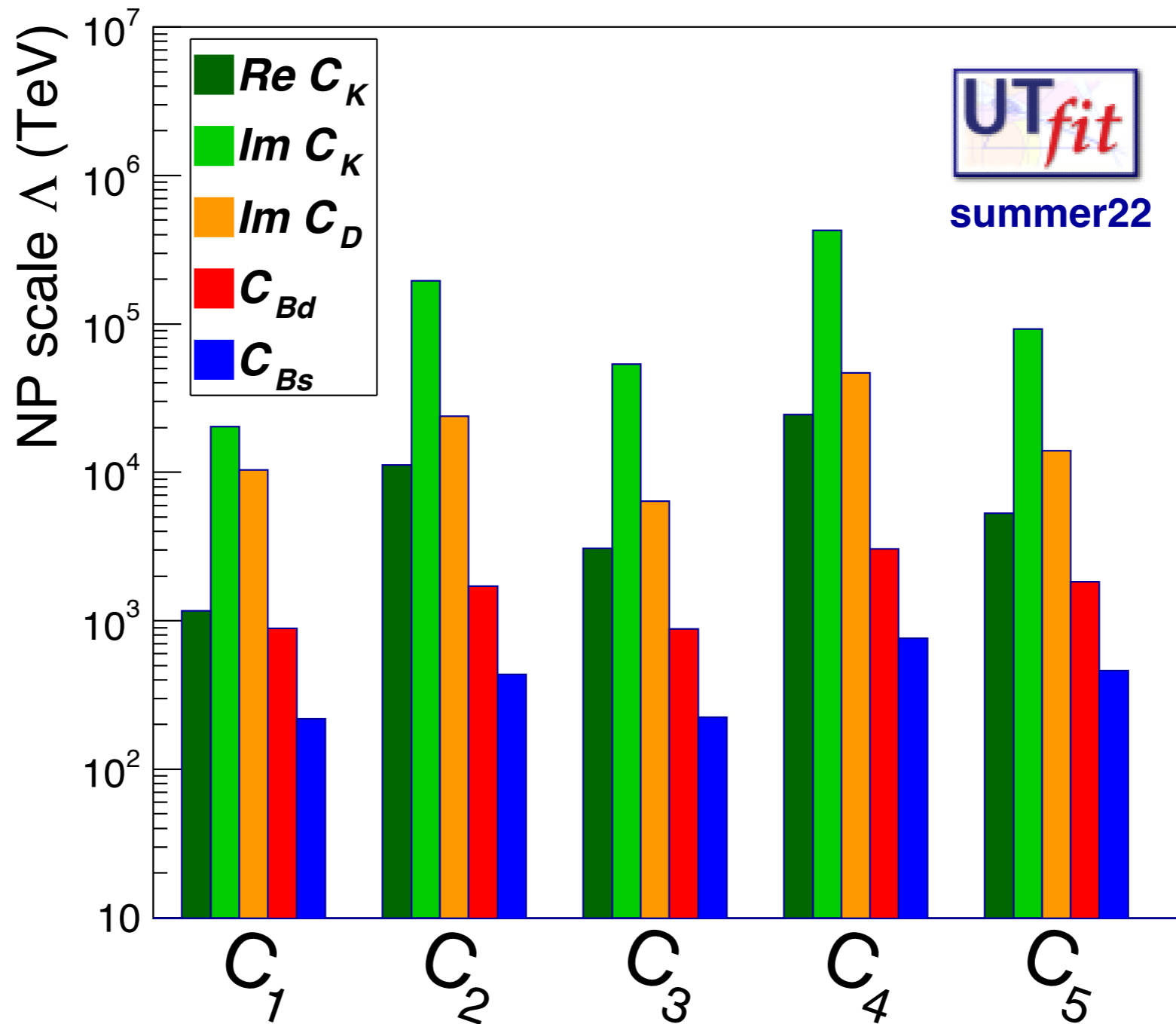

Generic source of Flavor / CP violation \rightarrow high NP scale



Lessons from UTA

- (i) SM UTA: Towards % precision, overall consistency very good
- (ii) NP UTA: Going beyond the SM = facing big challenges

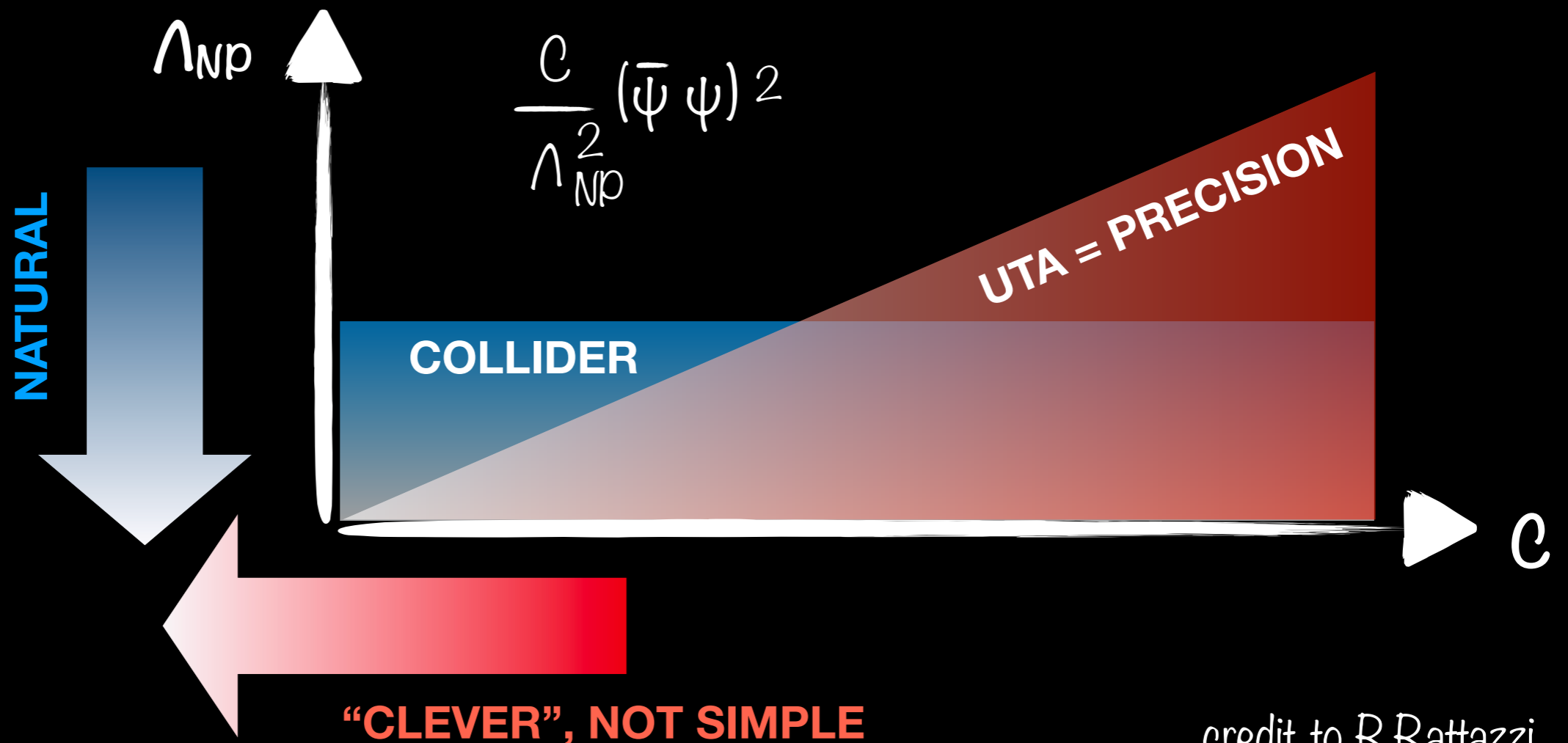

credit to R. Rattazzi
@ GGI '21

TODAY: Important lessons directly from semi-leptonic rare B decays!

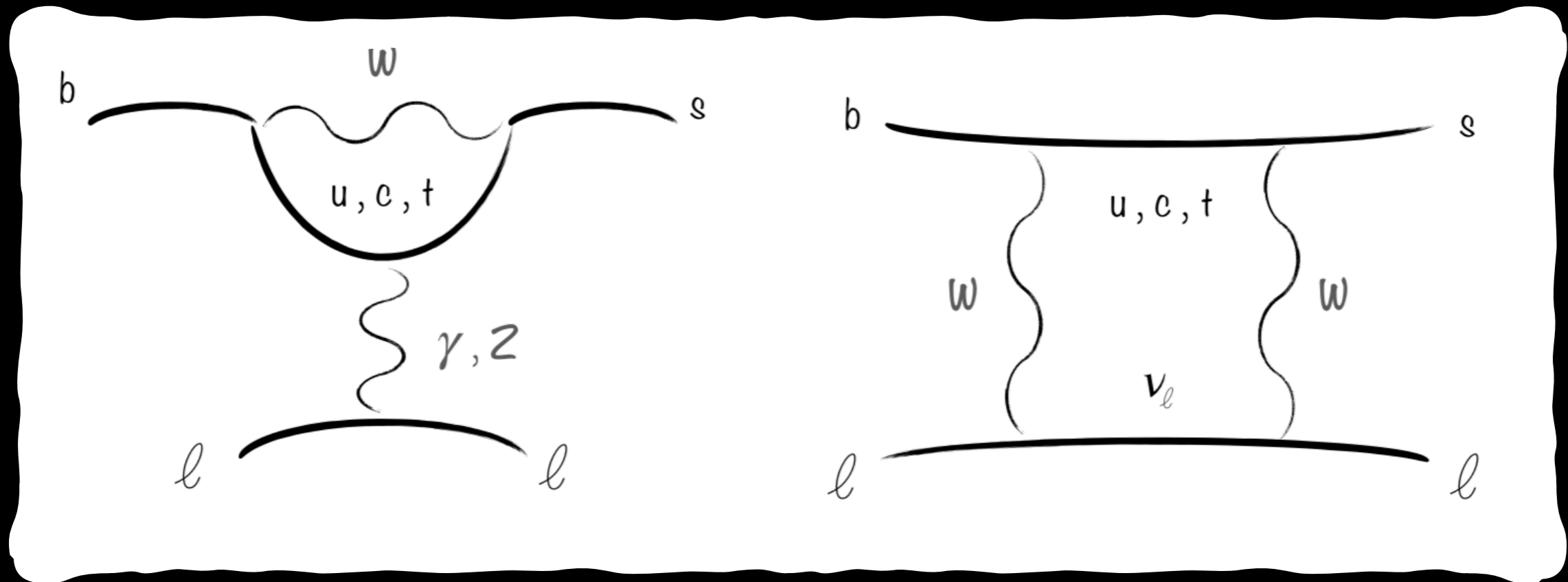

- Flavor Changing Neutral Currents

- only @ loop level in the SM
- GIM suppressed



for
NP!

WHAT IS AN ANOMALY?



a·nom·a·ly

/ə' nāməlē/

noun

1. something that deviates from what is standard, normal, or expected.
"there are a number of anomalies in the present system"



WHAT IS AN ANOMALY?

Article | [Open Access](#) | [Published: 15 March 2022](#)

Test of lepton universality in beauty-quark decays

[LHCb collaboration](#)

[Nature Physics](#) **18**, 277–282 (2022) | [Cite this article](#)

7344 Accesses | **65** Citations | **29** Altmetric | [Metrics](#)

“This article presents evidence for the breaking of lepton universality in beauty-quark decays, with a significance of **3.1 standard deviations**, ...”

B ANOMALIES – What are we talking about?

Hints for **Lepton Universality Violation (LUV)**

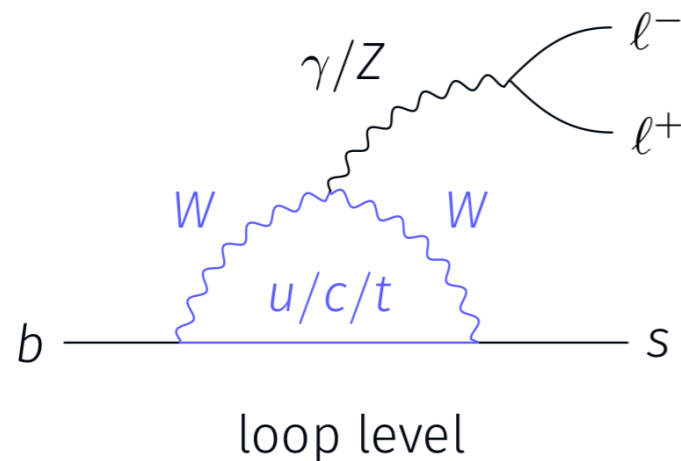
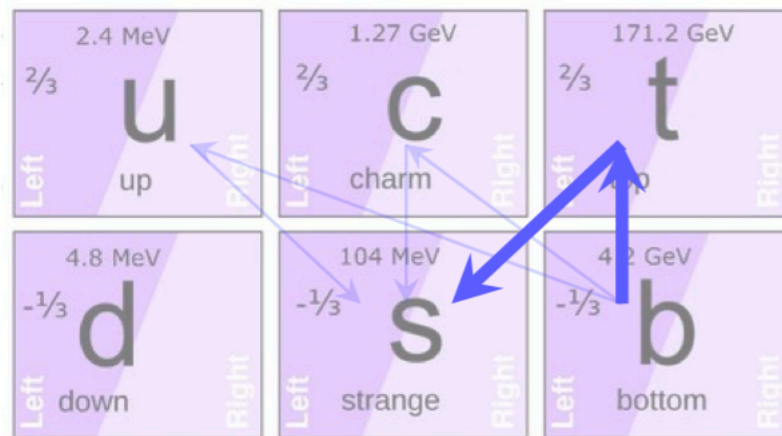

Adding 2015 and 2016 data, R_K becomes:

$$R_K = 0.846^{+0.060}_{-0.054}(\text{stat.})^{+0.016}_{-0.014}(\text{syst.})$$

@LHCb

$\sim 2.5 \sigma$ from SM.

[PRL 112 \(2019\) 191801](#)

BELLE also measured R_K
 BELLE-CONF-1901
 Compatible with LHCb data
 (but also with SM prediction).

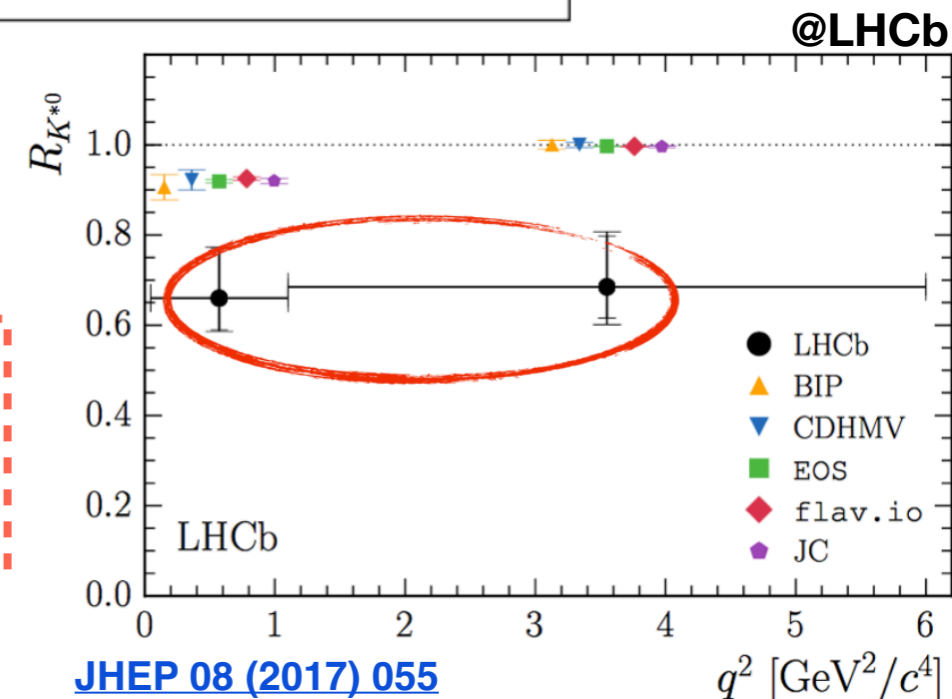

$$R_{K^{(*)}} \equiv BR(B \rightarrow K^{(*)} \mu^+ \mu^-) / BR(B \rightarrow K^{(*)} e^+ e^-)$$

Theoretically very “clean” [1605.07633]

Suppose we could test matter only with long wave-length photons:

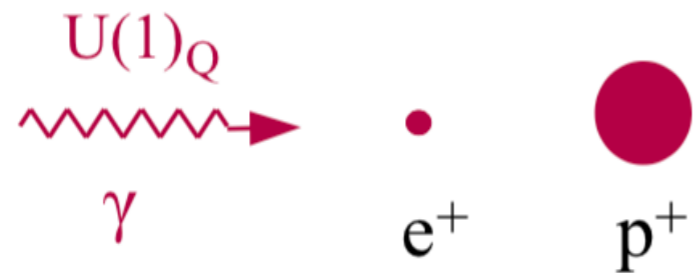

we would conclude that these two particles are “identical copies” but for their mass ...

This is exactly the same (*potentially misleading*) argument we use to infer flavor universality in the SM...

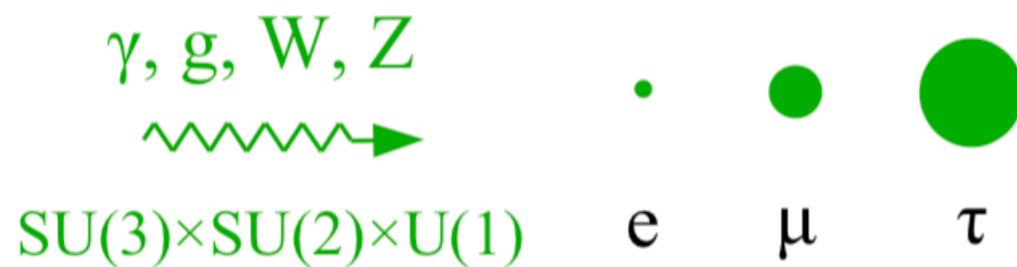

These three (families) of particles seems to be “identical copies” but for their mass ...

3 “identical” families could be an *accidental* property @ low E



LEPTON UNIVERSALITY VIOLATED
 IN THE UV (LIKE BARYON NUMBER)

B ANOMALIES : BEYOND $R_{K^{(*)}}$

$\text{BR}(B_s \rightarrow \mu^+ \mu^-)$ also “clean” [ATLAS + CMS + LHCb]

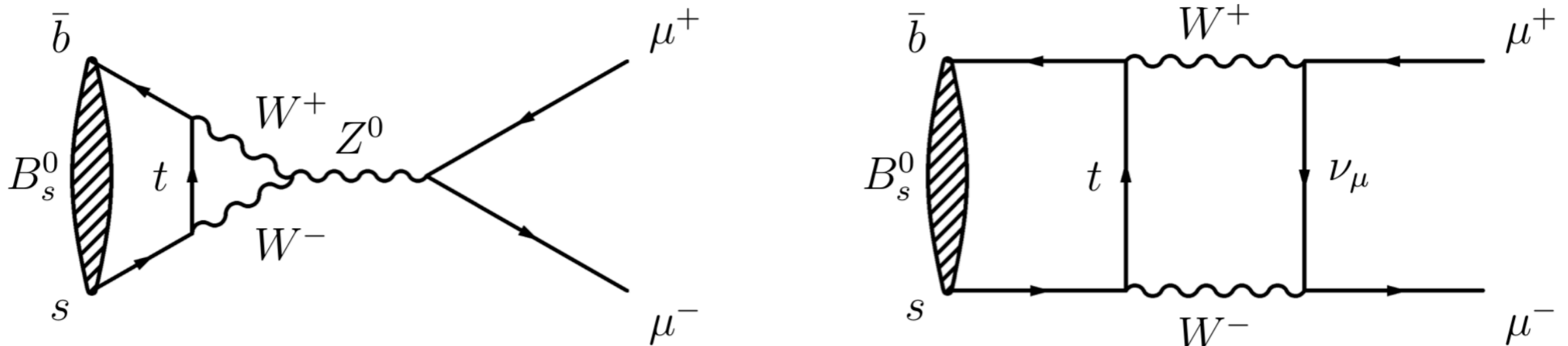

- Dominated by short distance, purely leptonic final state
- Contrary to LUV ratios, directly sensitive to muons

B ANOMALIES : A (COOL!) PIC ~ 2022

NP EVIDENCE @
MORE THAN 6 σ

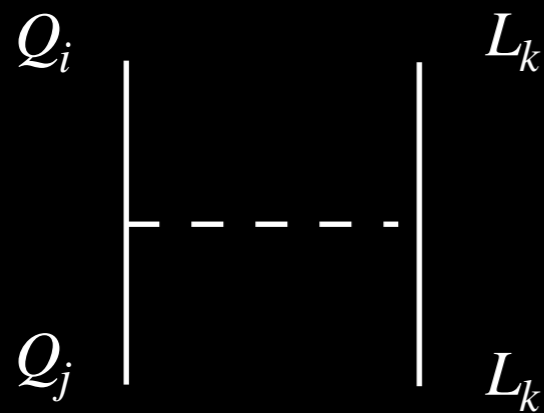

Z' - like

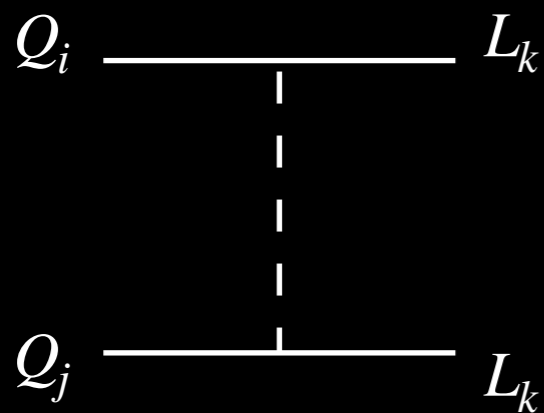

Leptoquark - like

$$O_{2223}^{LQ} = \bar{L}_2 \gamma_\mu L_2 \bar{Q}_2 \gamma^\mu Q_3$$

[2011.01212,
2110.10126]

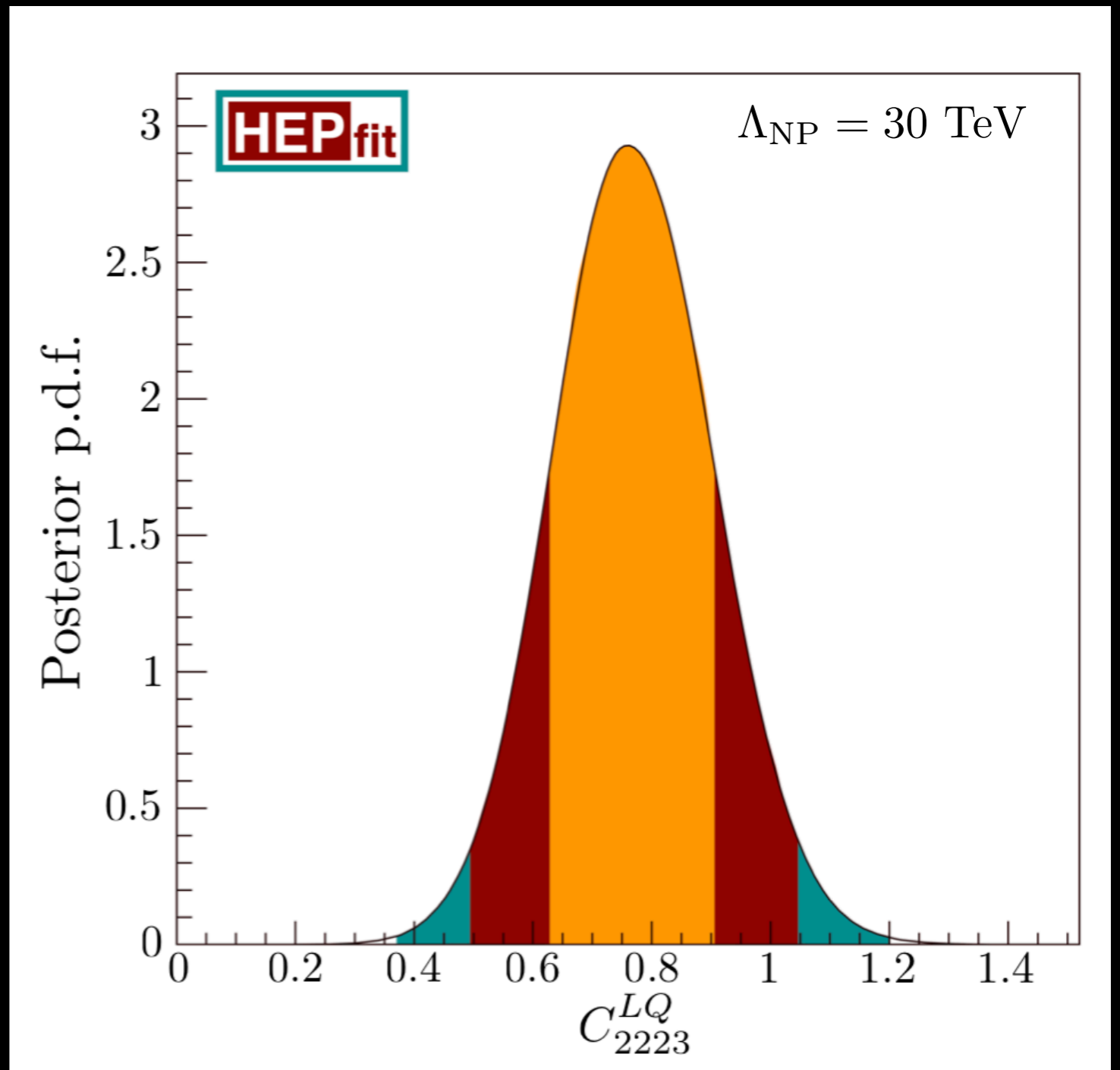

New Physics (NP) \rightarrow Standard Model (SM)



2022

2023

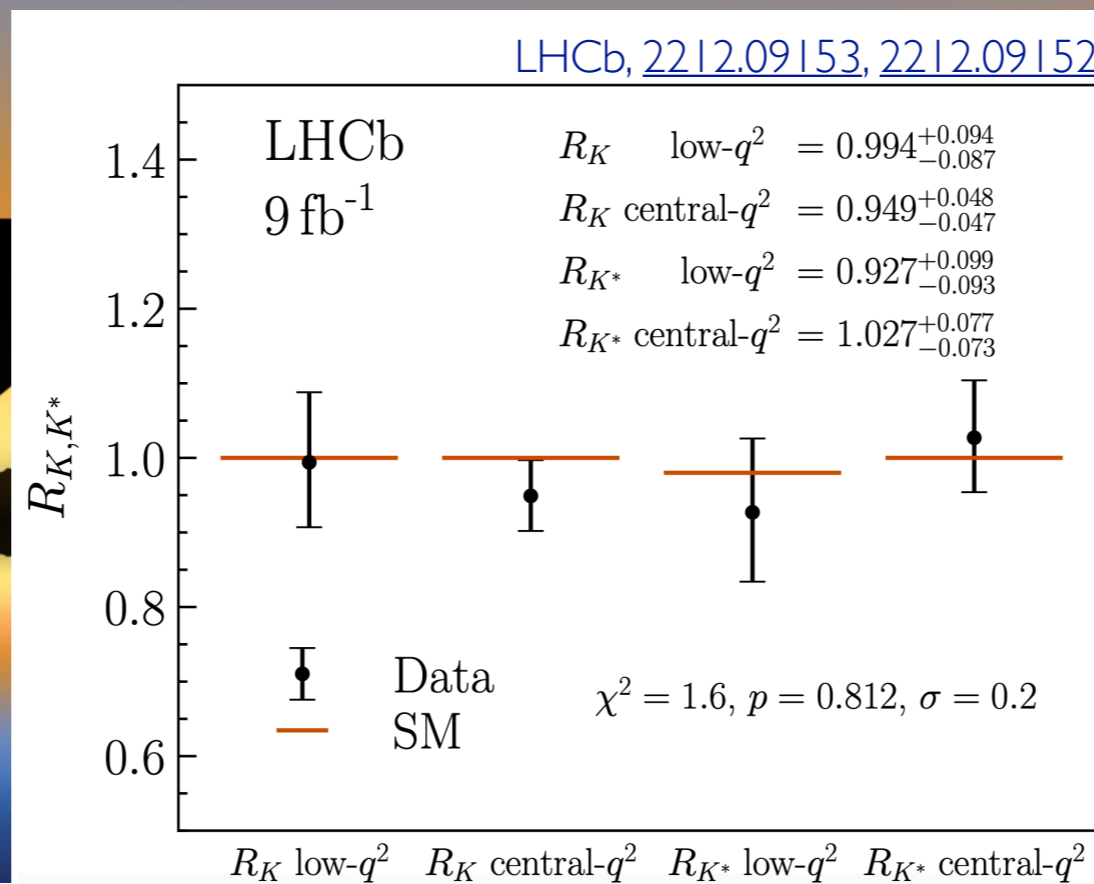

BIG JUMP NOT ONLY DUE TO THE RATIOS ...

Experiment	Measurement [10 ⁻⁹]	$\Delta\chi^2$	Reference
Average	3.45 ± 0.29	3.94	$p = 0.27$ (ndf=3)
PDG	$3.01^{+0.36}_{-0.33}$		pdgLive
CMS	$3.83^{+0.38}_{-0.36}^{+0.24}_{-0.21}$	0.85	inspire id 2110198
LHCb	$3.09^{+0.46}_{-0.43}^{+0.15}_{-0.11}$	0.56	Phys.Rev.D 105 ,012010 (2022)
ATLAS	$2.8^{+0.8}_{-0.7}$	0.67	JHEP 04 ,098 (2019)
CDF	13^{+9}_{-7}	1.86	Phys.Rev.D 87 ,072003 (2013)

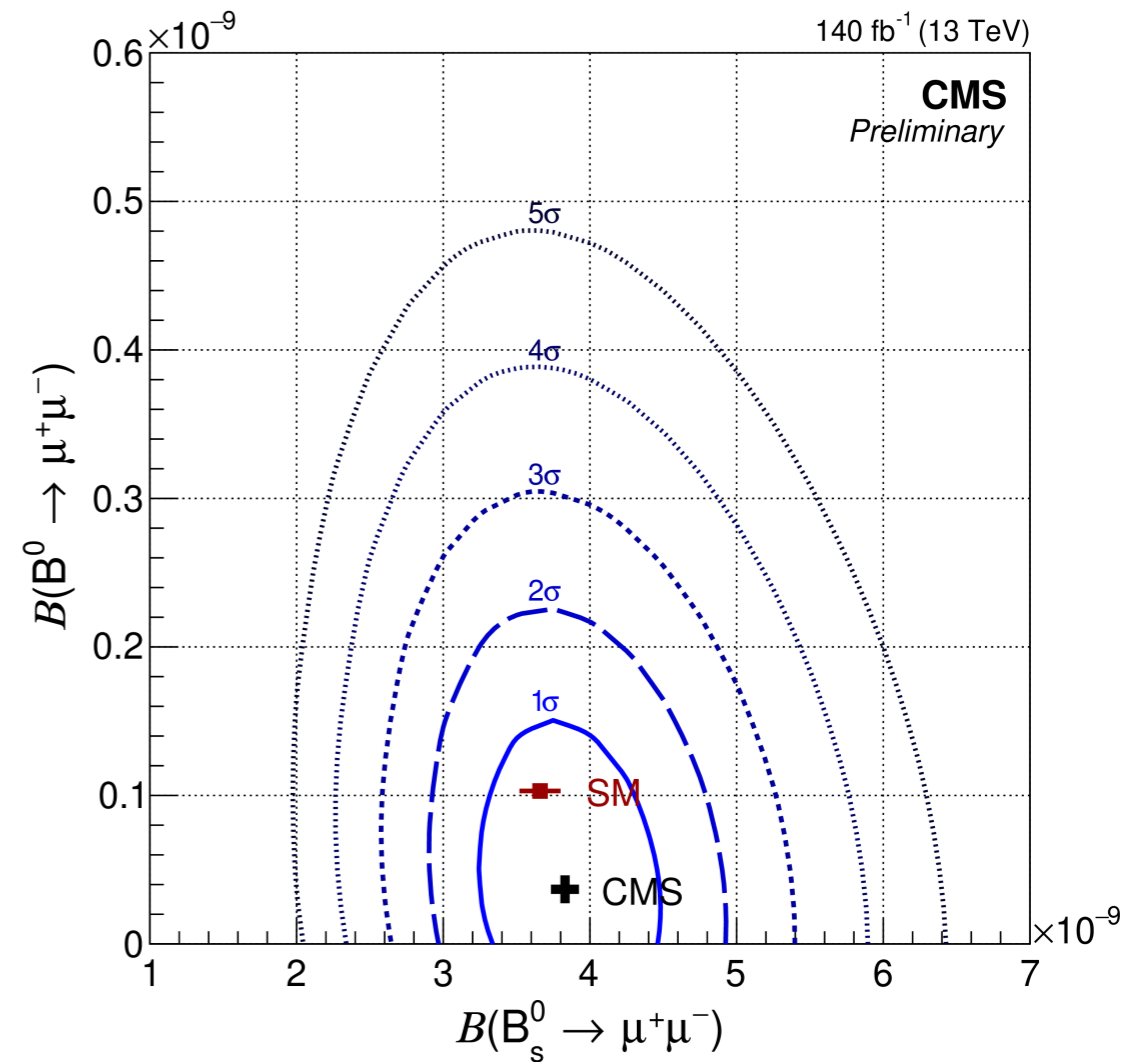

$$\mathcal{B}(B_s^0 \rightarrow \mu^+ \mu^-)$$

Oct 22

$$B(B_s^0 \rightarrow \mu^+ \mu^-)$$

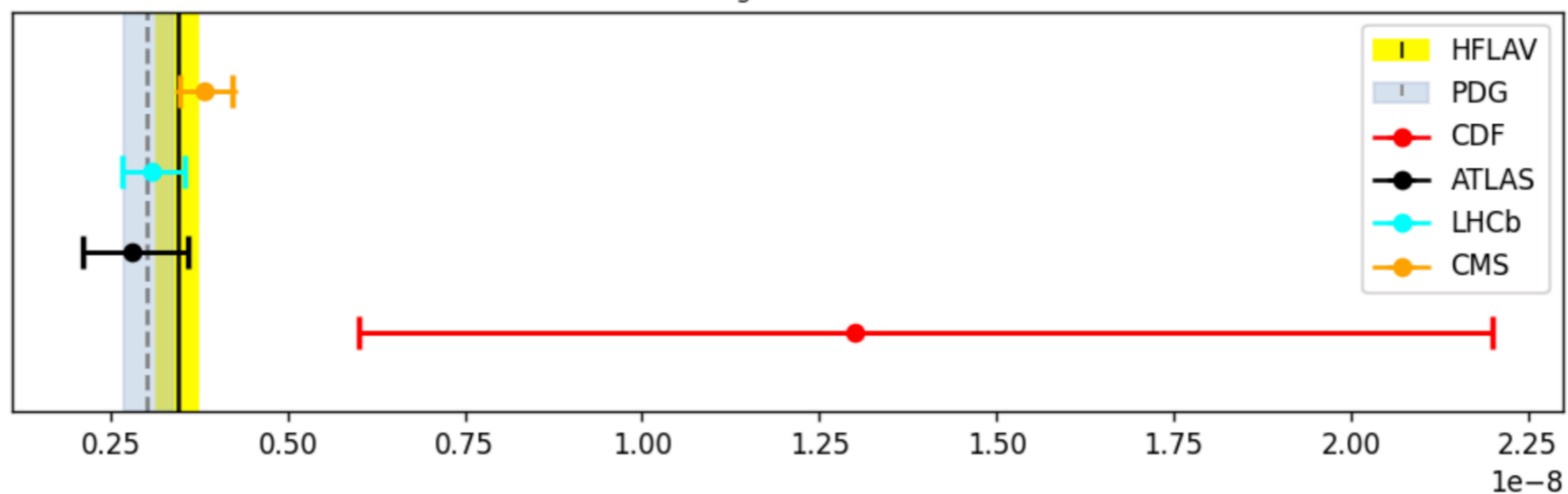

A



Summary

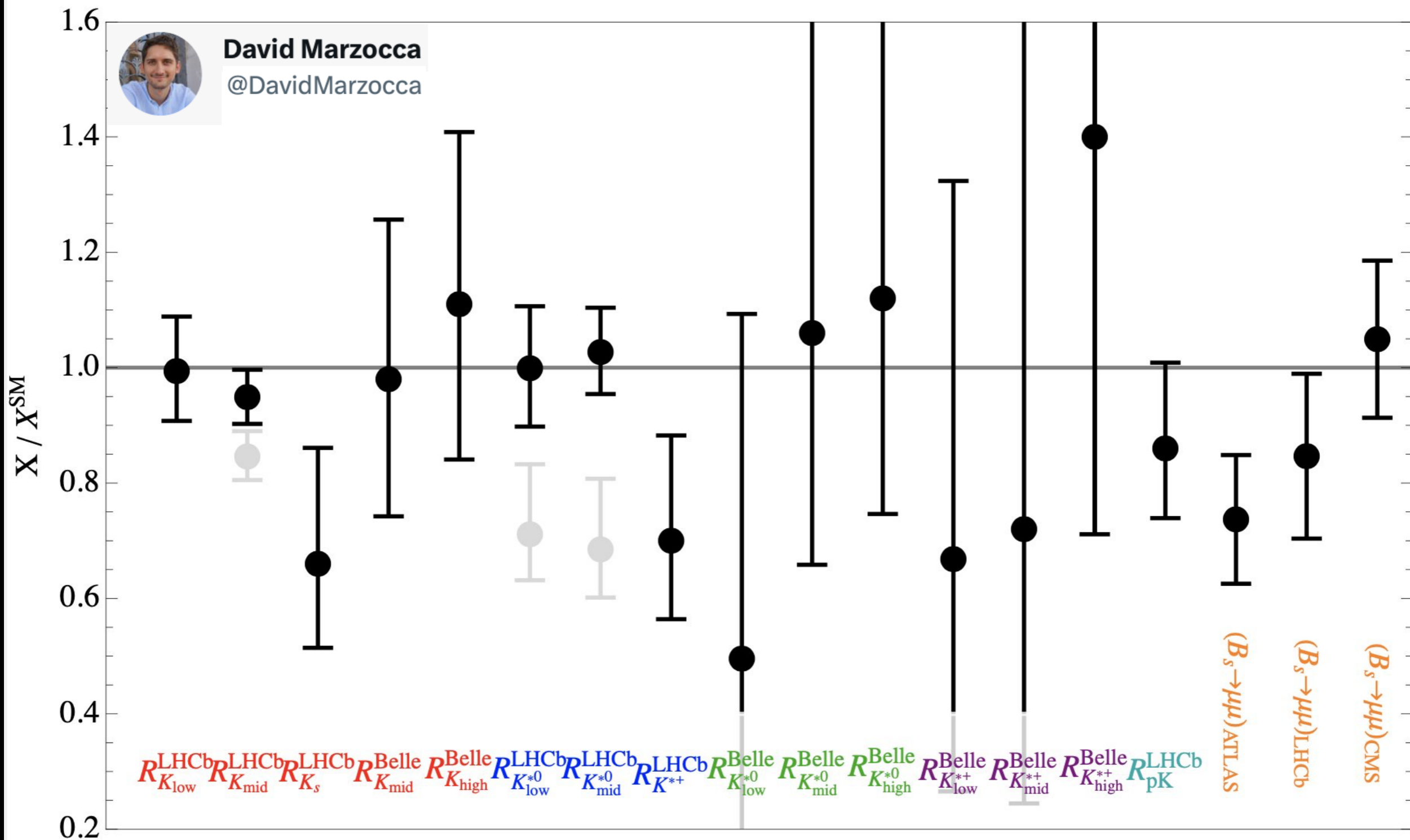

LIFE IS ALL ABOUT BALANCE...

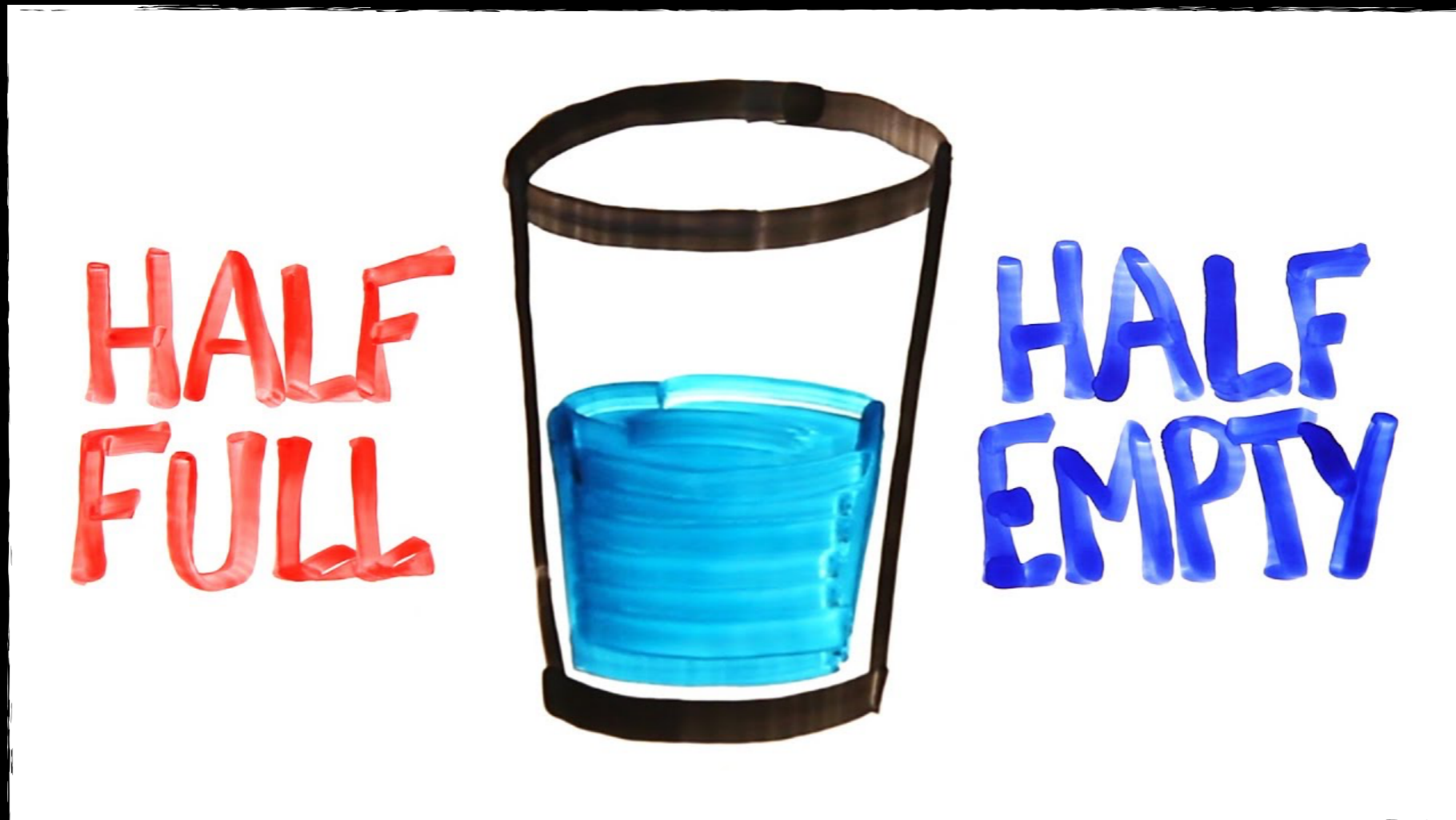

Hints for NP effects in the same class of FCNCs

ANGULAR ANALYSIS
OF $M \rightarrow V \mu \mu$

[$M = B_{(s)}$, $V = K^{*0,+}(\phi)$]

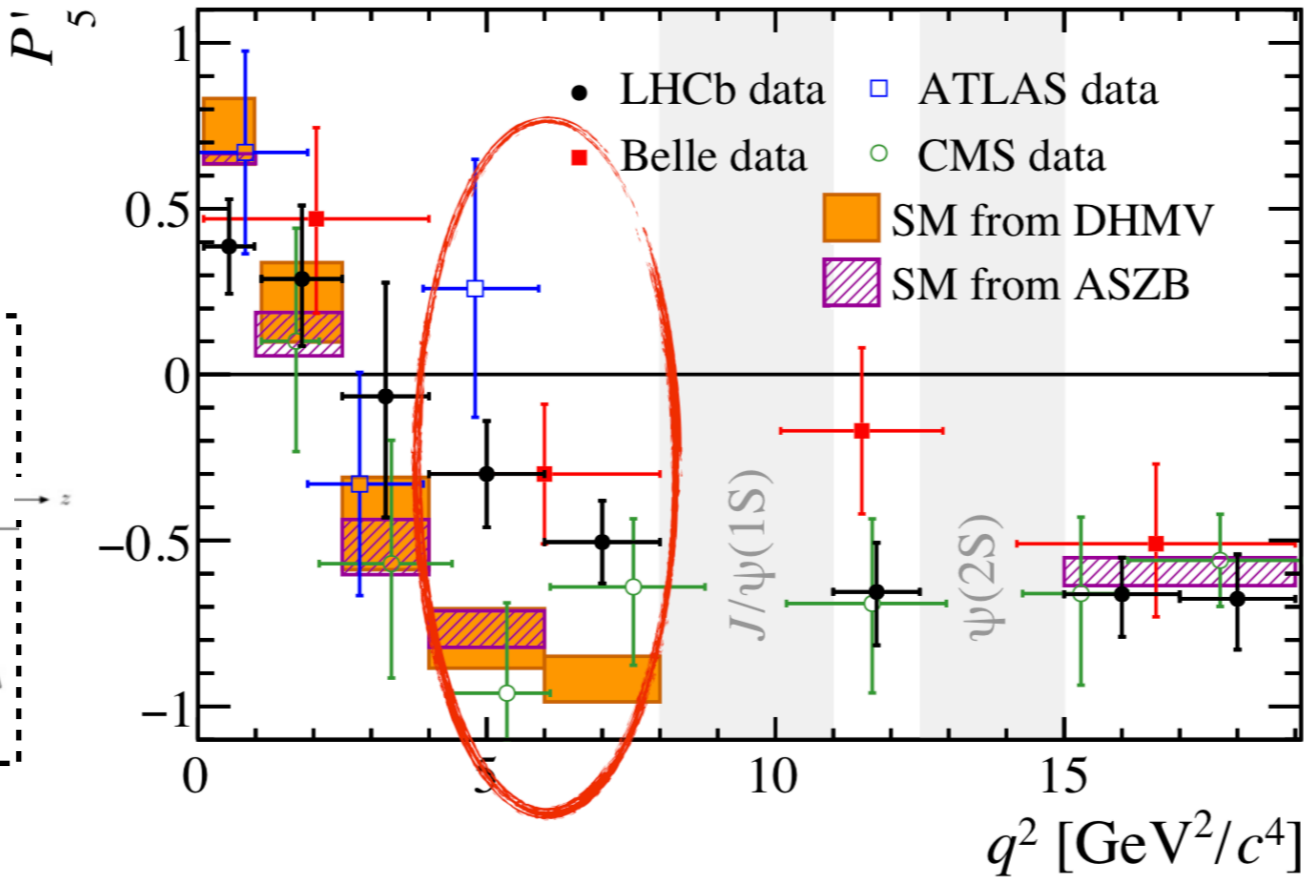
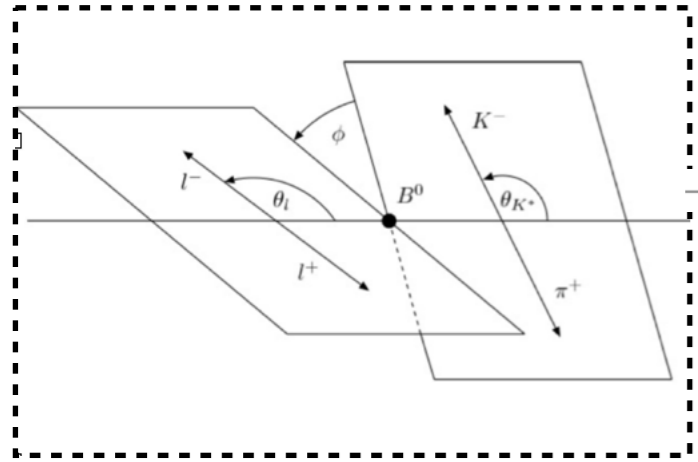

BRs, same range in q^2

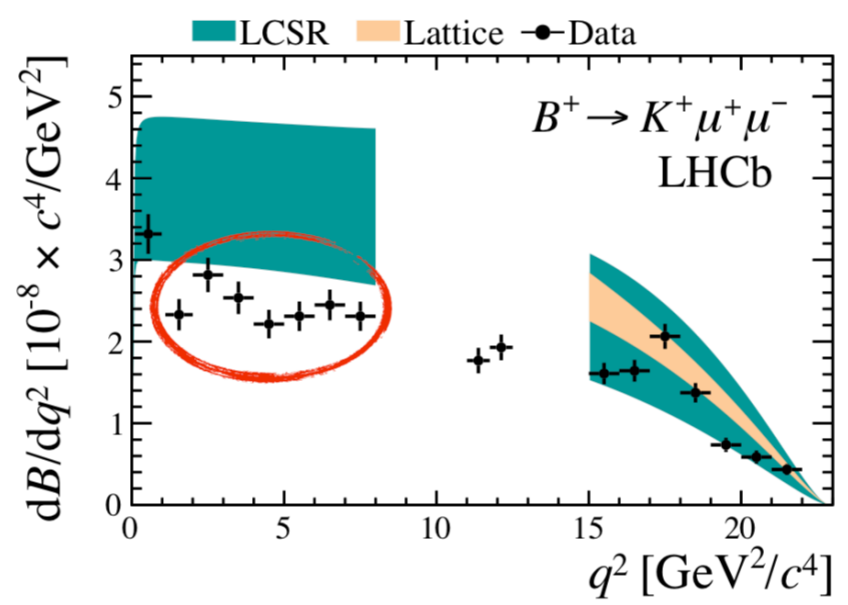
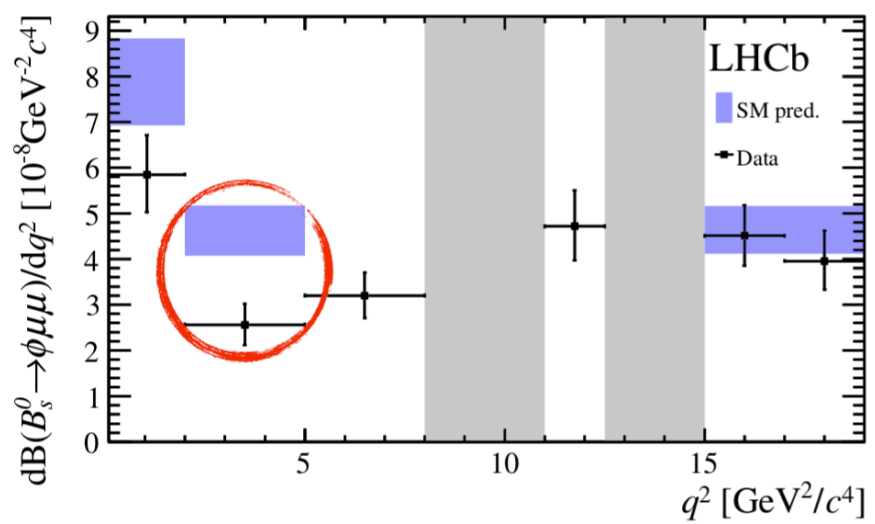

- LHCb
- $4.0 < q^2 / \text{GeV}^2 < 6.0$
- $6.0 < q^2 / \text{GeV}^2 < 8.0$
- 3.4σ
- ATLAS
- $4.0 < q^2 / \text{GeV}^2 < 6.0$
- 2.7σ
- BELLE
- $4.0 < q^2 / \text{GeV}^2 < 8.0$
- 2.6σ
- CMS
- No discrepancies!

CONSISTENT vs TIME
Tension in muons @ LHCb
PRL 25, 011802 (2020)

Q: How to address tension in $b \rightarrow s \ell \ell$ data?

- 1) *Experimental problem + theoretical uncertainties*
- 2) *New Physics*

Q: How to address tension in b \rightarrow s ll data?

1) ~~Experimental problem + theoretical uncertainties~~

2) **New Physics !!!**

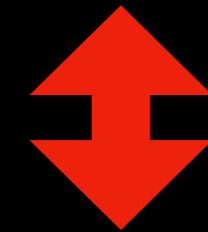

Q: How to address tension in $b \rightarrow s$ ll data?

1) ~~Experimental problem~~ + **theoretical uncertainties**

2) *New Physics ?*

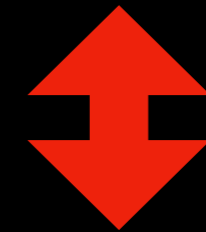

Taming the charm-loop monster...



Towards the Ultimate Precision in Flavour Physics

Marco Ciuchini 



INTERLUDE: ANATOMY OF $B \rightarrow K^{(*)} \ell \ell$

$$H_{\lambda}^{(V)}(q^2) \propto 2 \frac{m_b m_B}{q^2} \left(C_7^{\text{eff}} + \Delta C_{7,\lambda}^{\text{QCDF}}(q^2) \right) \tilde{T}_{\lambda}(q^2) + C_9^{\text{eff}}(q^2) \tilde{V}_{\lambda}(q^2)$$

HELICITY AMPLITUDES : $\lambda = \pm, 0$.

$$+ \Delta C_{9,\lambda}^{\text{QCDF}}(q^2) + 16\pi^2 \frac{m_B^2}{q^2} \tilde{h}_{\lambda}(q^2),$$

$$H_{\lambda}^{(P)}(q^2) \propto 2 \frac{m_{\ell} m_B}{q^2} C_{10} \left(1 + \frac{m_s}{m_b} \right) \tilde{S}(q^2), \quad H_{\lambda}^{(A)}(q^2) \propto C_{10} \tilde{V}_{\lambda}(q^2).$$

- SHORT DISTANCE @ DIM 6

SM Wilson coeffs @ $\sim m_b$: $C_7 \sim -1/3$, $C_9 \sim 4$, $C_{10} \sim -4$

- FORM FACTORS FOR $B \rightarrow K^{(*)}$

state-of-the-art from LQCD & LCSR computations

- QCD CONTRIBUTIONS FROM C x C & PENGUINS

QCD factorization for leading effects of $O(\Lambda_{\text{QCD}}/m_b)$,

but non-factorizable power corrections also present.



KNOWN UNKNOWN IN $B \rightarrow K^* \ell \ell$

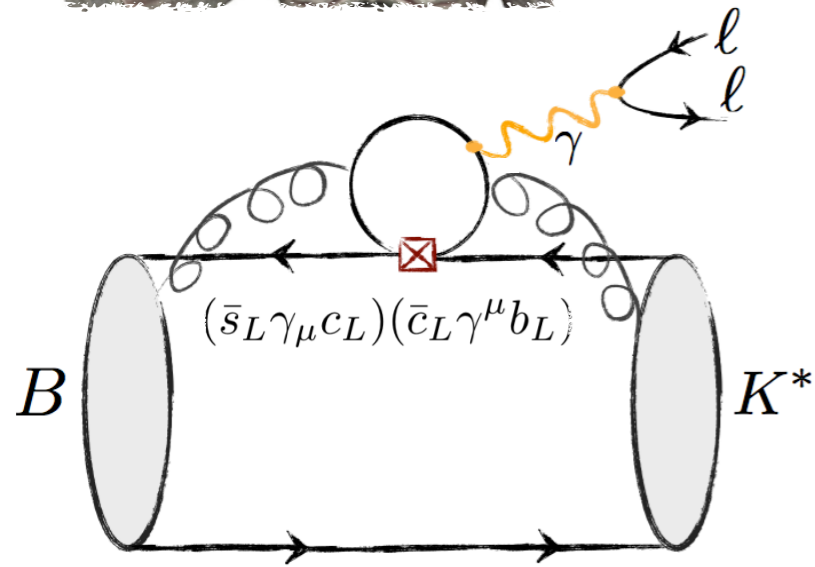

$$h_\lambda(q^2) = \frac{\epsilon_\mu^*(\lambda)}{m_B^2} \int d^4x e^{iqx} \langle \bar{K}^* | T \{ j_{em}^\mu(x) \mathcal{H}_{eff}^{had}(0) \} | \bar{B} \rangle$$

COMPUTED IN
1006.4945 USING:

- i) Light-cone sum rules (LCSR)
- ii) Single soft gluon approximation
- iii) Extrapolation via dispersion rel.

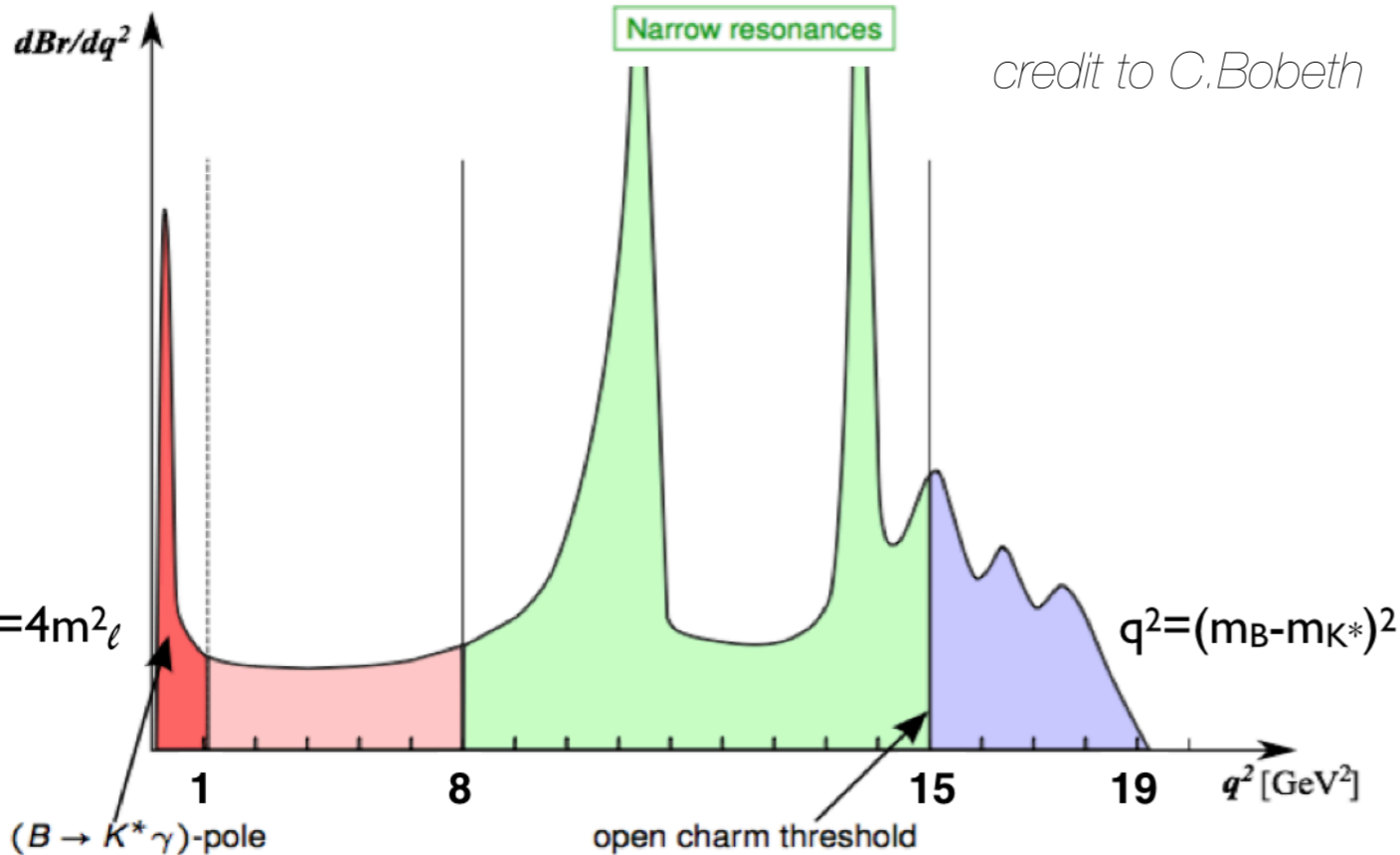

Large Recoil (low q^2)

Low Recoil (high q^2)

“OPTIMISTIC” =
TRUST THIS COMPLETELY!
Pheno - Model - Driven (PMD)

“CONSERVATIVE” =
TRUST THIS PARTIALLY!
Pheno - Data - Driven (PDD)

ANOMALIES IN $B \rightarrow K^* \mu\mu$? [1512.07157 + 2011.01212]

$$h_{0,\pm}(q^2) = \sum_{k=0,1,2} h_{0,\pm}^{(k)} \left(\frac{q^2}{\text{GeV}^2} \right)^k$$

Phenomenological Model Driven (PMD)

Enforce outcome of LCSR + dispersion relations in the entire range of q^2

$$P'_5 = \frac{S_5}{\sqrt{F_L(1 - F_L)}}$$

Descotes-Genon et al. 2013

Phenomenological Data Driven (PDD)

Apply LCSR results only for $q^2 \lesssim \text{GeV}^2$

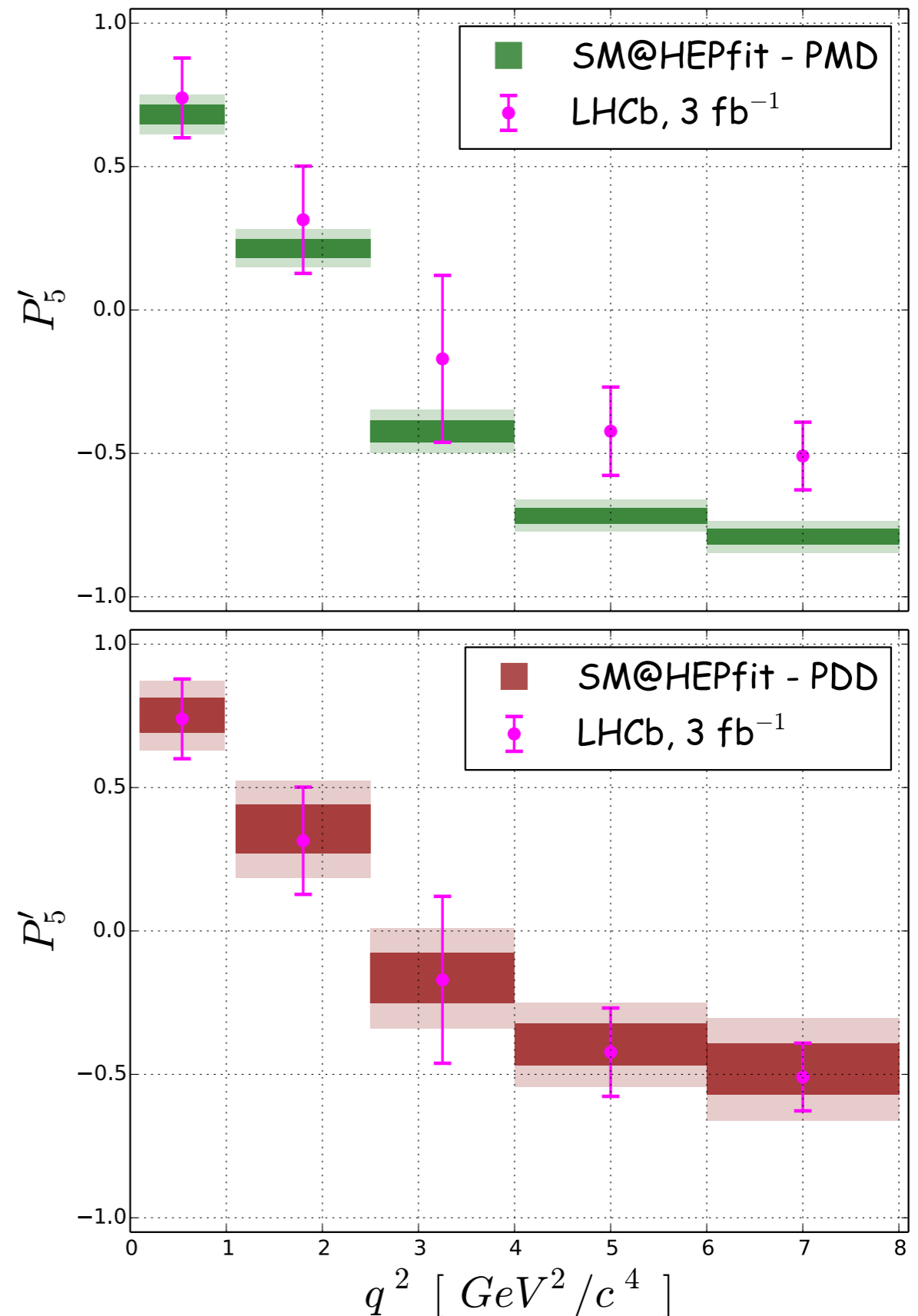

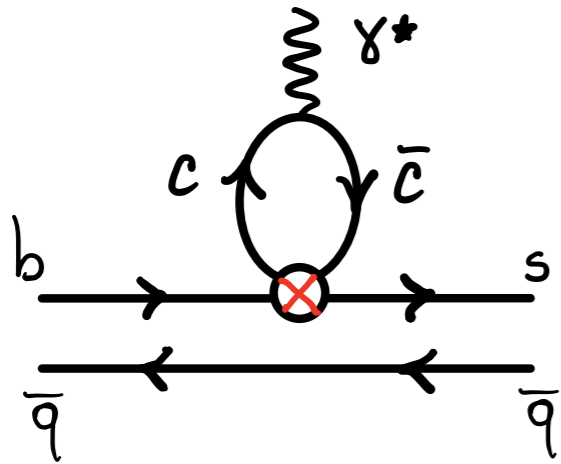

In 2023, this class of charming penguins might be tamed.

[2206.03797]

- 1) LCSR at $q^2 \leq 0$
- 2) z - expansion w/ $B \rightarrow MJ/\psi$ data
- 3) dispersive bounds

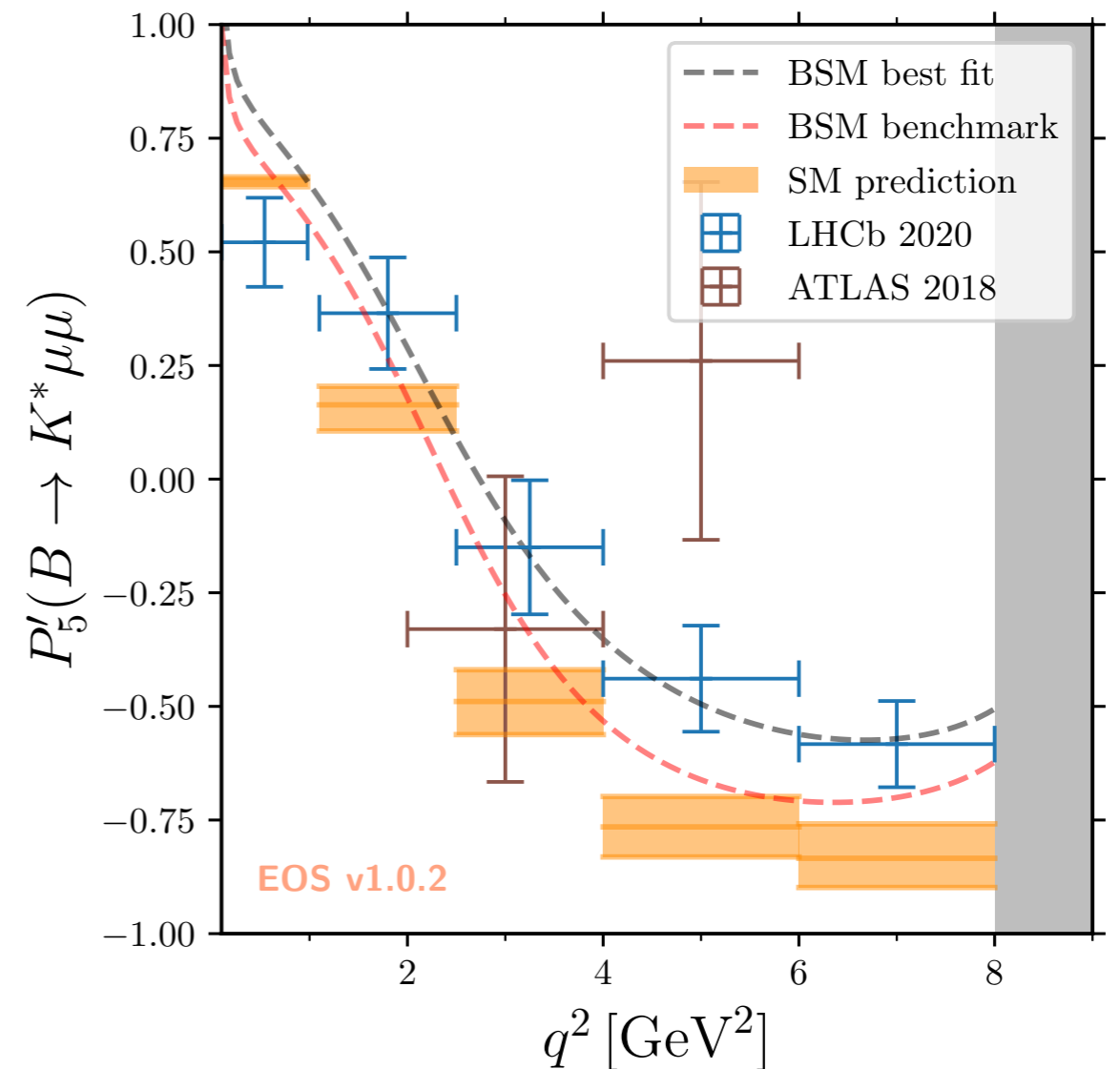
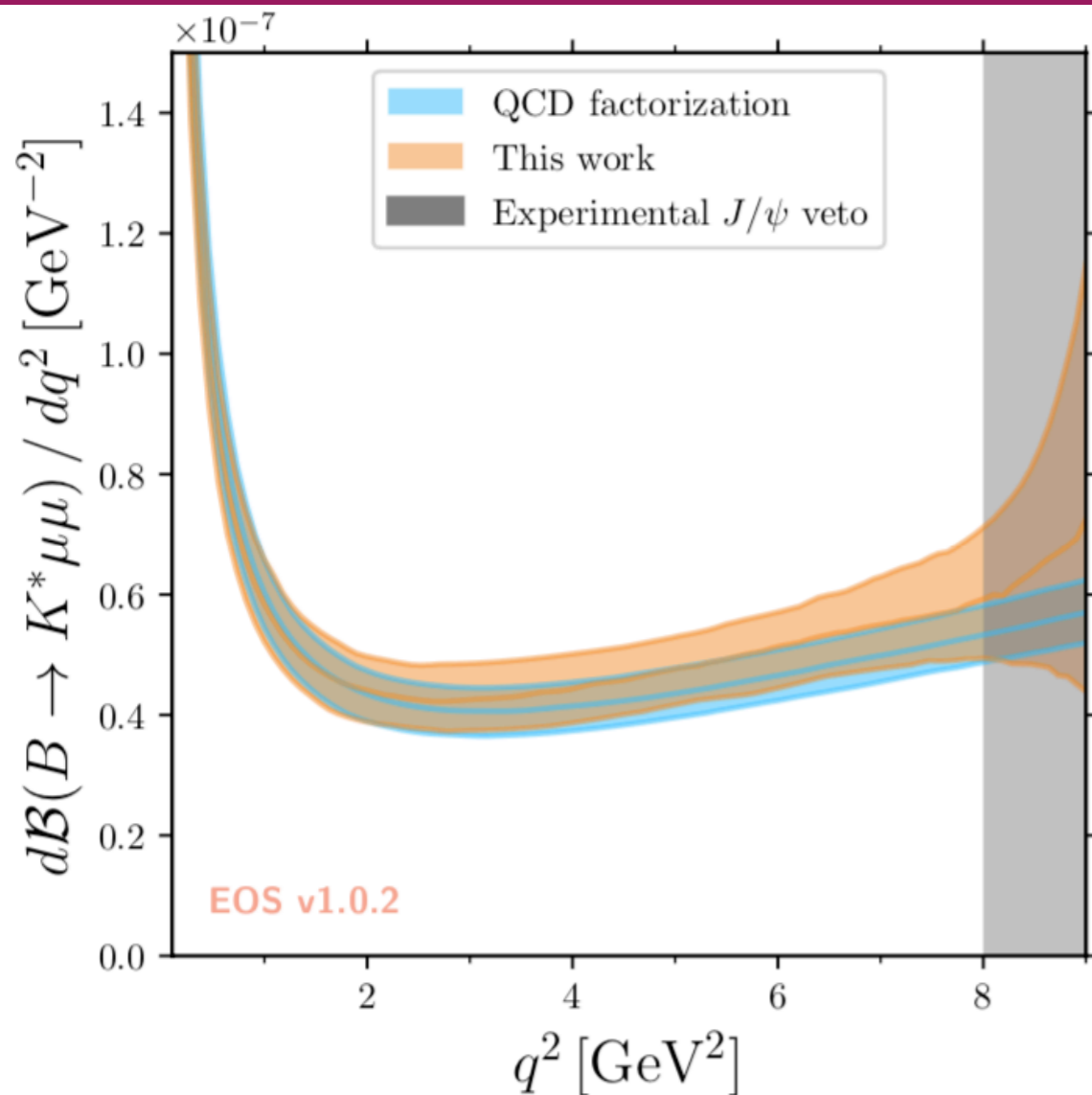

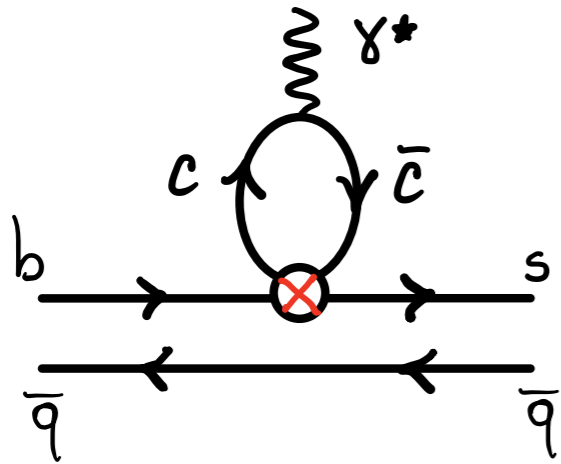

In 2023, this class of charming penguins might be tamed.

[2206.03797]

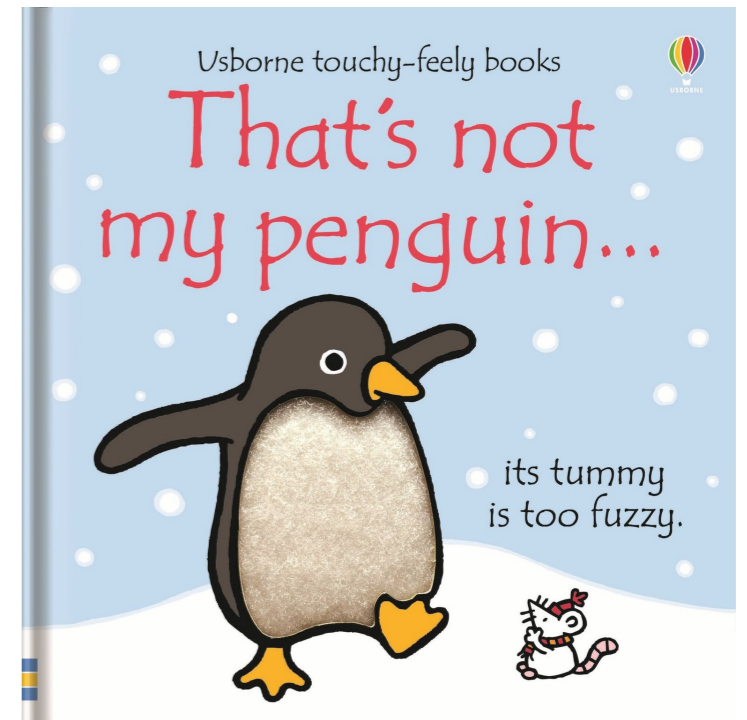

... WHAT ABOUT THOSE ?

[2110.10126 + 2212.10516]

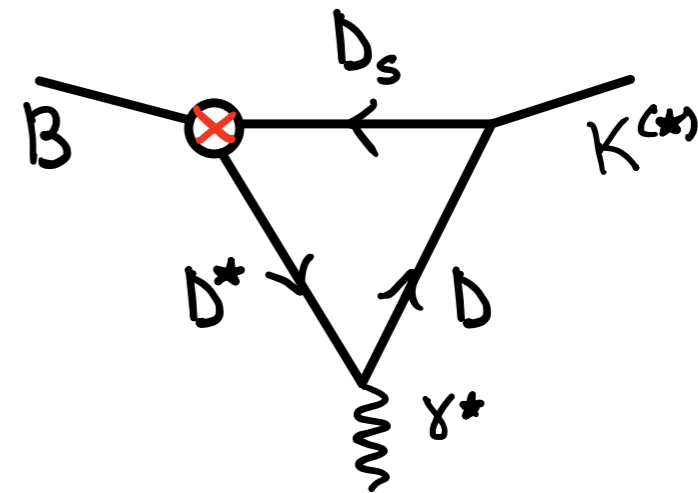
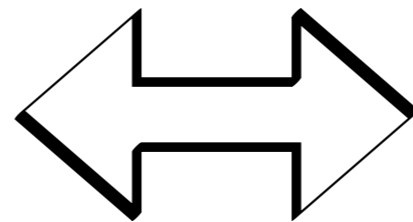
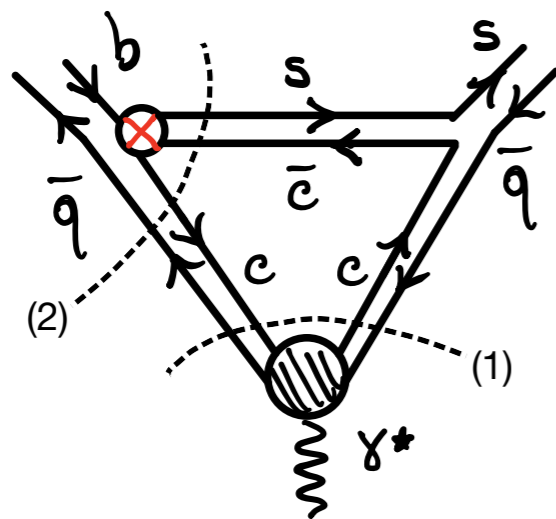

Rescattering from intermediate on-shell hadronic states. These effects NOT captured by any analytic cut solely in q^2 .

NEW data driven approach: no theory input on $h_\lambda^{(k)}$



BEST CODE



HEPfit: a code for the combination of indirect and direct constraints on high energy physics models

J. de Blas^{1,2}, D. Chowdhury^{3,4}, M. Ciuchini⁵, A. M. Coutinho⁶, O. Eberhardt⁷, M. Fedele⁸, E. Franco⁹, G. Grilli di Cortona¹⁰, V. Miralles⁷, S. Mishima¹¹, A. Paul^{12,13,a} , A. Peñuelas⁷, M. Pierini¹⁴, L. Reina¹⁵, L. Silvestrini^{9,16}, M. Valli¹⁷, R. Watanabe⁵, N. Yokozaki¹⁸

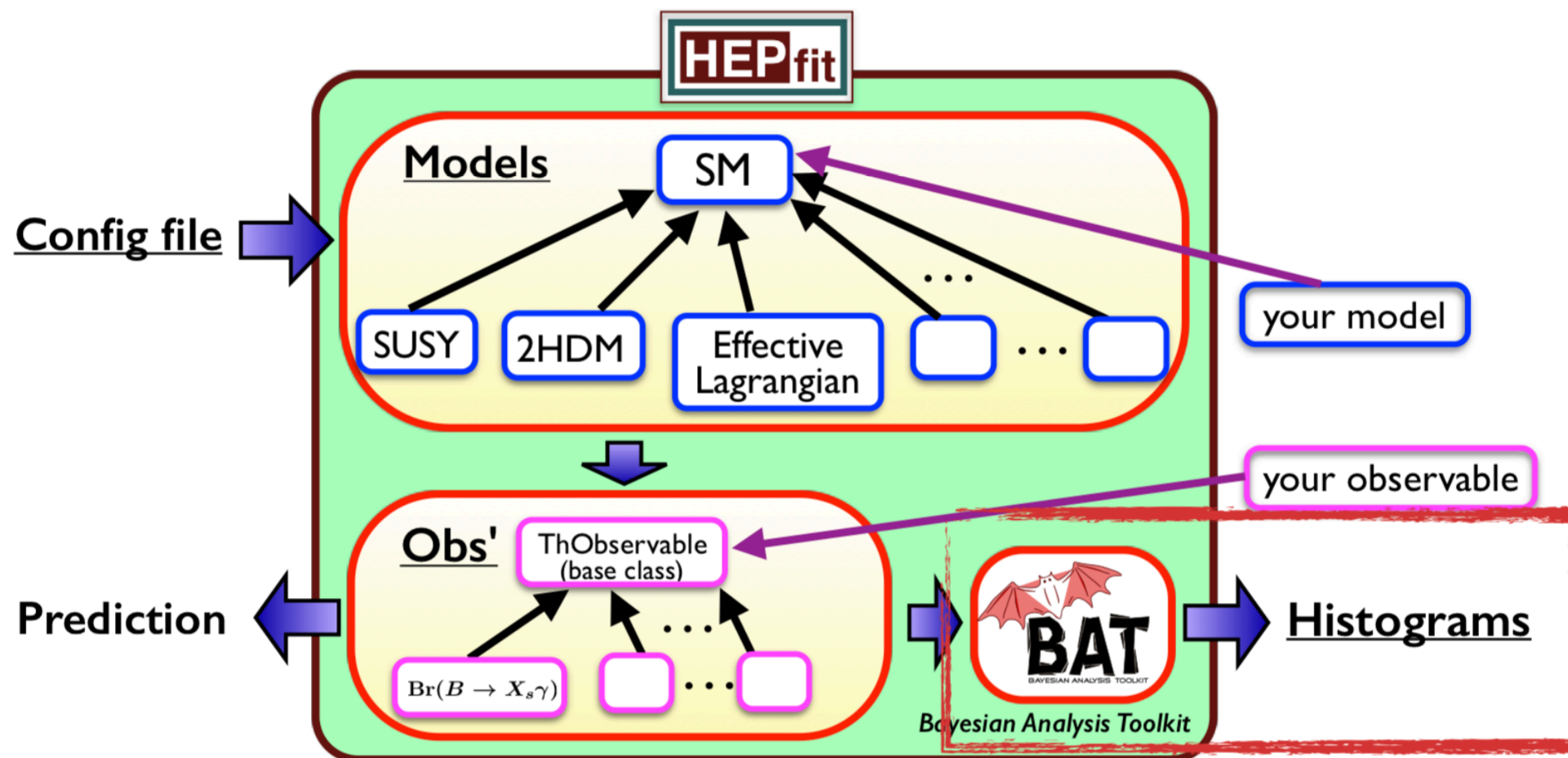

[1910.14012]

<https://hepfit.roma1.infn.it><https://github.com/silvest/HEPfit>

[2212.10516]

B ANOMALIES : CIRCA 2023

SMEFT GLOBAL ANALYSIS:
KEY NP OPERATORS

$$O_{2223}^{LQ} = \bar{L}_2 \gamma_\mu L_2 \bar{Q}_2 \gamma^\mu Q_3$$

$$O_{2322}^{Qe} = \bar{Q}_2 \gamma_\mu Q_3 \bar{e}_2 \gamma^\mu e_2$$

$$C_9 \propto C^{Qe} + C^{LQ}$$

$$C_{10} \propto C^{Qe} - C^{LQ}$$

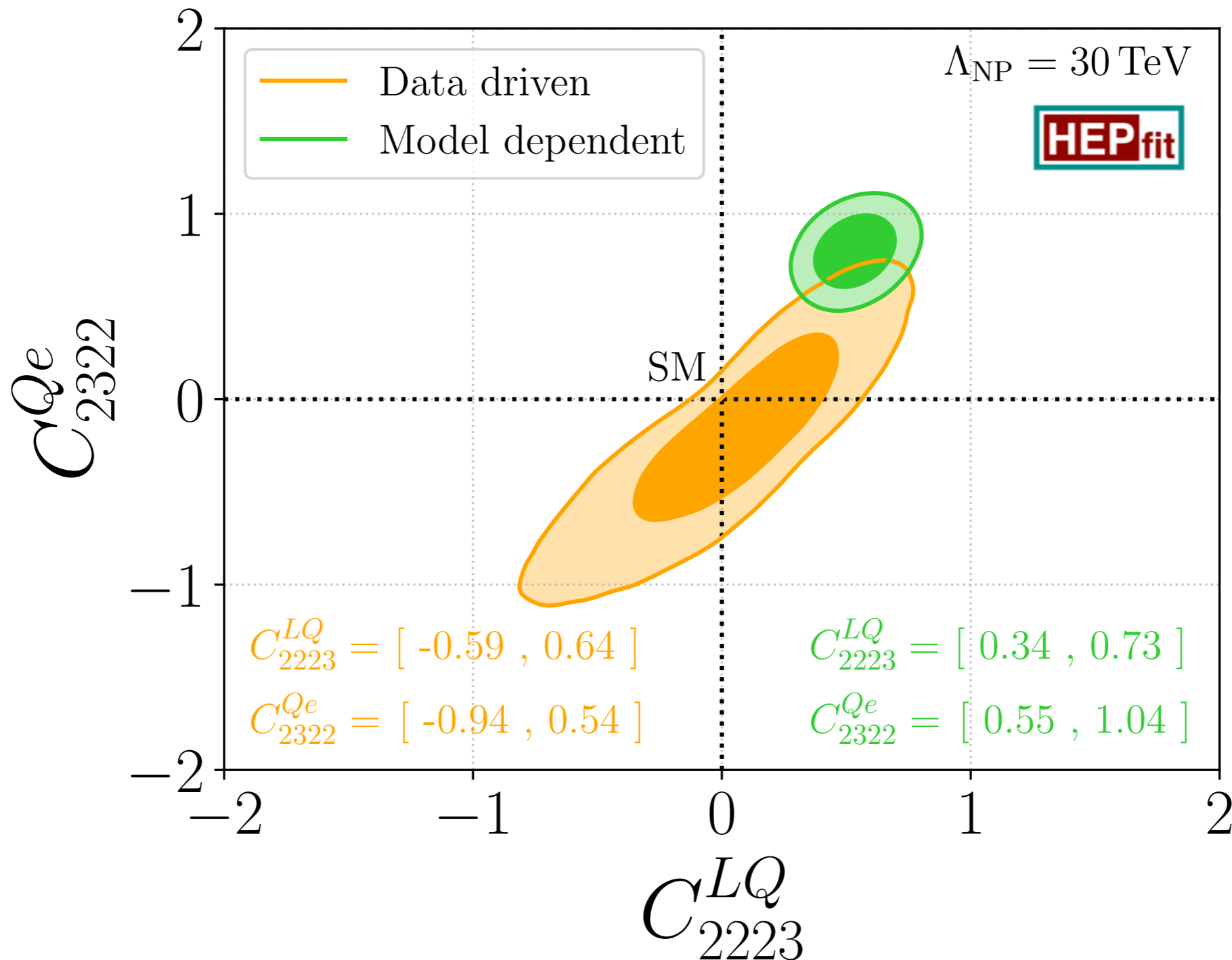

B ANOMALIES : CIRCA 2023

[2212.10516]

QCD ONLY

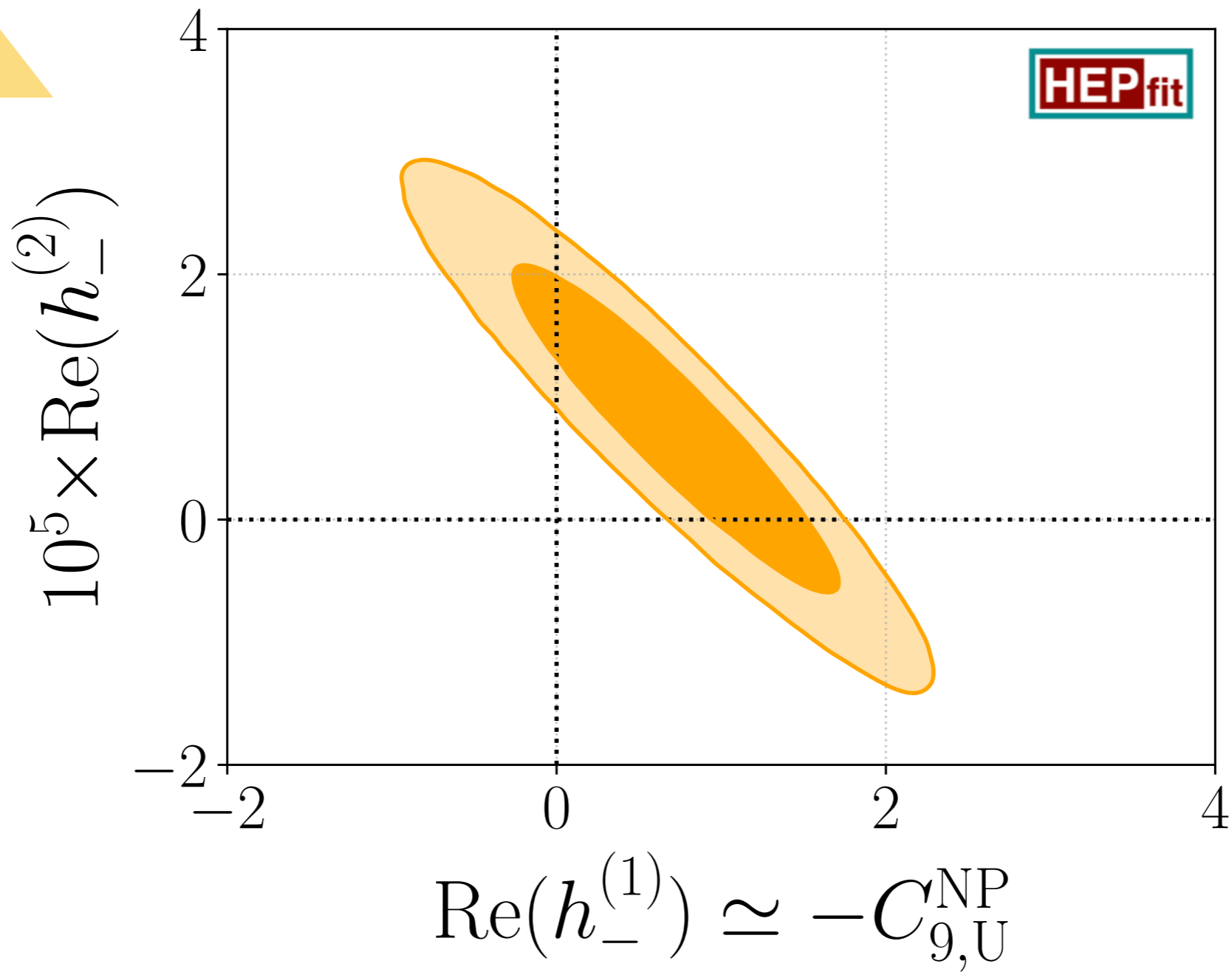

QCD ~ LEPTON UNIVERSAL NP

B ANOMALIES : A FUTURE

See Workshop ANOMALIES 23 @ SCGP

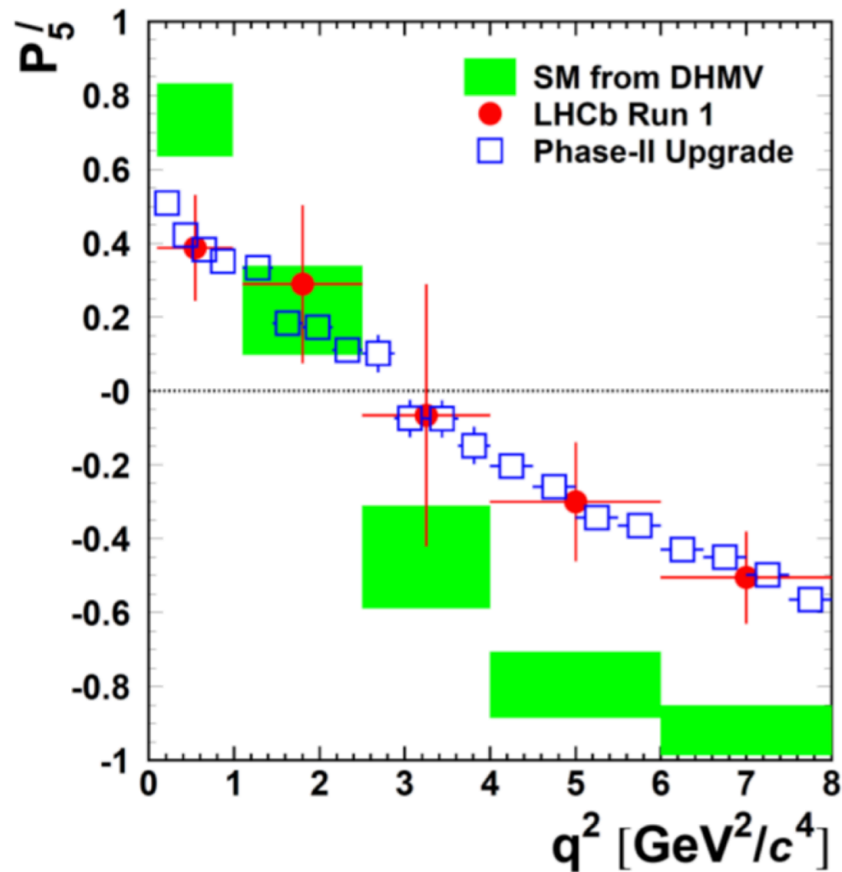

LHCb upgrade(s) will allow us to probe precisely the q^2 dependence in the angular analysis ...

—> *to pin down effects from hadronic physics*

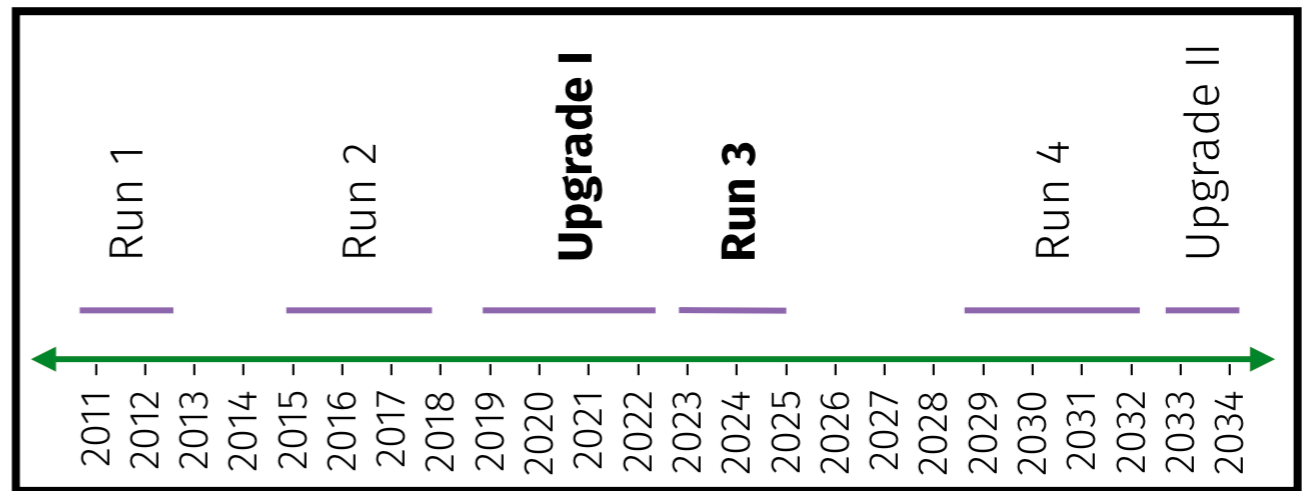

Belle II could also discover New Physics!!!

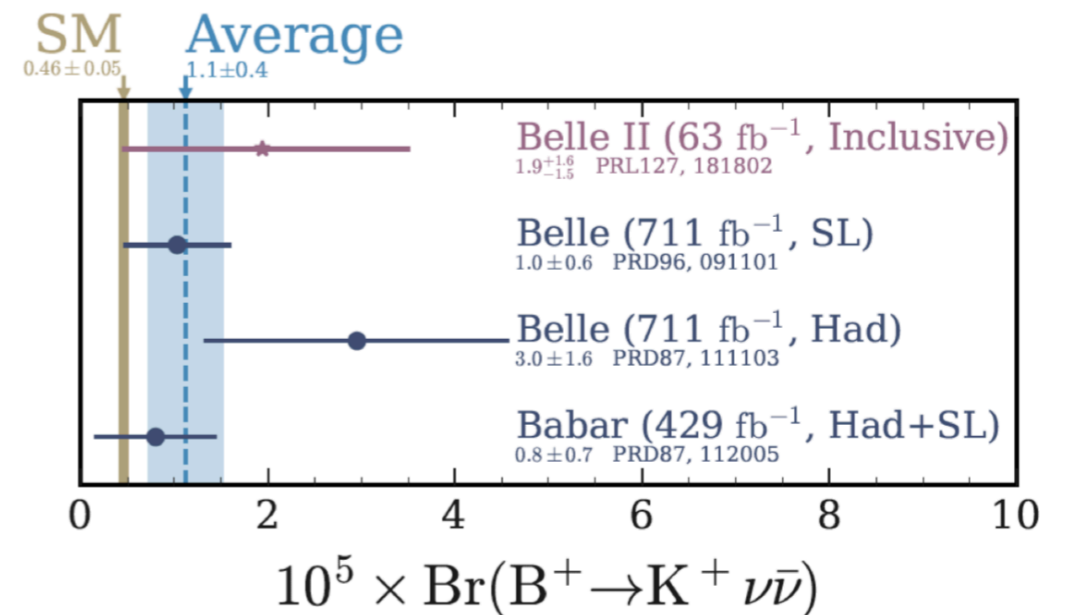
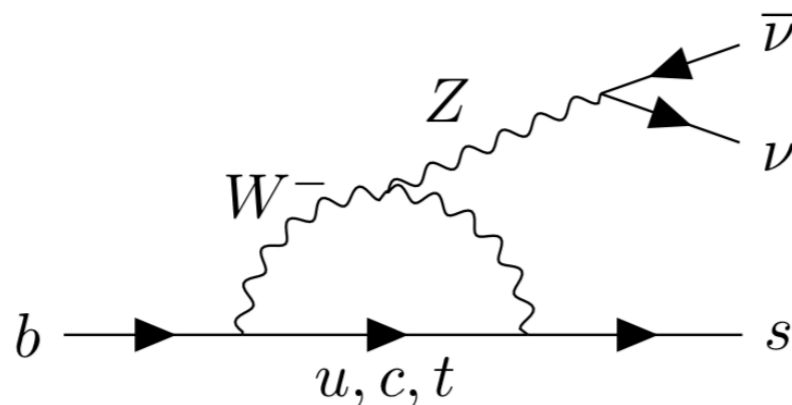



B ANOMALIES: NOT JUST A FCNC PUZZLE

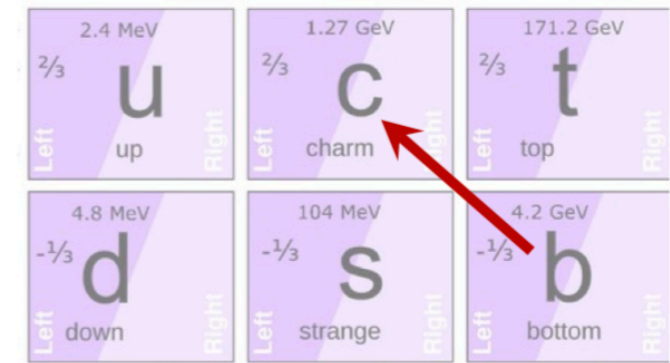
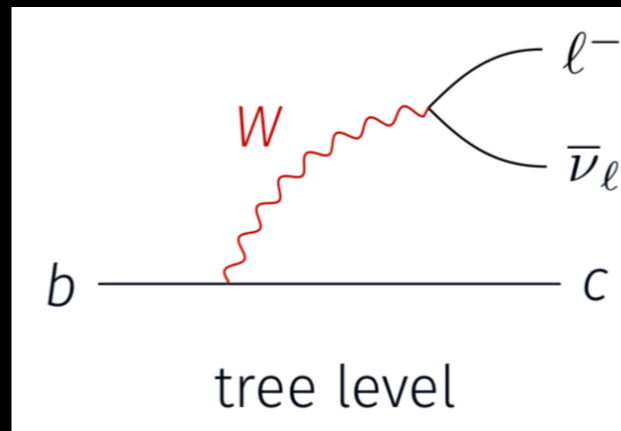

$R(D^*)$ with hadronic τ decays

NEW!

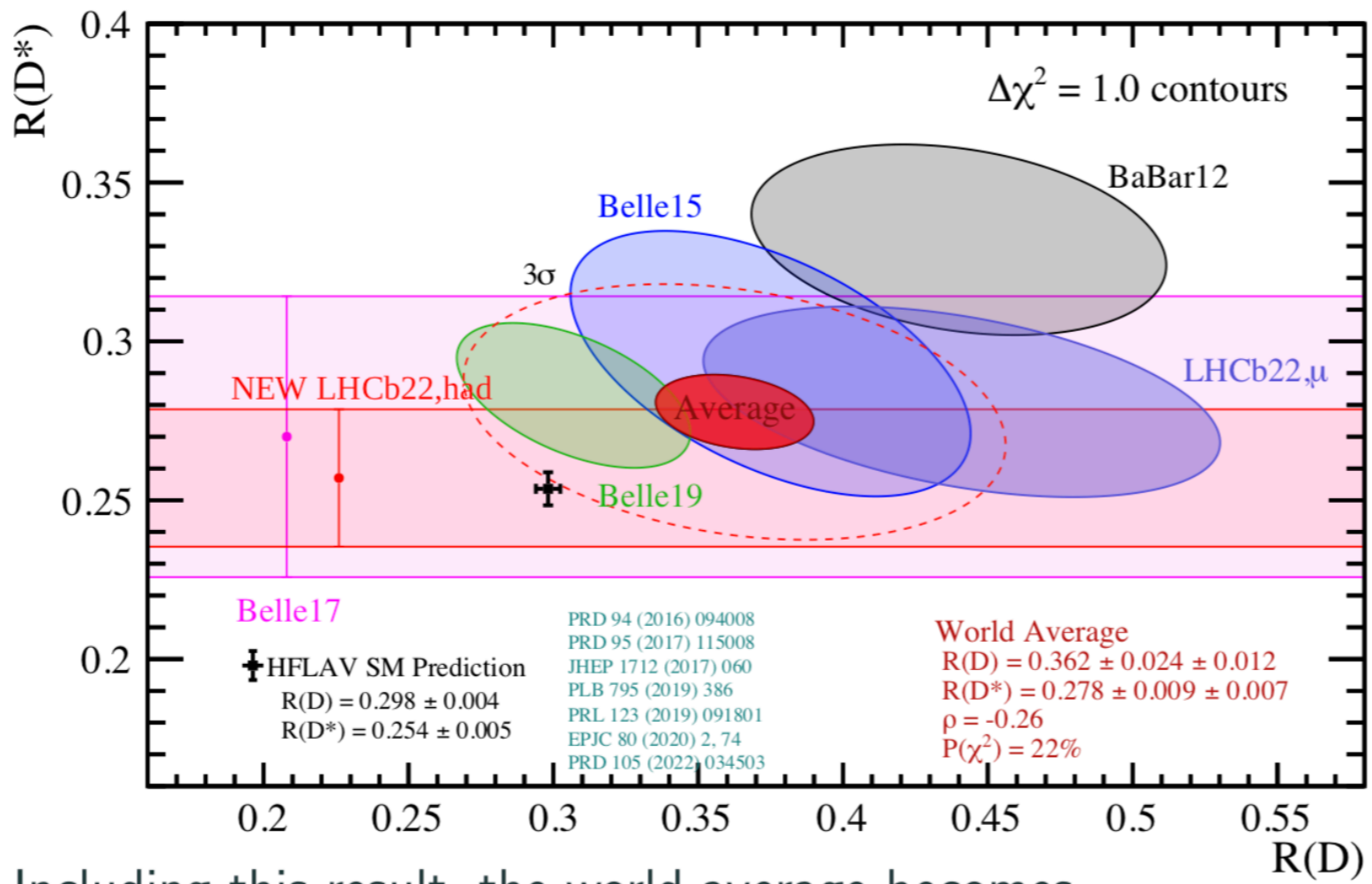

**HFLAV
PRELIMINARY**

[LHCb-PAPER-2022-052]
(In preparation)

- Including this result, the world average becomes
 $R(D^*) = 0.278 \pm 0.011$; $R(D) = 0.362 \pm 0.027$
- The deviation w.r.t. the SM stays at **3.0 σ** level for the combination of $R(D)$ - $R(D^*)$

B ANOMALIES : CIRCA 2023

https://thesis.library.caltech.edu/14598/1/Yunxuan_Li_2022_thesis.pdf

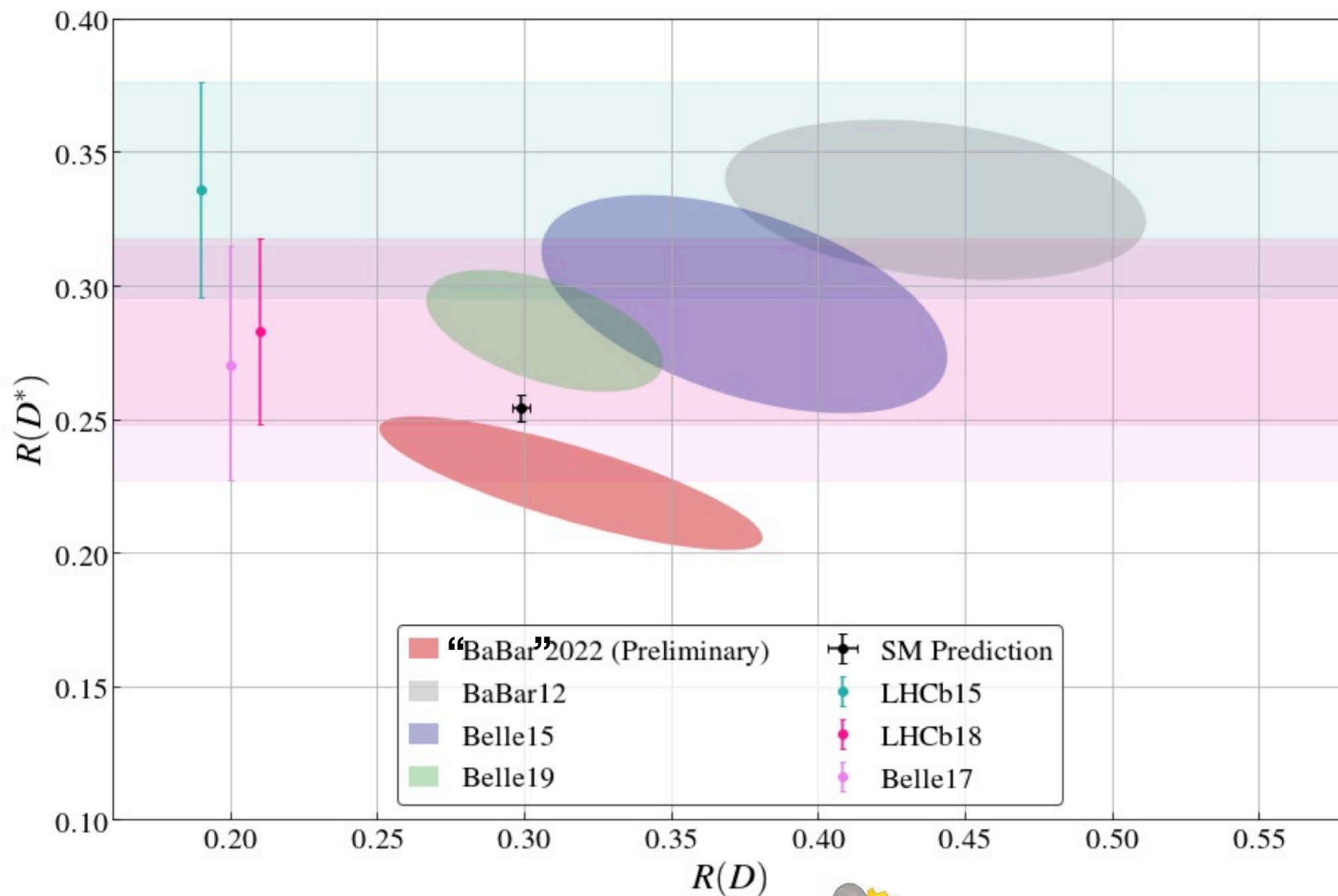

Waitin' for ~~Godot~~



...



Take Home

For most of 2022, NP effects were robustly above 5σ ...

Unfortunately, in 2023 data do not longer support this conclusion.

NP cannot be disentangled from hadronic physics.



- *Charming penguins in B decays via FCNCs need **more data***
- ***BaBar crucial x $R_{D^{(*)}}$, maybe the last vestige of LUV in B decays!***
- *Look forward to upgrades @ **LHCb** and to **Belle II***

BACKUP

B ANOMALIES : CIRCA 2023

[2110.10126]

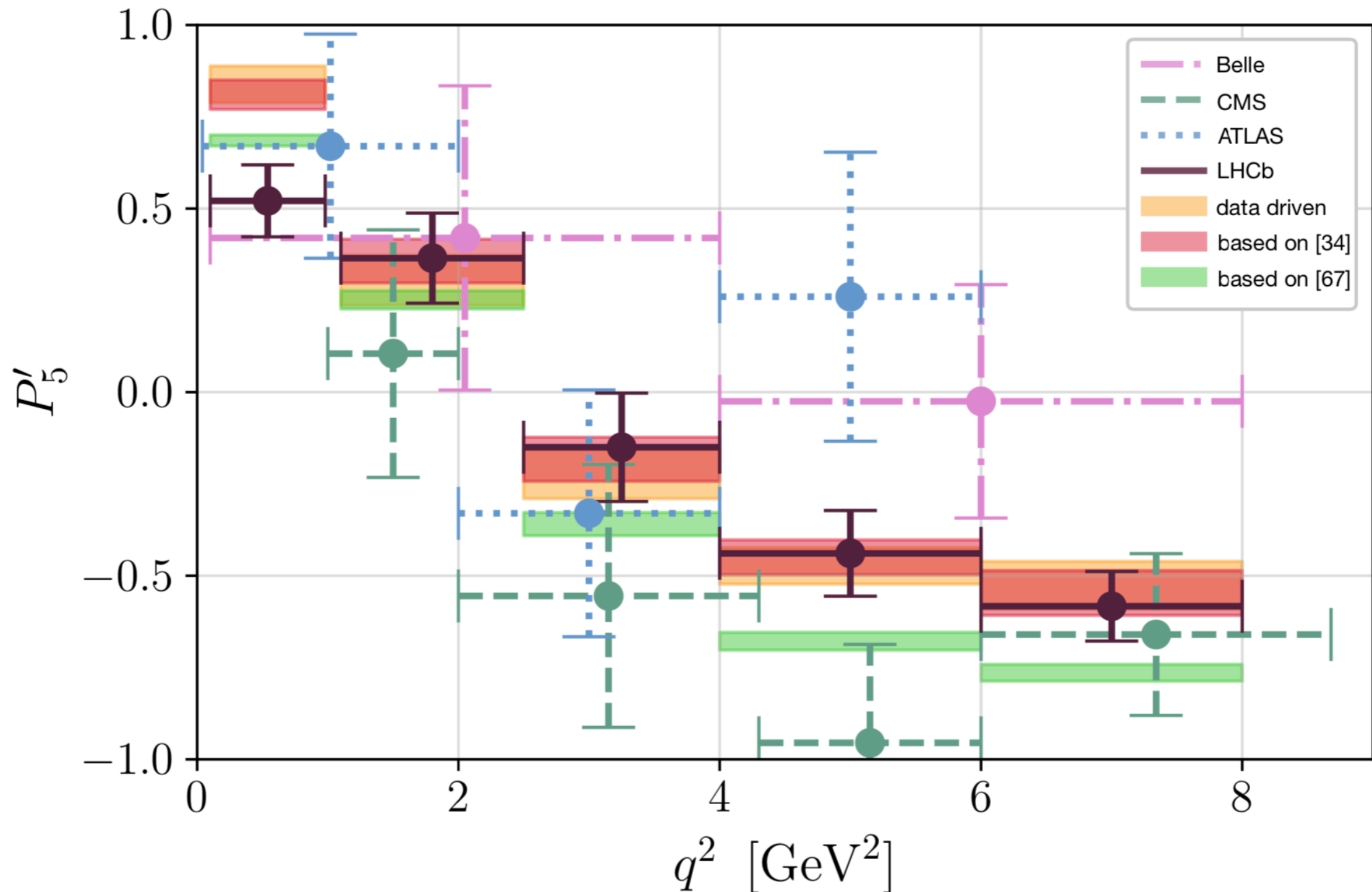

34. M. Ciuchini, A. M. Coutinho, M. Fedele, E. Franco, A. Paul, L. Silvestrini et al., *Hadronic uncertainties in semileptonic $B \rightarrow K^* \mu^+ \mu^-$ decays*, *PoS BEAUTY2018* (2018) 044, [[arXiv:1809.03789](https://arxiv.org/abs/1809.03789)].

67. A. Khodjamirian, T. Mannel, A. Pivovarov and Y.-M. Wang, *Charm-loop effect in $B \rightarrow K^{(*)} \ell^+ \ell^-$ and $B \rightarrow K^* \gamma$* , *JHEP* **09** (2010) 089, [[arXiv:1006.4945](https://arxiv.org/abs/1006.4945)].

B ANOMALIES : CIRCA 2023

[2110.10126]

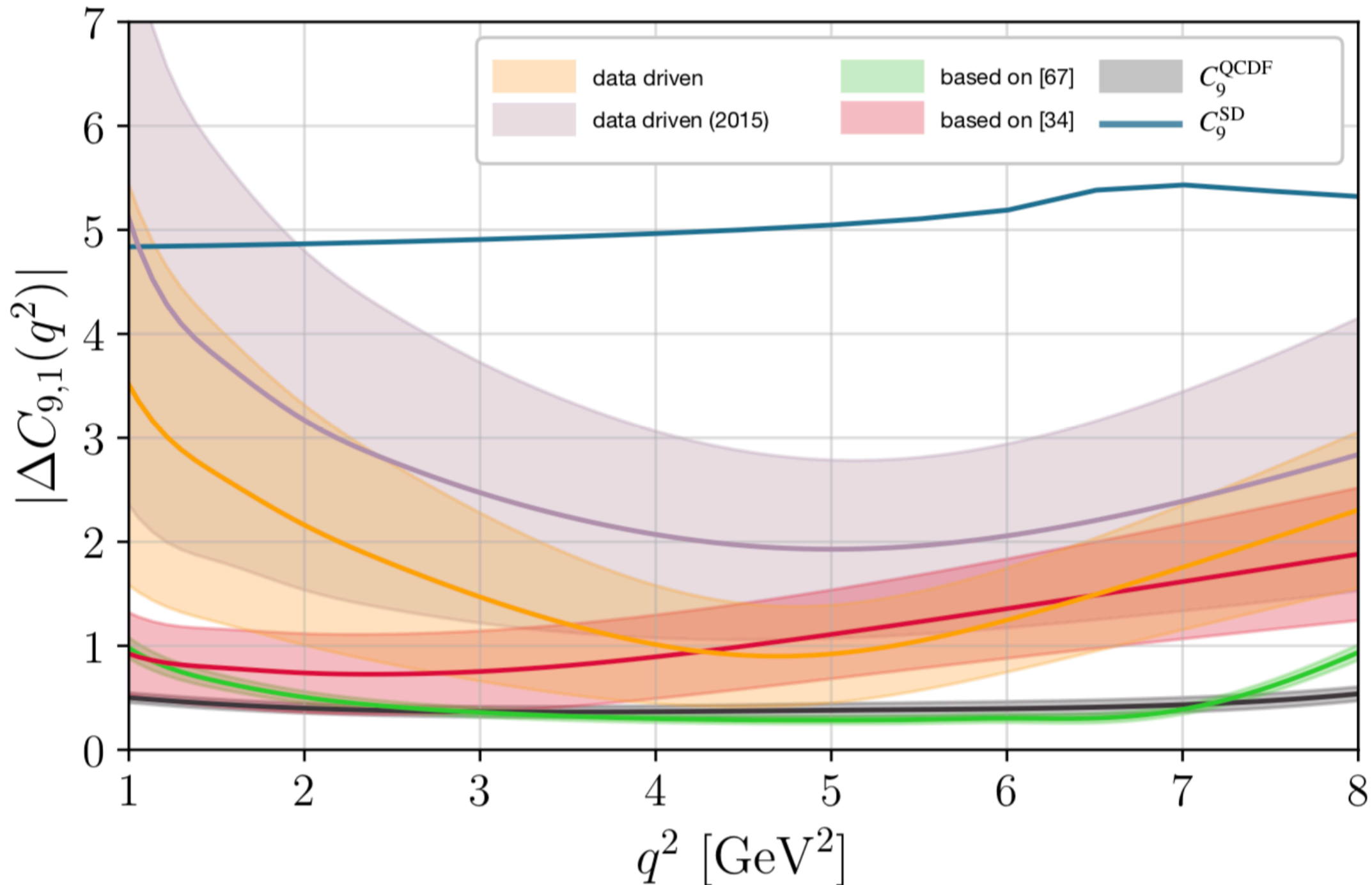

34. M. Ciuchini, A. M. Coutinho, M. Fedele, E. Franco, A. Paul, L. Silvestrini et al., *Hadronic uncertainties in semileptonic $B \rightarrow K^* \mu^+ \mu^-$ decays*, *PoS BEAUTY2018* (2018) 044, [[arXiv:1809.03789](https://arxiv.org/abs/1809.03789)].

67. A. Khodjamirian, T. Mannel, A. Pivovarov and Y.-M. Wang, *Charm-loop effect in $B \rightarrow K^{(*)} \ell^+ \ell^-$ and $B \rightarrow K^* \gamma$* , *JHEP* **09** (2010) 089, [[arXiv:1006.4945](https://arxiv.org/abs/1006.4945)].

KNOWN UNKNOWN IN $B \rightarrow K^* \ell \bar{\ell}$

Phenomenological
Data Driven (PDD)

$$\tilde{h}_\lambda(q^2) = \sum_k \tilde{h}_\lambda^{(k)} \left(\frac{q^2}{\text{GeV}^2} \right)^k \quad \text{up to } k=2, \text{ 16 real coeffs involved}$$

ΔC_9 (semi-lep operator)

ΔC_7 (e.m. dipole operator)

$$\left\{ (C_9^{\text{eff}} + h_-^1) V_{L-} + \frac{m_B^2}{q^2} \left[\frac{2m_b}{m_B} (C_7^{\text{eff}} + h_-^0) T_{L-} - 16\pi^2 h_-^2 q^4 \right] \right\}$$

$$\left\{ (C_9^{\text{eff}} + h_-^1) \tilde{V}_{L0} + \frac{m_B^2}{q^2} \left[\frac{2m_b}{m_B} (C_7^{\text{eff}} + h_-^0) \tilde{T}_{L0} - 16\pi^2 (\tilde{h}_0^0 + \tilde{h}_0^1 q^2) \right] \right\}$$

$$\left\{ (C_9^{\text{eff}} + h_-^1) V_{L+} + \frac{m_B^2}{q^2} \left[\frac{2m_b}{m_B} (C_7^{\text{eff}} + h_-^0) T_{L+} - 16\pi^2 (h_+^0 + h_+^1 q^2 + h_+^2 q^4) \right] \right\}$$

DO NOT HAVE $C_{7,9}$ SHORT-DISTANCE COUNTERPART!

“CONSERVATIVE” APPROACH = TRUST LCSR RESULTS **ONLY** AT $q^2 \leq \text{GeV}^2$.

REQUIRE ALSO $|h_+/h_-| \ll 1$ AT LARGE RECOIL (Jager & Camalich`14).

Phenomenological Data Driven

$$h_{0,\pm}(q^2) = \sum_{k=0,1,2} h_{0,\pm}^{(k)} \left(\frac{q^2}{\text{GeV}^2} \right)^k$$

PROJECTIONS @ 50 fb⁻¹

(Hurth et al. '17 + Albrecht et al. '17)



Scaling LHCb stat errors roughly of 1/6

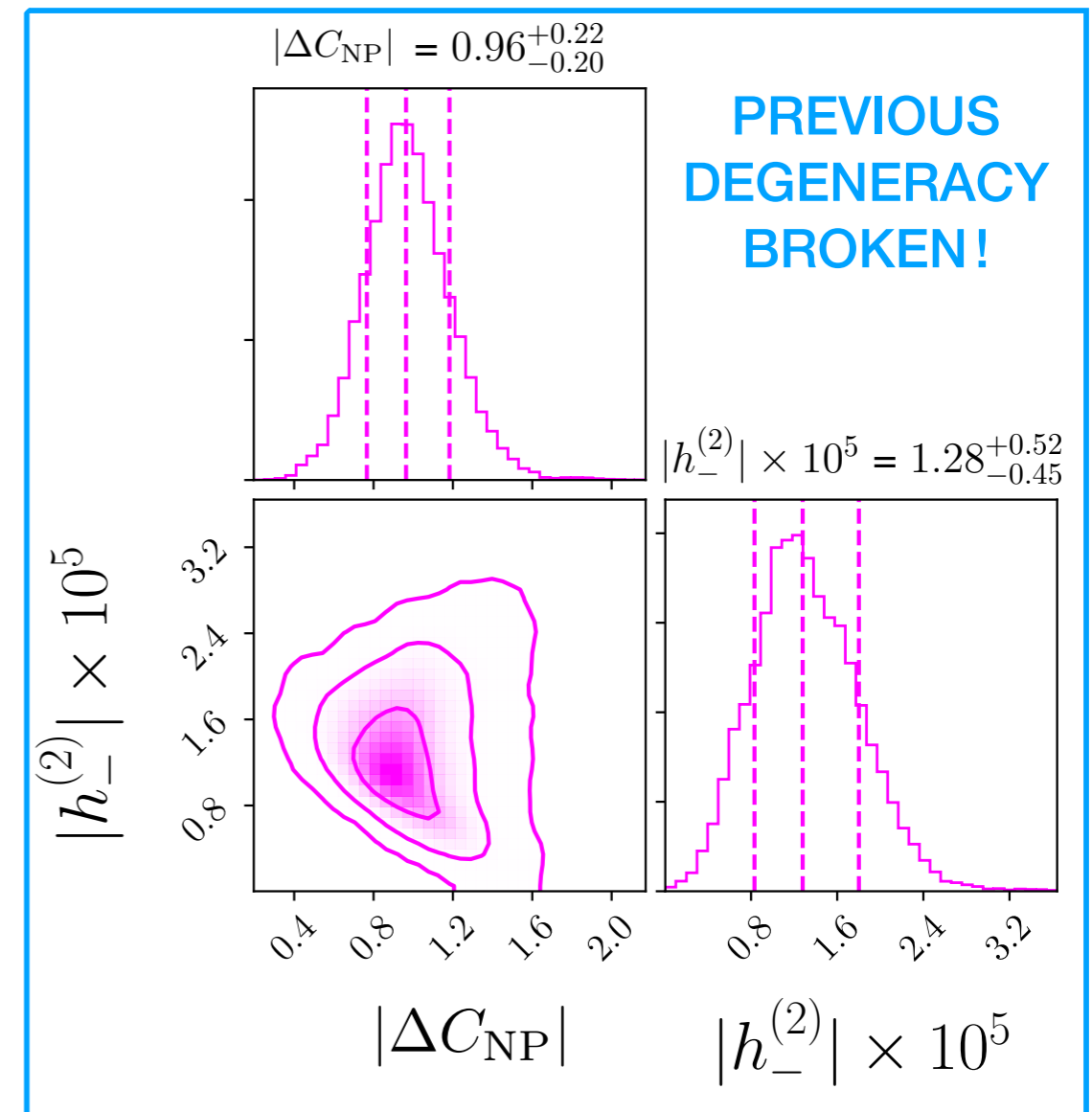
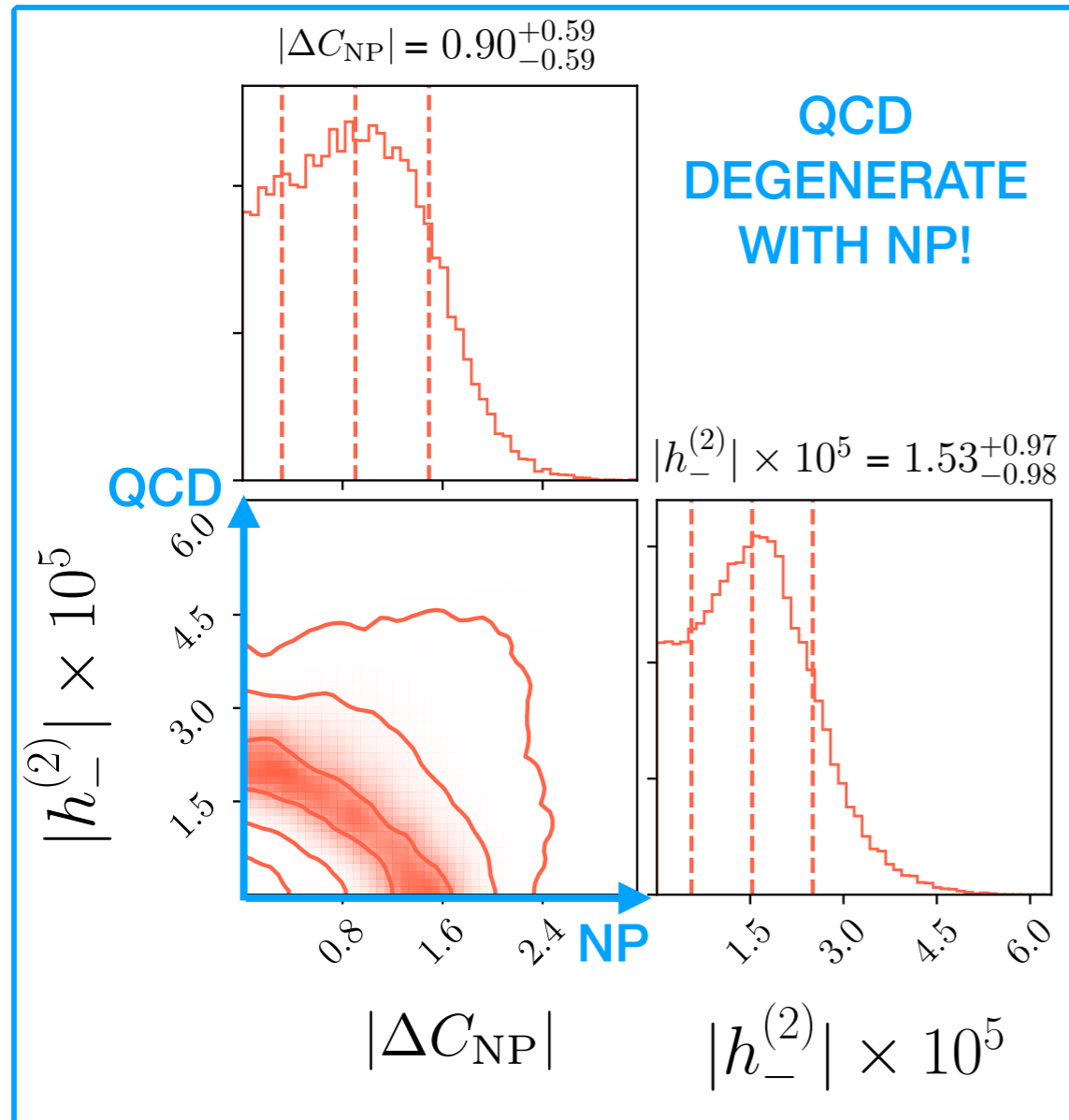

[**1809.03789**]

- What is the scale of New Physics?

$$\Lambda_{R_{D^{(*)}}} = 3.4 \pm 0.4 \text{ TeV},$$

$$\Lambda_{R_{K^{(*)}}} = 31 \pm 4 \text{ TeV},$$

"Measured"
Fermi constant

$$\frac{1}{\Lambda^2} = \frac{C}{M^2}$$

Model dependent part

$C = (\text{loops}) \times (\text{couplings}) \times (\text{flavour})$

On-shell effects @ colliders

- What do we expect? (**Worst case scenario**)

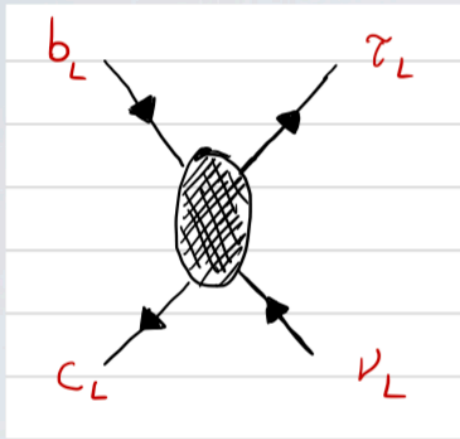

$$\mathcal{A}(\psi\psi \rightarrow \psi\psi) \propto s$$

Tree-Level Perturbative
Unitarity criterium

$$|\mathcal{A}_{J=0}| < 1/2$$

$$\begin{cases} \sqrt{s}_{max} \equiv \Lambda_U = 9 \text{ TeV} & b \rightarrow c\tau\nu \\ \sqrt{s}_{max} \equiv \Lambda_U = 80 \text{ TeV} & b \rightarrow s\mu\mu \end{cases}$$

[Di Luzio, MN, 1706.01868]

An old lesson: VV scattering...
 $\Lambda_U = 2 \text{ TeV}, m_h = 125 \text{ GeV}$

- What do we expect? (**Warning**: a simplified cartoon!)

$$b \rightarrow c\tau\nu$$

$$b \rightarrow s\mu\mu$$

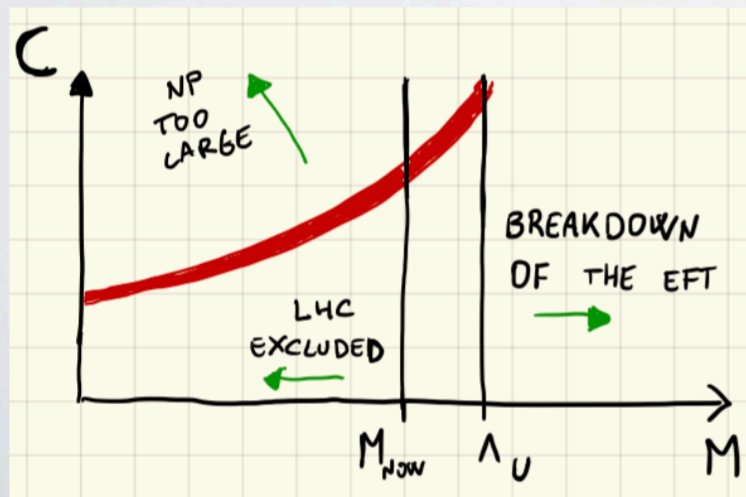

Absence of New Physics
at high energy

$$M_{now} \gtrsim 1 \text{ TeV}$$

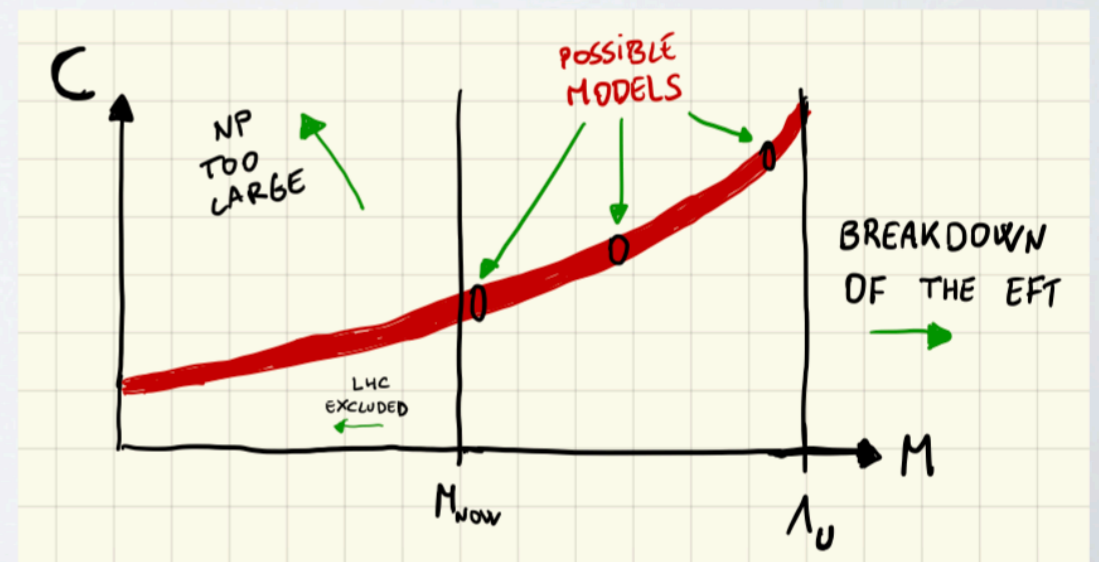

BASIC OPTIONS FOR B ANOMALIES

$\Delta F = 1$ @ Tree

$\Lambda_{\text{NP}} \sim 30 \text{ TeV}$

for $\mathcal{O}(1)$ couplings

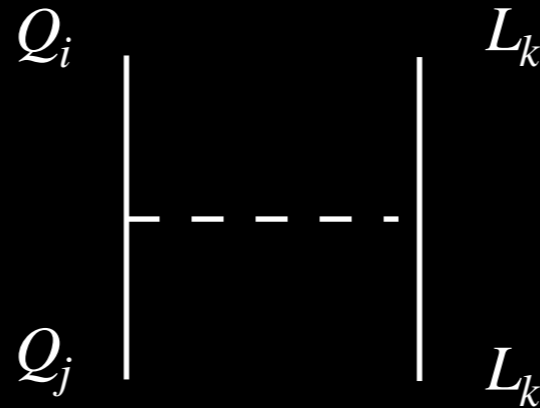

Z'-like
[...]

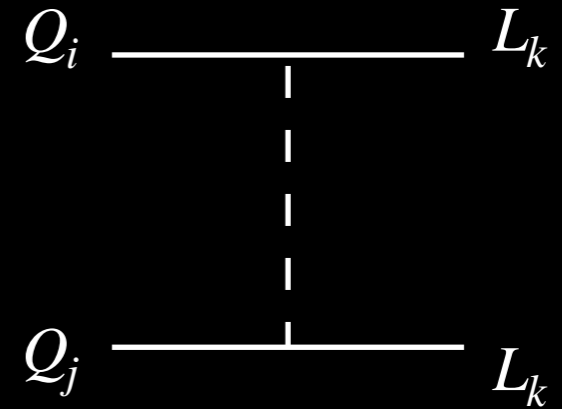

Leptoquark-like
[.....]

$\Delta F = 1$ @ Loop

$\Lambda_{\text{NP}} \sim \text{few TeV}$

for $\mathcal{O}(1)$ couplings

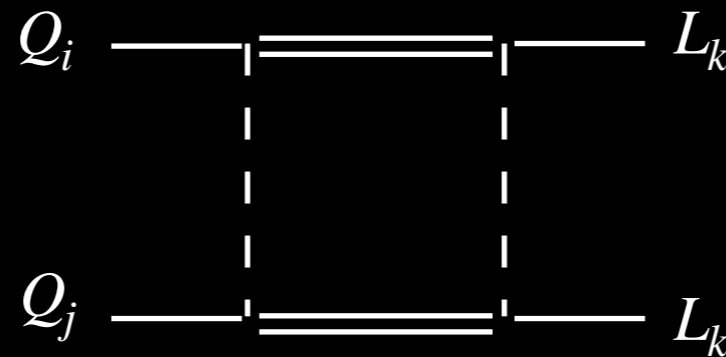

(R-conserving)
SUSY-like

[1308.1501,
1704.05438]

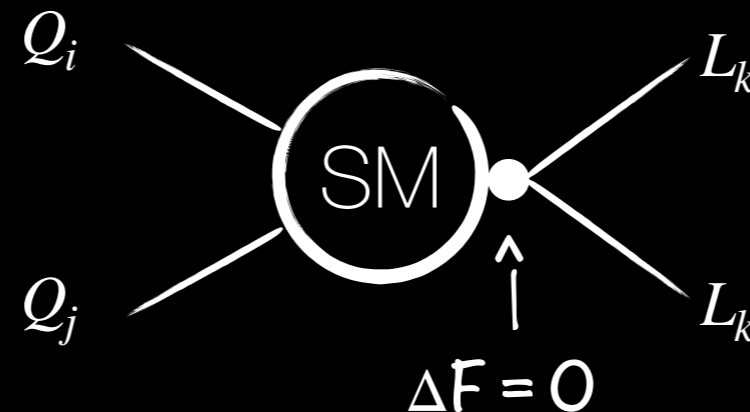

Minimal Flavor Violation
(MFV) - like

[1704.05672,
1704.06005]