

E300 Collaboration Meeting - TCAV, LPS real and virtual in 2022/2023

Claudio Emma

October 5, 2022, UCLA

E327 - Virtual LPS diagnostic high level goals

C. Emma, A. Edelen et al., PRAB 21 112802 (2018)

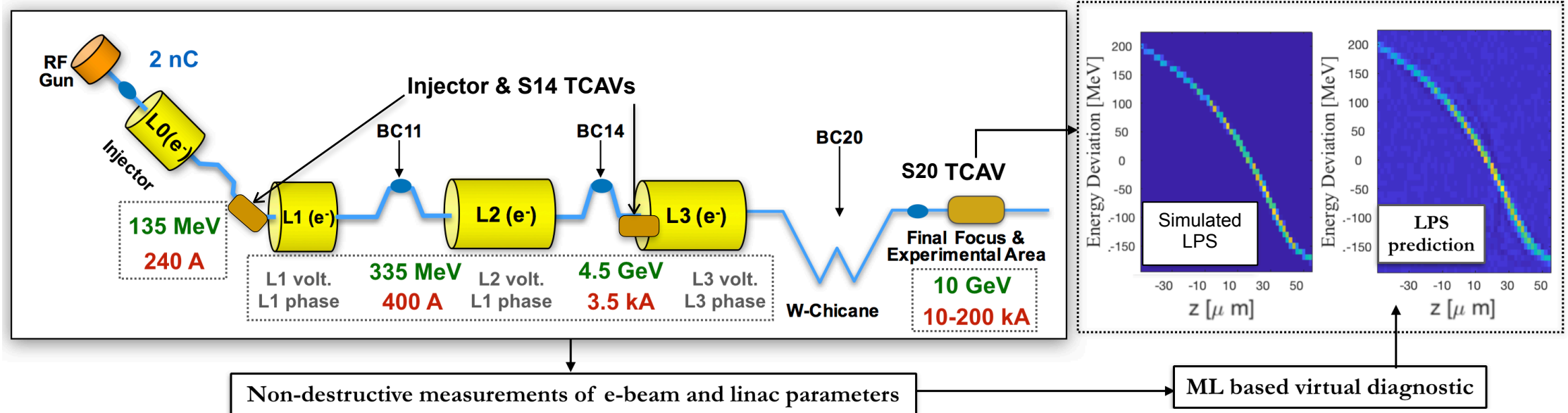

1. Implement a single-shot non-destructive ML diagnostic to predict the e-beam LPS along the linac.
2. Use the ML-diagnostic to customize/control the LPS for different experiments.

TCAV shifts - timeline and synopsis

- How many shifts did we take? When did we take beam and what did we do in each shift?
- What diagnostics did we record data on to correlate with TCAV measurements?

Shift Summary Date	Experiment Num	Shift Start Time	Shift End Time	Charge in S20	Useful Beam Time	Accelerator Downtime	User Downtime	Brief Summary
12/17/21	E327	12/16/21 20:13	12/17/21 8:13	350 pC	12	0	0	TCAV measurements scanning L2 phase data gathered. Inj opt data gathered with match
7/8/22	E300	7/8/22 16:35	7/8/22 18:15	750 pC	2	0	0	Scan L2 phase and measure the LPS using the XTCAV at each bunch length through full compression. Record SYAG, TCAV screen and upstream scalars to correlate later
7/12/22	E300	7/12/22 12:00	7/12/22 15:30	720 pC	3.5	0	0	Record laser/e-beam TOA data with EOS simultaneously with TCAV TOA data. Record of EOS-BPM signal response to transverse motion of e-beam orbit in vicinity of EO crystals.
7/31/22	E325	7/30/22 15:00	7/31/22 2:00	1.6 nC	11	0	0	Scan machine parameters while observing longitudinal phase space properties with TCAV, EOS, and COTR signals. Sub-goal: repeat injector scans.
8/22/22	E331	8/21/22 14:30	8/22/22 2:30	1.6 nC	6	6	0	Ran Bayesian Optimization on Sextupole movers. Gathered TCAV, EOS and wire scanner data at different sextupole mover positions
				Sum Total Hrs	34.5	6	0	

TCAV data from L2 phase scans 12/17/21- long bunch, 350 pC

Example raw images
with horizontal
projections

Cal = 12.1 $\mu\text{m}/\text{pix}$

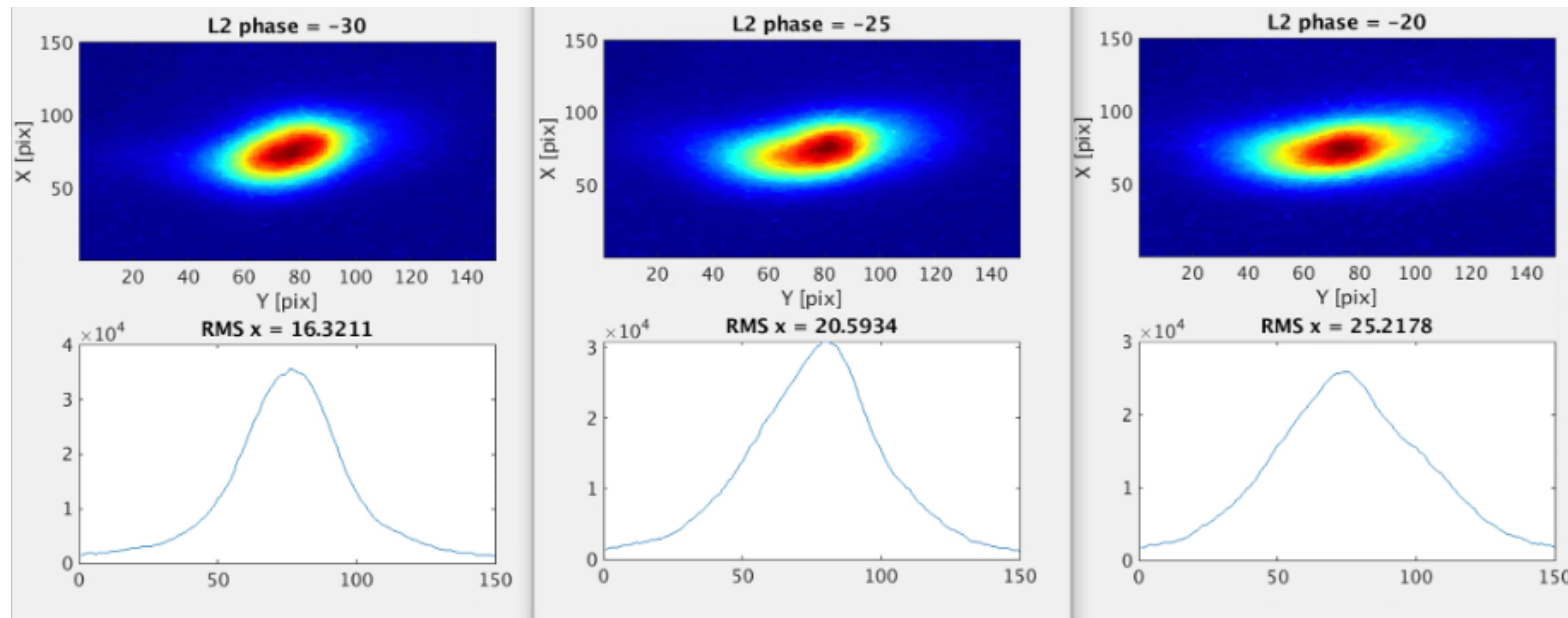

RMS spot size on
PRDMP vs L2 phase
with TCAV on

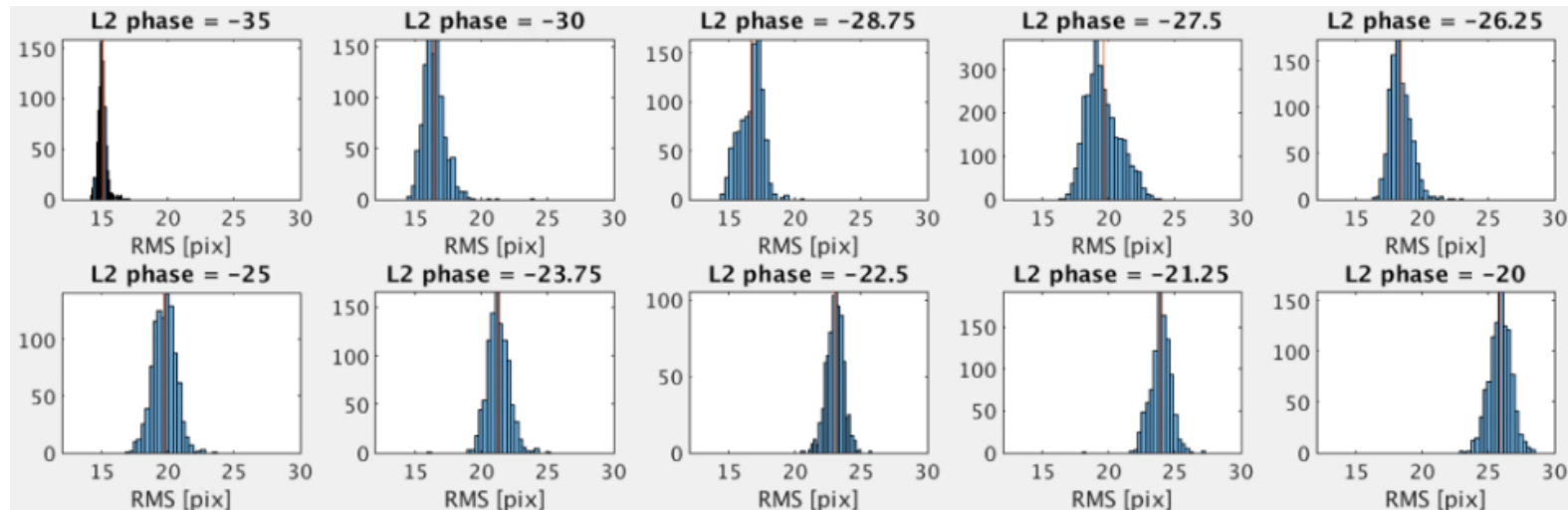

TCAV data from L2 phase scans 12/17/21 - ML predictions

Mean charge at Injector 'TORO_IN10_431_0_TMIT' = 470 pC
Mean charge in S20 'TORO_LI20_3163_0_TMIT' = 360 pC

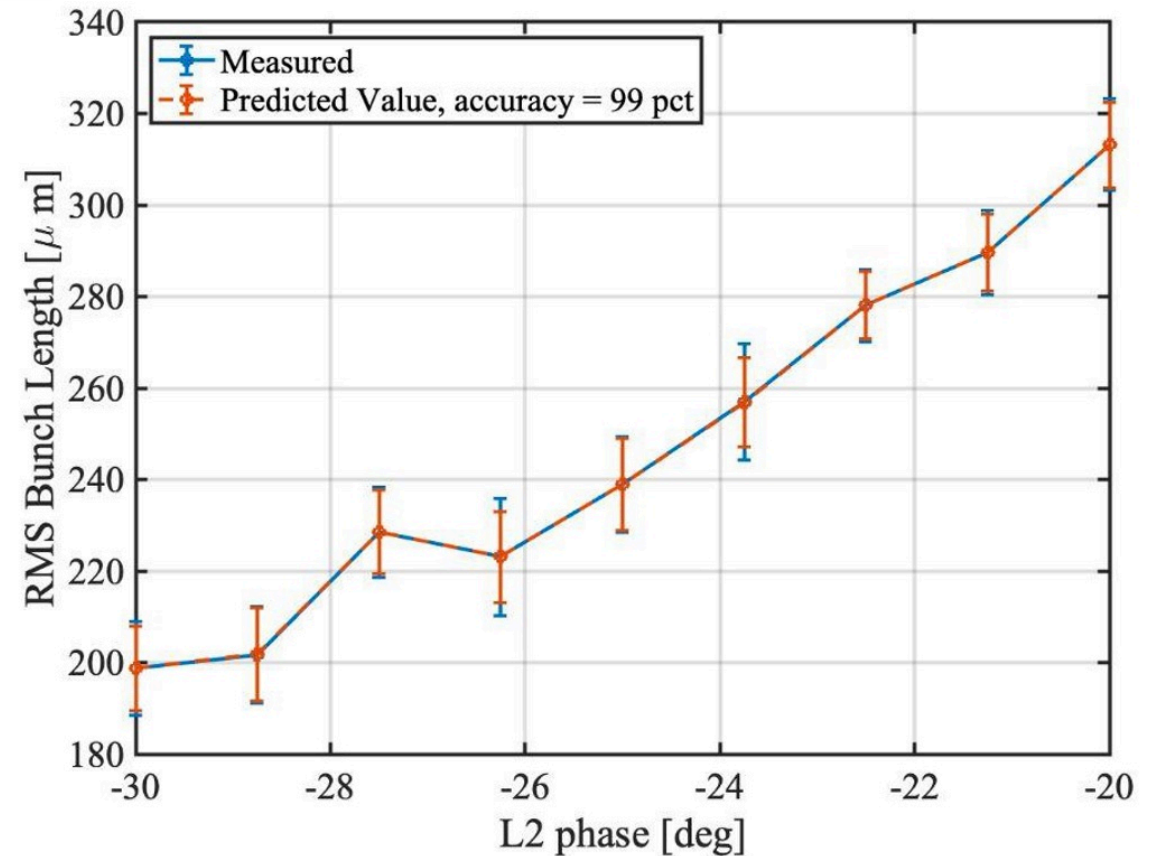
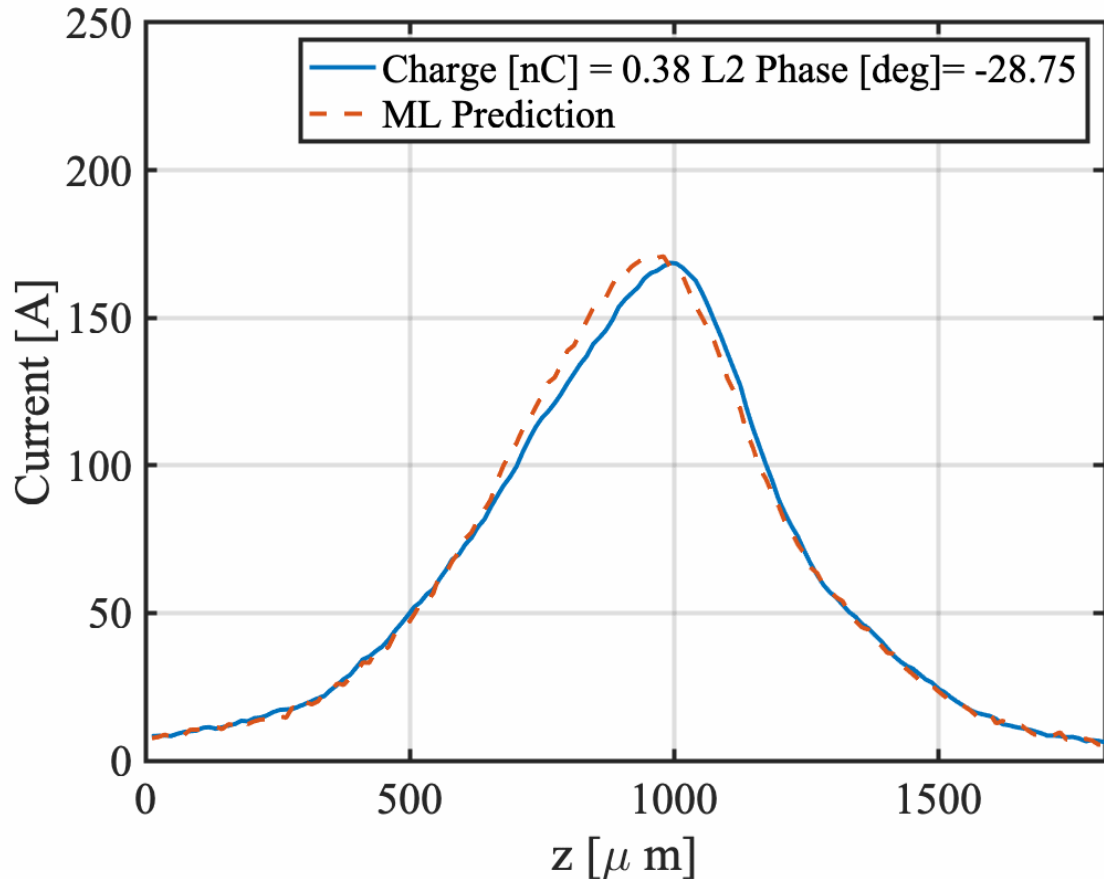

At low charge/long bunch length, ML model accurately predicts changes in bunch length

TCAV images from L2 phase scan through full compression 750 pC 7/8/22

Region thought to be around full compression

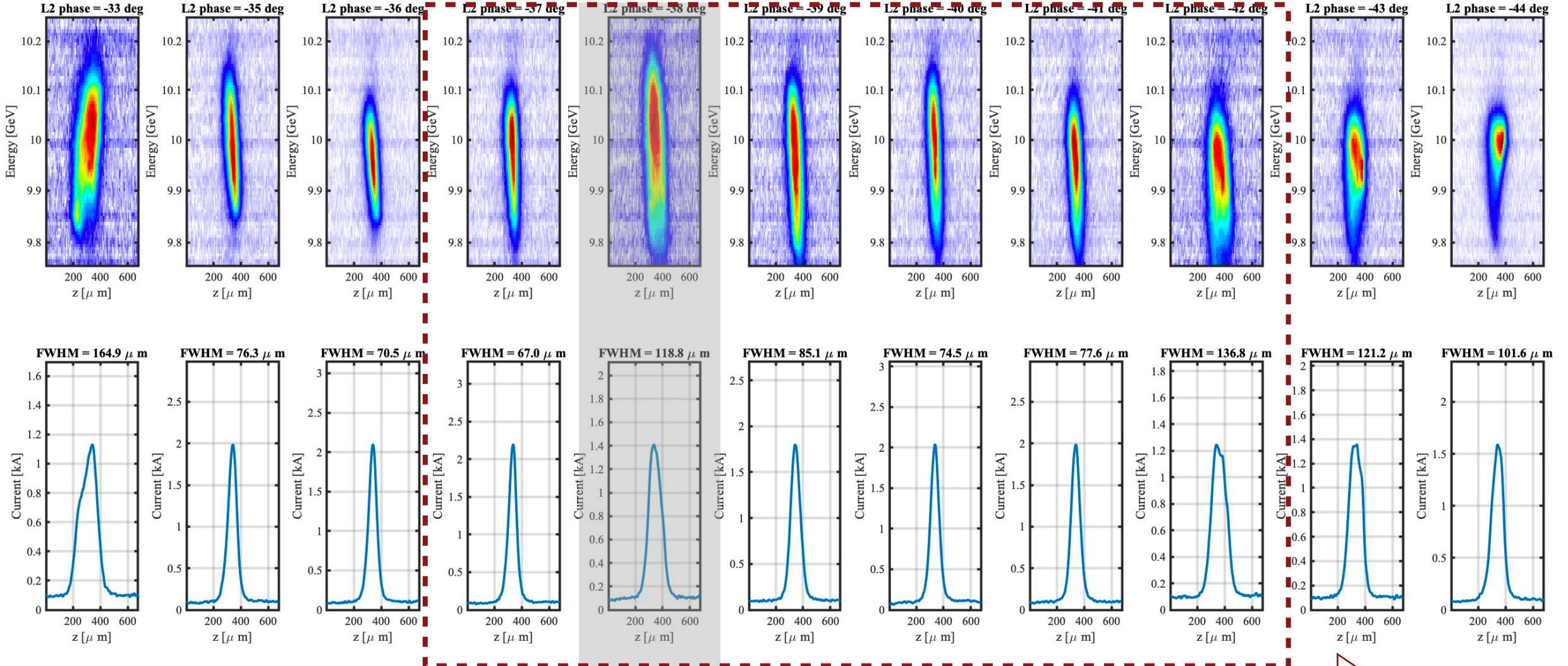

TCAV images from L2 phase scans through full compression at 750 pC - 7/8/22

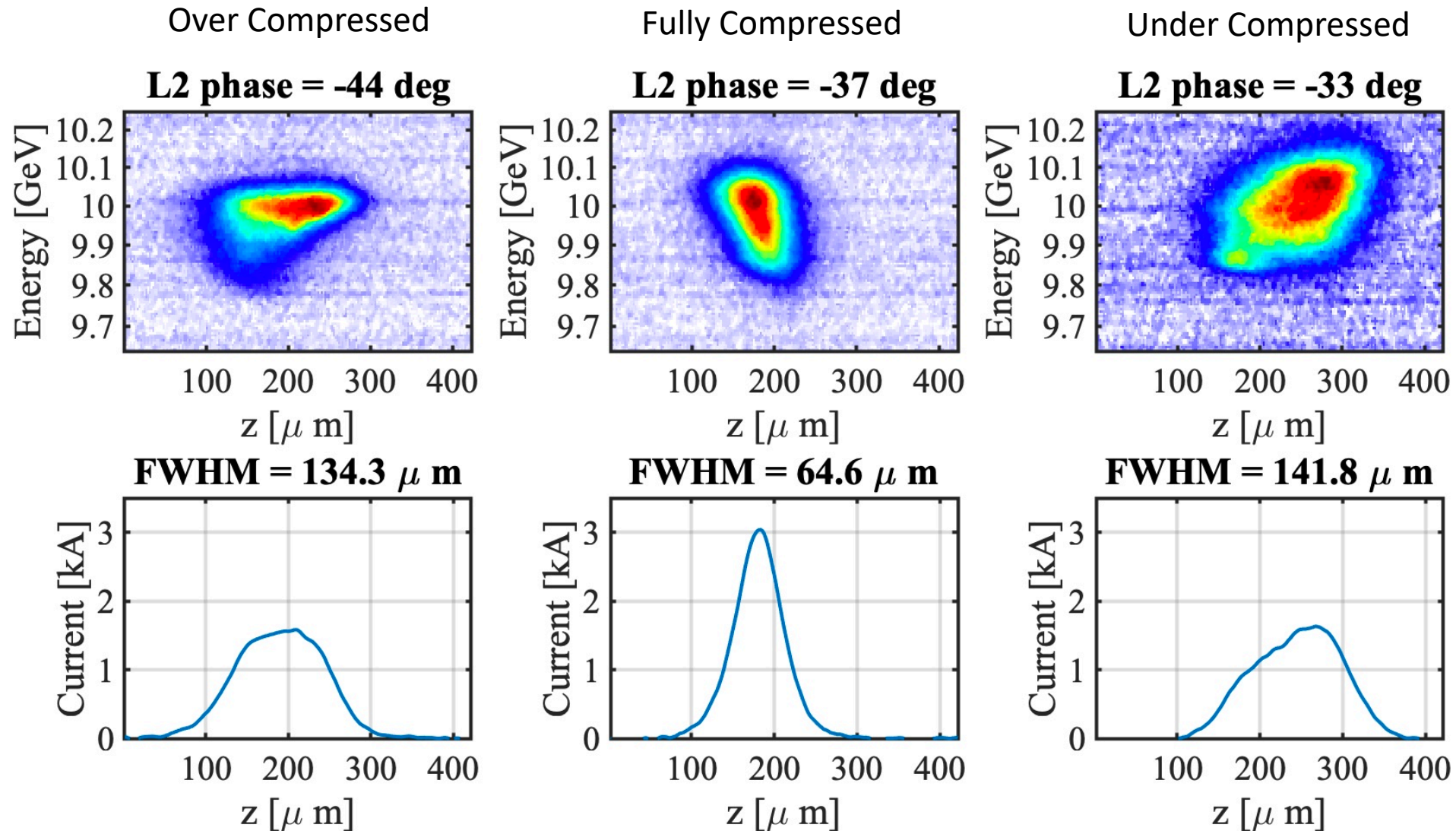

TCAV data from L2 phase scans through full compression at 750 pC - 7/8/22

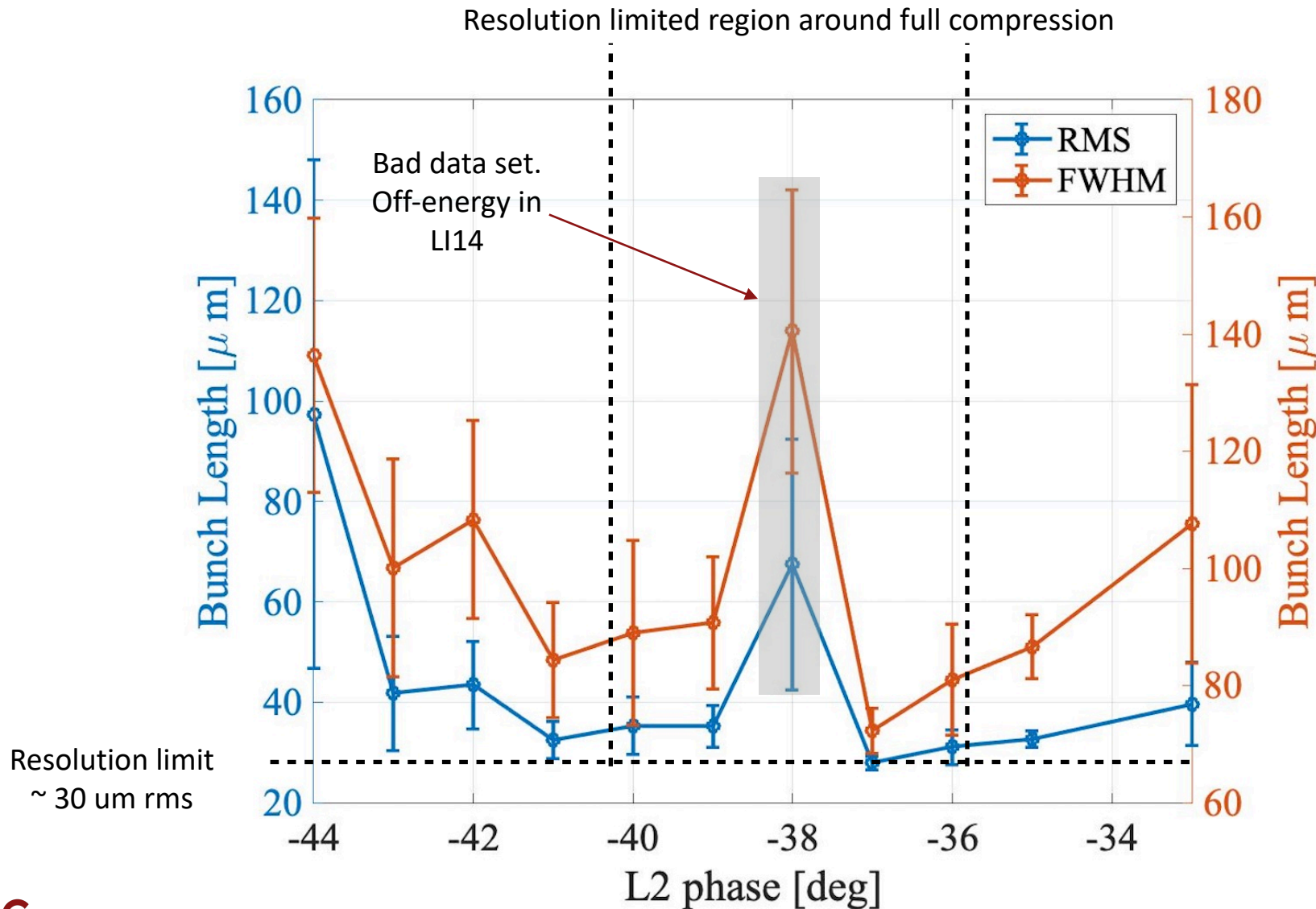

Emittance measurements before our shift - L2 emittance at WS11444

nemitX = 7.4 mm-mrad
 nemitX*bmag = 15.5 mm-mrad

nemitY = 9.1 mm-mrad
 nemitY*bmag = 22.3 mm-mrad

Unstreaked spot size on DTOTR2 for these measurements
 (smallest visible bunch length)
 ~ 500 um in x i.e. ~ 30 um in z
 (after calibration)

Correlation with SYAG from L2 phase scans through full compression at 750 pC - 7/8/22

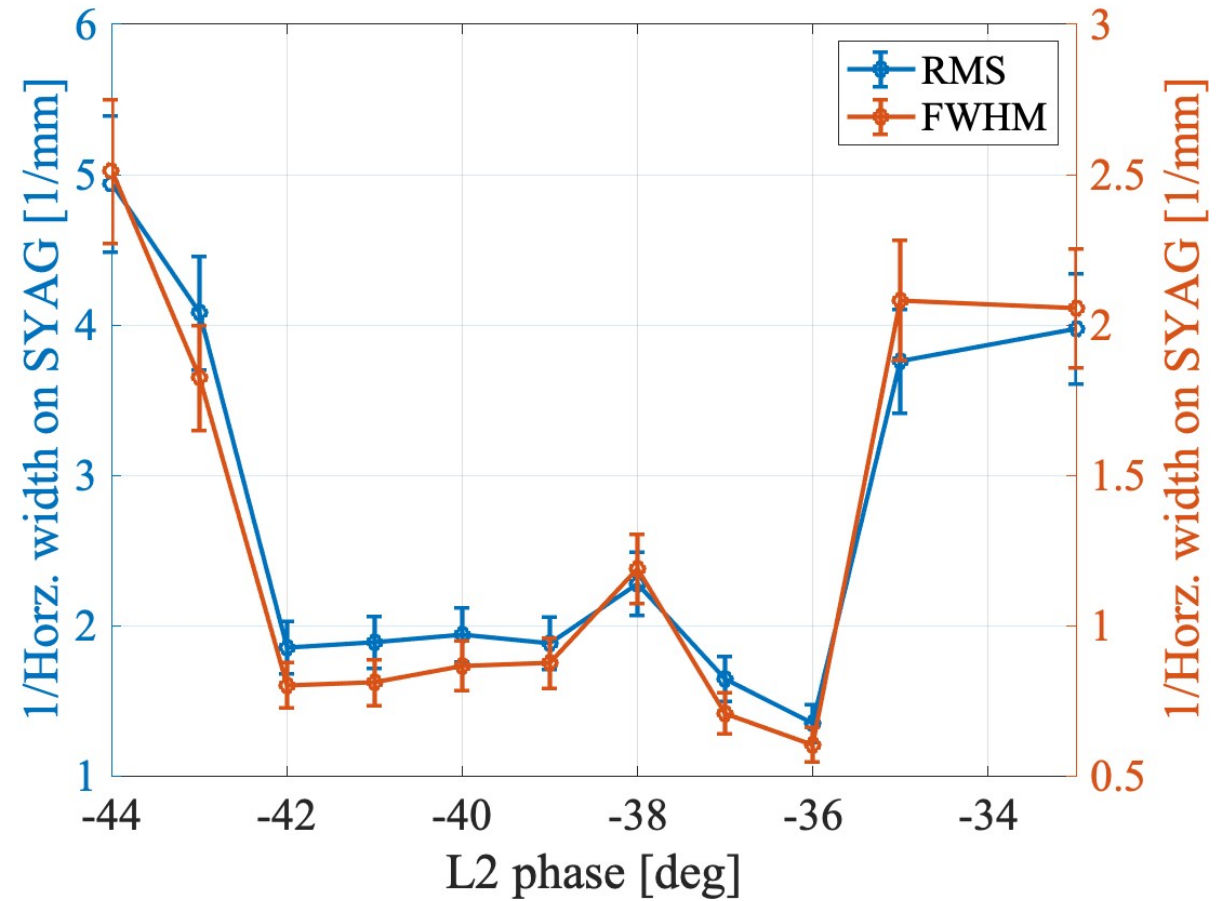
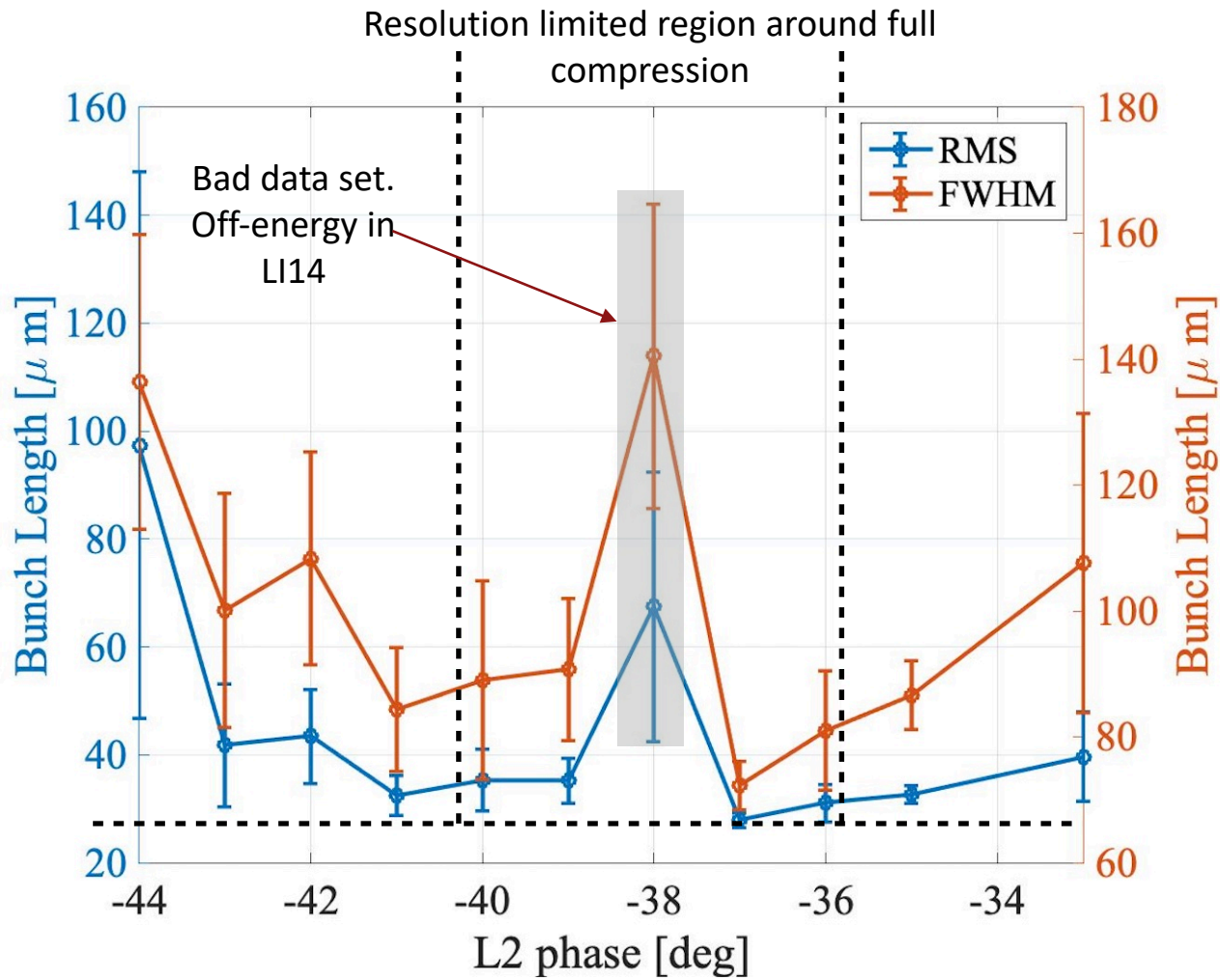

Evidence of microbunching on TCAV - data from 7/12/22

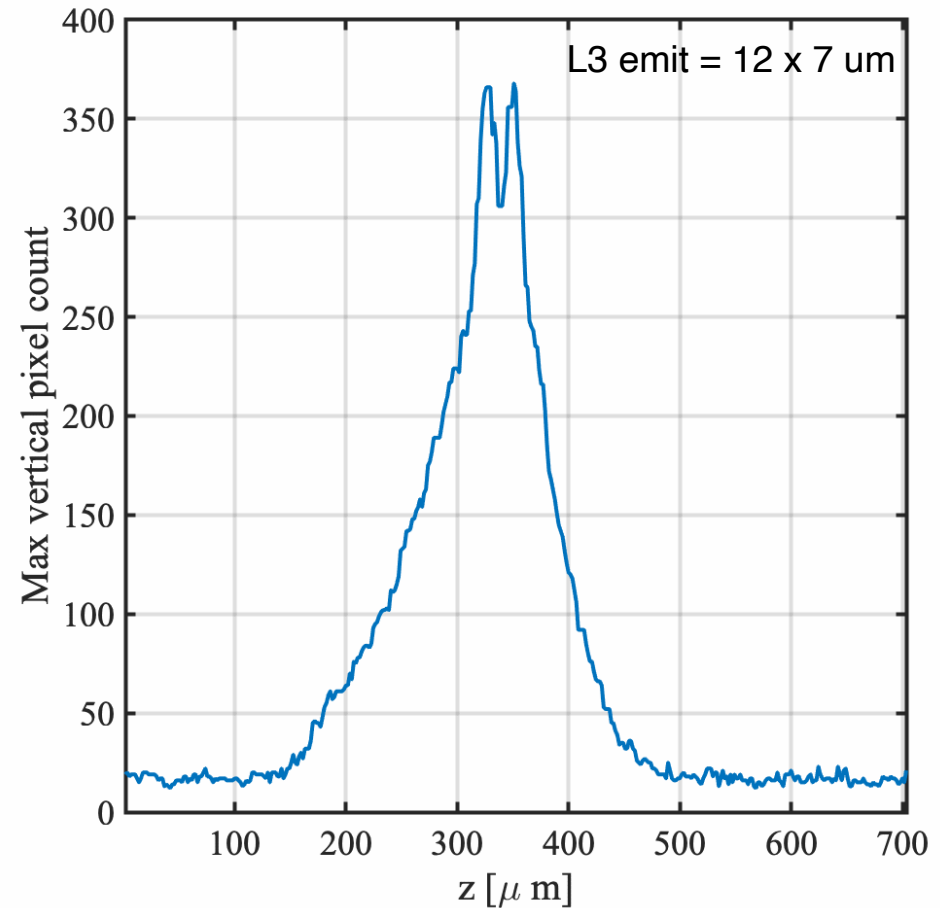
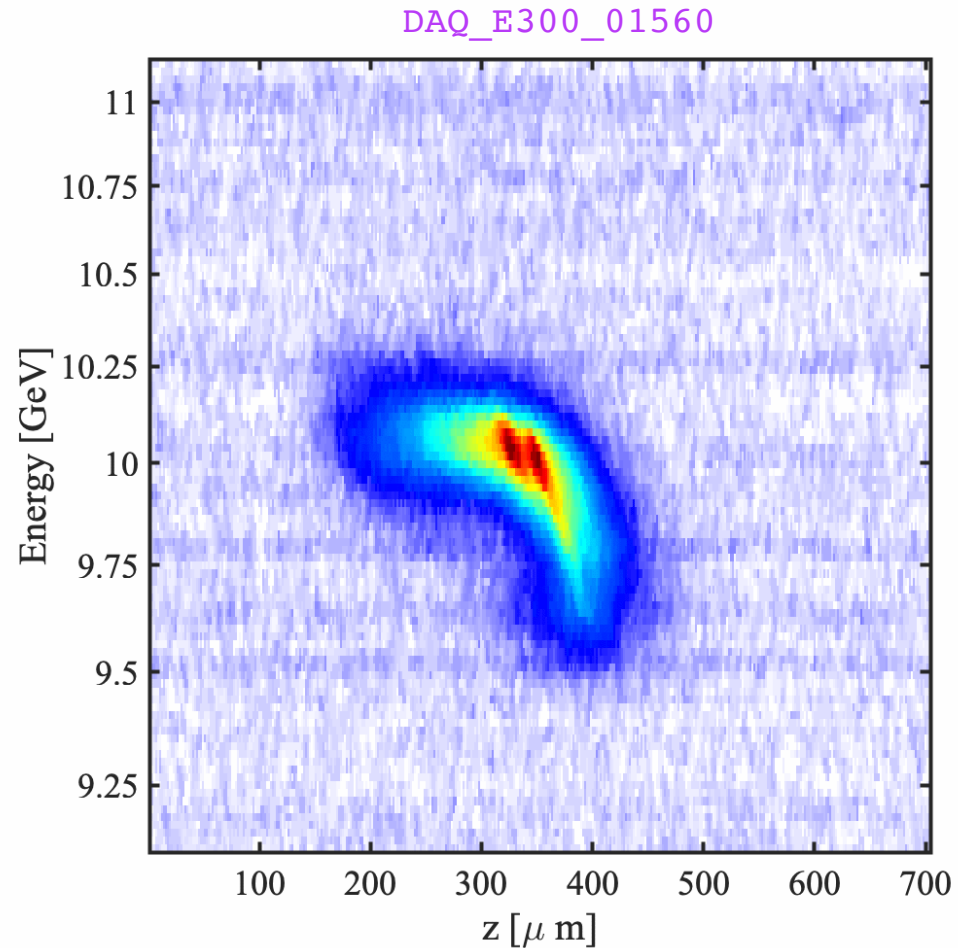

Sub-structure is visible on the e-beam at the few - 10 μ m level with the TCAV.

Simulation Slide

TCAV analysis - summary and future improvements

- TCAV has been used to measure bunch lengths down to $\sim 20\text{-}30$ μm RMS in S20.
- Beam arrival time jitter w.r.t. TCAV phase makes calibration measurements challenging.
- Resolution is currently a factor 5-10 worse than analytic estimates/simulation. Contributing factors are: large (>20 μm) emittance in S20, existing correlations and/or mismatches from BC20/upstream, S20 optics (phase advance) not fully understood/optimized for best resolution.
- Future improvements:
 - Emittance in S20 will likely (hopefully) decrease with more machine tuning/understanding
 - Upstream correlations can be minimized e.g. with more time dedicated to sextupole optimization
 - S20 optics will be better characterized after BBA and can be optimized for TCAV operation.
 - TCAV voltage was 20MV in FACET days, now it's 12MV. Increasing voltage will improve the resolution.
- We have not had much beam time to commission and understand TCAV operation. Dedicated beam times should be scheduled to do this in the next run. The lessons learned/progress made will likely benefit all experiments, including E327.

Backup slides

S20 TCAV resolution, analytic estimate

Transverse e- position on the screen

$$\Delta x(z) = S(z + k_{rf}^{-1} \tan \phi)$$

S is the TCAV “streak” in um/um

$$S \equiv eV_{rf}k_{rf} \cos \phi |\sin \Delta\psi| \sqrt{\frac{\beta_T \beta_S}{E_T E_S}}$$

Beta function and energy at TCAV and screen

$$\beta_T, \beta_S \quad E_T, E_S$$

Longitudinal Res
(smallest feature resolvable)

$$\sigma_z = S^{-1} \sqrt{\sigma_{OTR}^2 + \epsilon \beta_S}$$

OTR/YAG resolution

$$\sigma_{OTR} \sim 4\mu m \quad \sigma_{YAG} \sim 30\mu m$$

SLAC

Energy Res

$$\sigma_\delta = \frac{\epsilon \beta_S}{D_s}$$

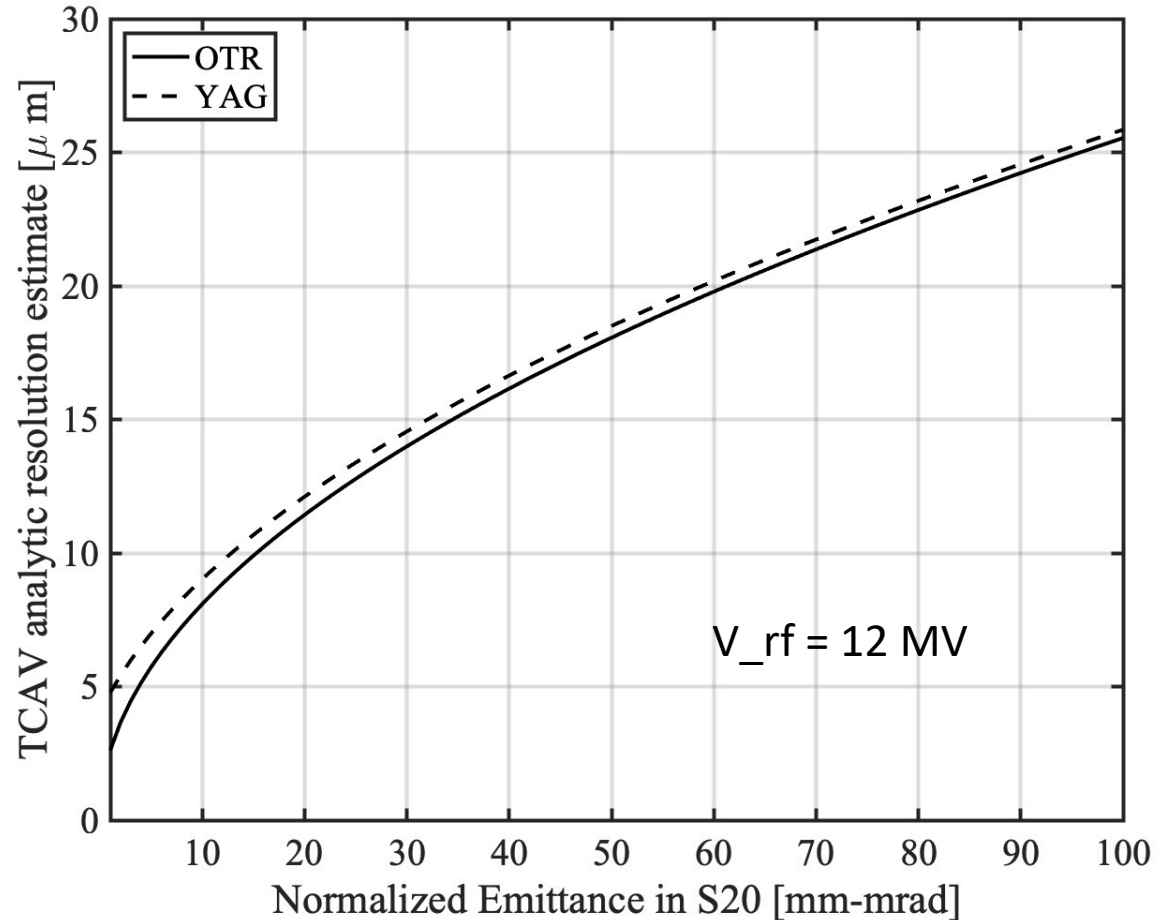

Parameter	Beta Function at TCAV [m]	Beta Function at screen [m]	Energy [GeV]	Phase adv. [deg]	Dispersion at screen [cm]
Value	107	7.1	10	4.3	6.9

TCAV + wire scanner measurements during sextupole tuning 8/22/22

- Correlations in the beam distribution can result in TCAV calibration measurements where the smallest spot size occurs at non-zero voltage (when the TCAV streak undoes the existing correlation on the beam).
- We performed TCAV voltage scans and wire scanner measurements in S20 while tuning sextupoles to achieve small spot sizes.
- This didn't really work i.e. we did not see a change in the spot size, possibly because we were not near peak compression...

TCAV bunch length on CAMR:LI20:107 21-Aug-2022 21:53:28 Asymmetric

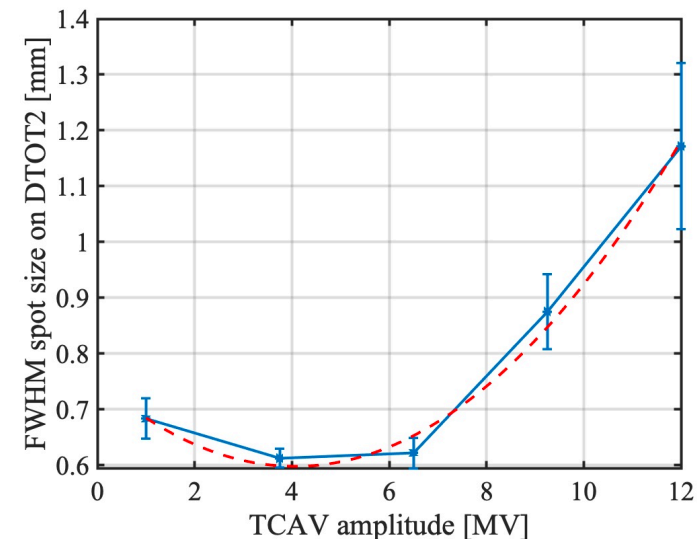
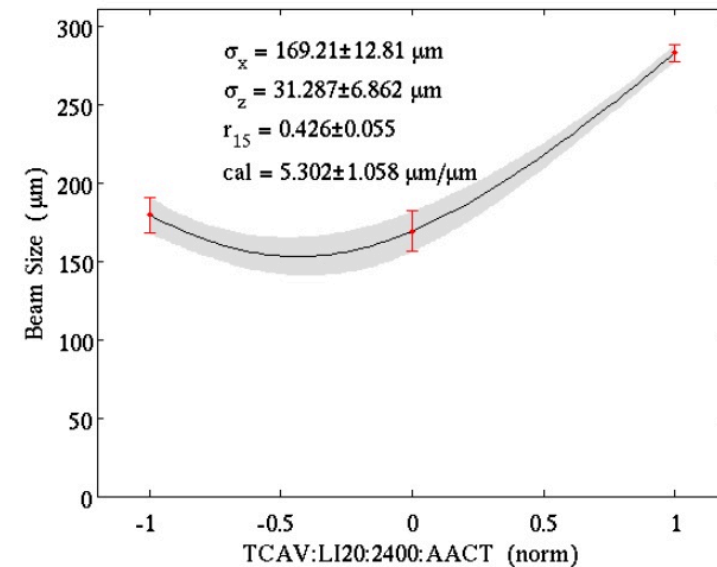

SYAG images from L2 phase scan through full compression 750 pC 7/8/22

Region thought to be around full compression

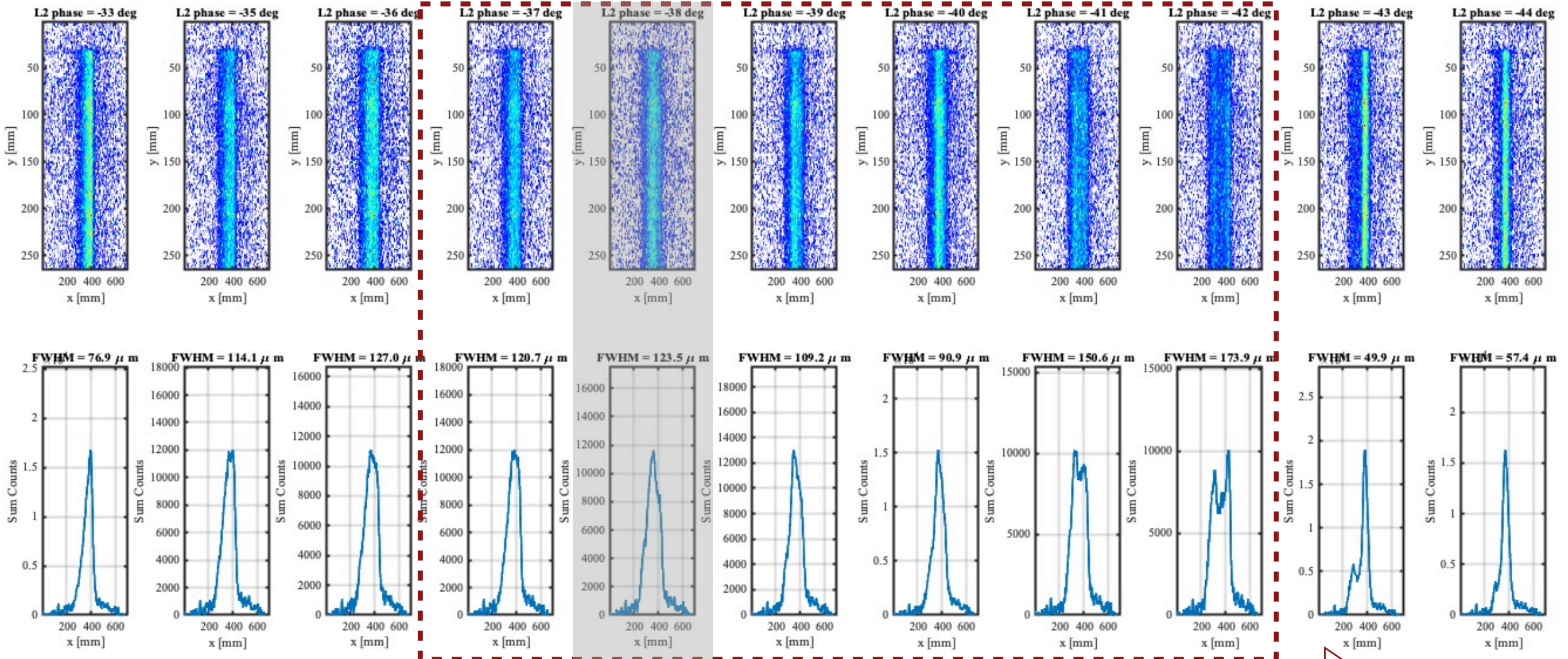

Correlation with SYAG from L2 phase scans through full compression at 750 pC - 7/8/22

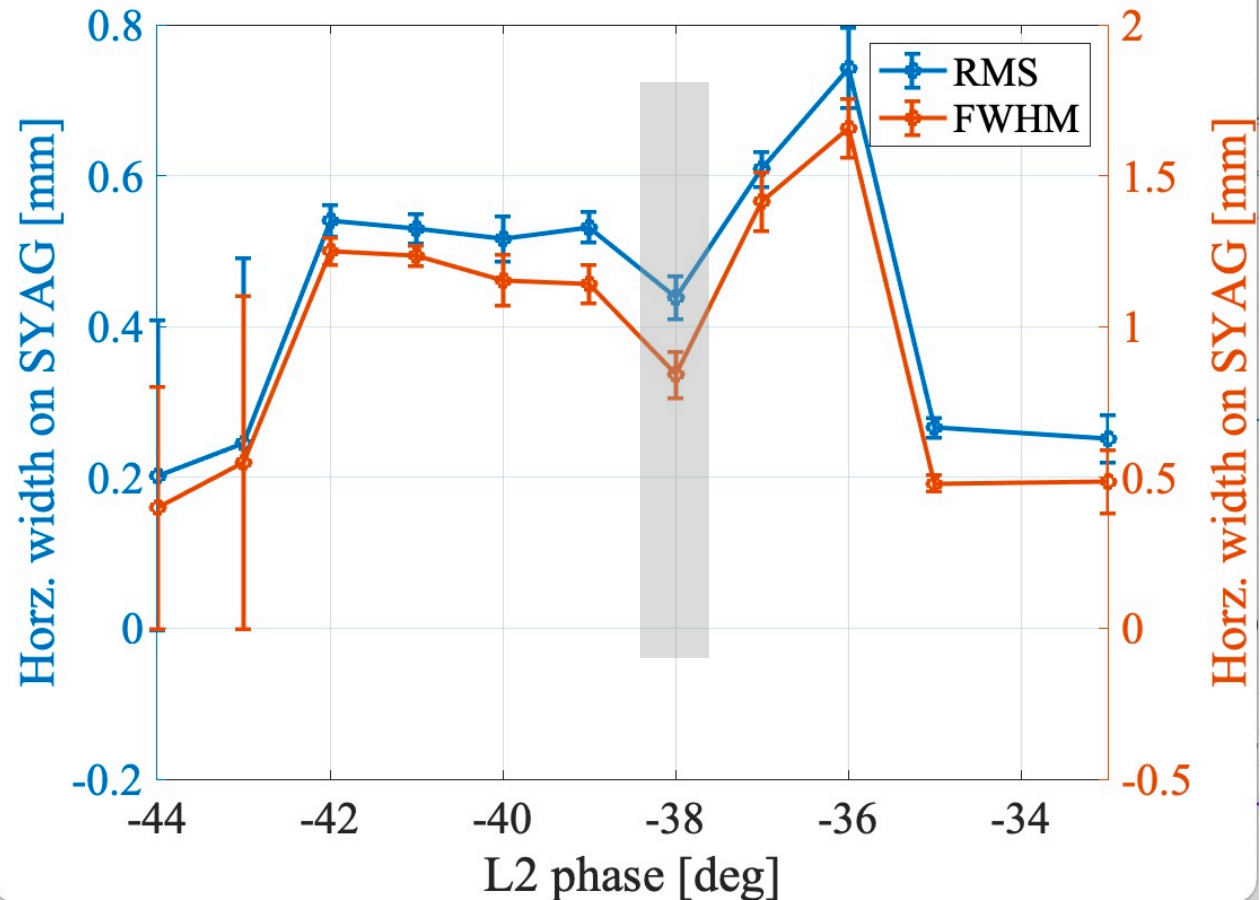
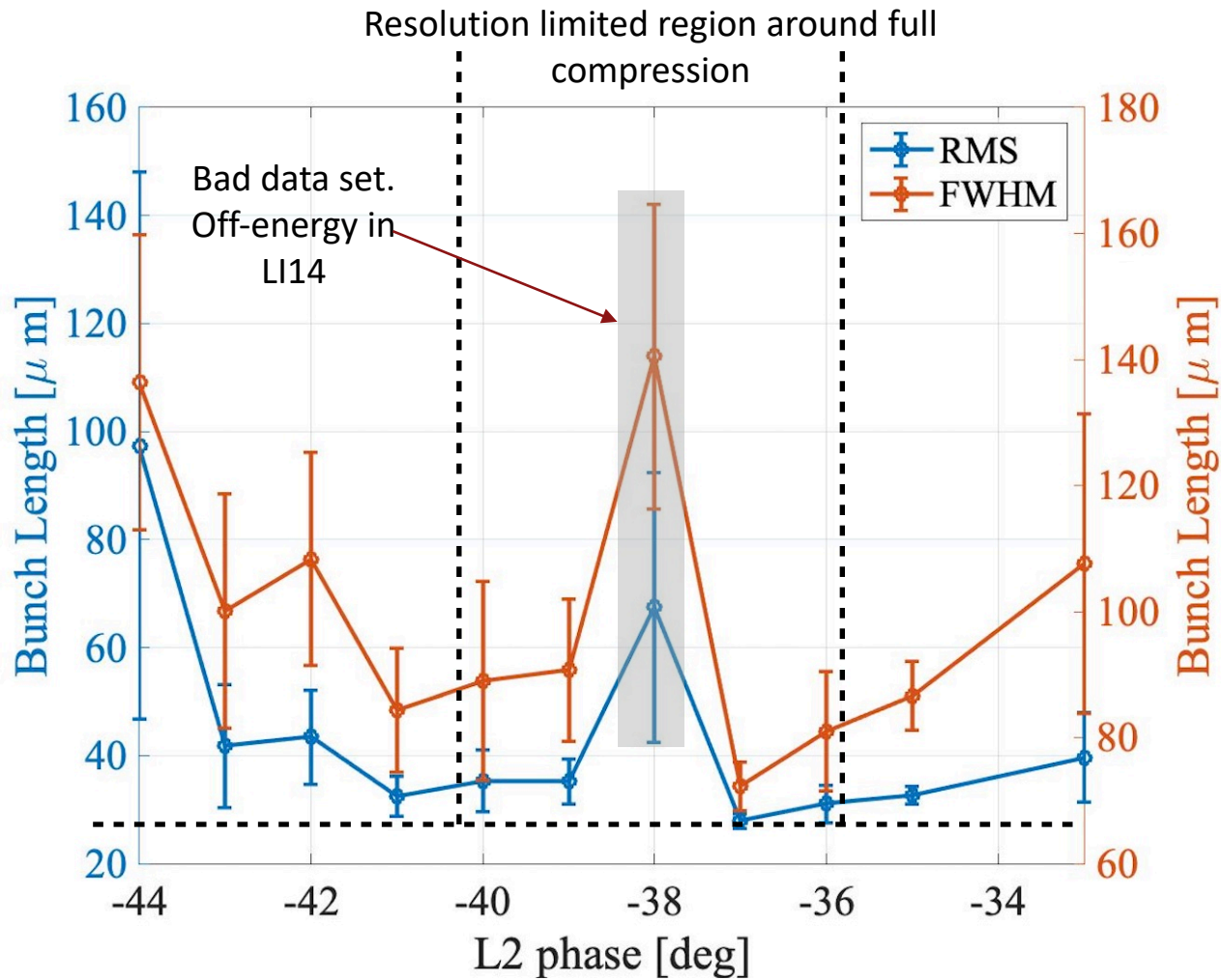

Challenges with TCAV calibration

07/30/2022 22:41 E325 E325_02072 DAQ

Data collection upstream devices. TCAV phase calibration scan. PR10571, PR11375, SYAG, DTOTR2, EOS2, FACET DAQ 02072 for E325. 100 shots per step and 7 steps. Scan of TCAV_LI20_PDES from 87.00 to 93.00 in 7 steps. Path: /nas/nas-li20-pm00/E325/2022/20220730/E325_02072

NAME	SAVE	REQ	MATCH
PR10571	700	700	698
PR11375	700	700	698
SYAG	700	700	698
DTOTR2	700	700	698
EOS2	700	700	698

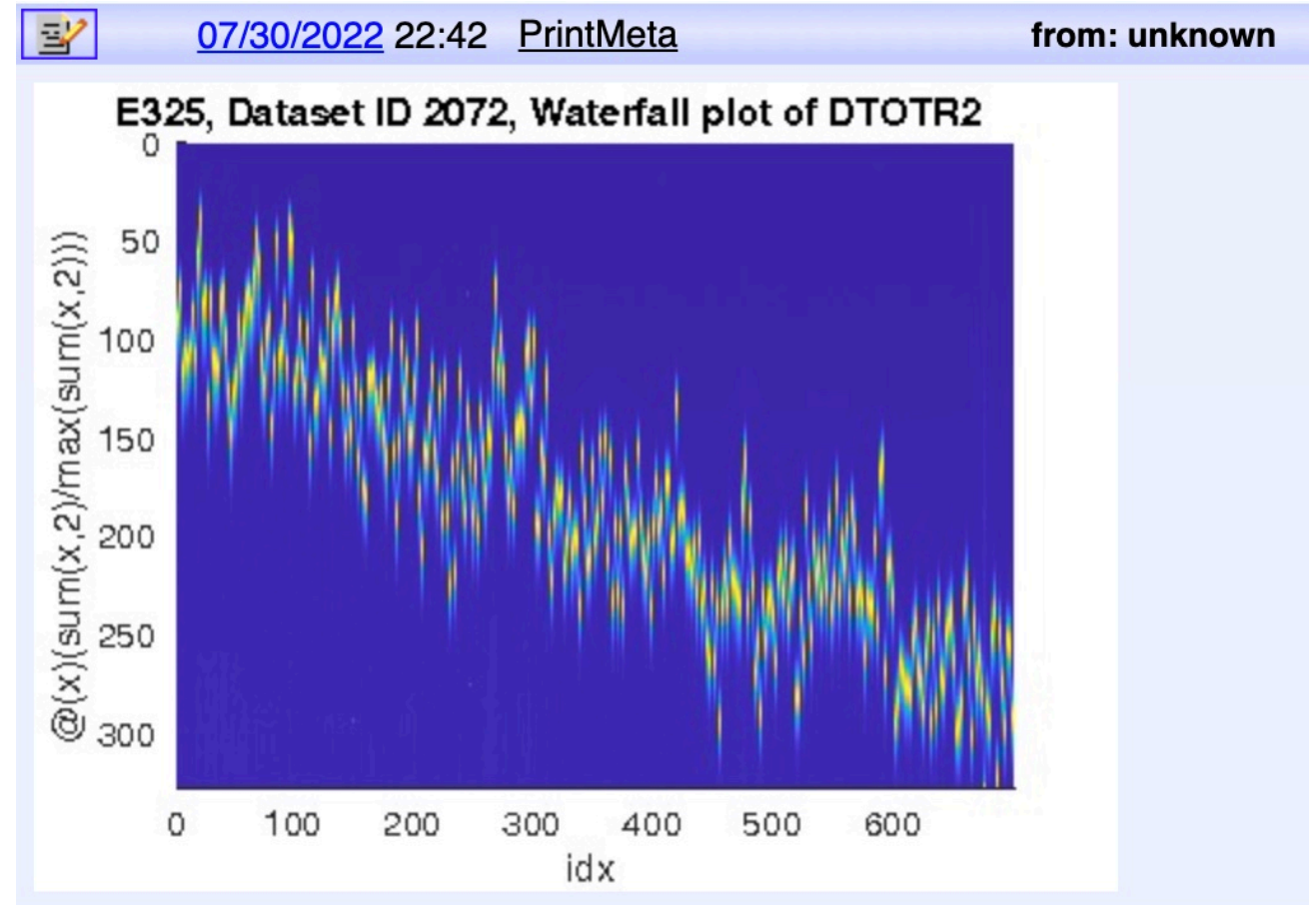

Linac energy and time of arrival jitter make it difficult to get meaningful TCAV calibration

E325 Data set scanning L2 phase 7/31/22 at 1.6 nC

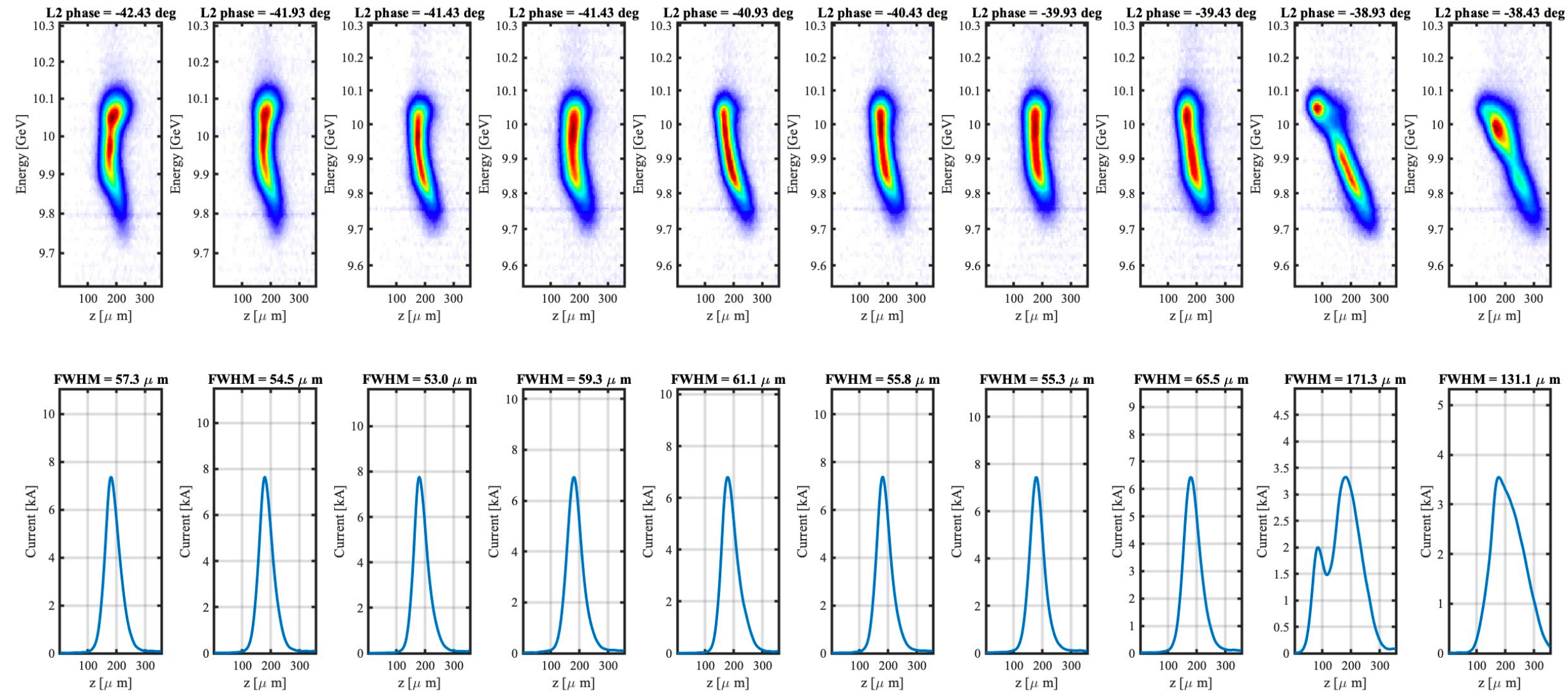

E325 Data set scanning L2 phase 7/31/22 at 1.6 nC

Full compression region appears to be centered near -41 deg in phase. This is shifted by 3-4 degrees compared to the dataset collected at 750 pC on 7/8/22.

Higher charge will increase the chirp from linac wakefields which might explain this. Need to do simulations to see if this explanation makes sense.

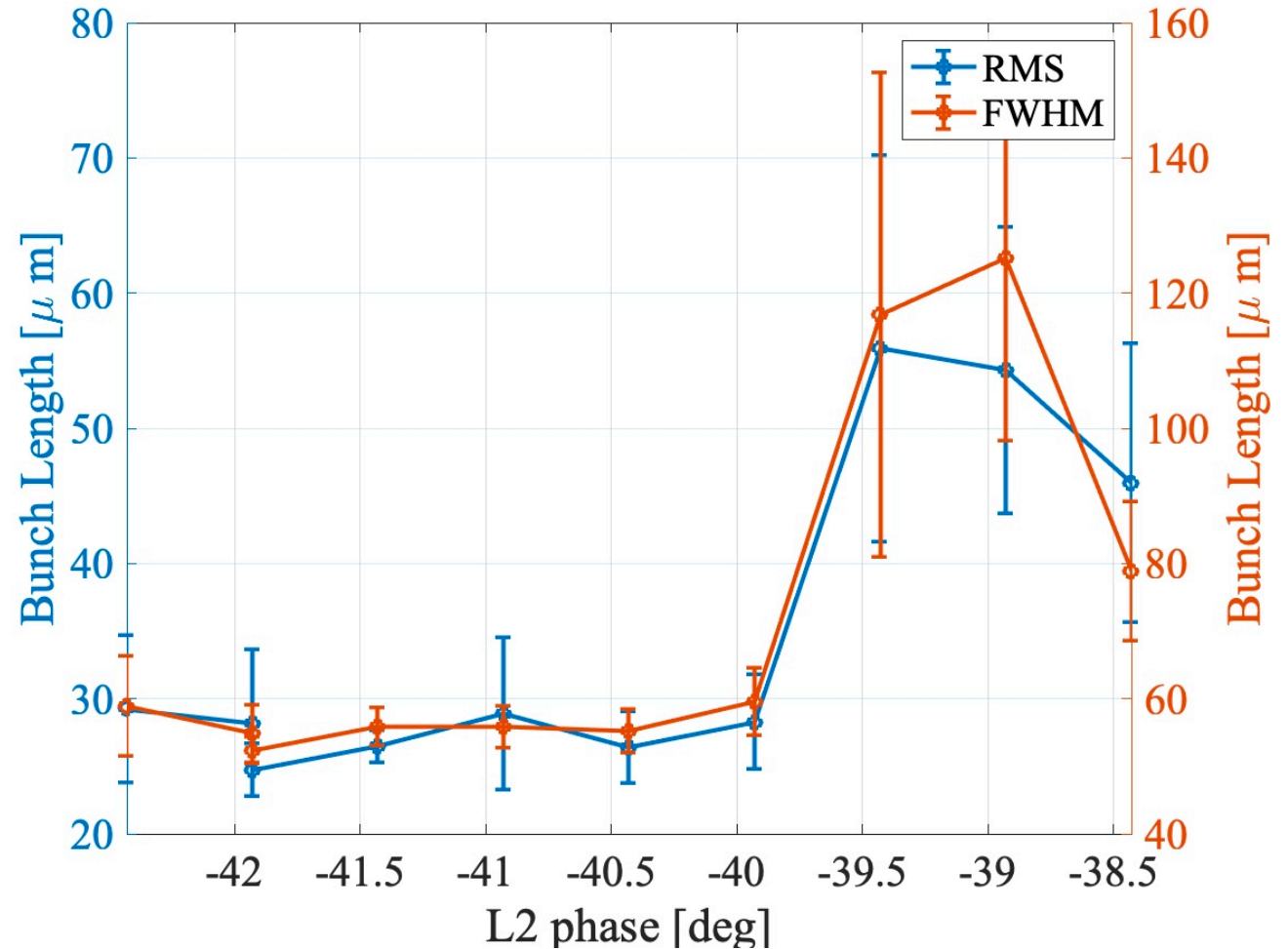

E325 Data set scanning L2 phase 7/31/22 at 1.6 nC

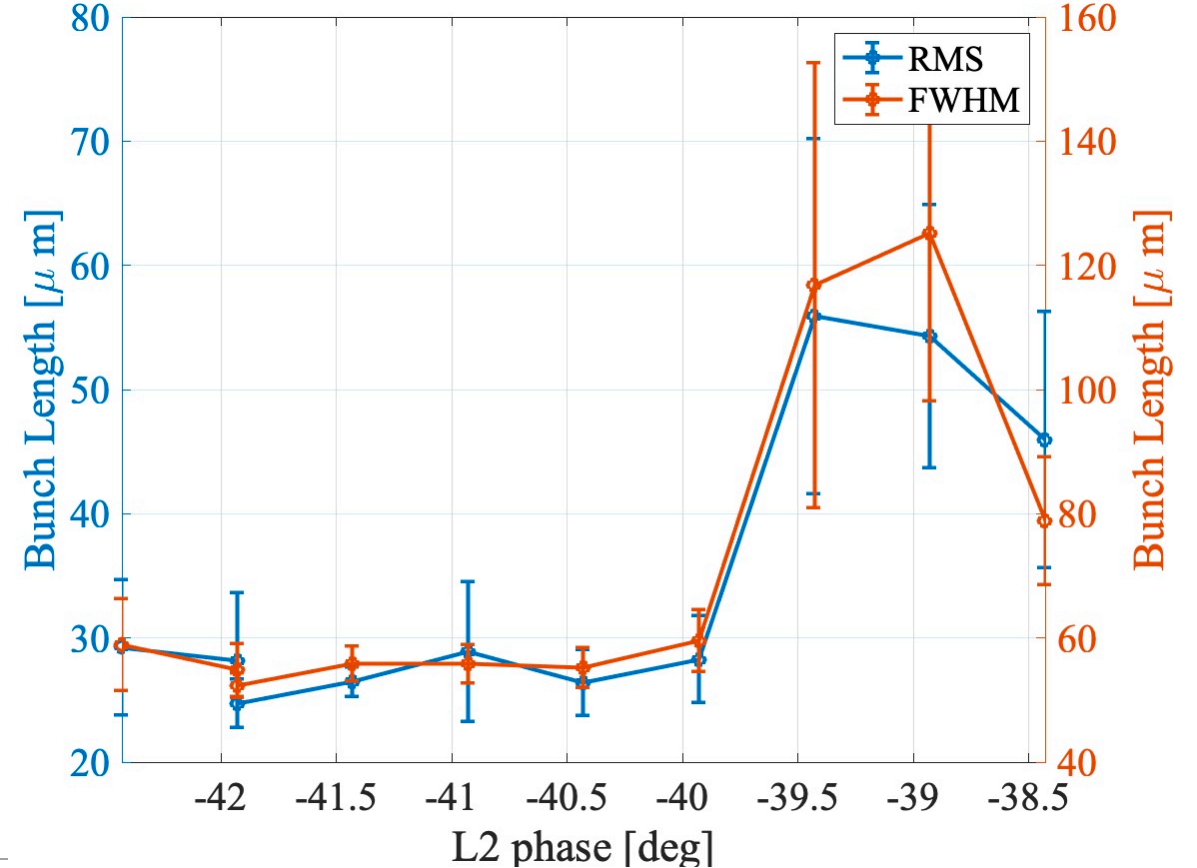
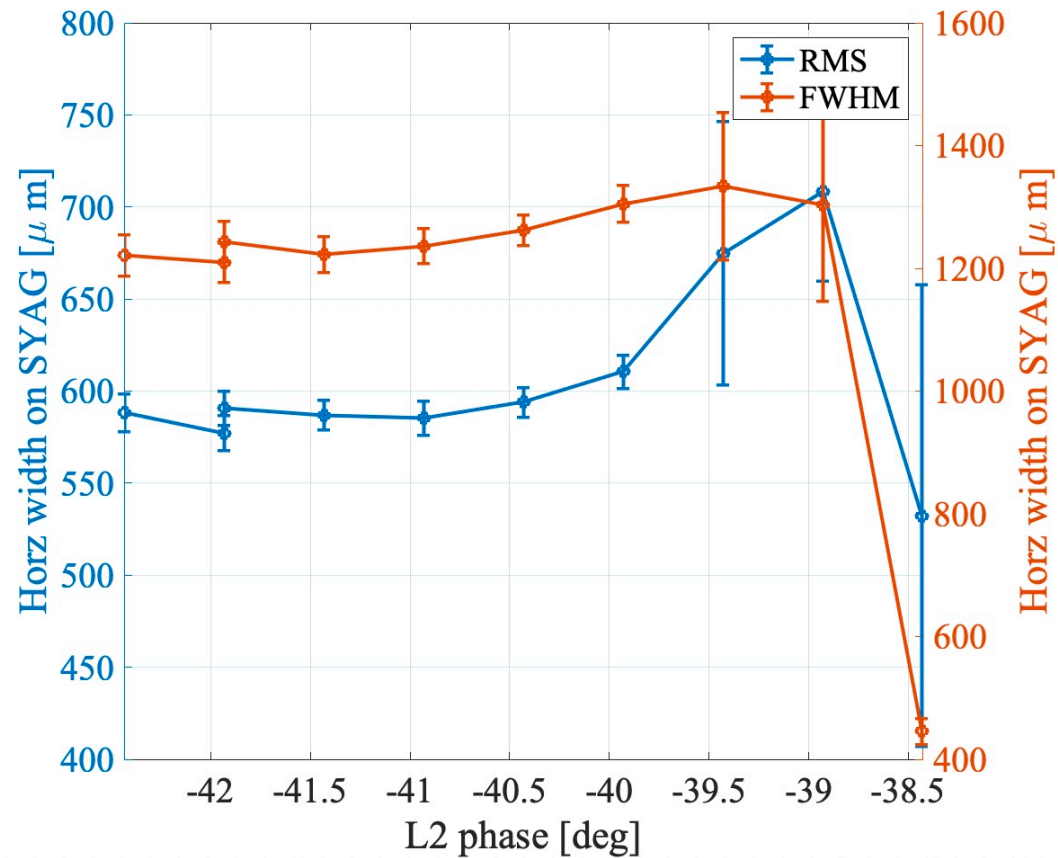

Width on SYAG doesn't correlate very nicely to width on TCAV - if anything it looks like for longer bunches (L2 phase around -39 deg) the SYAG width increases which is counter-intuitive.

Might have to do with the LPS turning into two blobs at that phase.

E325 Data set scanning L2 phase 7/31/22 at 1.6 nC

Width on SYAG doesn't correlate very nicely to width on TCAV

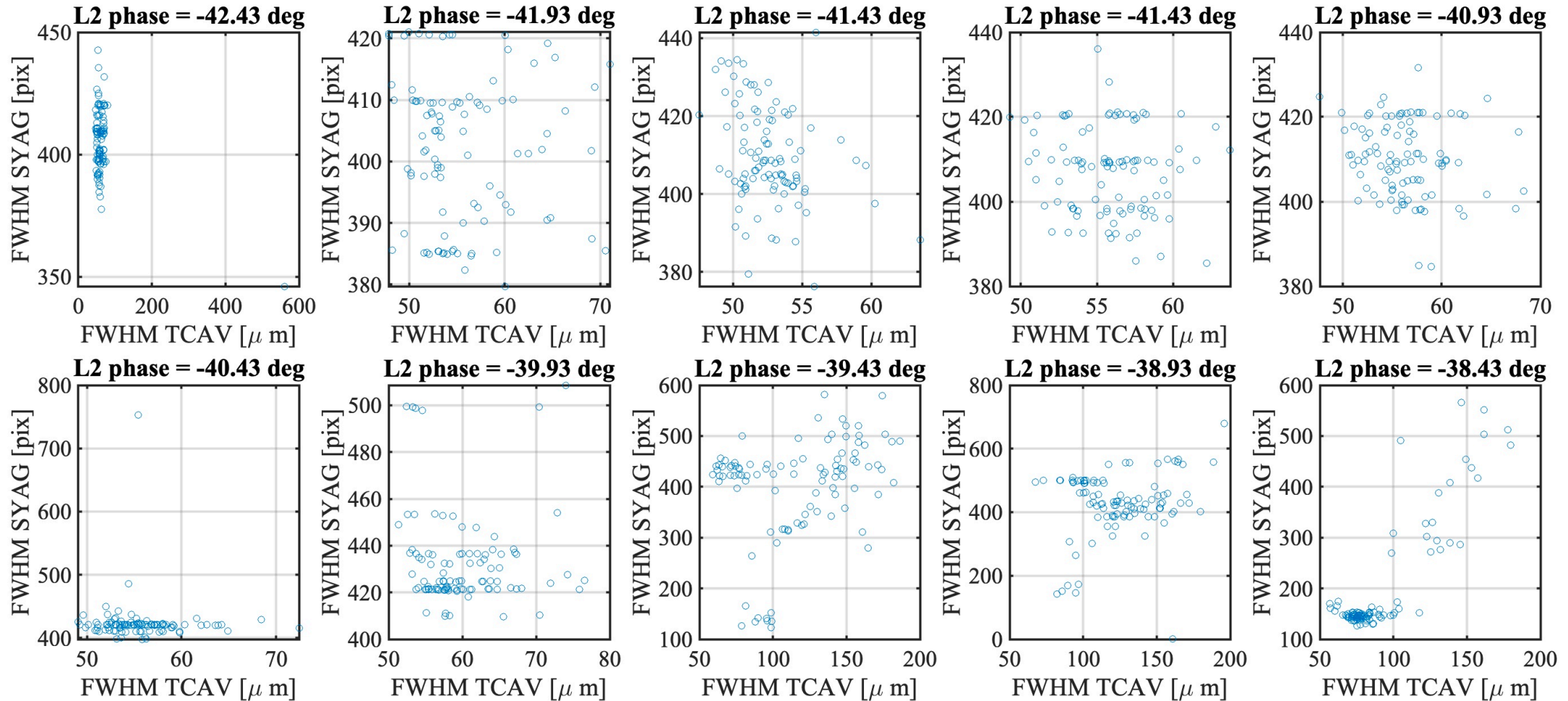

S20 TCAV resolution, ideal beam simulations 10 um bunch length, 10 um S20 emit

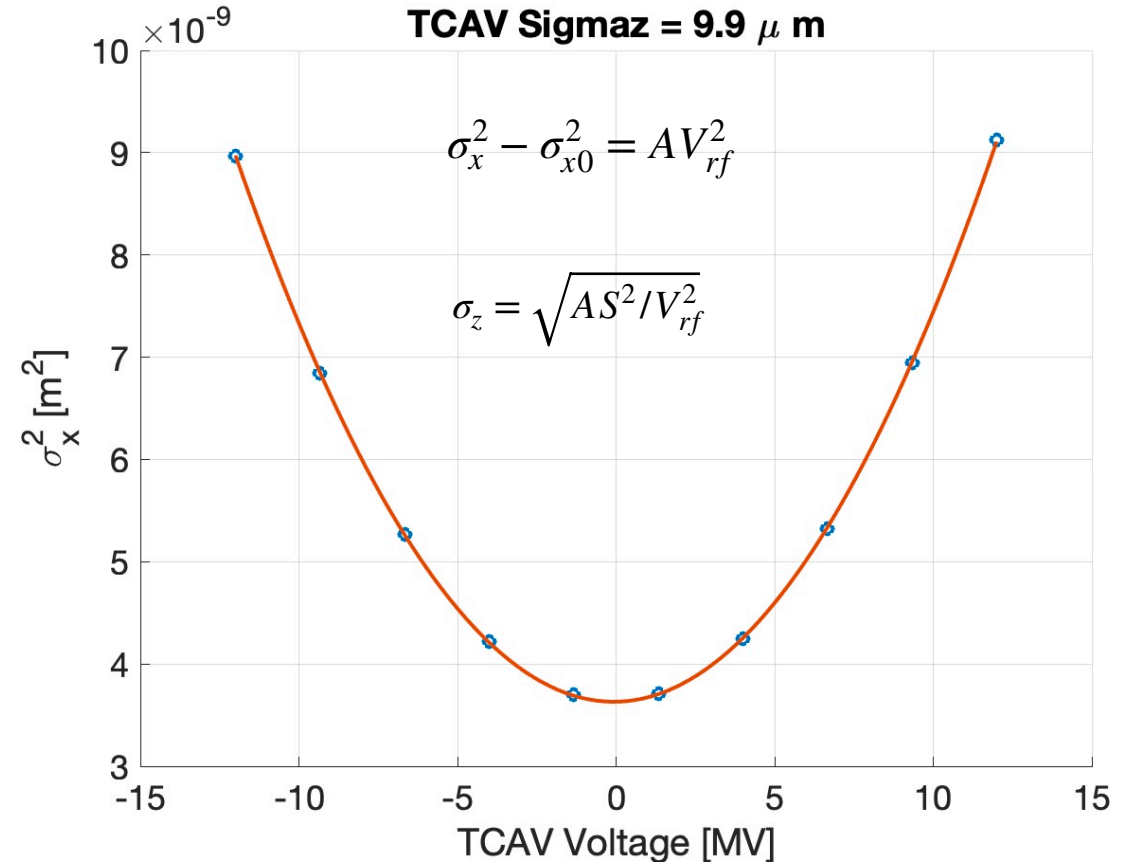
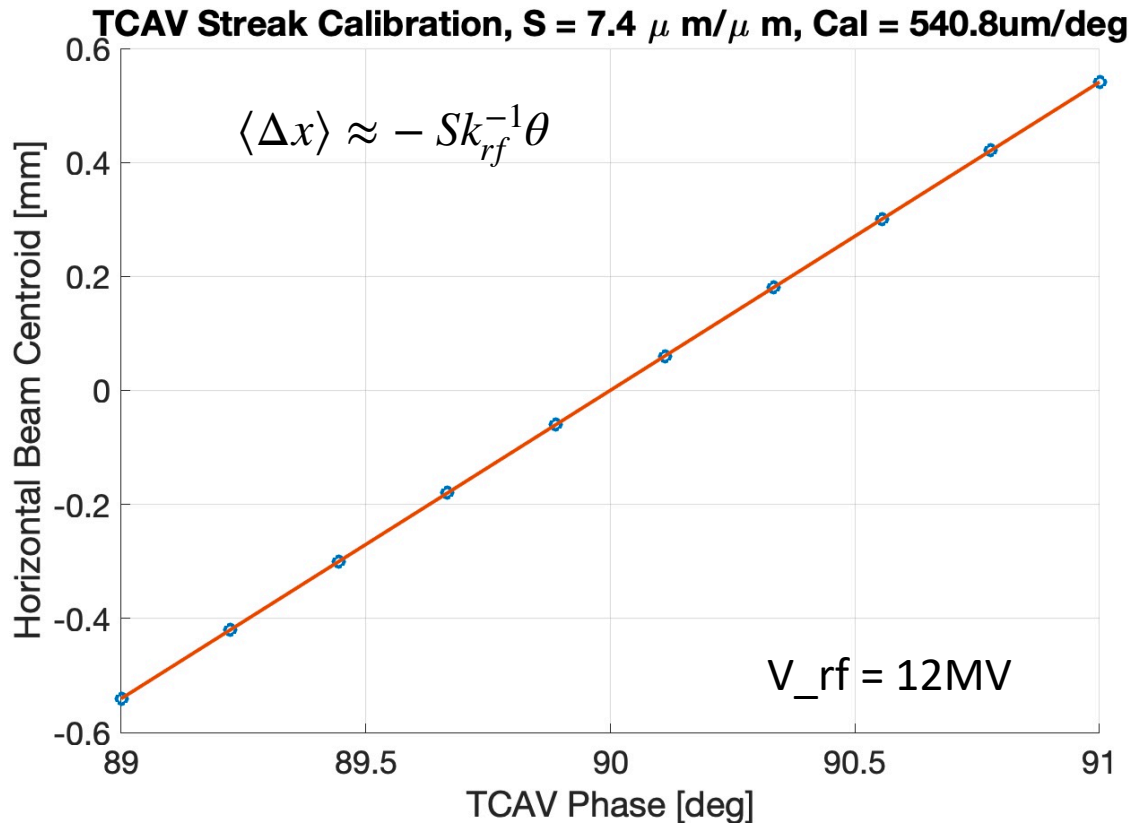

Parameter	Beta Function at TCAV [m]	Beta Function at screen [m]	Energy [GeV]	Phase adv. [deg]	Dispersion at screen [cm]
Value	107	7.1	10	4.3	6.9

Linac Bunch Compression – Single Bunch

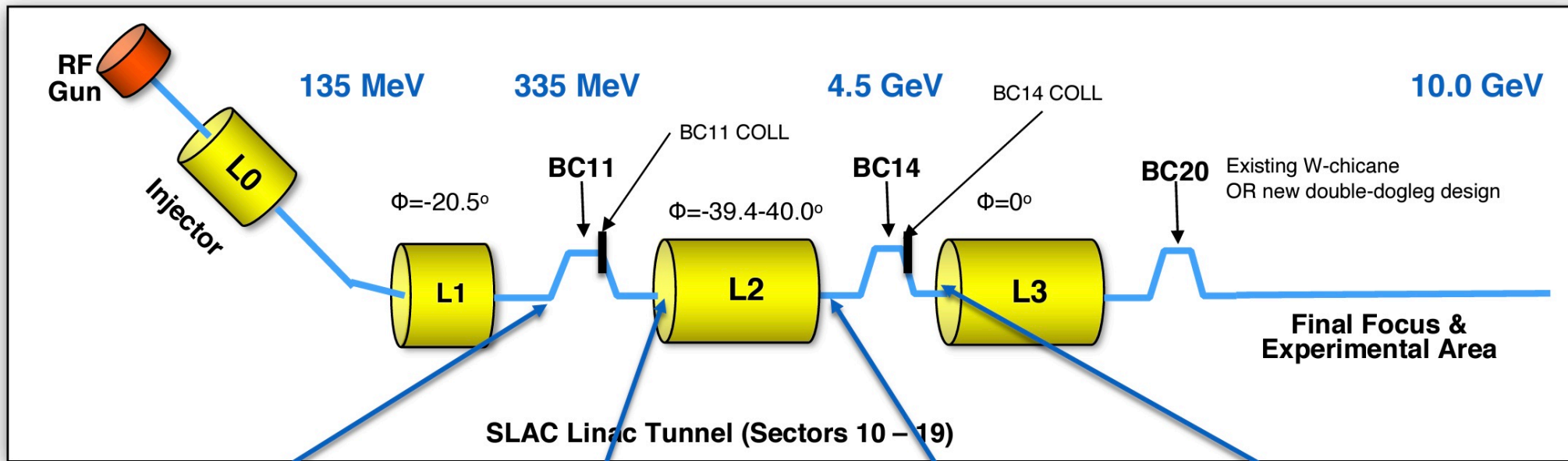

RF phase is degrees from crest

Head of the beam is on the left

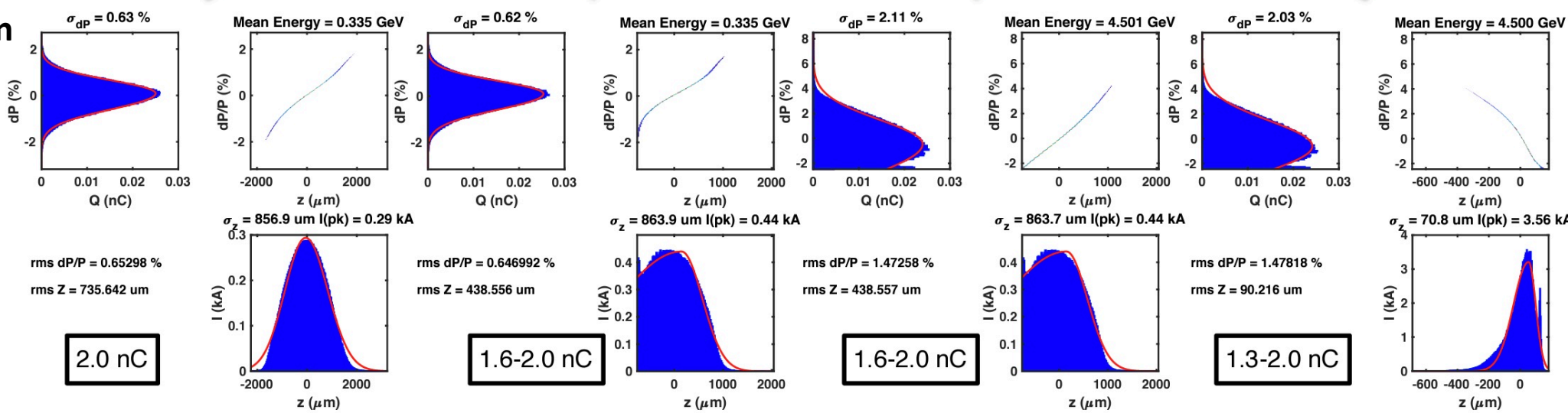
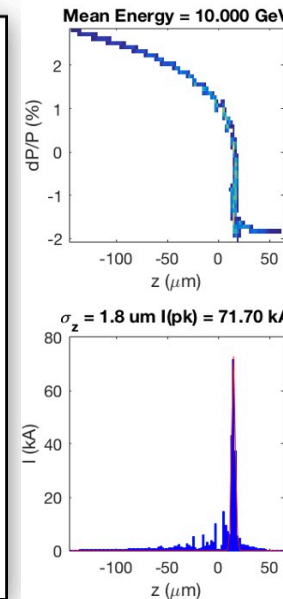

Head of the beam is on the left
Degrees of RF are degrees from crest

L2 phase scans in simulation

L1phase = -20.5 deg for all sims

More negative phase (more chirp) in L2 means you are more over-compressed after BC14.

Full (or over) compressed after BC14 means over-compressed after BC20

Small phase changes (+/- 1 deg) have much larger impact on LPS compared to what we measure on the accelerator.

This is because these sims are done at 7ps FWHM laser on cathode whereas we have closer to 3.8ps FWHM. The bunch is therefore shorter in reality in L2 so phase changes have a smaller effect on the LPS. (G. White)

L2phase = -39.25 deg
Over-compressed

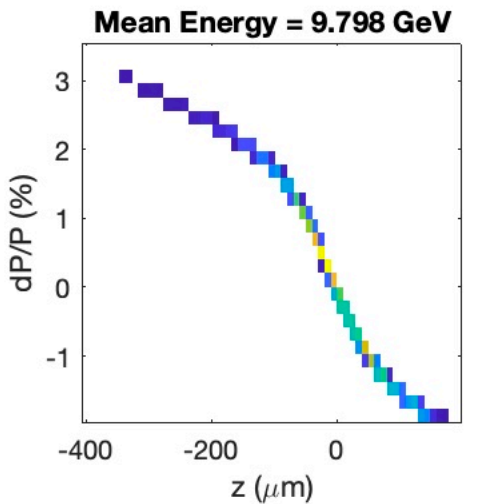

$\sigma_z = 67.691 \mu\text{m}$ $I(\text{pk}) = 3.68 \text{ kA}$

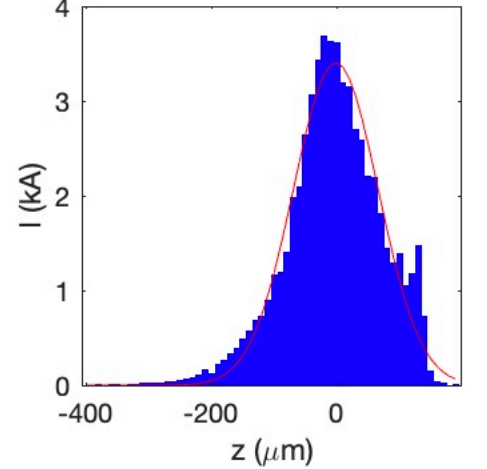

L2phase = -38.25 deg
Fully compressed

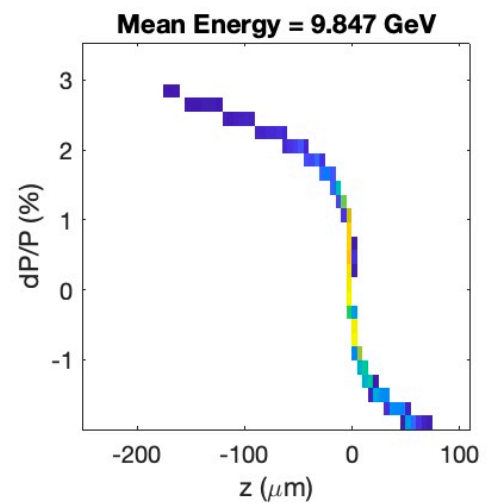

$\sigma_z = 2.723 \mu\text{m}$ $I(\text{pk}) = 45.77 \text{ kA}$

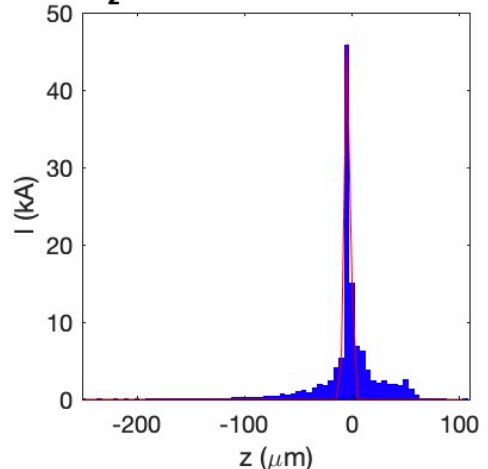

L2phase = -37.25 deg
Under compressed

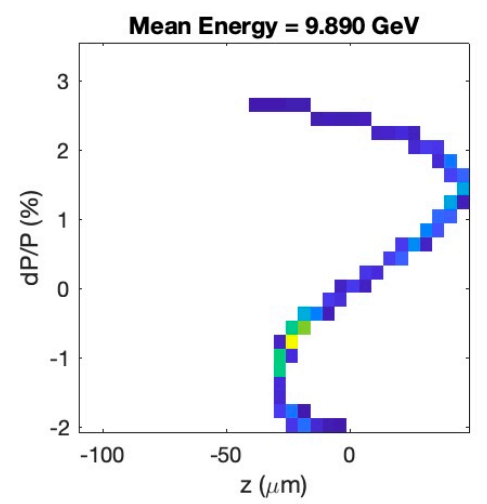

$\sigma_z = 57.685 \mu\text{m}$ $I(\text{pk}) = 27.88 \text{ kA}$

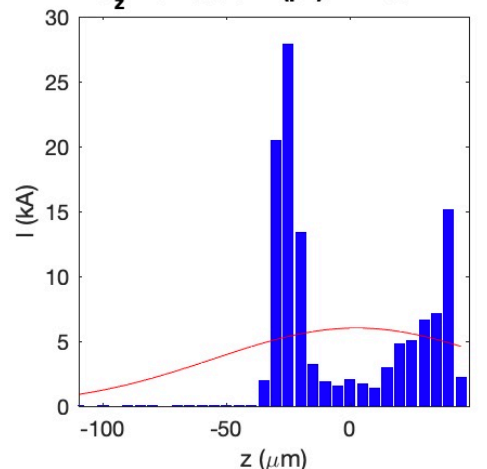

L2 phase scans in simulation 3ps laser (ops parameters)

L1phase = -19.5 deg for all sims

Looks like for +/- 1 around full compression you increase the RMS bunch length to +/- 60 um

L2phase = -40.75 deg
Over-compressed

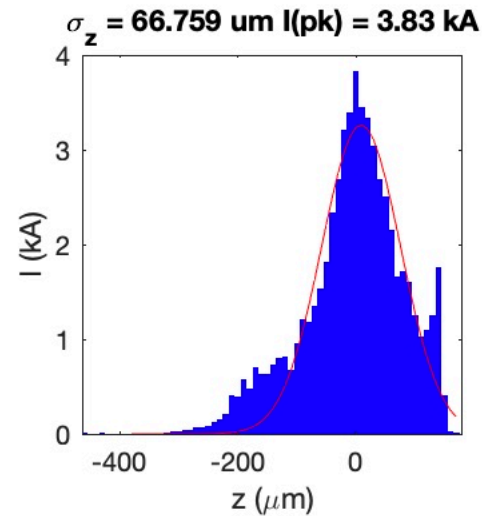
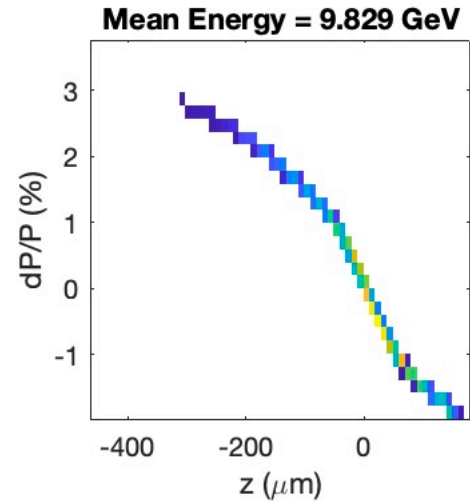

L2phase = -39.75 deg
Fully compressed

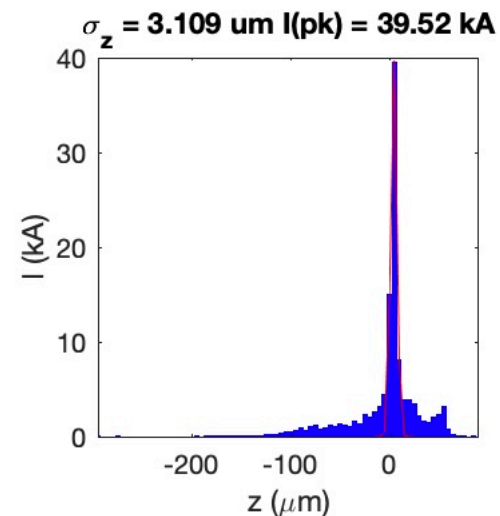
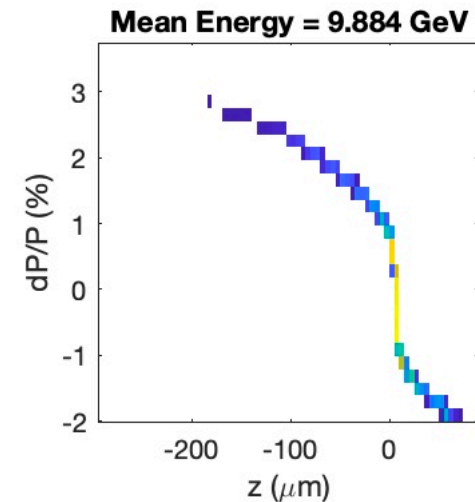

L2phase = -38.75 deg
Under compressed

