

# Expected performance

J. Va'vra

# Content

- **Do SiPMTs actually work at 5 Tesla ?**
- **Various error contributions to Cherenkov angle resolution**
- **PID performance = f(momentum)**

# Do SiPMTs actually work at 5 Tesla ?

- Contact Robert Klanner.
- **My question to him:** Did anybody tried to run SiPMTs at 4–5 Tesla ? Would they work ? In this application, the field would be tangential to face, i.e., SiPMTs would be placed on a barrel.
- **His answer:** No effects are expected. Measurements at 7 T:  
S. Espan a et al.,  
<https://core.ac.uk/download/pdf/30044497.pdf> (NIM)

Greetings,  
Robert

# Chromaticity: TMAE vs SiPMTs

J. Va'vra

Gas RICH Performance - TMAE vs. SiPMTs

J.V., 10/19/2021

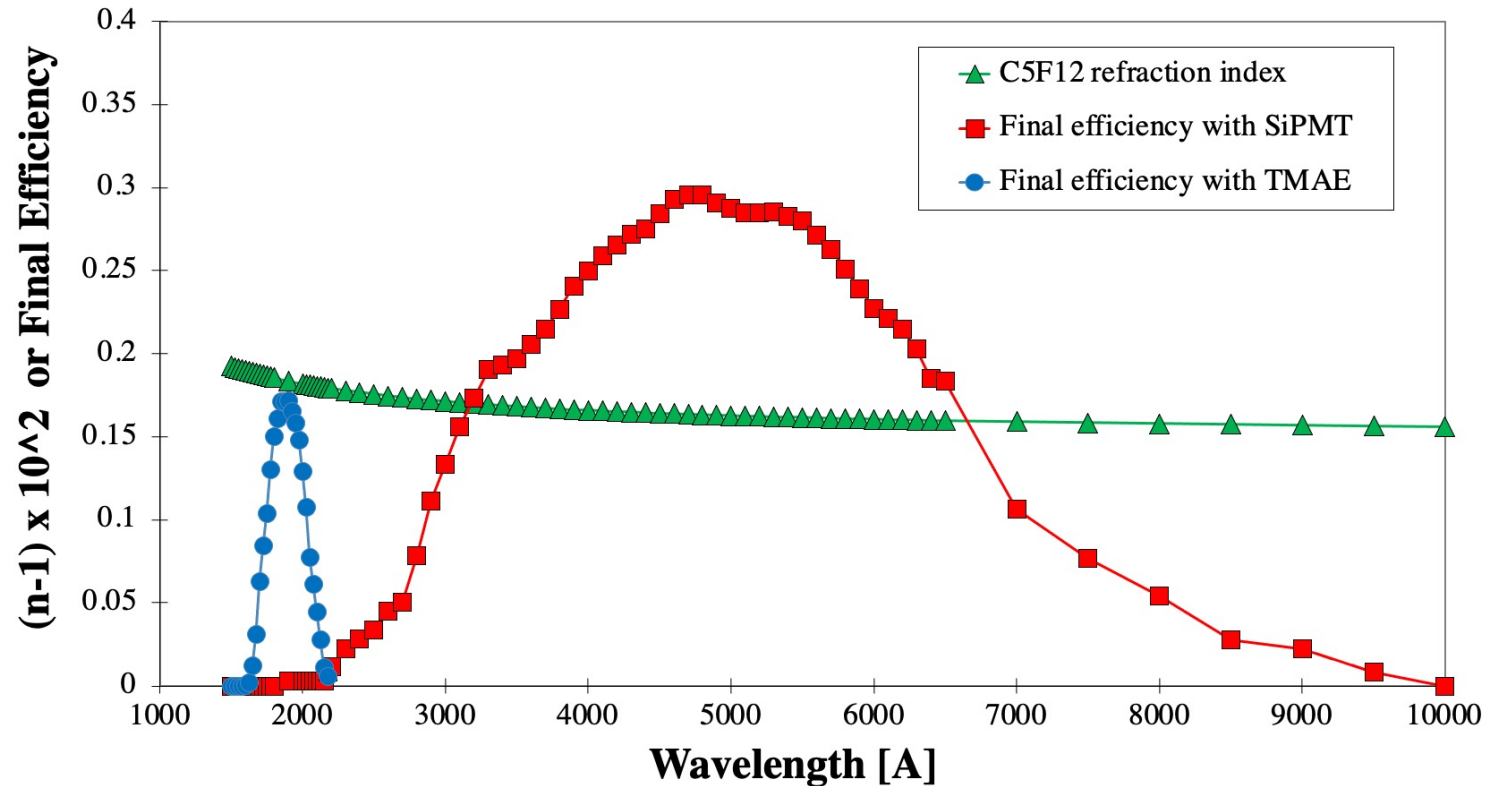

- Although CRID operated in a region where refraction index changed more rapidly, its wavelength acceptance was very narrow and therefore the chromatic error was smaller than in case of SiPMTs – see later.

# Chromatic error

- $\sigma_{\theta_c} |_{\text{single photon}} \sim \frac{d\theta_c}{dE} (E_2 - E_1) \frac{1}{\sqrt{12}} = f(\text{gas choice, detector})$
- Cherenkov angle:  $\theta_c = \arccos\left(\frac{1}{n\beta}\right) = f(E) \sim \arccos\left(\frac{1}{n}\right)$  for  $\beta \sim 1$
- $E$  is photon energy,
- $E_2$  &  $E_1$  are bandwidth acceptance limits

# CRID: Chromatic error = f(n(E))

J. Va'vra

J.V., 10/26/2021

## CRID: C<sub>5</sub>F<sub>12</sub> Cherenkov angle for $\beta = 1$ and refractive index

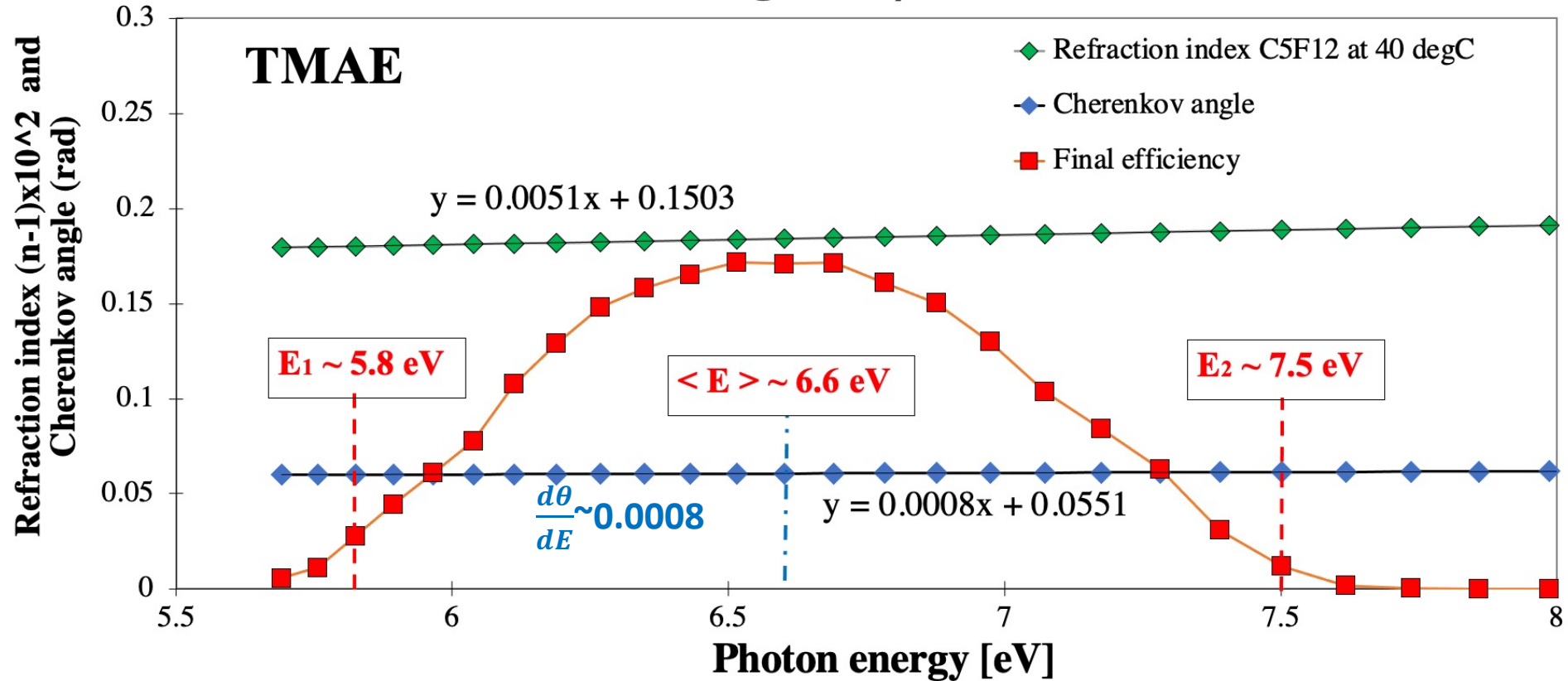

$$\sigma_{\theta_c} \sim \frac{d\theta_c}{dE} (E_2 - E_1) \frac{1}{\sqrt{12}} \sim \mathbf{0.4 \text{ mrad}}, \quad \theta_c(E_{\text{mean}}) \sim \mathbf{60 \text{ mrad}}, \quad \frac{\sigma_{\theta_c}}{\theta_c} \Big|_{\text{Chromatic}} \sim \mathbf{0.65\%}$$

# SiD: Chromatic error error = f(n(E))

J. Va'vra

J.V., 10/26/2021

## C4F10: Cherenkov angle and refractive index for $\beta = 1$

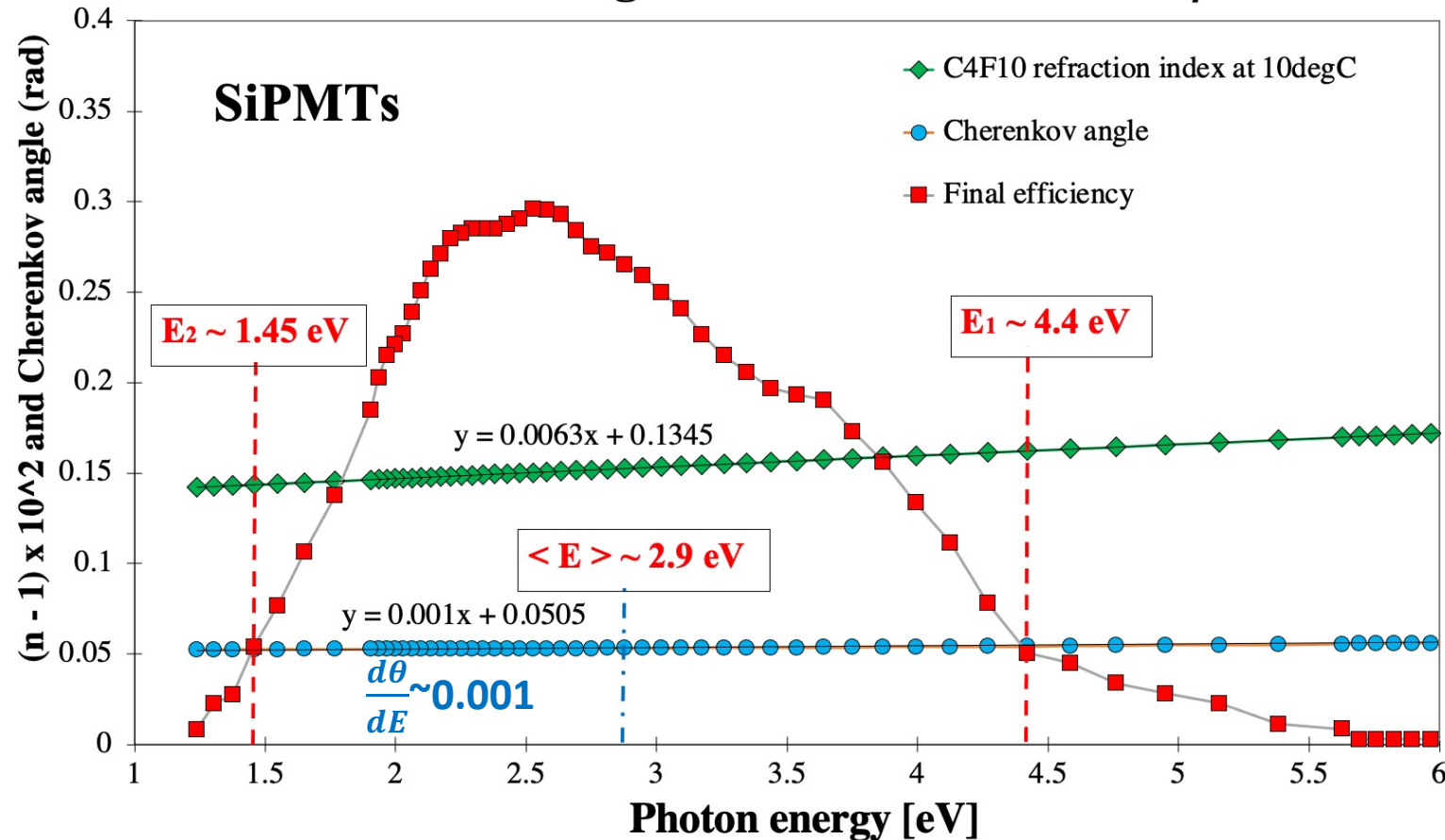

$$\sigma_{\theta_c} \sim \frac{d\theta_c}{dE} (E_2 - E_1) \frac{1}{\sqrt{12}} \sim \mathbf{0.85 \text{ mrad}}, \quad \theta_c(E_{\text{mean}}) \sim \mathbf{53.4 \text{ mrad}}, \quad \left. \frac{\sigma_{\theta_c}}{\theta_c} \right|_{\text{Chromatic}} \sim \mathbf{1.6\% !!}$$

# Angular error due to track bending

J.Va'vra

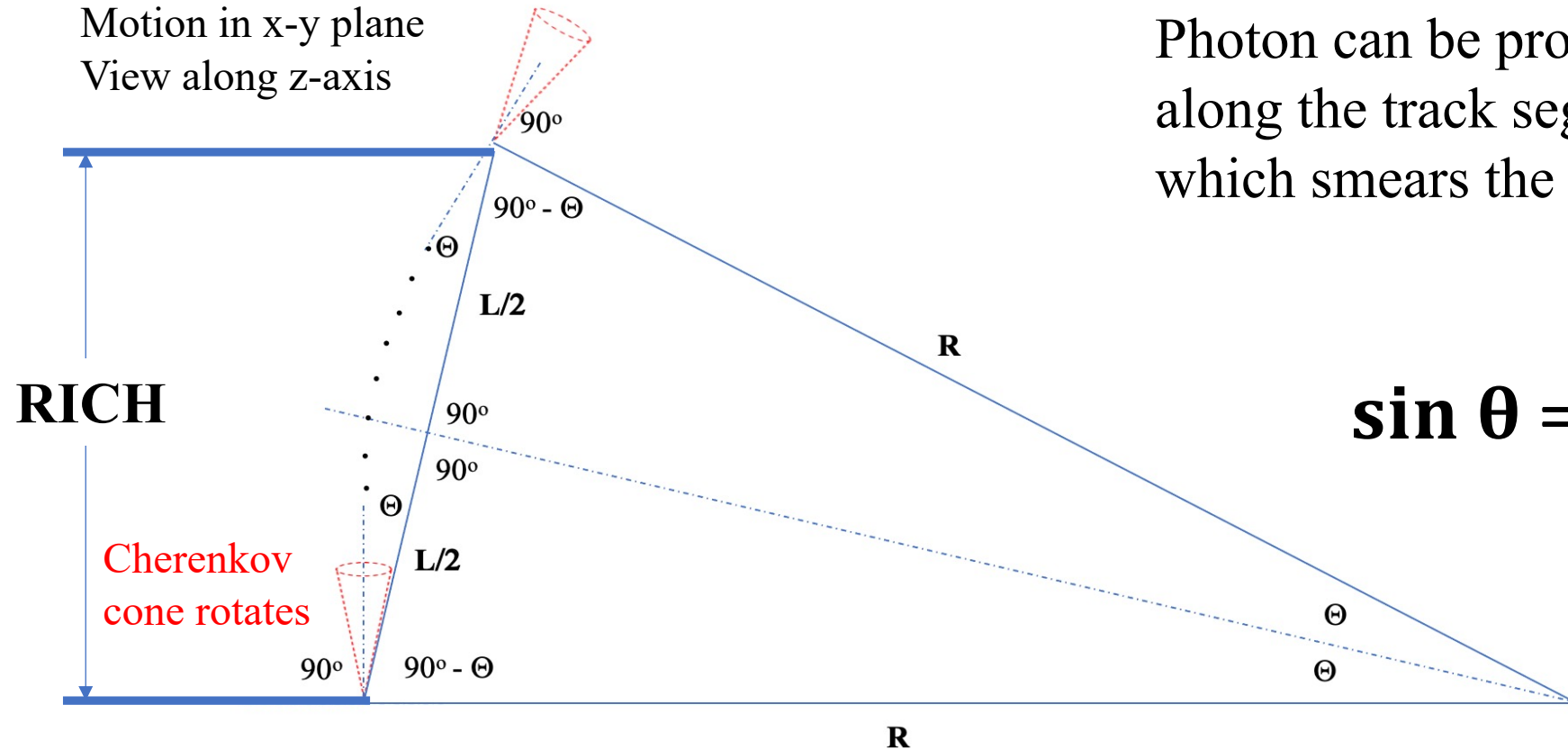

Photon can be produced anywhere along the track segment along path L, which smears the Cherenkov angle

$$\sin \theta = \left[ \frac{\left(\frac{L}{2}\right)}{R} \right]$$

$$\sigma_\theta \sim \frac{2\theta}{\sqrt{12}} \sim \left\{ 2 \arcsin \left[ \frac{\left(\frac{L}{2}\right)}{R} \right] \right\} \frac{1}{\sqrt{12}}, \quad R = \frac{p}{300 B}, \quad L = 0.25 \text{ m}, \quad p \text{ [MeV/c]}, \quad R \text{ [m]}$$

# SiD: Angular error due to track bending = f(B)

J. Va'vra

J.V., 10/27/2021

$$\sigma_{\theta} \sim \frac{2\theta}{\sqrt{12}} \sim \left[ 2 \arcsin\left[\frac{\left(\frac{L}{2}\right)}{R}\right] \right] \frac{1}{\sqrt{12}}$$

## Resolution due to track bending

J. Va'vra

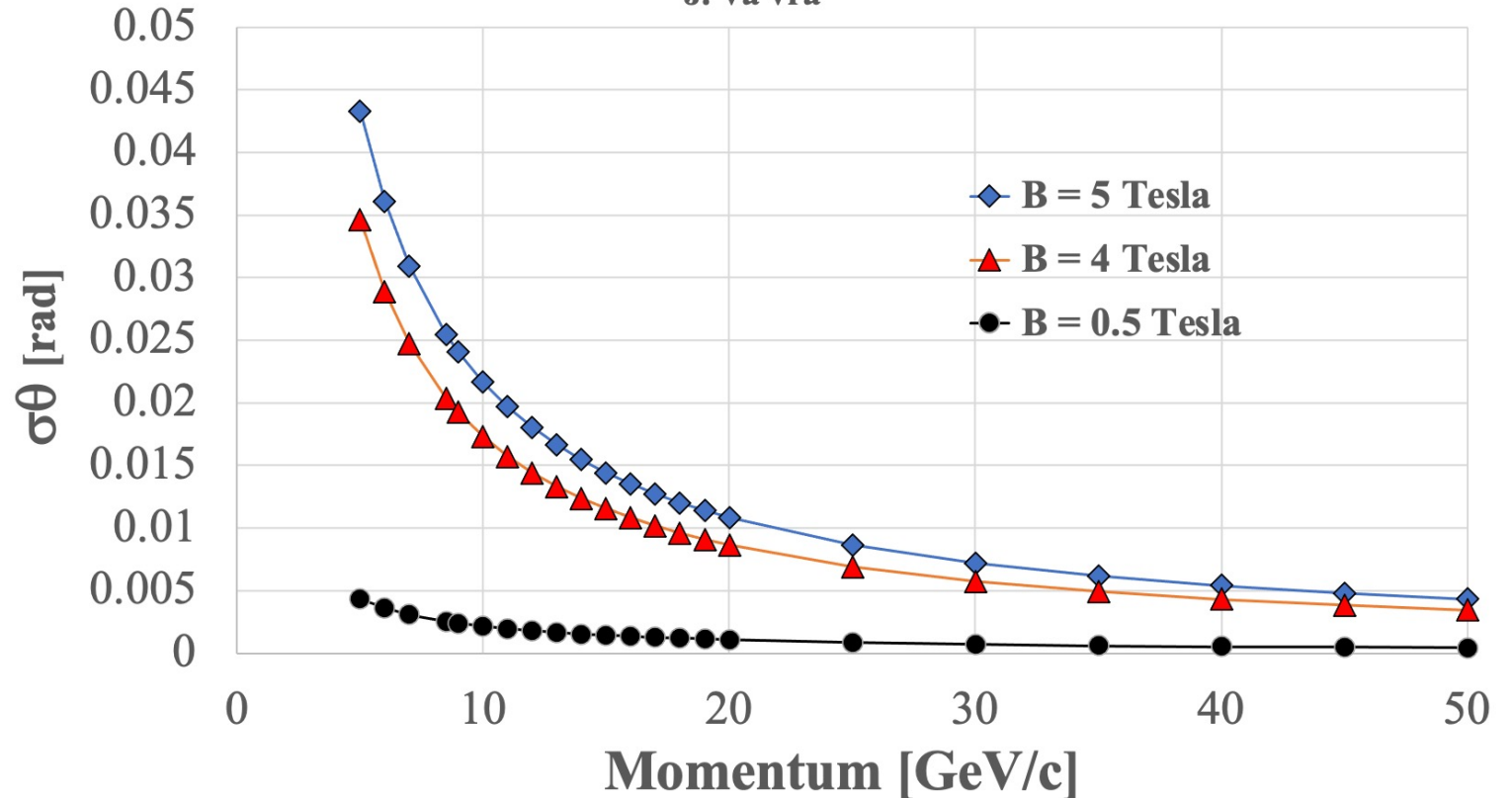

- The angular resolution due to track bending is significant above ~2-3 Tesla

# Total Cherenkov angle error in CRID for $L = 45$ cm

- Chromatic error with  $C_5F_{12}/N_2$  gas and TMAE:  $\sim 0.4$  mrad
- Pixel size effect:  $\sim (0.15\text{cm}/\sqrt{12})/(1.5 \times 45 \text{ cm}) \sim 0.48$  mrad
- Error due to track bending:  $\sim 1-2$  mrad
- Mirror misalignment:  $\sim 0.5$  mrad
- Gas pressure variations, flow changes, distortions, etc.: a few mrad
- **Total:  $\sigma_\theta \sim 4.3$  mrad (per single photoelectron)**

# CRID: PID performance = f(momentum)

J. Va'vra

# of sigmas =

$$\frac{\theta_{\pi} - \theta_K}{\sigma_{\theta} / \sqrt{N}}$$

$\sigma_{\theta}$  is total Cherenkov angle resolution

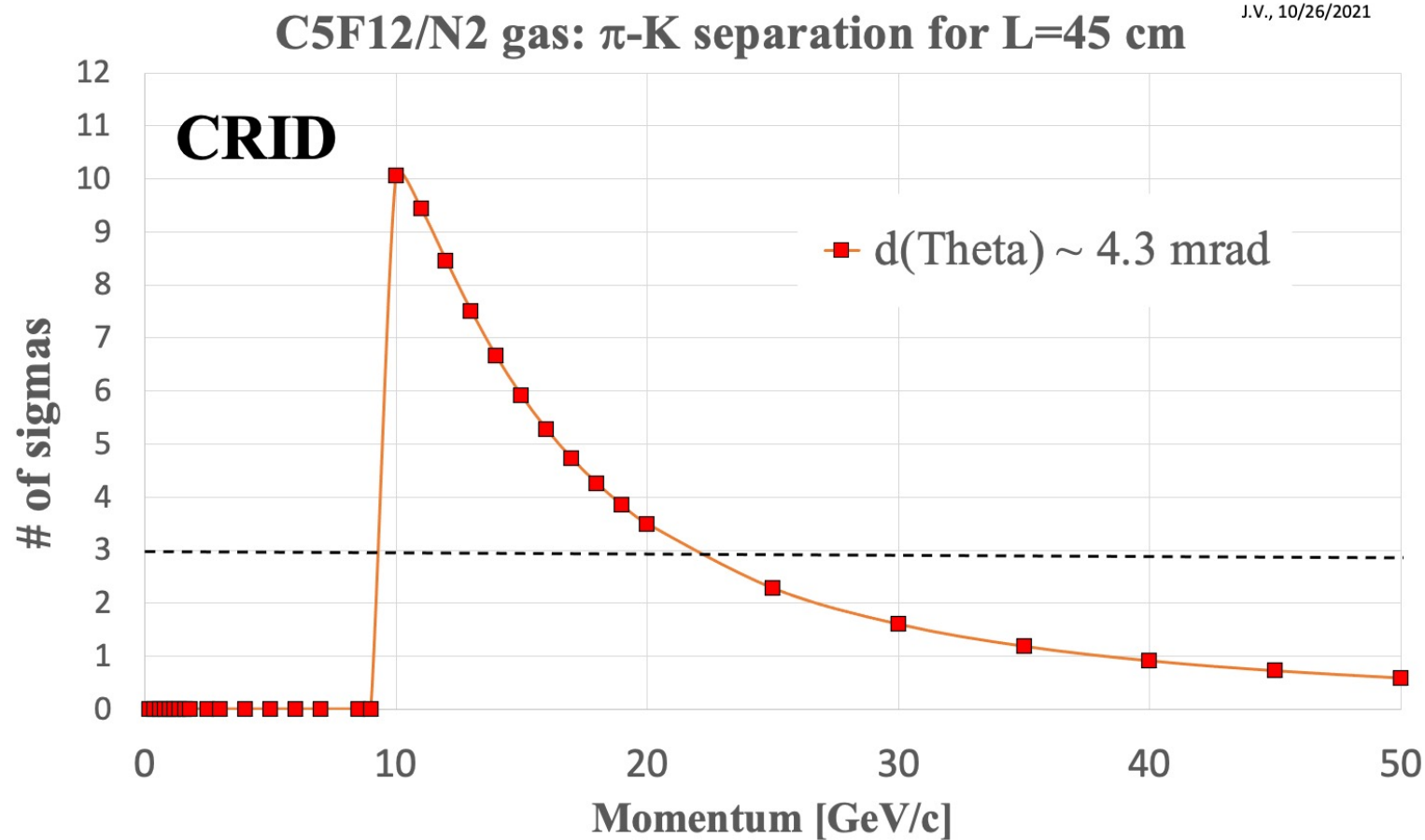

- CRID had 3 sigma  $\pi$ /K separation up to  $\sim 24$  GeV/c.

# Cherenkov angle error in SiD for L= 25 cm

- Chromatic error with C<sub>4</sub>F<sub>10</sub> gas and SiPMT PDE: ~0.85 mrad
- Pixel size effect:  $\sim(0.3\text{cm}/\sqrt{12})/(1.5 \times 25 \text{ cm}) \sim 2.3 \text{ mrad}$
- Error due to track bending: >10 mrad at 3-5 Tesla
- Mirror misalignment: ~0.5 mrad
- Gas pressure variations, flow changes, distortions, etc.: ?
- **Total:  $\sigma_\theta$  can be >10 mrad at larger magnetic field !!**

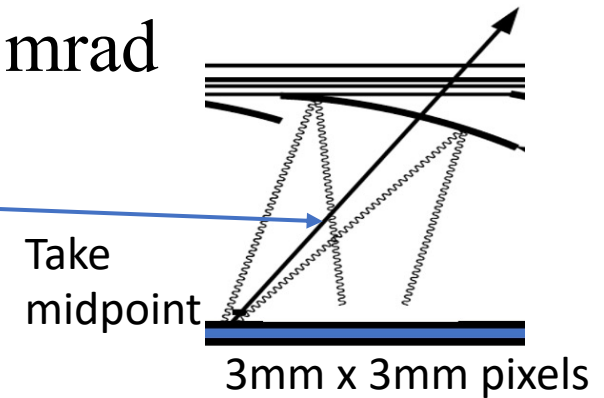

# CRID: Threshold behavior

J. Va'vra

$$N_o = \frac{\left(\frac{\alpha}{hc}\right) \int \text{Eff}(E) [\sin(\theta_c)]^2 dE}{[\sin(\langle\theta_c\rangle)]^2}$$

$$N_{pe} = N_o L [\sin \langle \theta_c \rangle]^2$$

$\langle \theta_c \rangle$  is mean Cherenkov angle

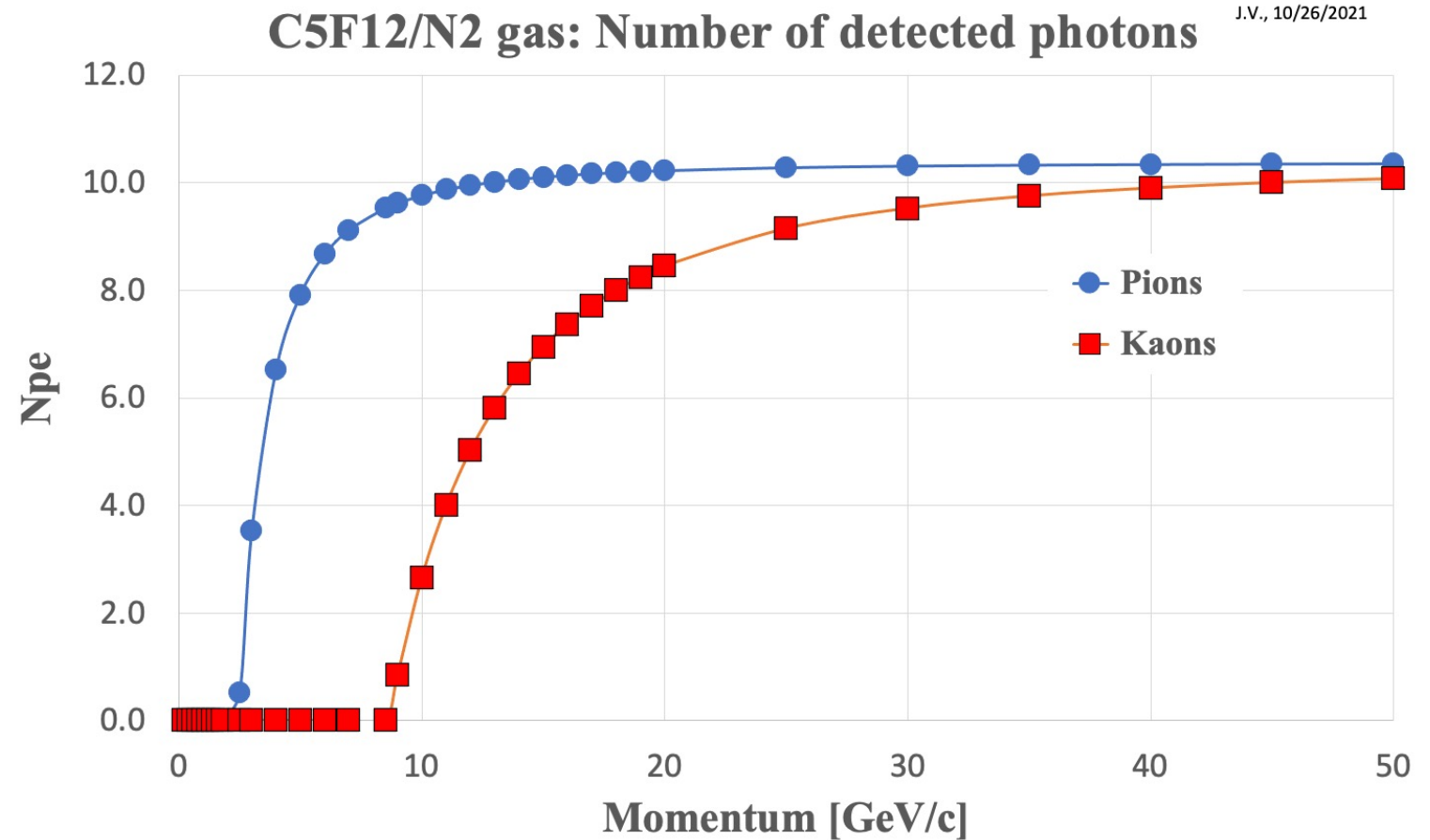

- **Below ~9 GeV/c Kaons do not produce light, Pions below ~2.5 GeV/c.**
- **Between 10 and 15 GeV/c Kaons produce small number of photoelectrons.**

# SiD: Threshold behavior (25 cm)

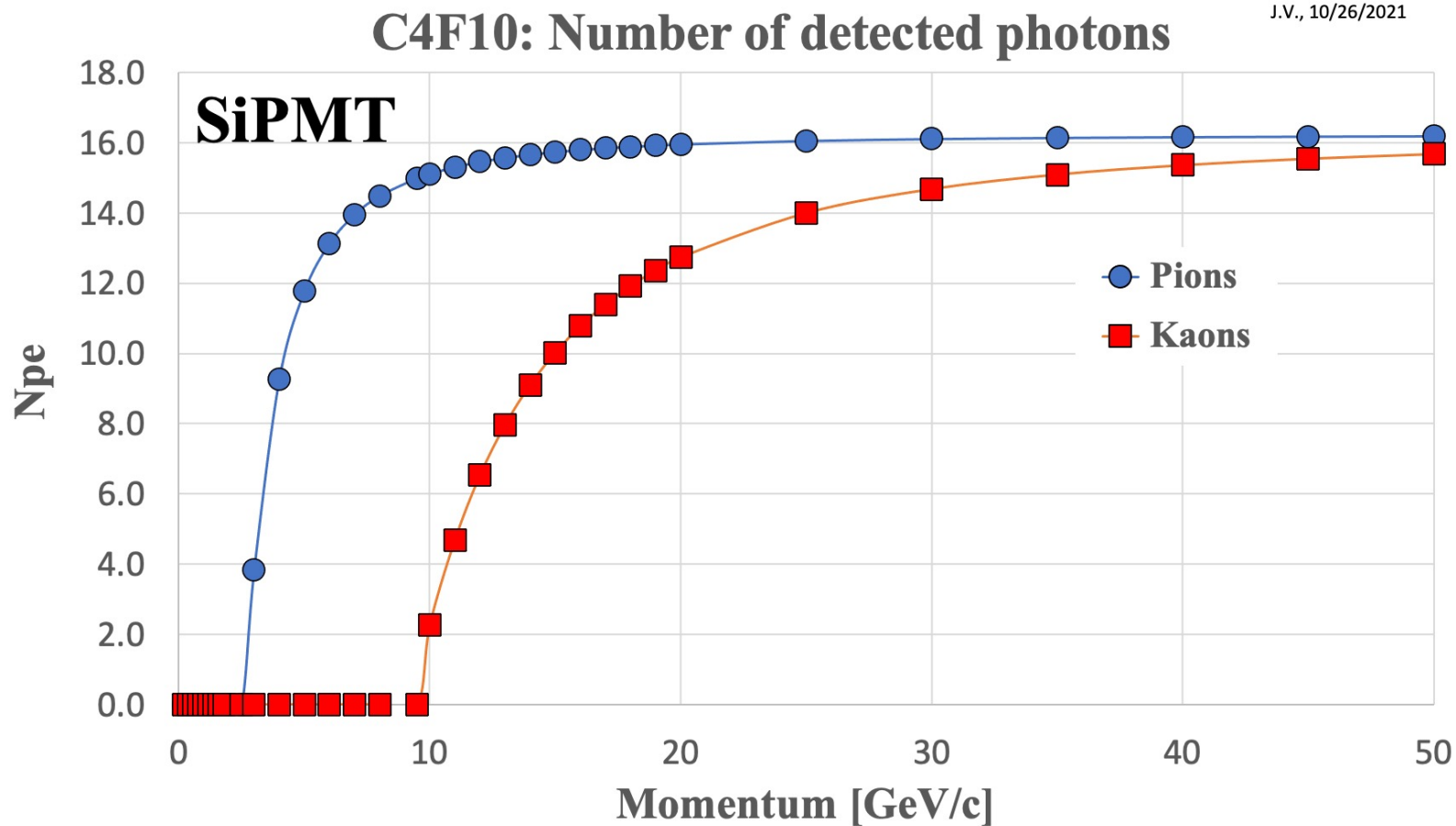

- Below 10 GeV/c Kaons do not produce light in this gas, Pions below ~3 GeV/c.

# SiD: PID performance = f(momentum, B)

J.V., 11/3/2021

# of sigmas =

$$\frac{\theta_{\pi} - \theta_K}{\sigma_{\theta} / \sqrt{N}}$$

$\sigma_{\theta}$  is total Cherenkov angle resolution

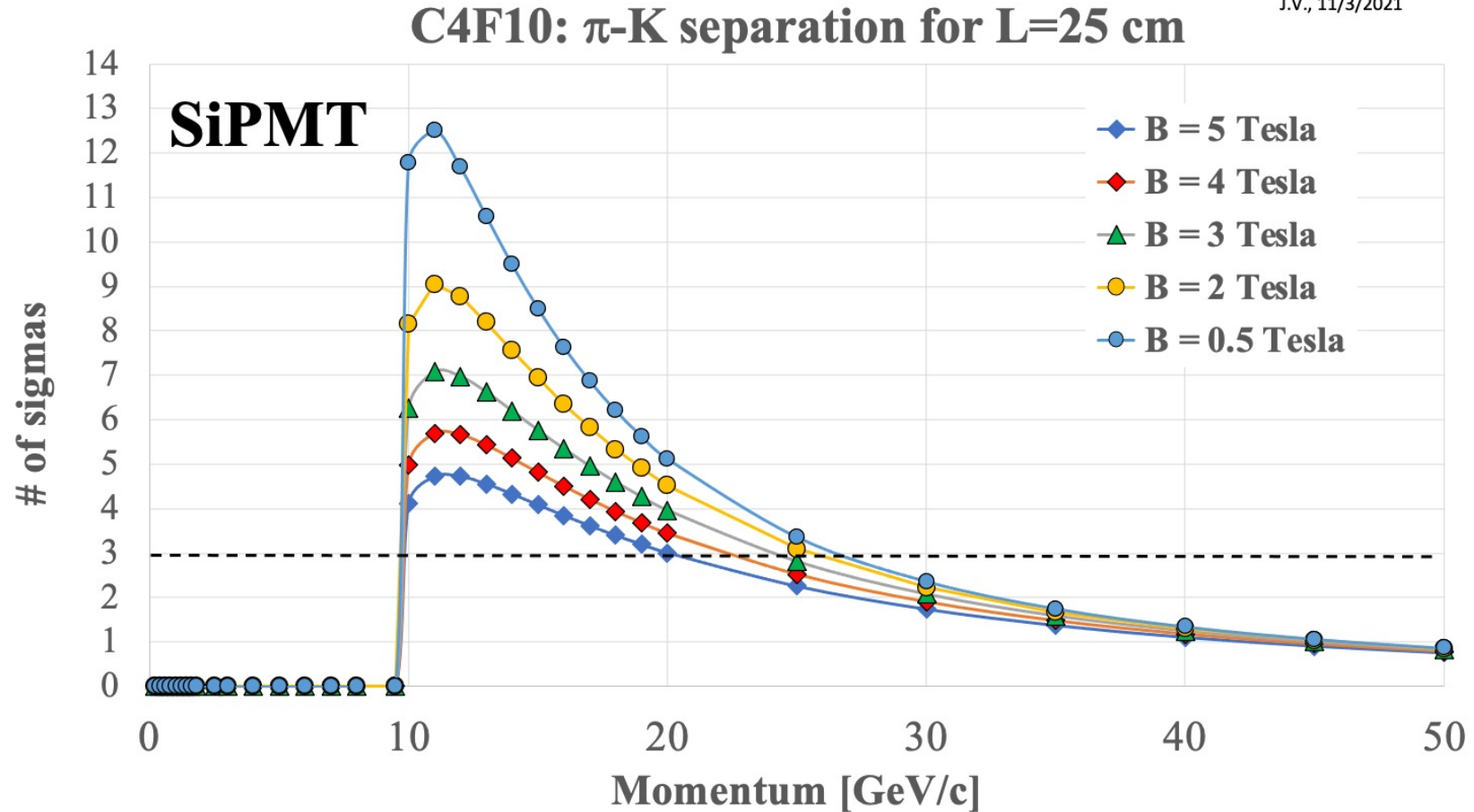

- **Maximum field we might think about in this particular design is 3 Tesla.**

# SiD: PID performance = $f(\text{momentum}, \sigma_\theta)$

J.V., 10/25/2021

### C4F10: $\pi$ -K separation for L=25 cm

# of sigmas =

$$\frac{\theta_\pi - \theta_K}{\sigma_\theta / \sqrt{N}}$$

$\sigma_\theta$  is total Cherenkov angle resolution

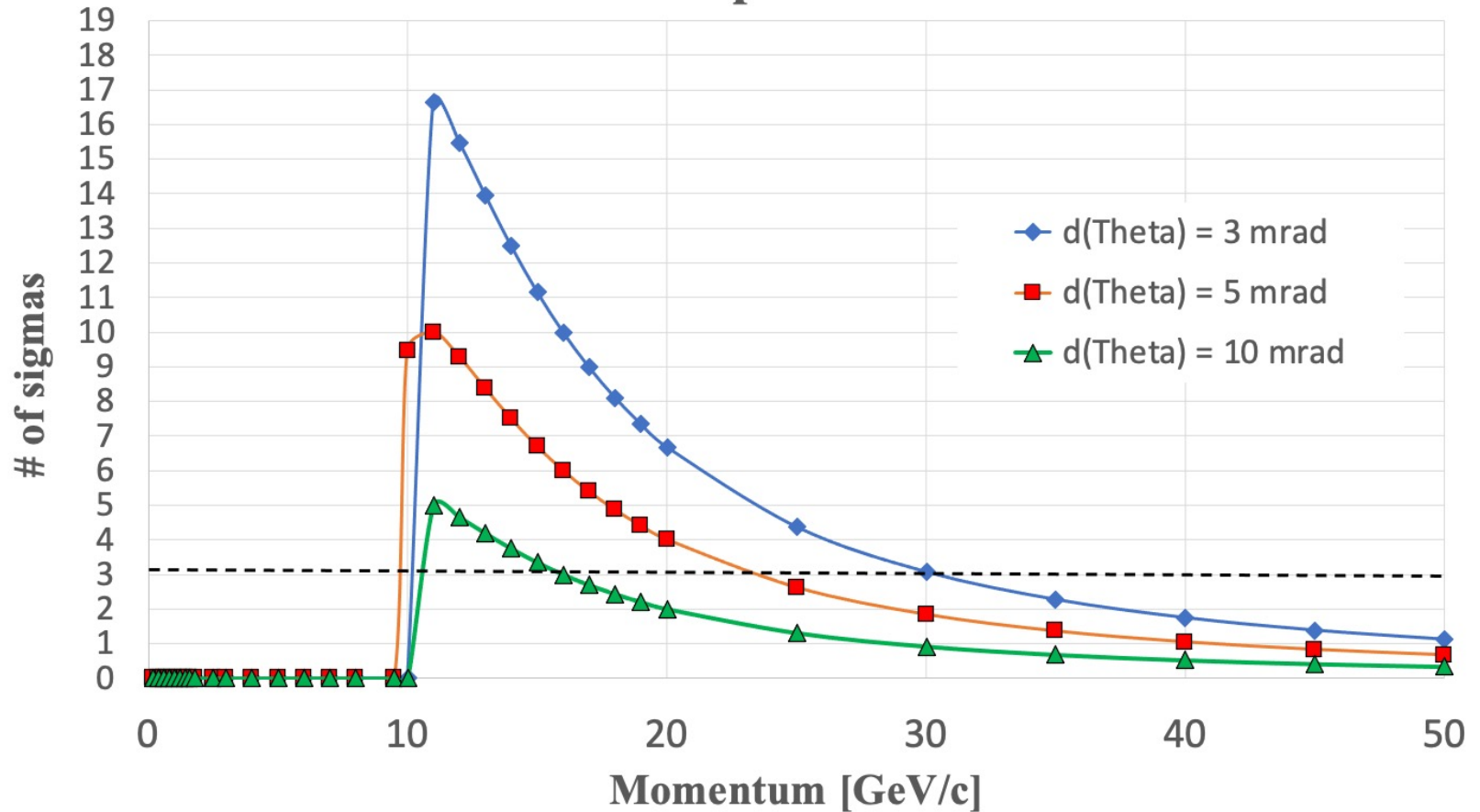

- **Goal: One should not exceed Cherenkov error above ~5 mrad !!**

# SiD: Threshold behavior

J.V., 11/6/2021

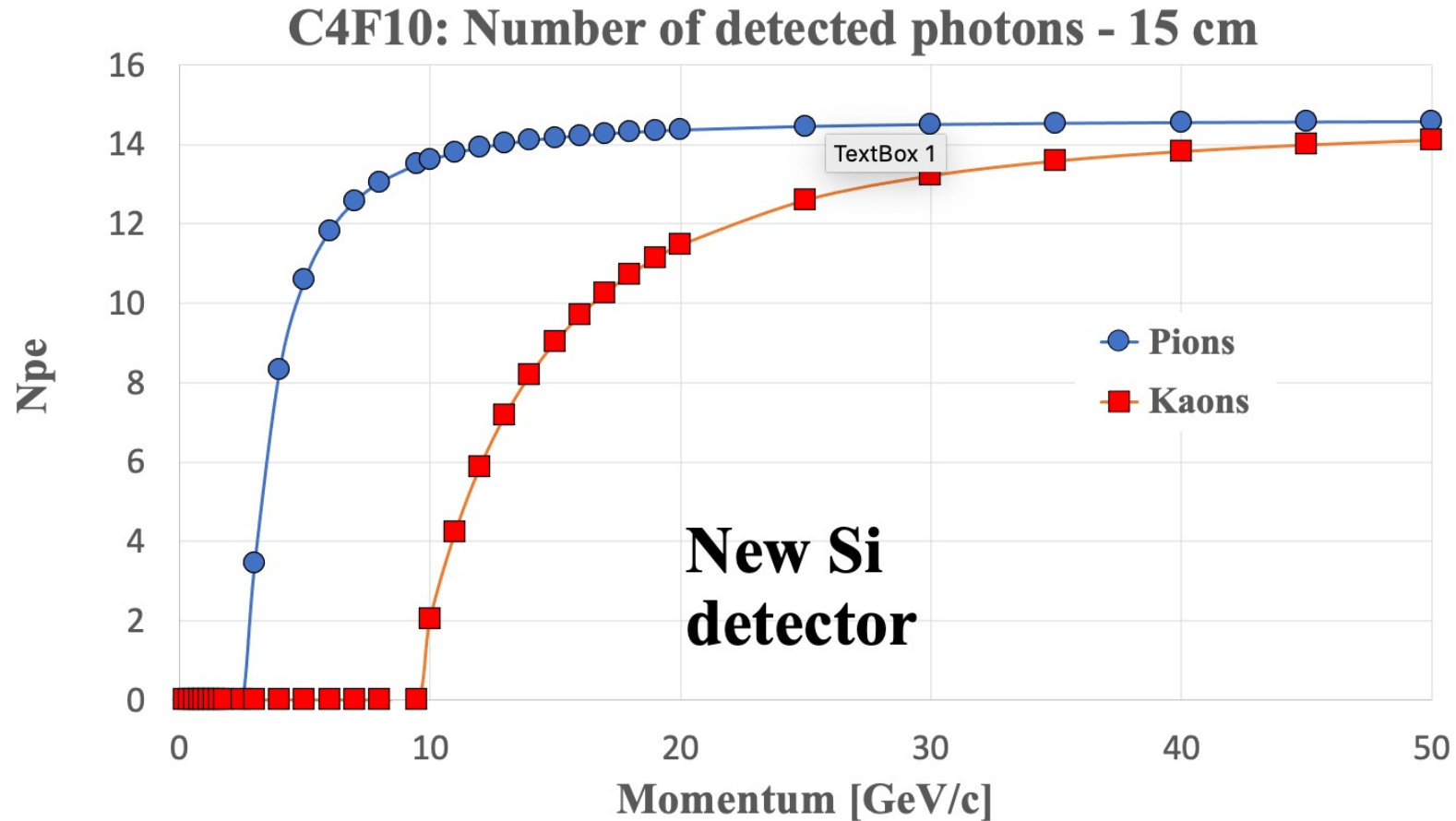

- 15 cm long radiator; PDE of a hypothetical Si detector has  $1.5 \times \text{PDE}_{\text{SiPMT}}$ .

# SiD: PID performance = f(momentum, B)

J.V., 11/6/2021

C4F10:  $\pi$ -K separation for L=15 cm

# of sigmas =

$$\frac{\theta_{\pi} - \theta_K}{\sigma_{\theta} / \sqrt{N}}$$

$\sigma_{\theta}$  is total Cherenkov angle resolution

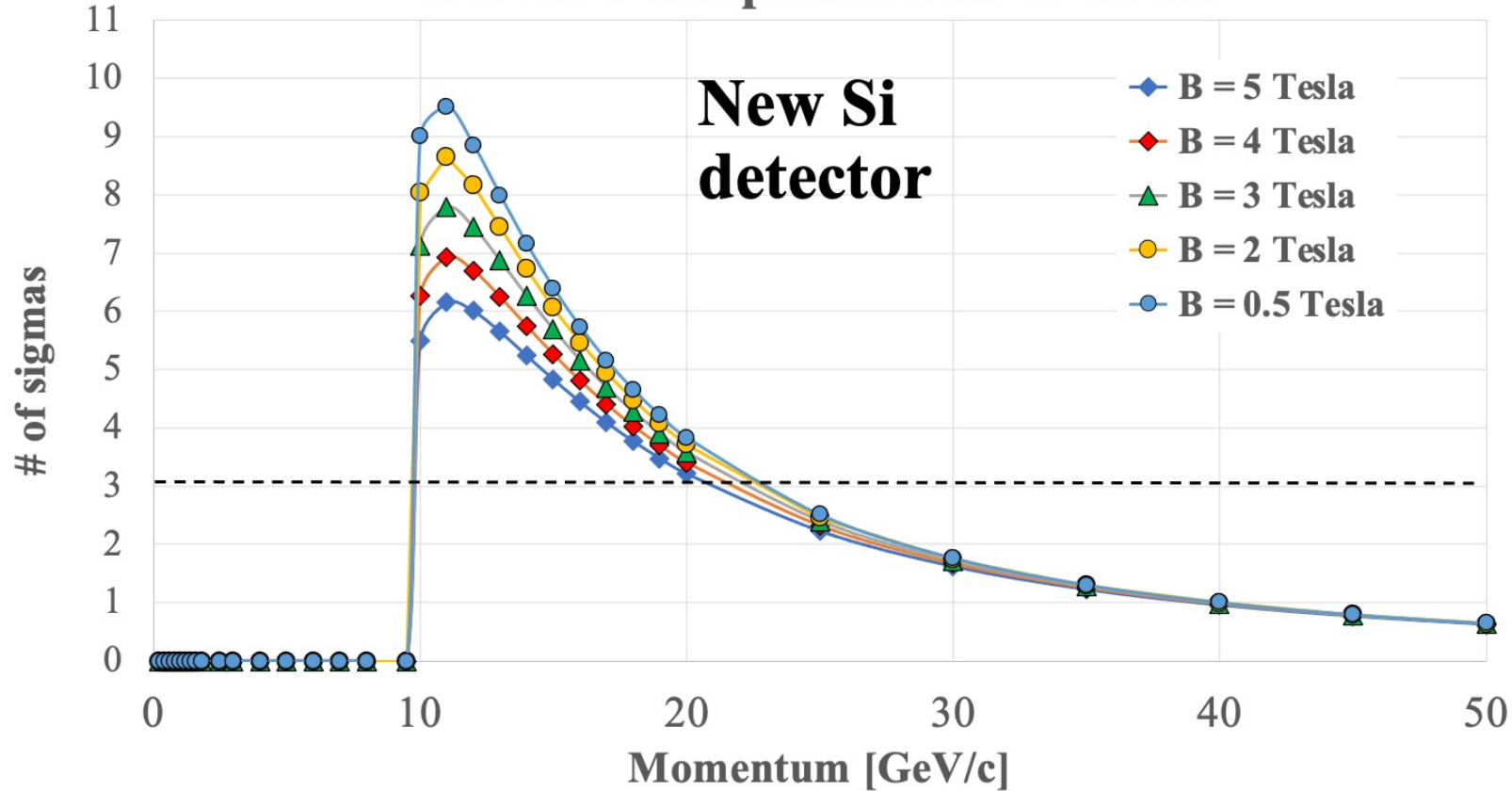

- 15 cm long radiator; PDE of a hypothetical Si detector has 1.5 x PDE<sub>SiPMT</sub>.
- This detector does not exist yet.

# SiD: Threshold behavior

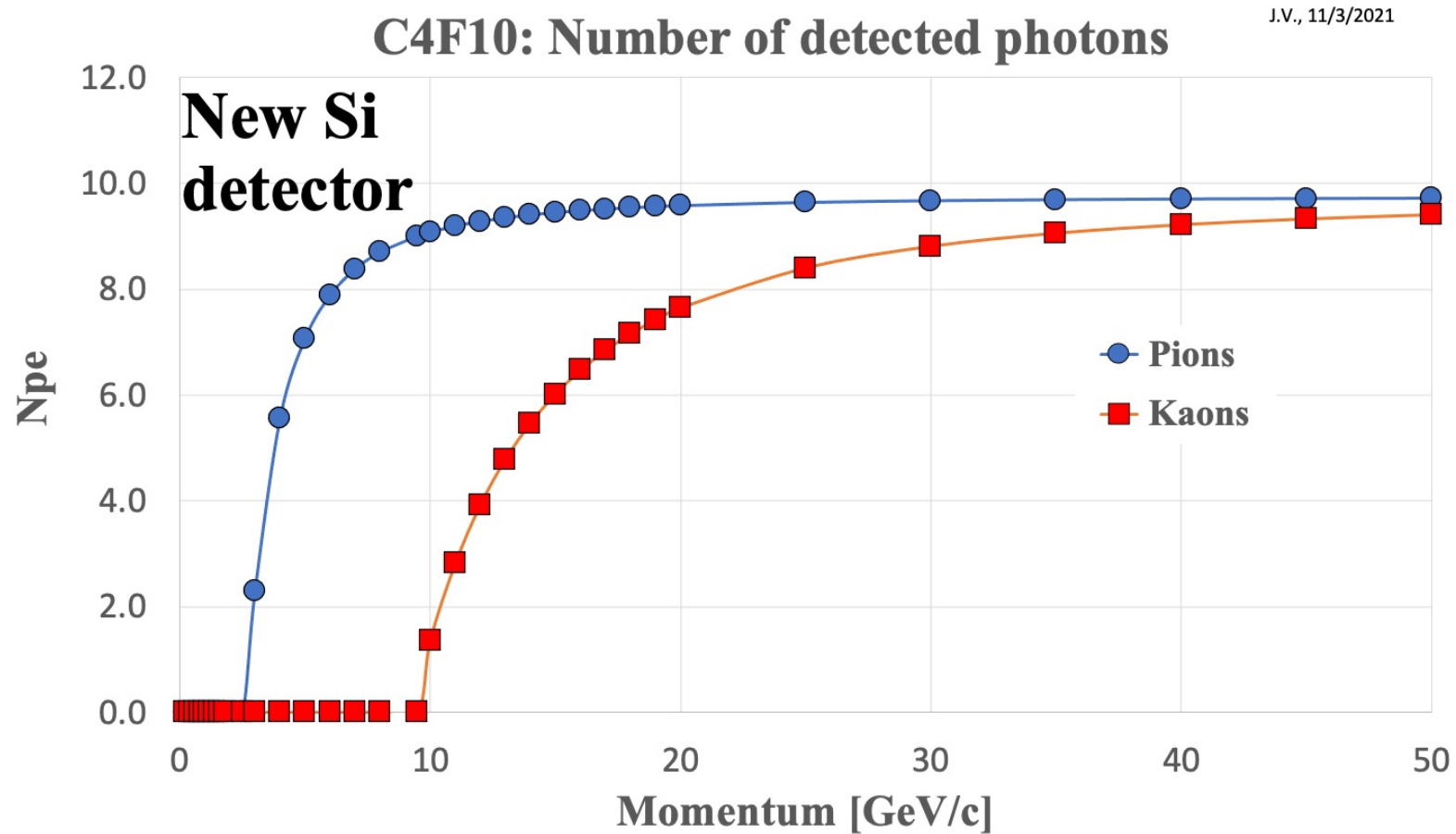

- 10 cm long radiator; PDE of a hypothetical Si detector has  $1.5 \times \text{PDE}_{\text{SiPMT}}$ .

# SiD: PID performance = f(momentum, B)

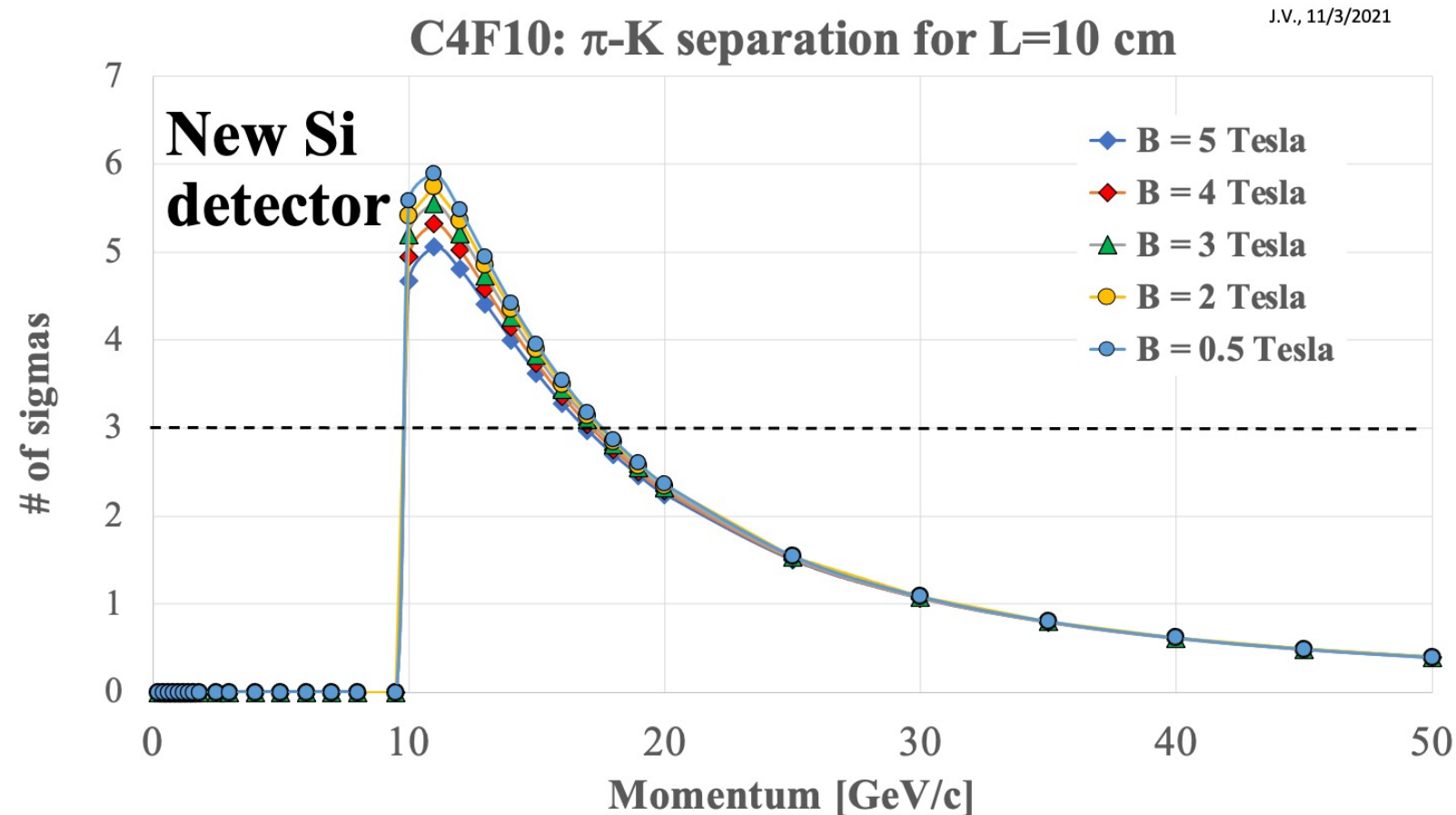

- 10 cm long radiator; PDE of a hypothetical Si detector has  $1.5 \times \text{PDE}_{\text{SiPMT}}$ .
- Not good enough + This detector does not exist yet.