



Probing Physics of Inflation and Neutrino properties with CMB measurements

W.L. Kimmy Wu
KICP Fellow
University of Chicago / Kavli
Institute for Cosmological Physics

Feb 13, 2019
SLAC Colloquium

Outline

- ❖ Inflation and cosmic microwave background (CMB) polarization
- ❖ The BICEP/Keck Array and South Pole Telescope (SPT)
- ❖ Improving constraints of inflation from BICEP/Keck through “delensing”
 - ❖ Lensing measurements from SPT + neutrino mass
 - ❖ Neural network approaches
- ❖ The Future: from BICEP/Keck + SPT to CMB-S4

Some of the biggest questions in cosmology today

- ❖ What is dark matter?
- ❖ What is dark energy?
- ❖ What are the properties of neutrinos?
- ❖ What is the physics of inflation?

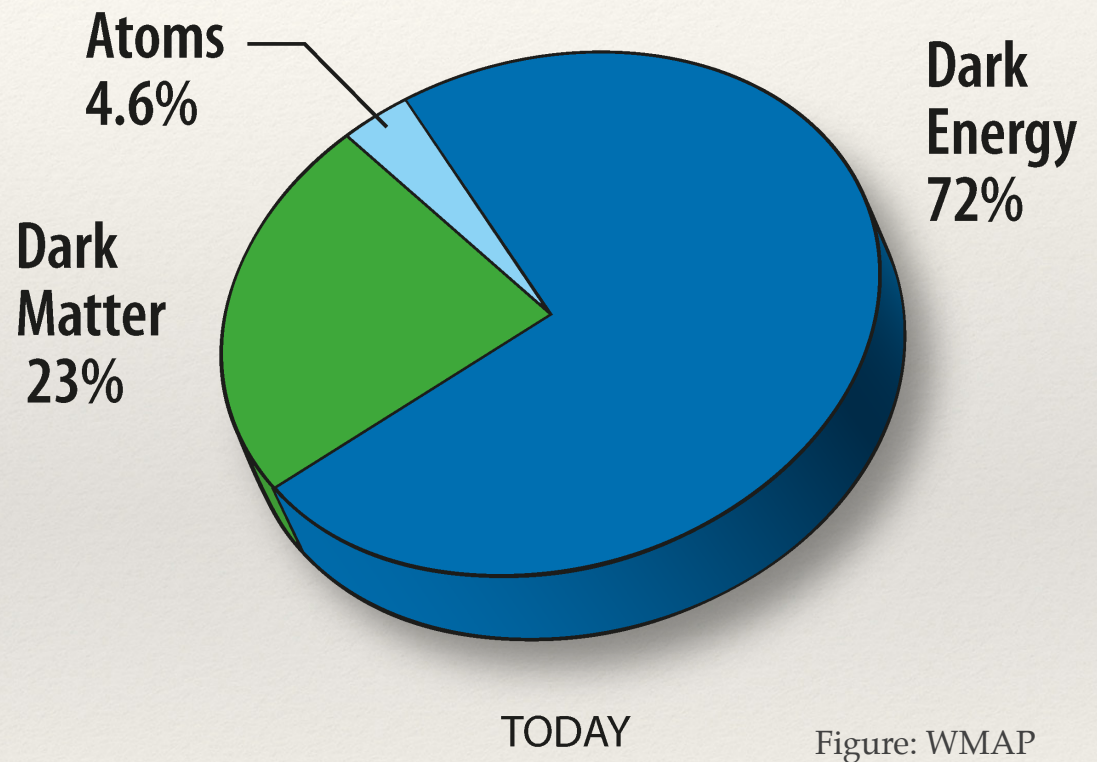

Inflation

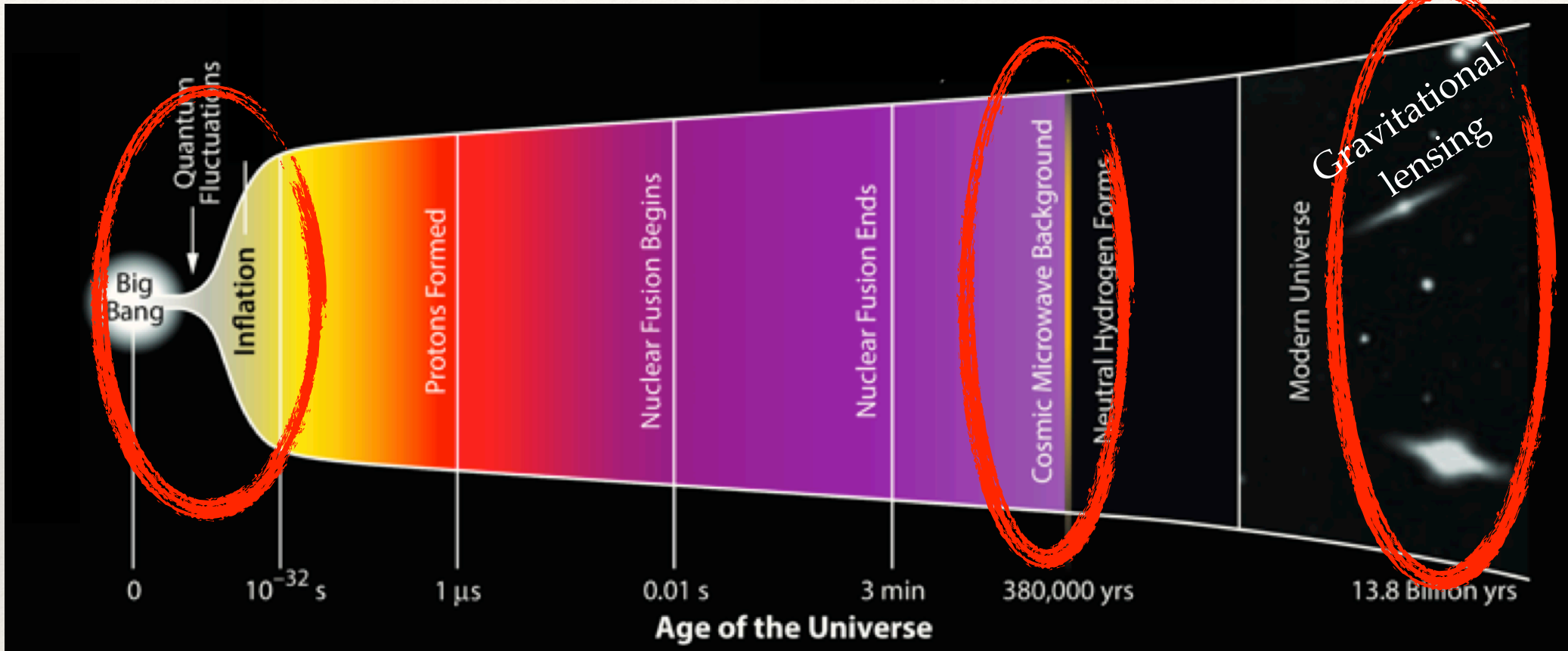

- near-exponential expansion within a fraction of a second
- solves conceptual problems with hot big bang

Observational Signatures of Inflation

tensor perturbations

scalar perturbations

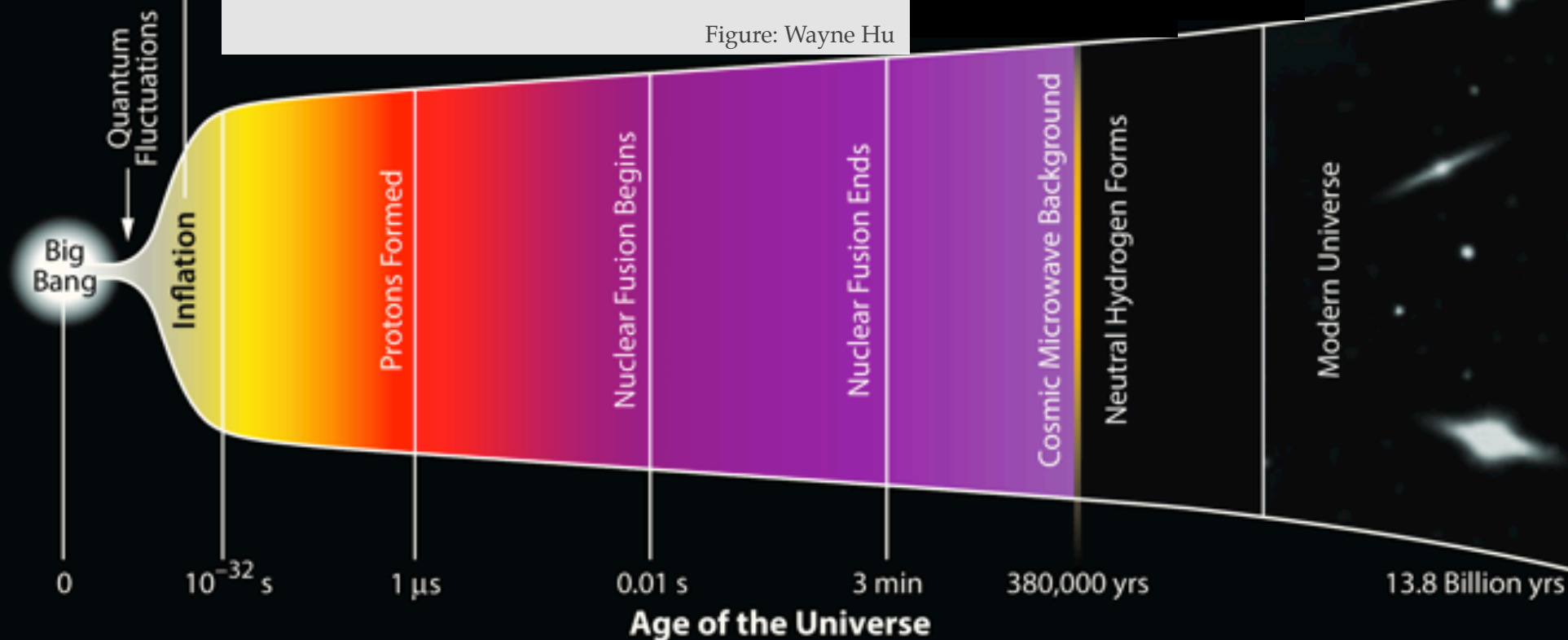
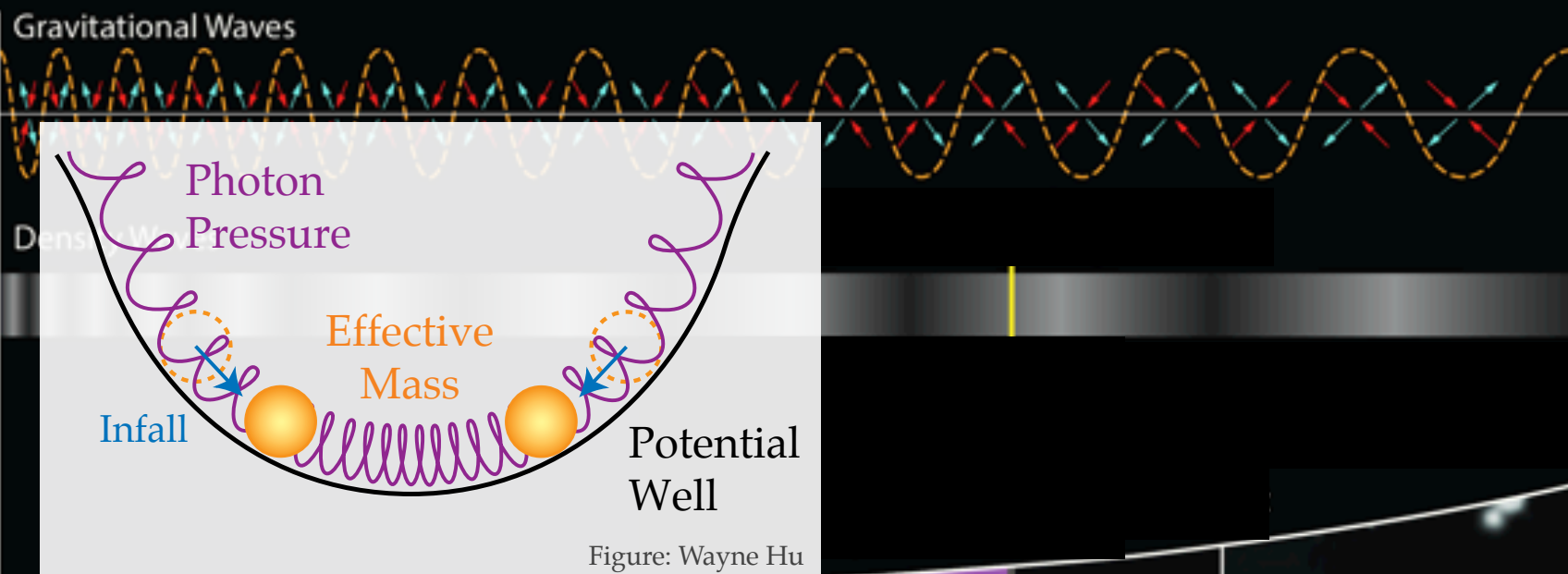

Polarization requires quadrupole anisotropy

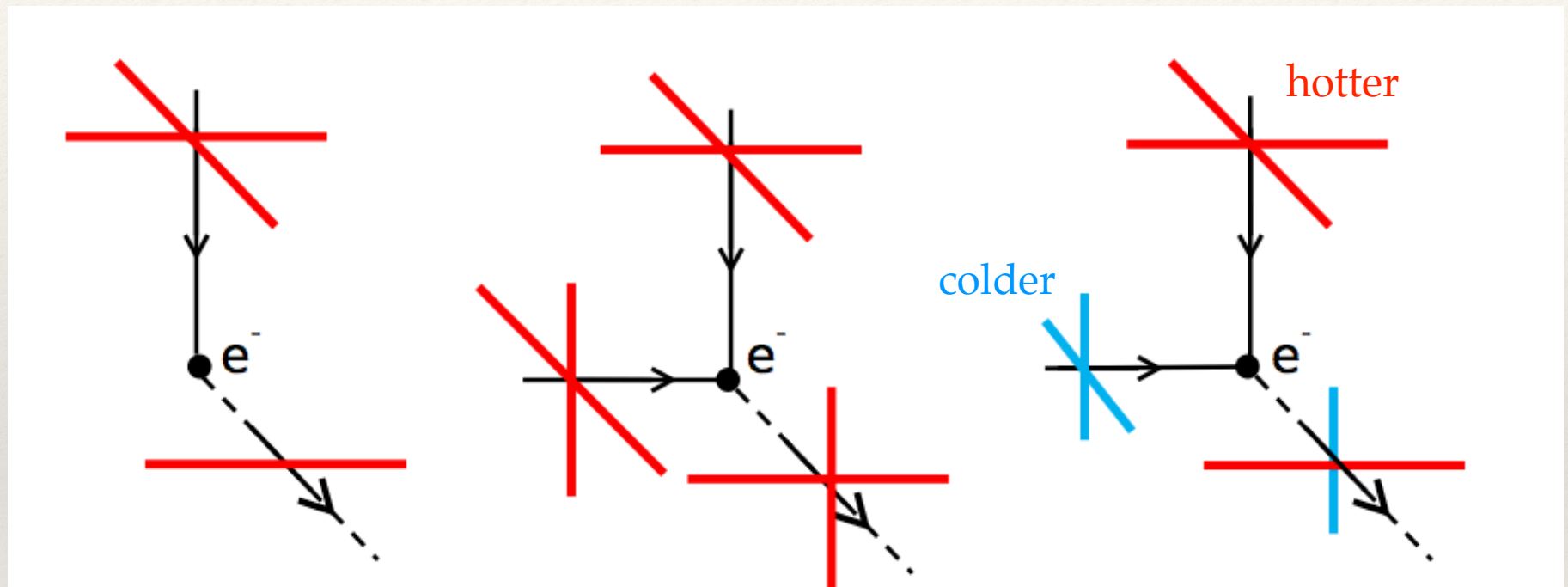

Thomson scattering

Density waves: quadrupole temperature anisotropy

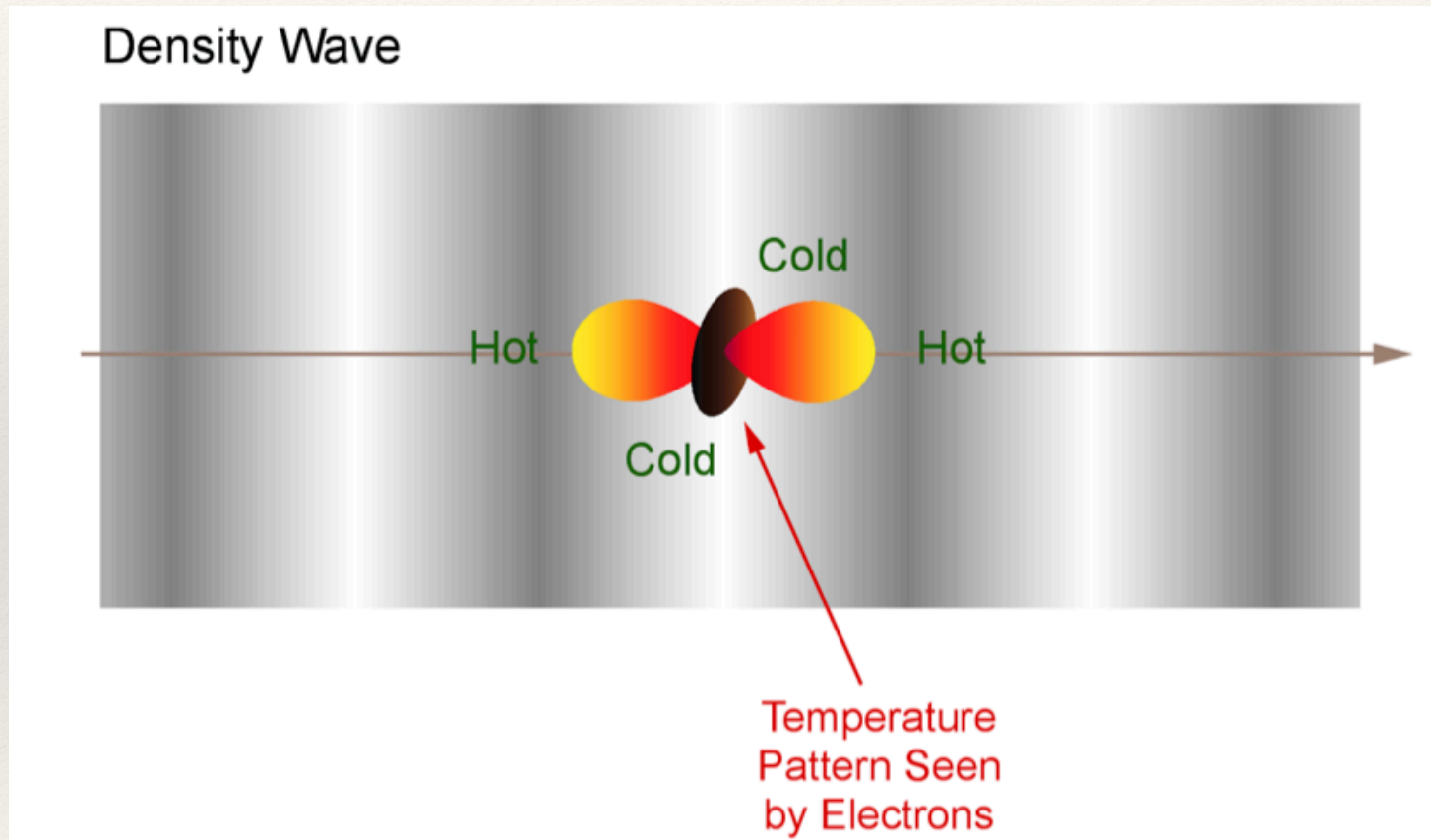

Gravitational waves: quadrupole temperature anisotropy

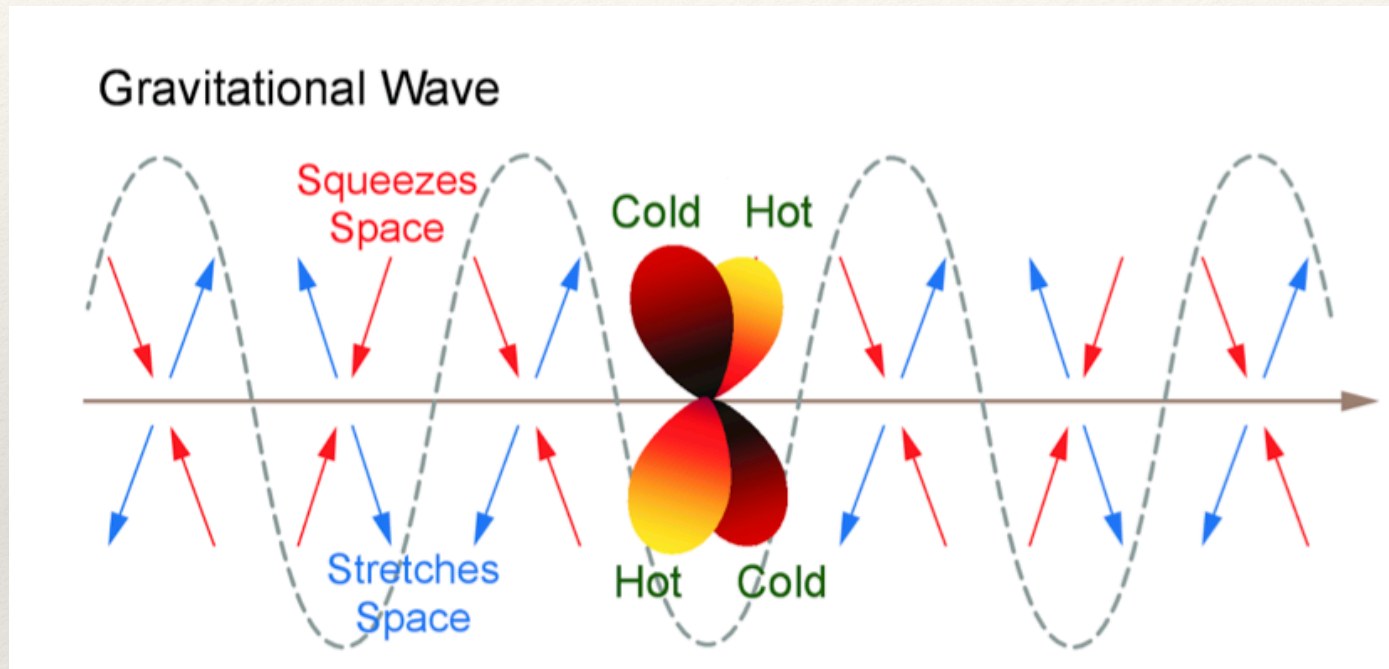

CMB Polarization

Density Wave

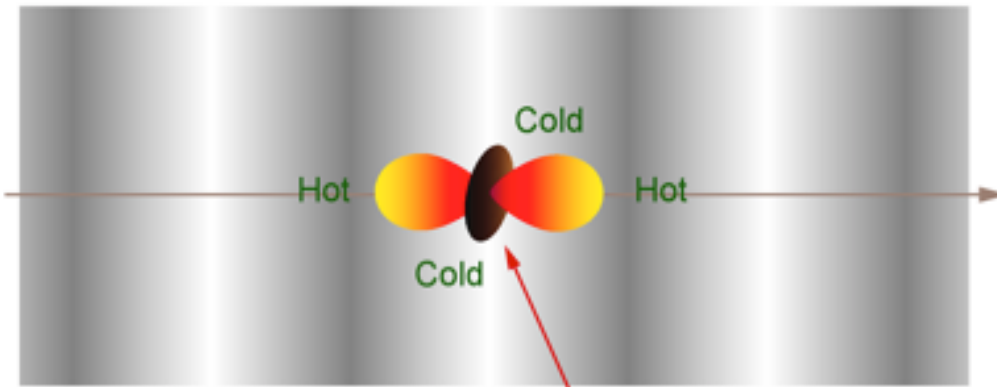

Temperature Pattern Seen by Electrons

Gravitational Wave

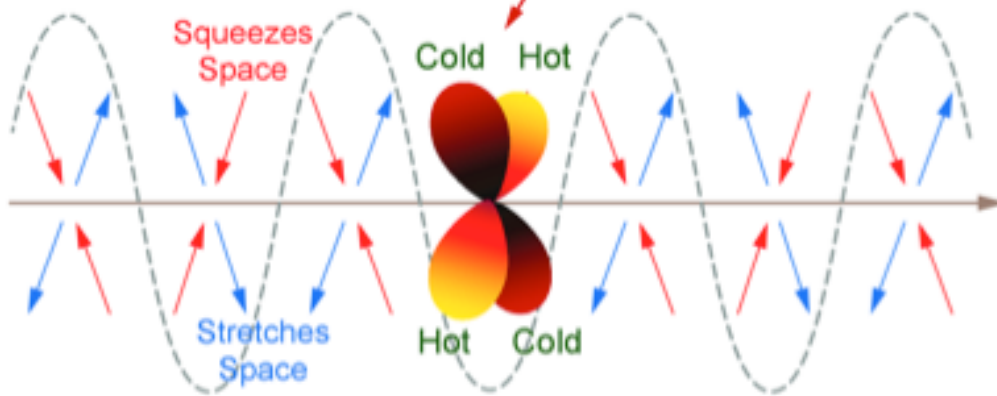

E-Mode Polarization Pattern

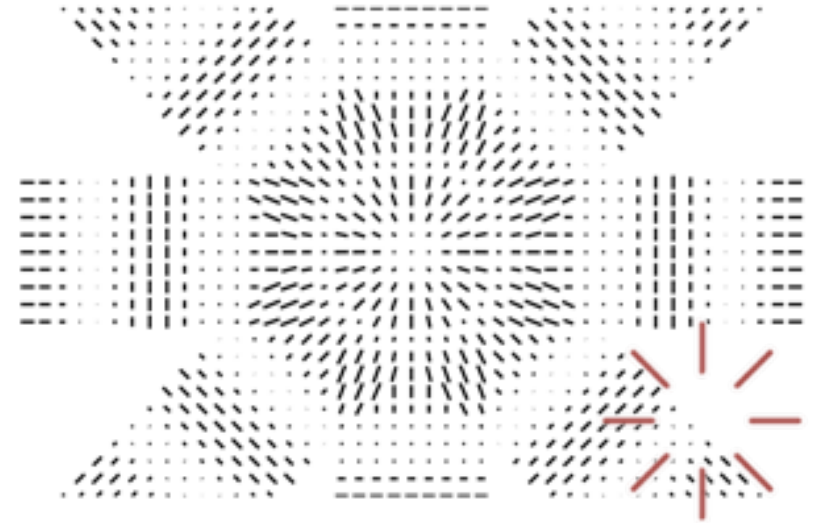

B-Mode Polarization Pattern

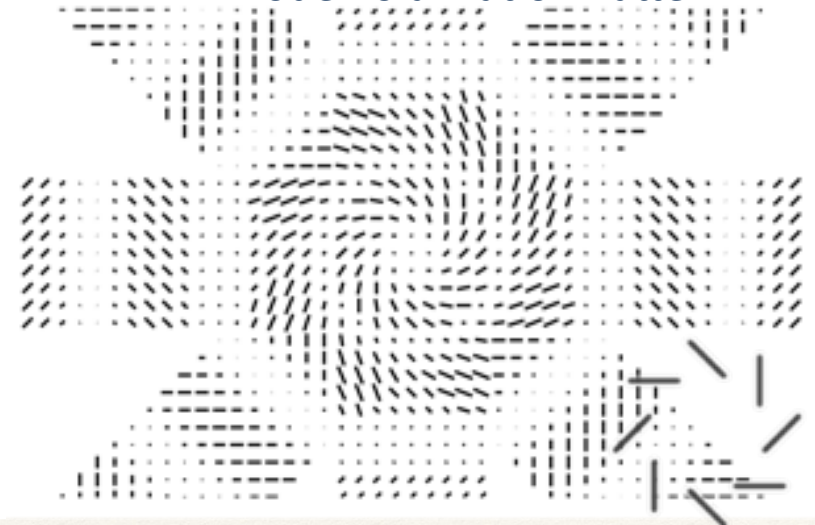

Observational Signatures of Inflation

tensor perturbations

scalar perturbations

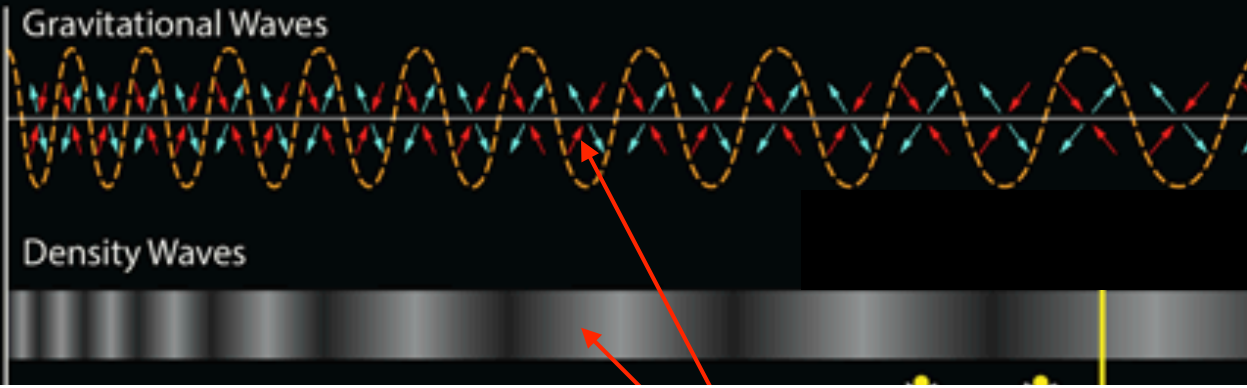

T, E, B

T, E

Radius of the Visible Universe

r

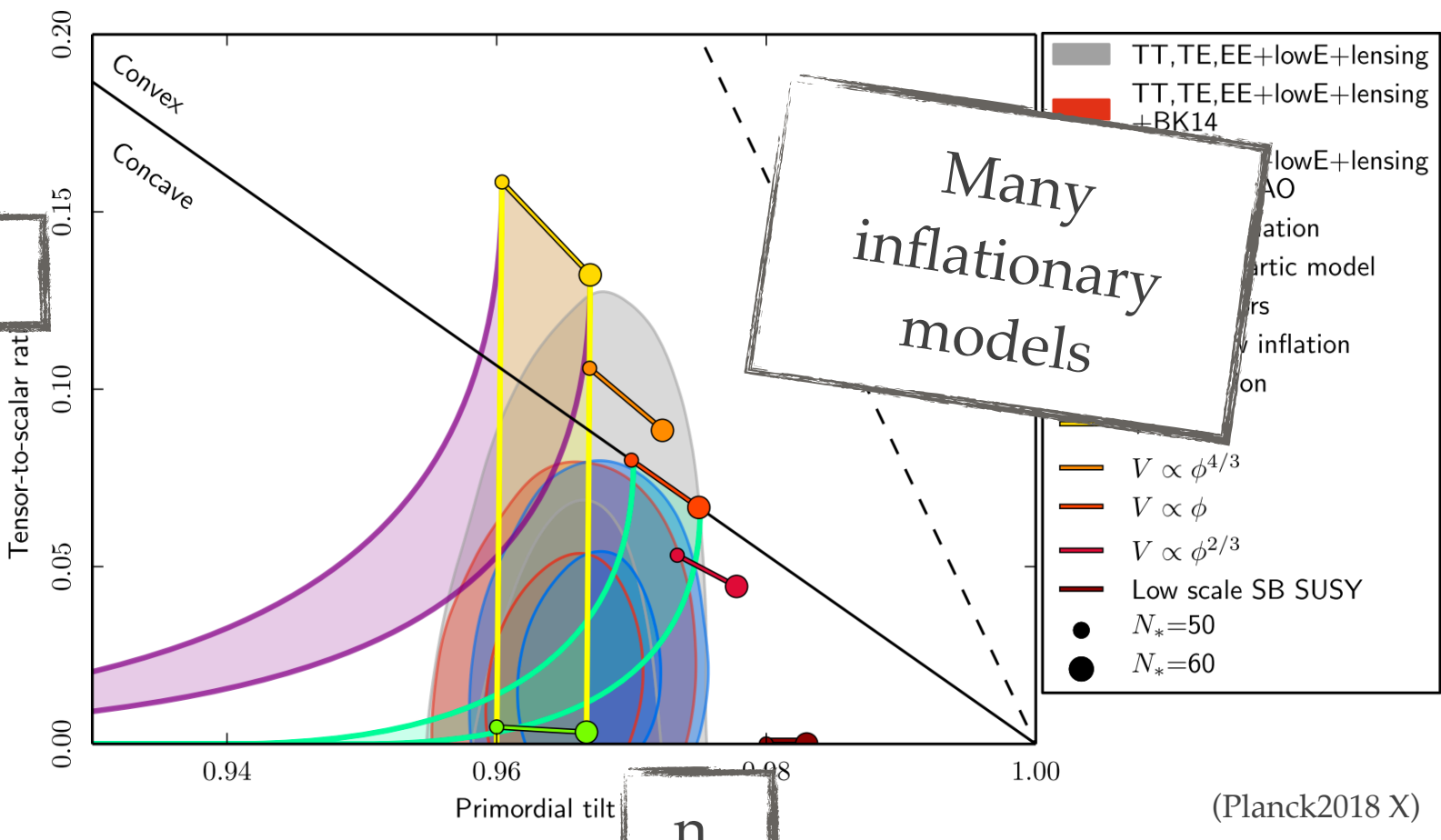

(Planck2018 X)



We are probing the highest energy phenomenon in the universe!

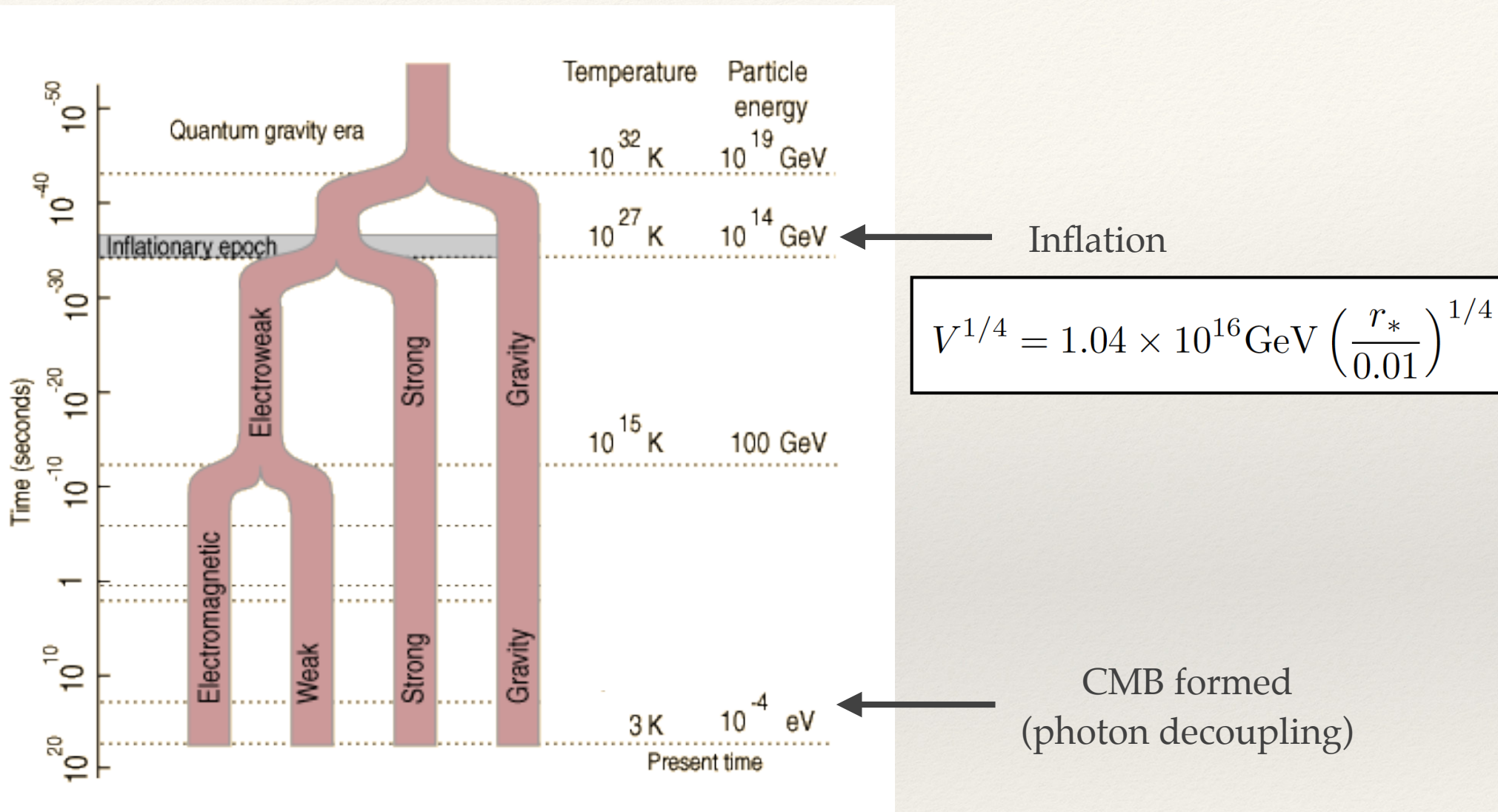
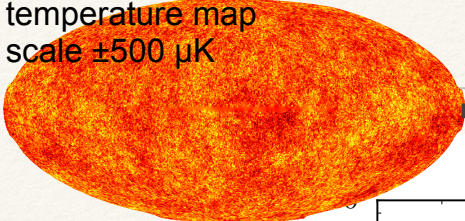
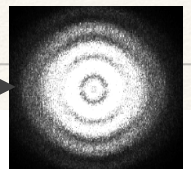

figure: patrickgrant.com

Planck's all sky CMB temperature map
scale $\pm 500 \mu\text{K}$



FT



CMB spectra

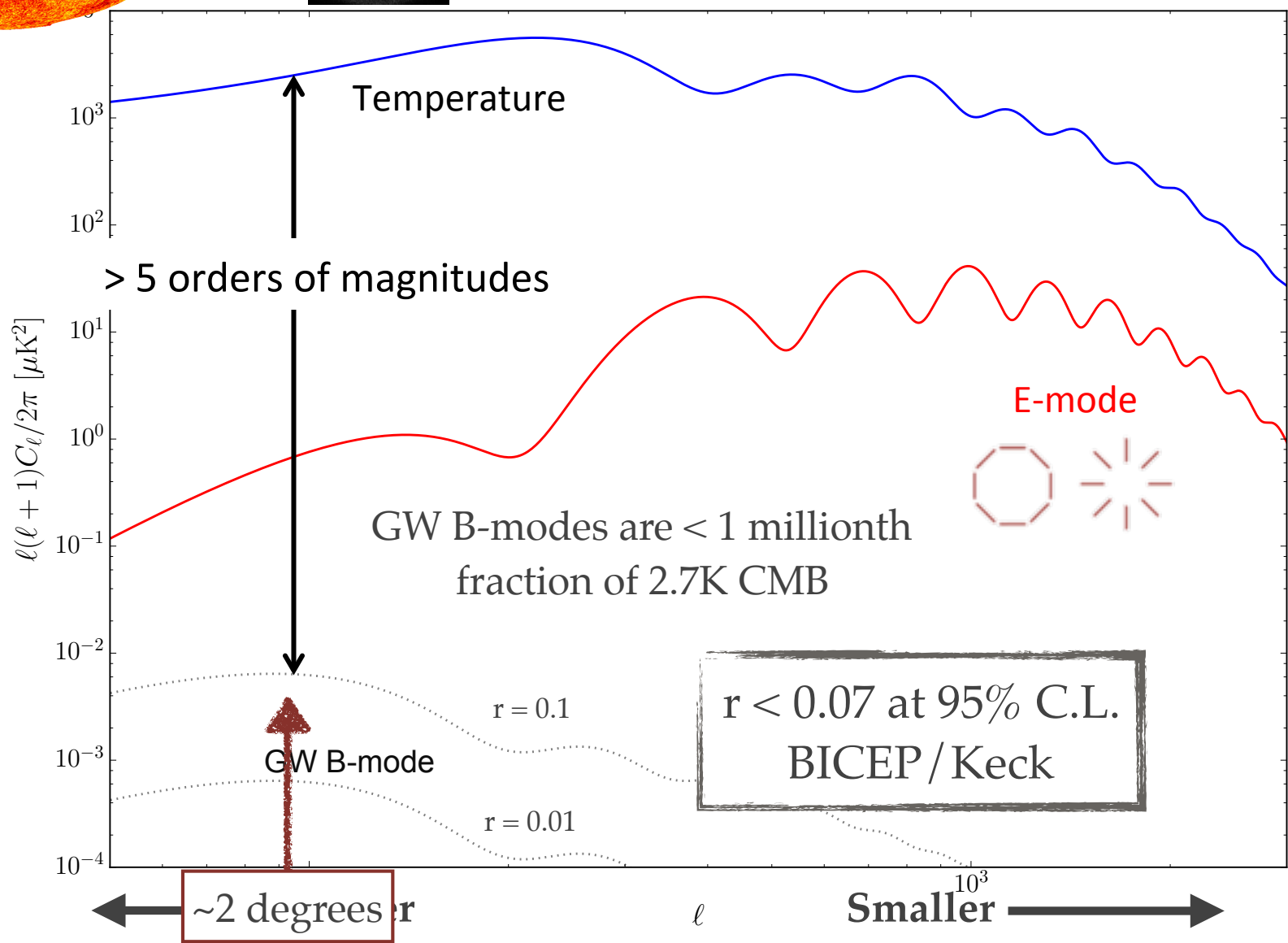

Polarized foregrounds

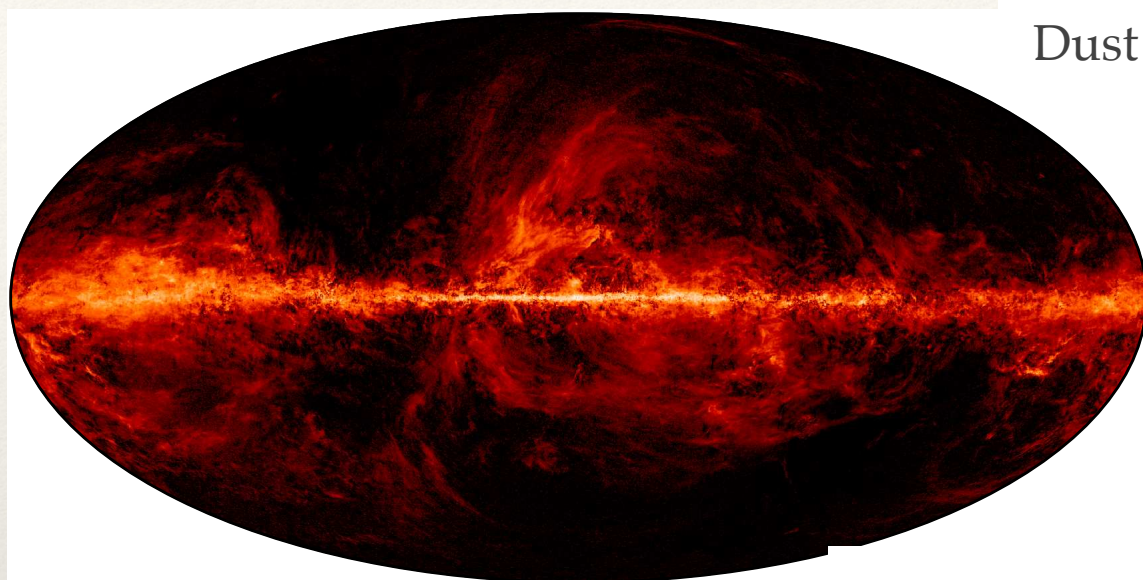

Dust



3

μK_{RJ} at 353 GHz

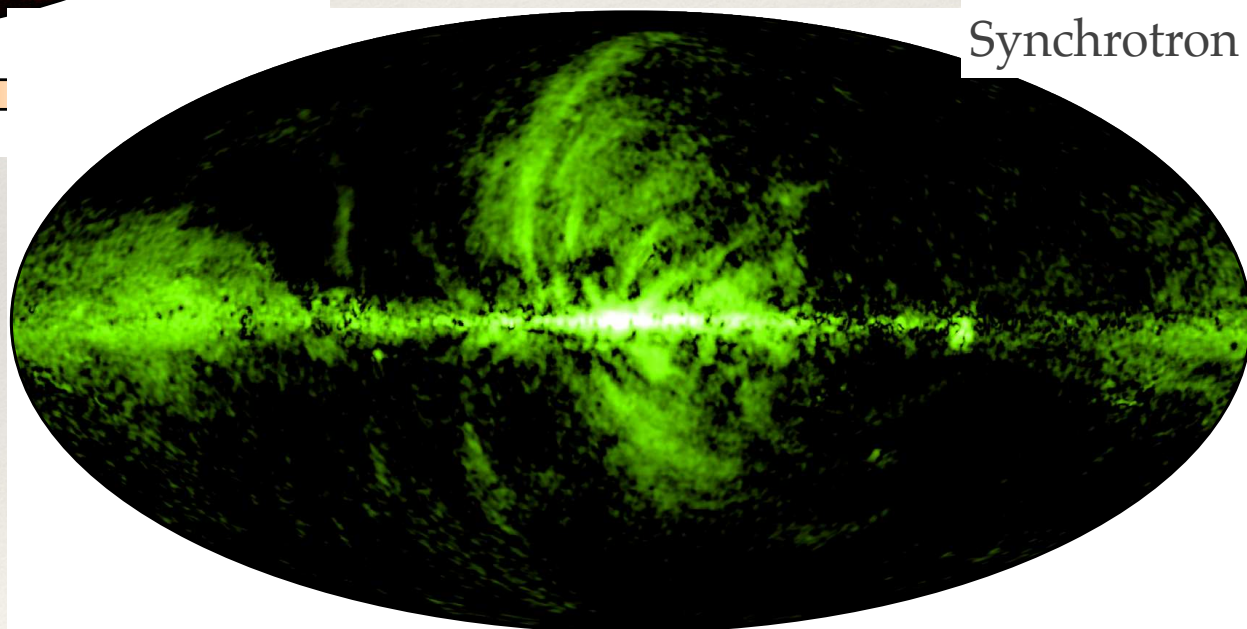

Synchrotron



10

μK_{RJ} at 30 GHz

300

CMB spectra + foregrounds

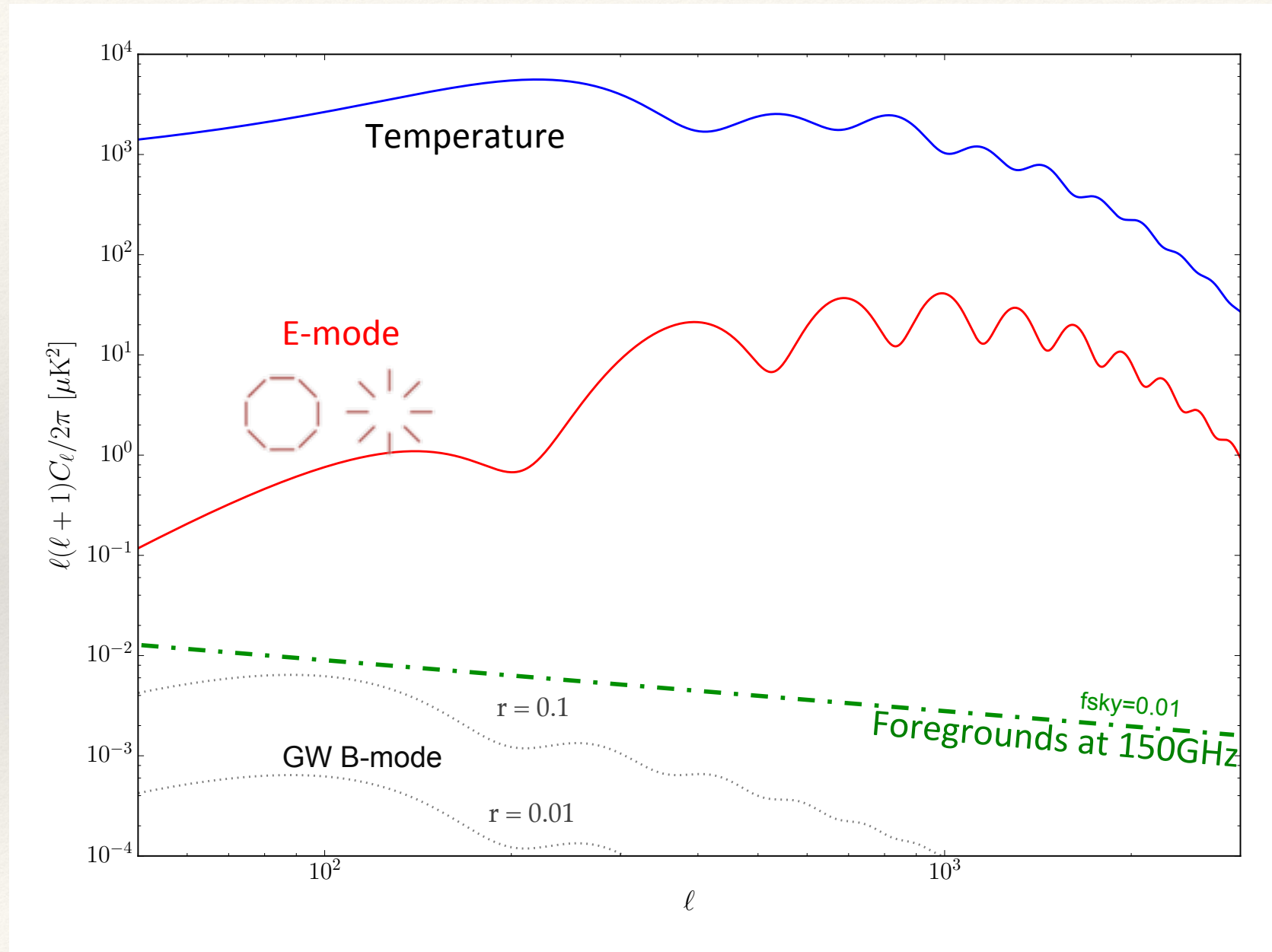

Polarized foregrounds: constrained through multifrequency measurements

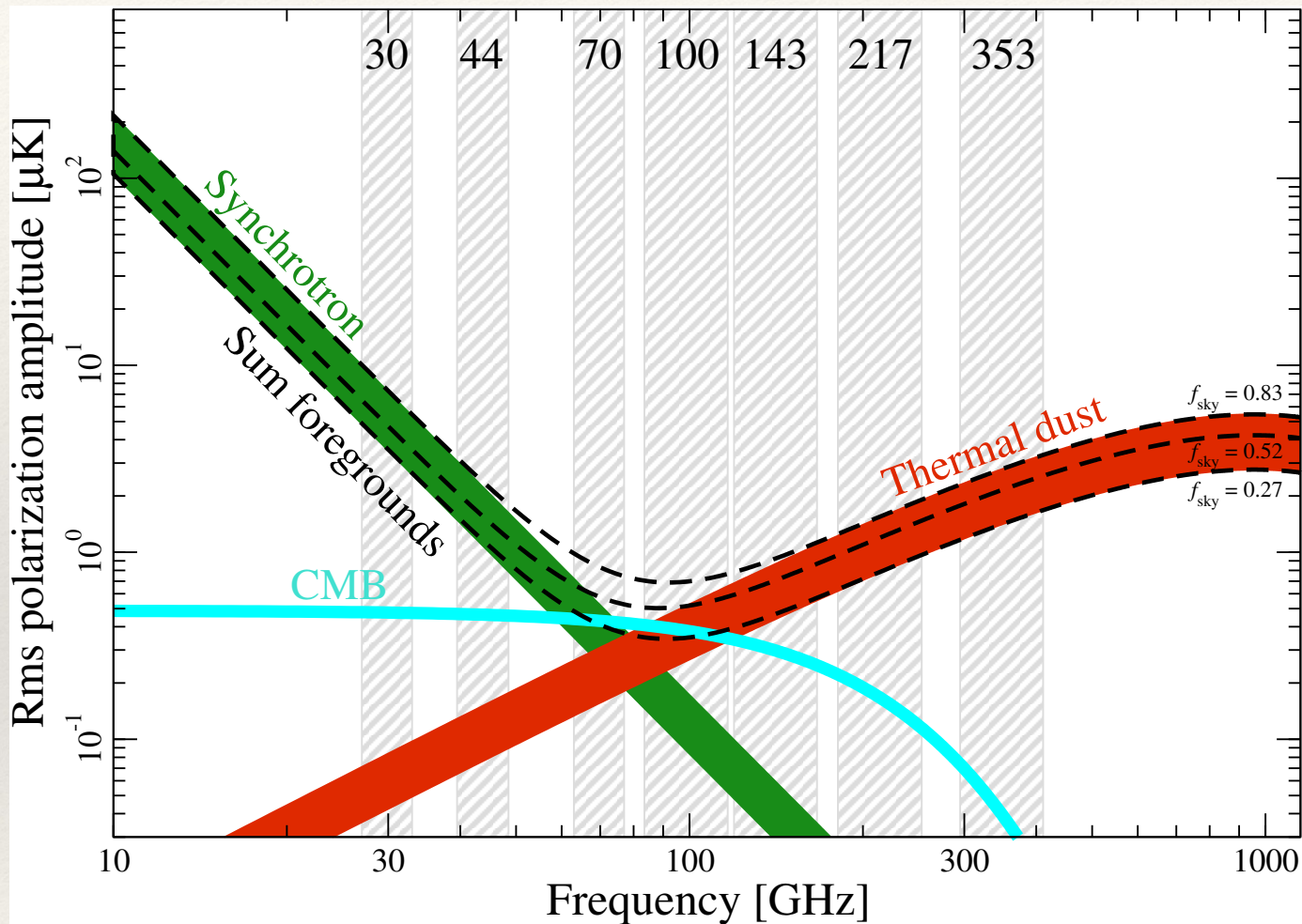

Planck 2018 IV

CMB spectra + foregrounds

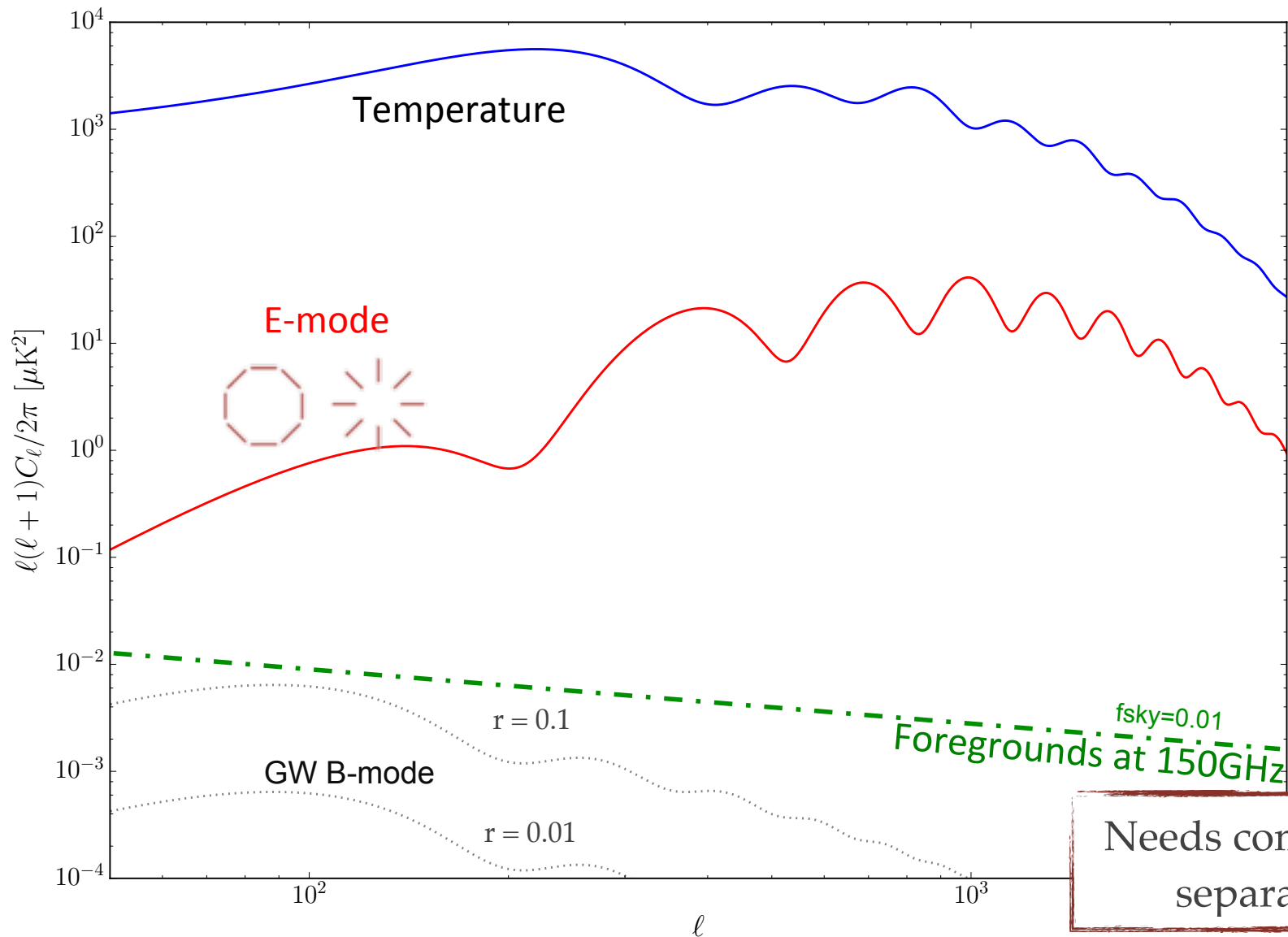

Gravitational lensing as a contaminant: lensing B modes

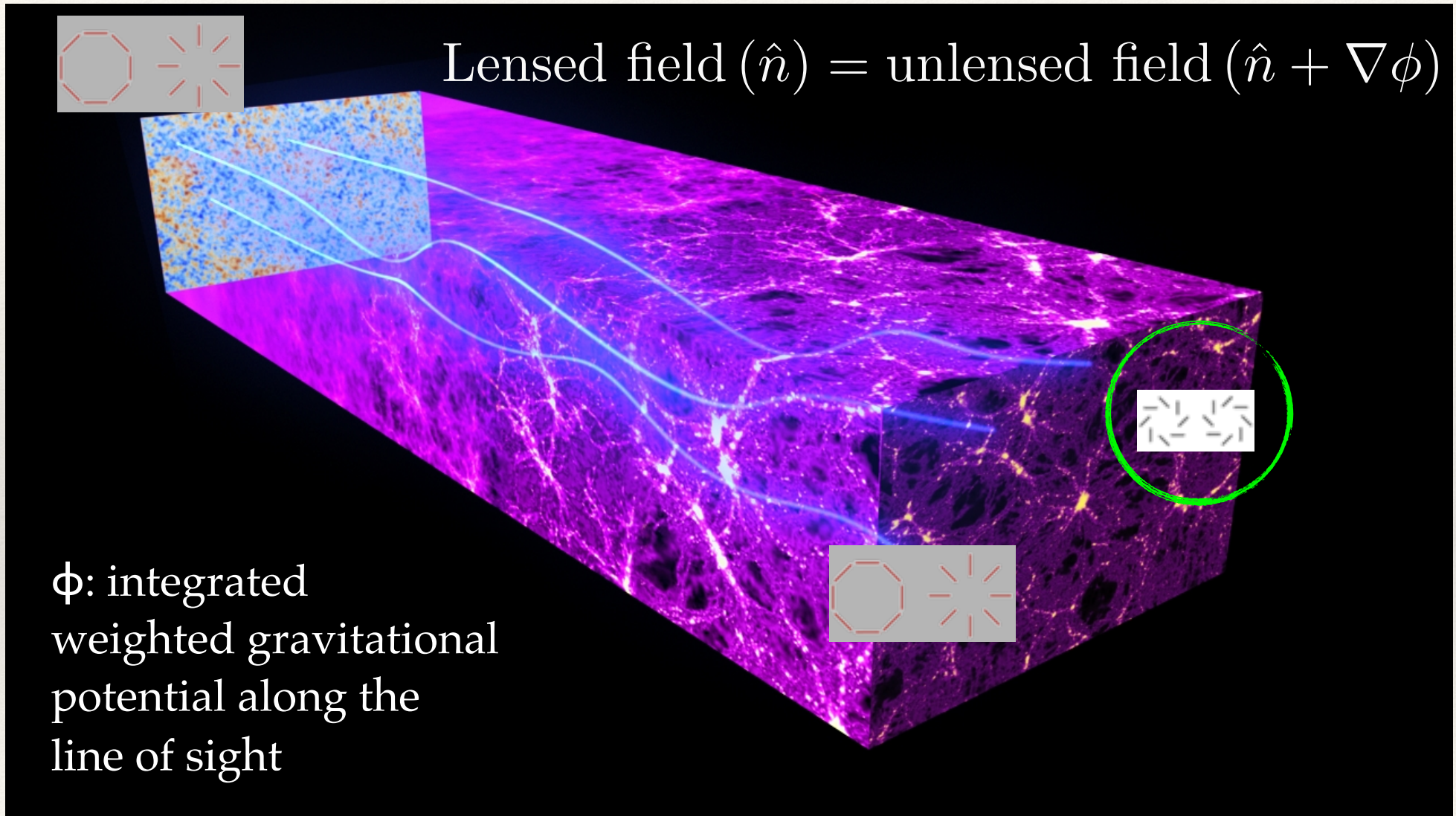

Background image: ESA

$T(\hat{n}) (\pm 350\mu K)$

$E(\hat{n}) (\pm 25\mu K)$

$B(\hat{n}) (\pm 2.5\mu K)$

(no primordial B-modes)

$T(\hat{n}) (\pm 350\mu K)$

$E(\hat{n}) (\pm 25\mu K)$

$B(\hat{n}) (\pm 2.5\mu K)$

(no primordial B-modes)

CMB spectra + foregrounds

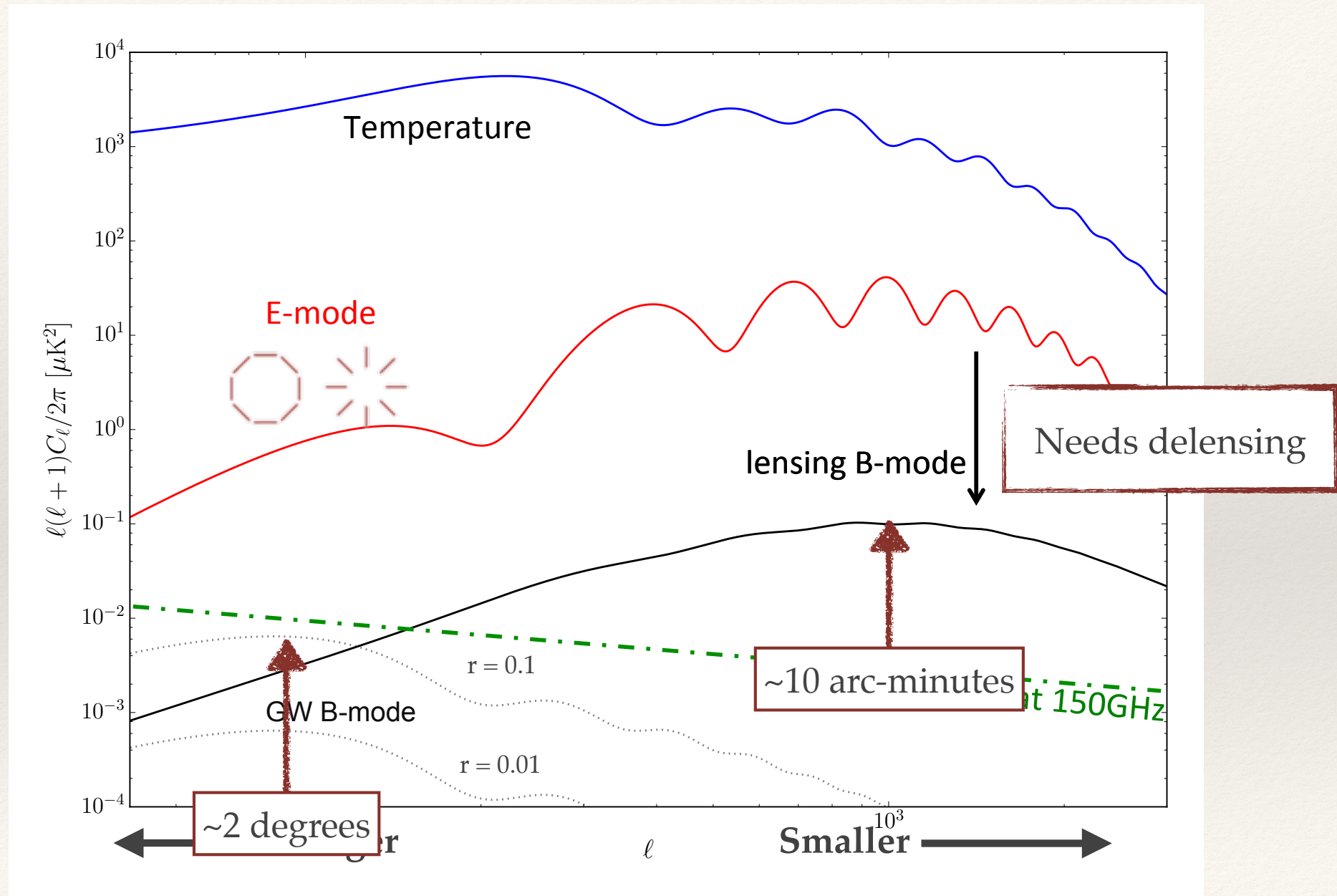

CMB B modes provide a unique window to test the inflationary prediction: existence of primordial gravitational waves.

Primordial B modes are contaminated by galactic foregrounds and lensing B modes —> Need component separation and *delensing*.

Outline

- ❖ Inflation and cosmic microwave background (CMB) polarization
- ❖ The BICEP/Keck Array and South Pole Telescope
- ❖ Improving constraints of inflation from BICEP/Keck through “delensing”
 - ❖ Lensing measurements from SPT + neutrino mass
 - ❖ Neural network approaches
- ❖ Outlook - from BICEP/Keck + SPT to CMB-S4

The South Pole has excellent conditions for mm-wave observations

South Pole
Station

Keck

BICEP3, SPT

- Extremely dry
- High altitude (~10,000 feet)
- Stable atmosphere during its 6-month long night

Telescope and Mount

Stage 2

BICEP2
(2010-2012)

Keck Array
(2012-2019)

small aperture;
1/4 deg resolution
to resolve GW B-mode bump

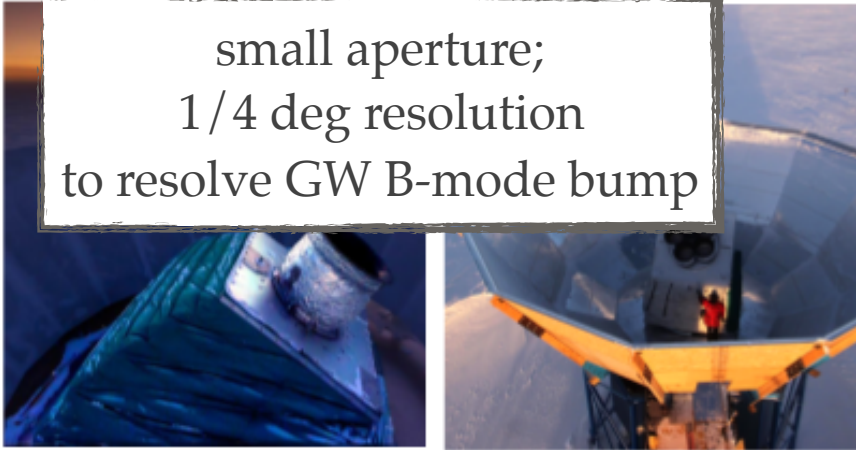

Focal Plane

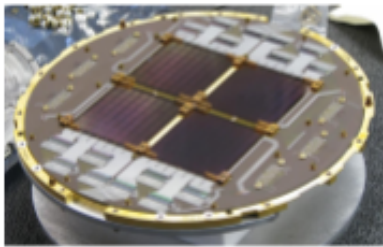

Stage 3

BICEP3

BICEP Array

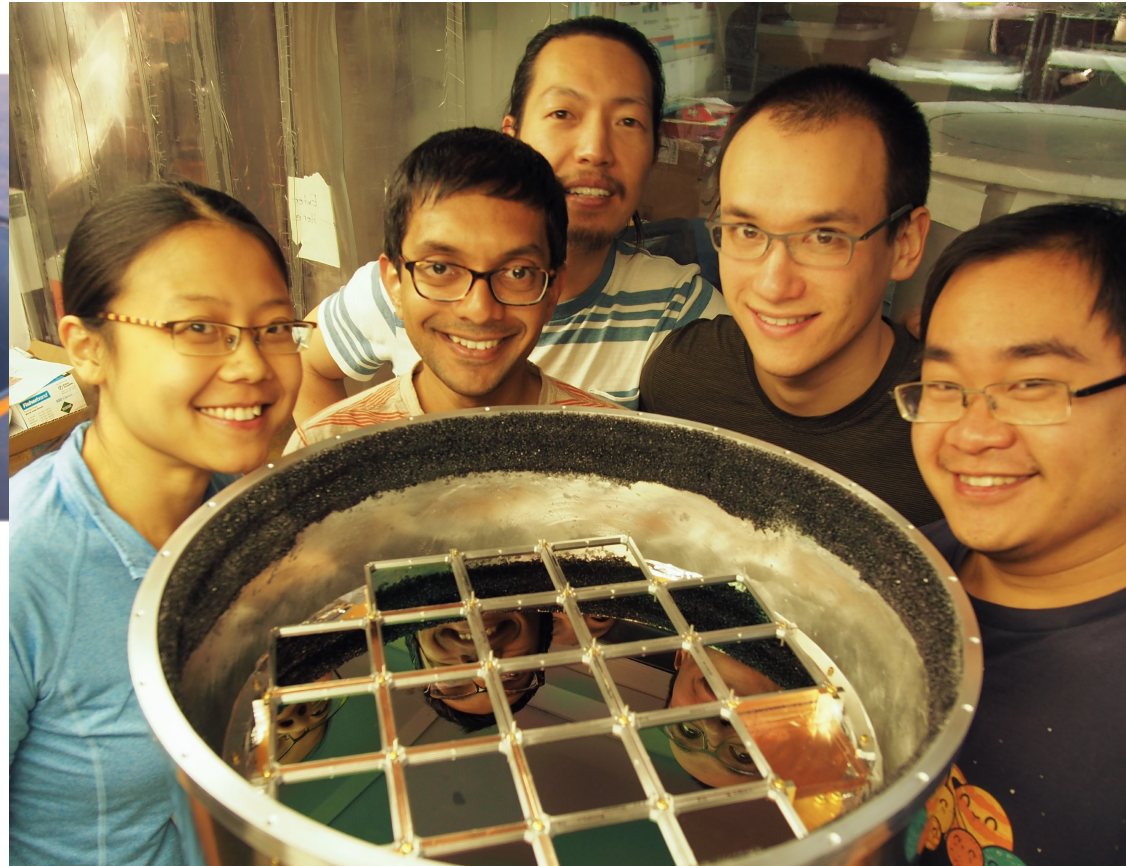

Beams on Sky

multi-frequency for
component separation

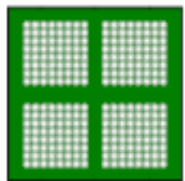

-5 0 5
Degrees on sky

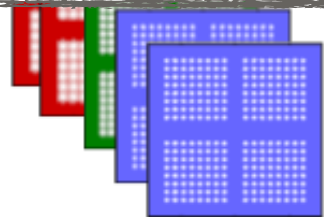

-5 0 5
Degrees on sky

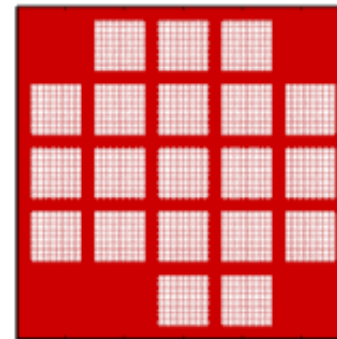

-10 -5 0 5 10
Degrees on sky

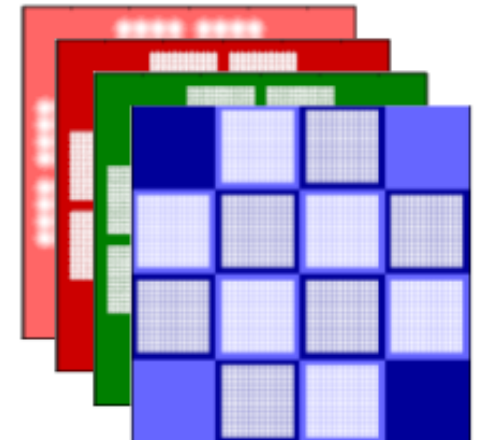

-10 -5 0 5 10
Degrees on sky

South Pole Telescope

SPTpol focal plane
(2012-2016)

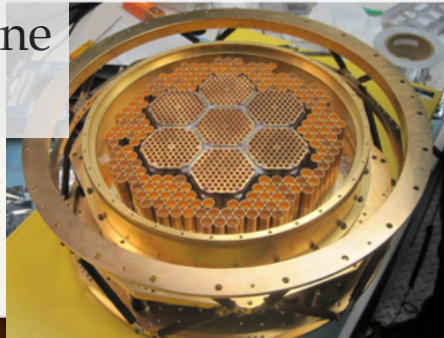

SPT-3G focal plane
(2017-)

- ❖ Highest resolution CMB Telescope (1').
- ❖ Produced the largest deep CMB polarization maps in sub-degree scales
- ❖ Current camera (SPT-3G) has the largest number of detectors in a single receiver.



Planck
143 GHz
50 deg²



The moon
(for scale)

SPTpol
150 GHz
50 deg²



The moon
(for scale)

6x deeper

6x finer angular
resolution

High resolution: small angular scales

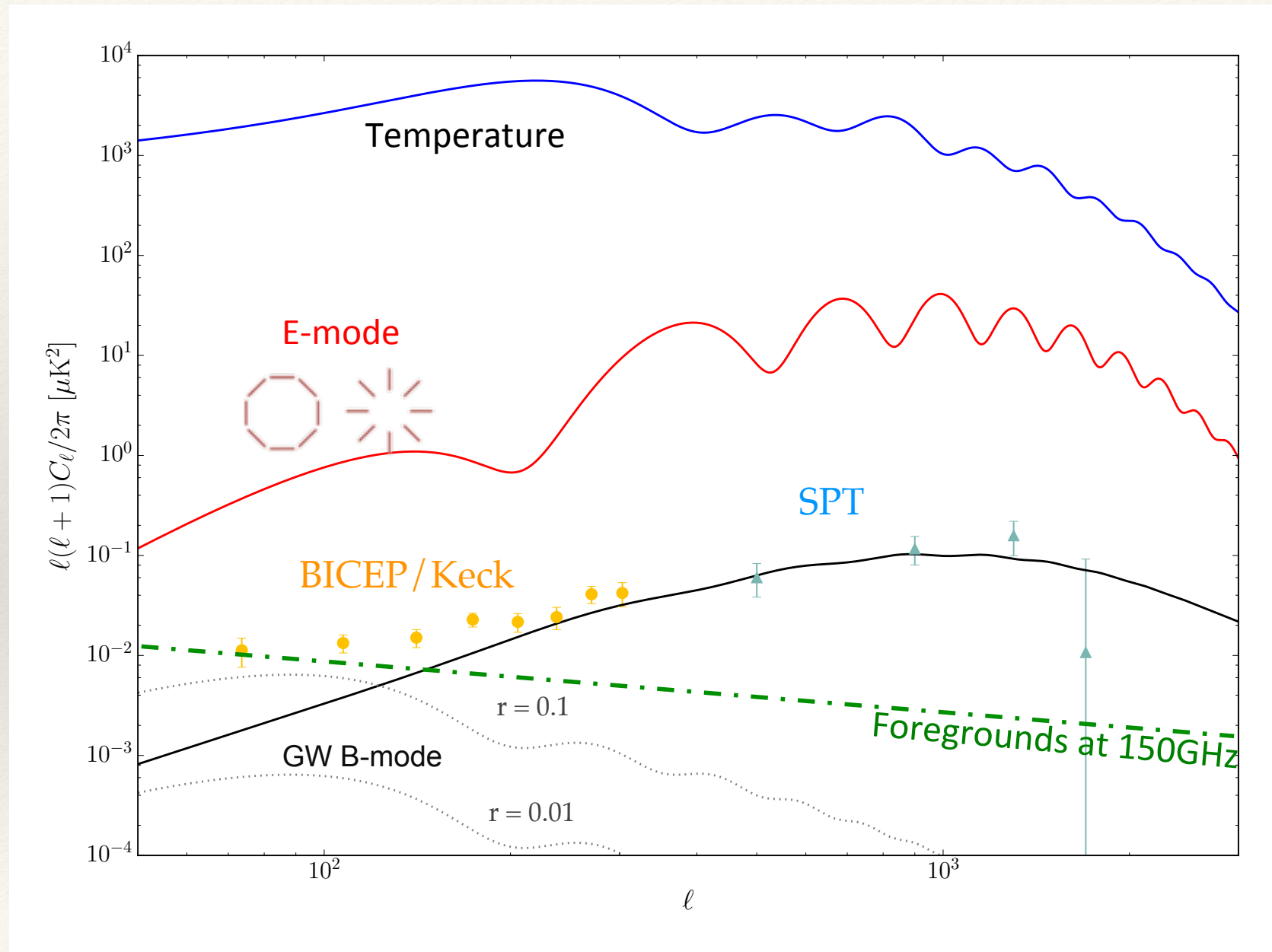

Improving constraints of r through delensing

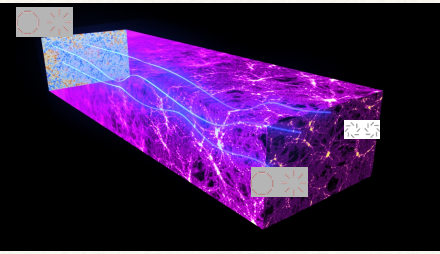

Delensing: the idea

1. Use ϕ tracer and lensed E map to get estimate of lensing B modes

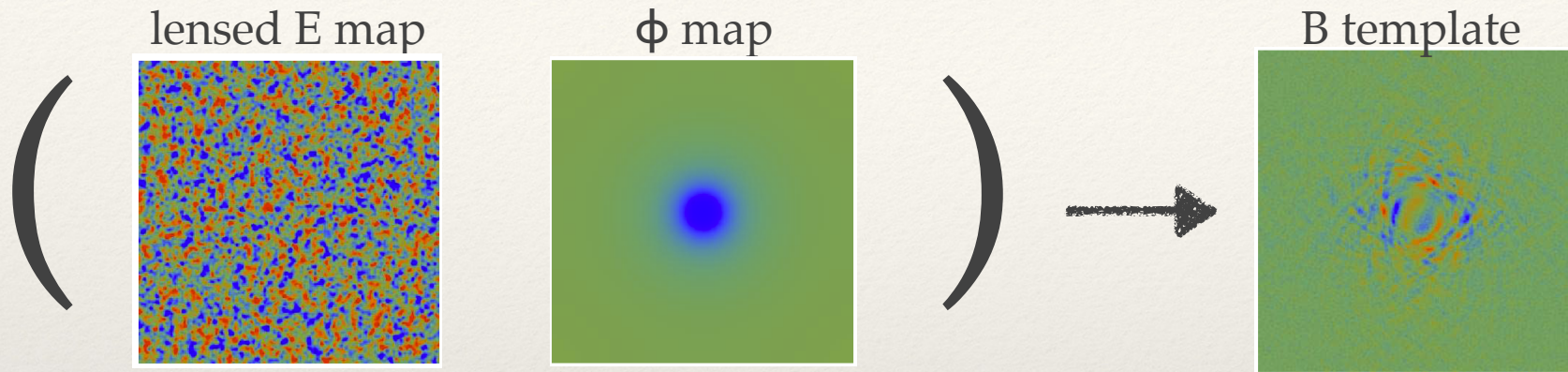
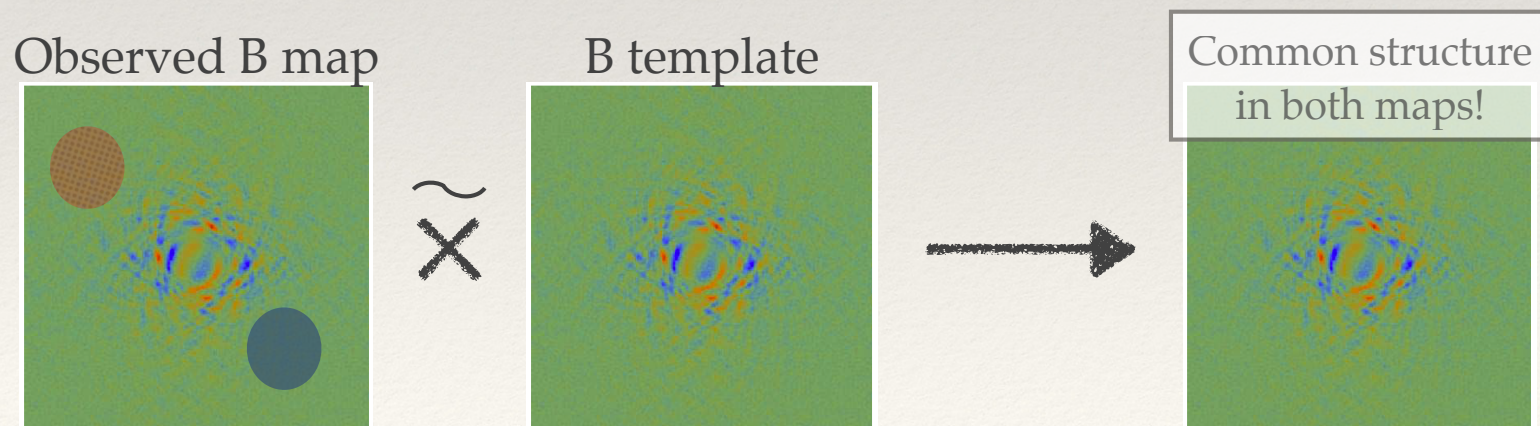

Image credit: Hu & Okamoto (2002)

2. Cross-correlate the lensing B template with observed B mode map to quantify how much lensing B modes are in the observed map



CIB as a ϕ tracer

- ❖ Can reconstruct ϕ from CMB, but S/N rather low currently (Later part of this talk!)
- ❖ Cosmic infrared background (CIB) from dusty star-forming galaxies with redshift distribution peaked between $z \sim 1$ and 2.
- ❖ CMB lensing potential's redshift kernel peaks between $1 < z < 3$
- ❖ Cross-correlation can be as high as $\sim 80\%$

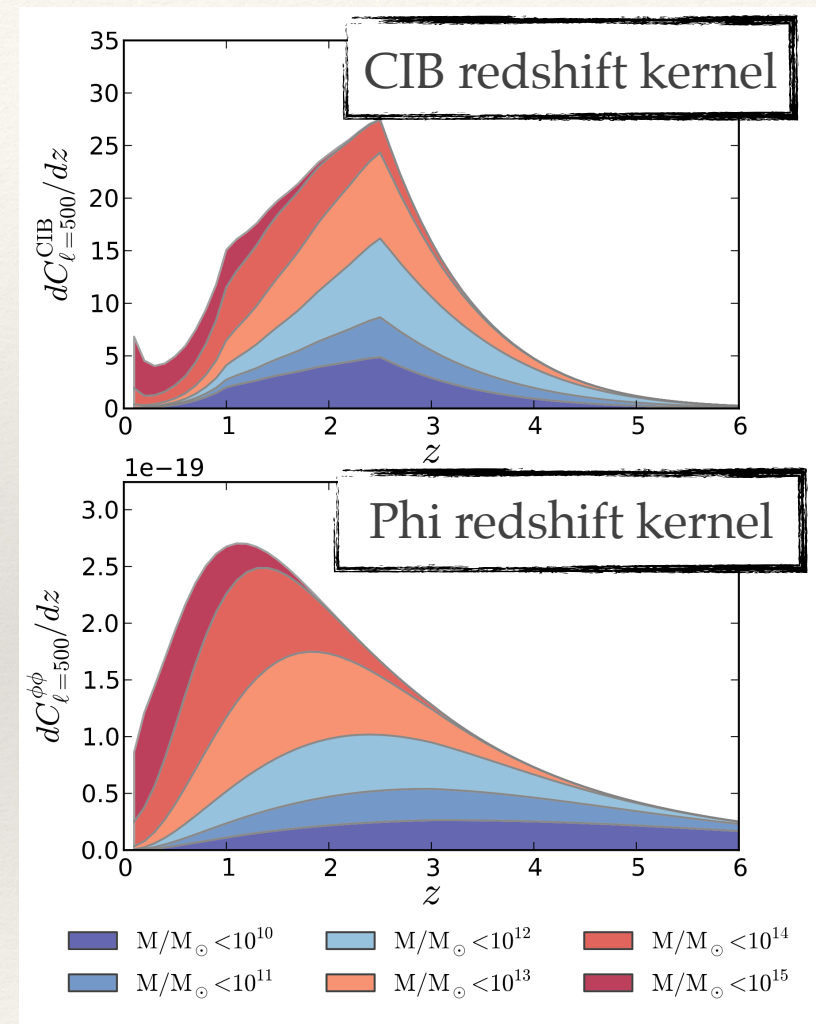

Planck 2013 XVIII

One of the first demonstrations of B-mode delensing



Kyle Story



Alessandro Manzotti

SPTpol
Observed B map

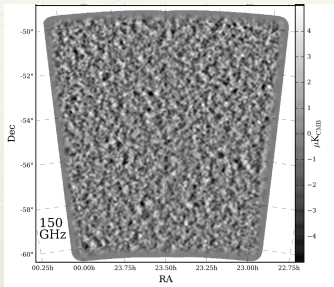

B template

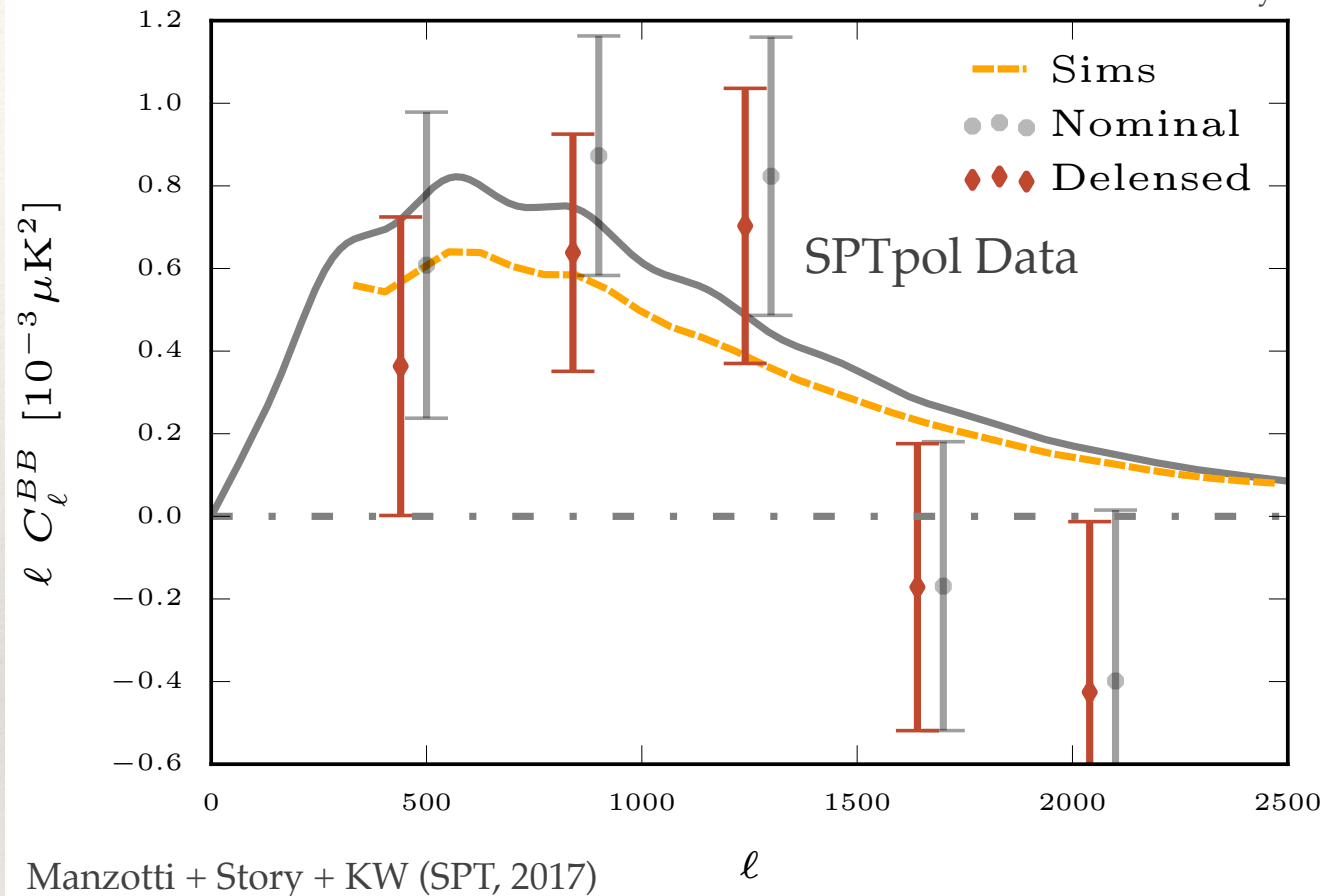
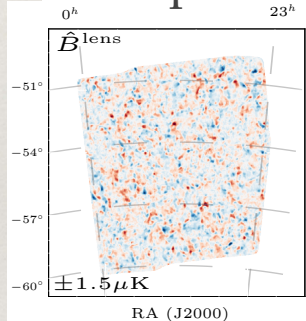

Next: demonstrate improvement on r uncertainty

Inputs to BICEP/Keck lensing template

- ❖ ϕ tracer: Planck's CIB map
- ❖ Q/U maps: combination of BICEP/Keck, SPTpol, and Planck maps

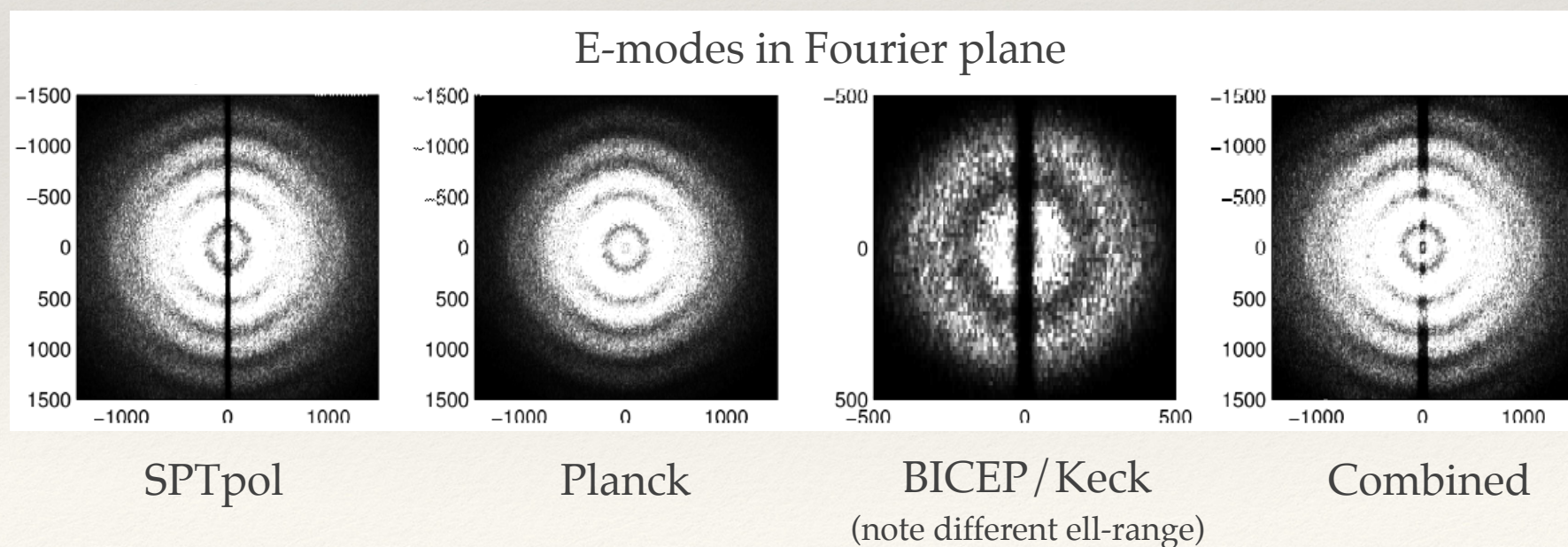
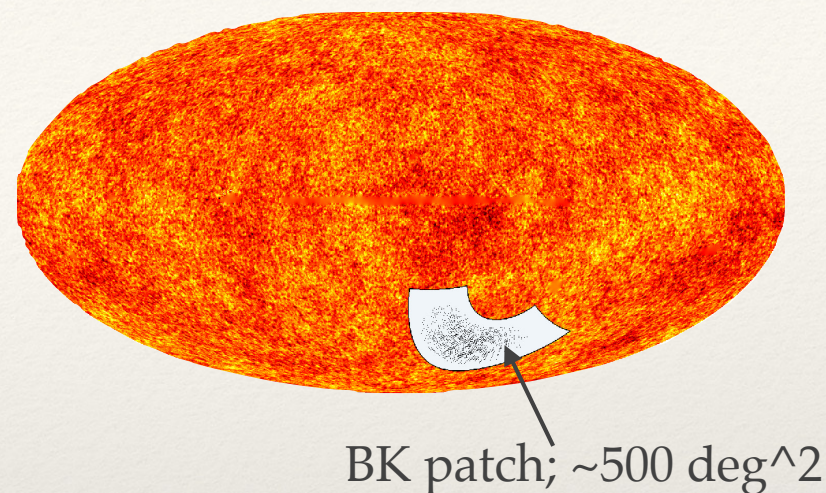

Connecting delensing to $\sigma(r)$

BICEP/Keck likelihood analysis framework:

how is delensing incorporated

BK multicomponent analysis (no delensing)

- Input maps to multicomponent analysis that extracts constraints on r

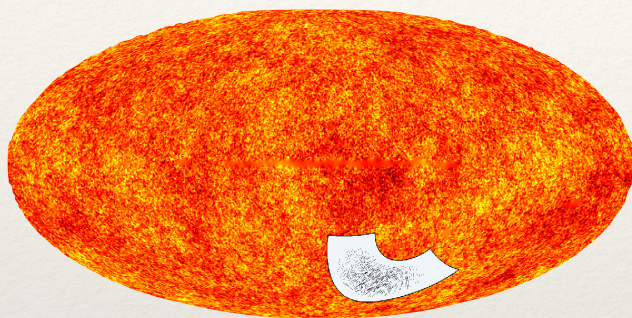

Maps from BICEP/Keck (95/150/220GHz)

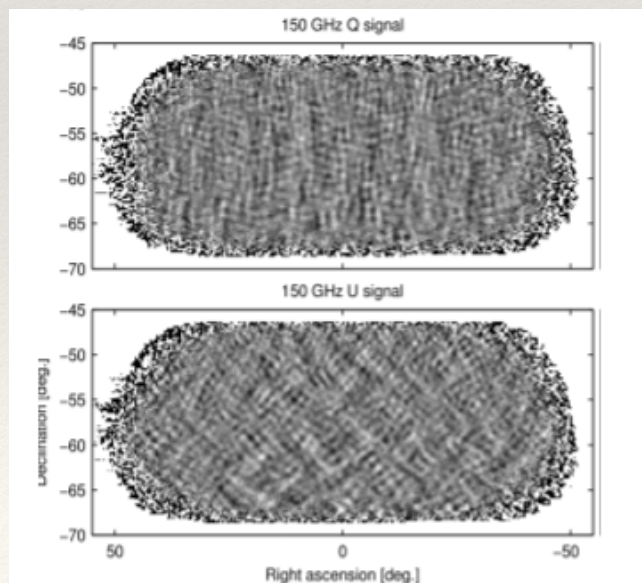

Maps from Planck

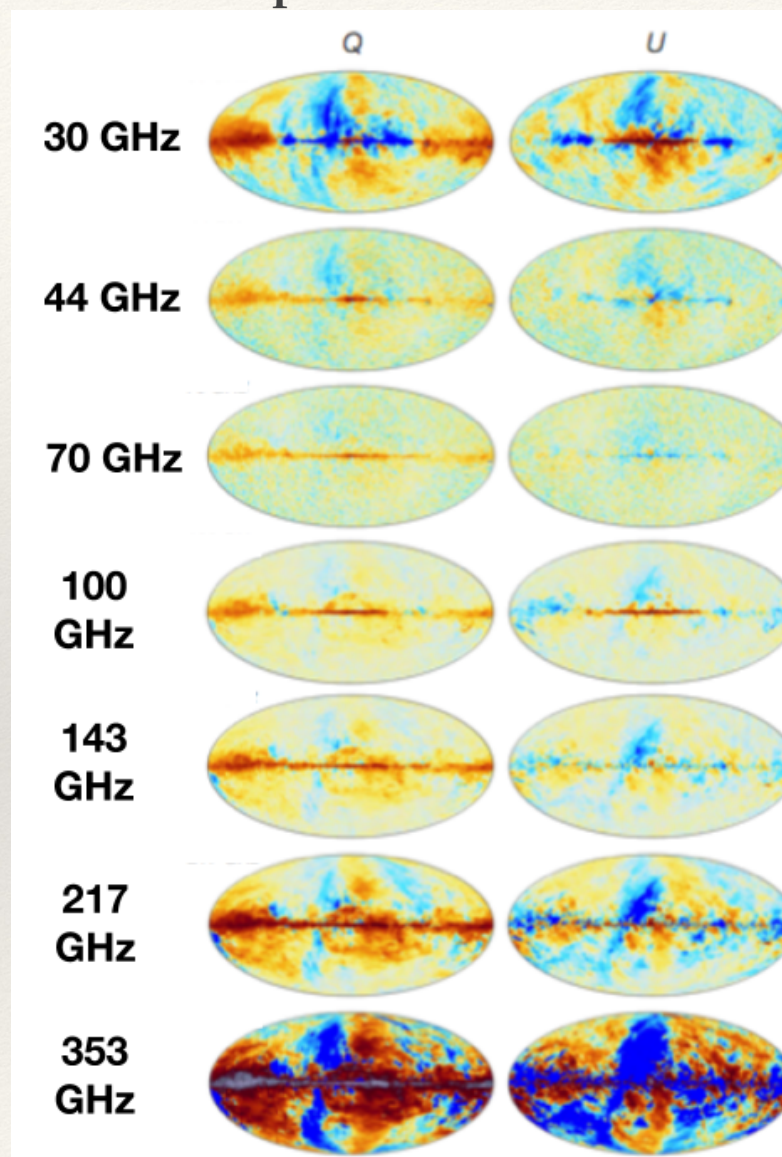

+ WMAP

BK multicomponent analysis (no delensing)

- Take the auto- and cross-spectra of the BICEP/Keck and WMAP/Planck maps
- To calculate the likelihood, compare the data bandpowers against the model expectation values of lensing BB, r , and 7 parameter foreground model:

$A_{\text{dust}}, \alpha_{\text{dust}}, \beta_{\text{dust}}, A_{\text{sync}}, \alpha_{\text{sync}}, \beta_{\text{sync}}$
dust/sync correlation

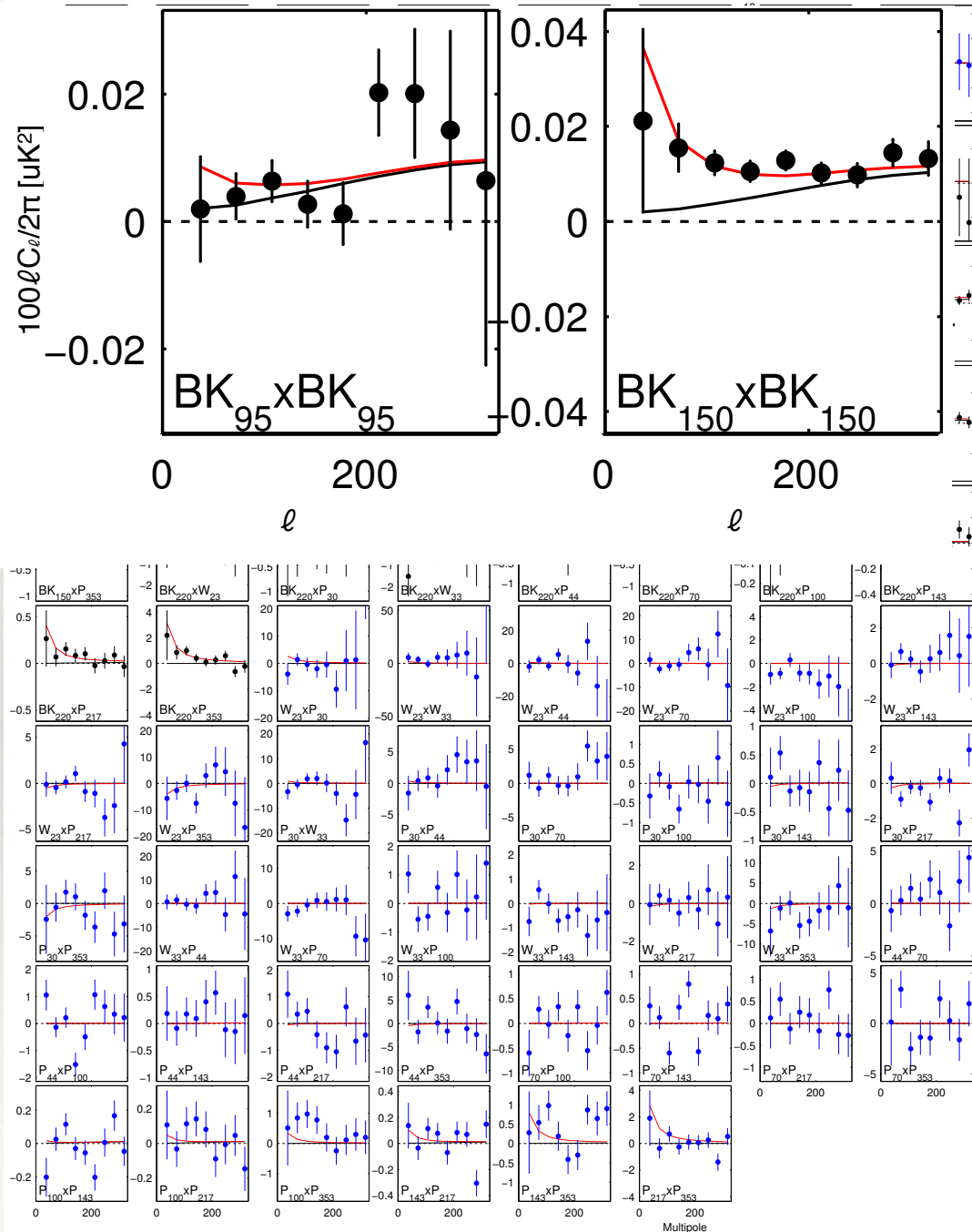

BK15 constraints

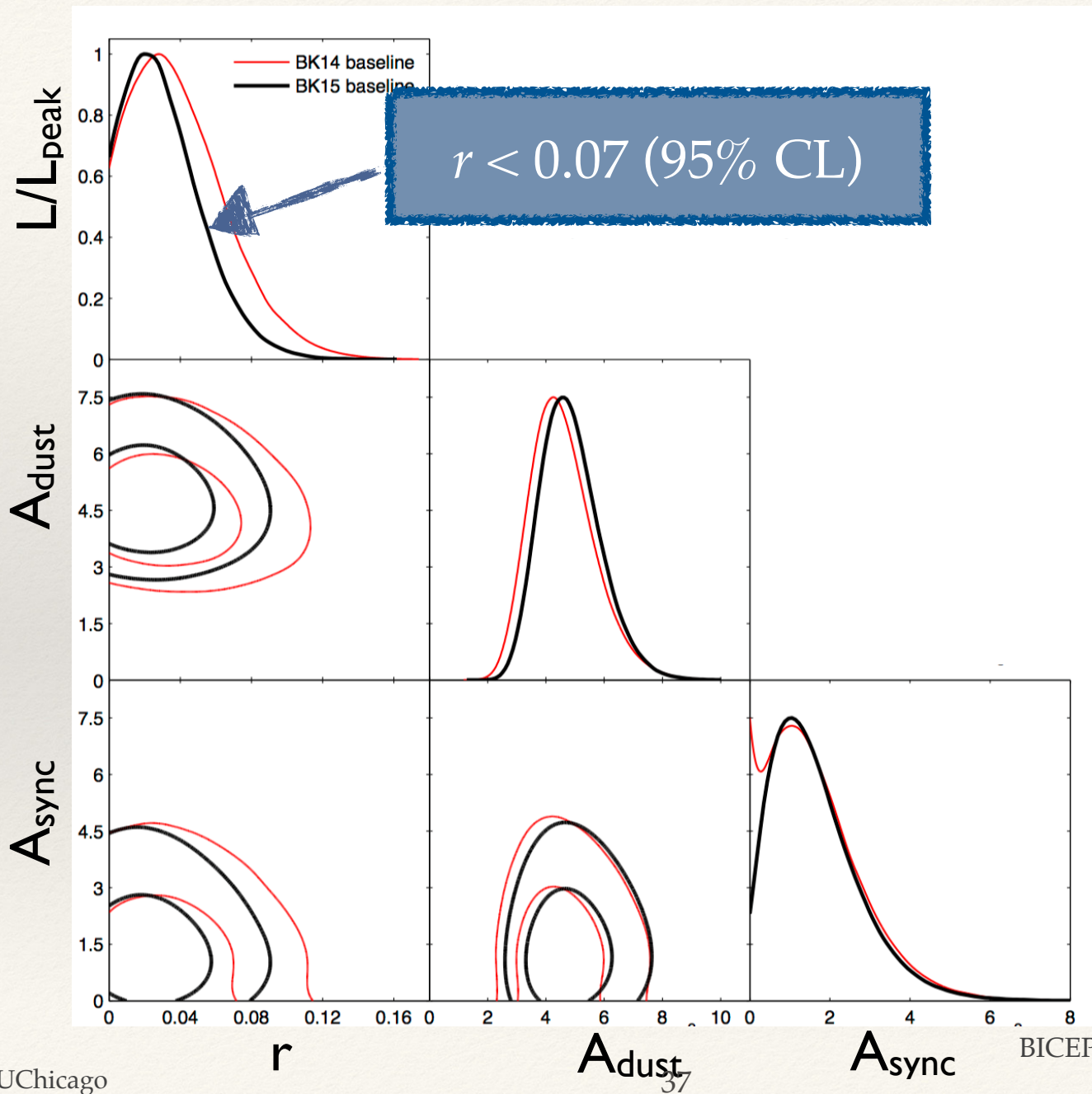

BICEP Collaboration (incl. KW), 2018

BK multicomponent analysis (+ delensing)

- Input maps to multicomponent analysis that extracts constraints on r

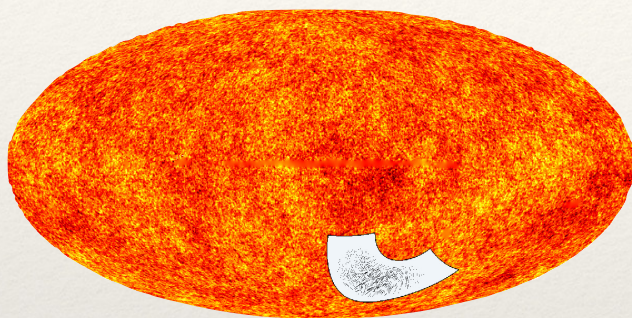

+ lensing template

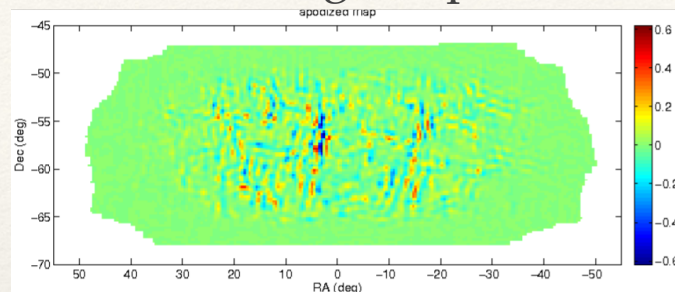

Maps from BICEP/Keck (95/150GHz)

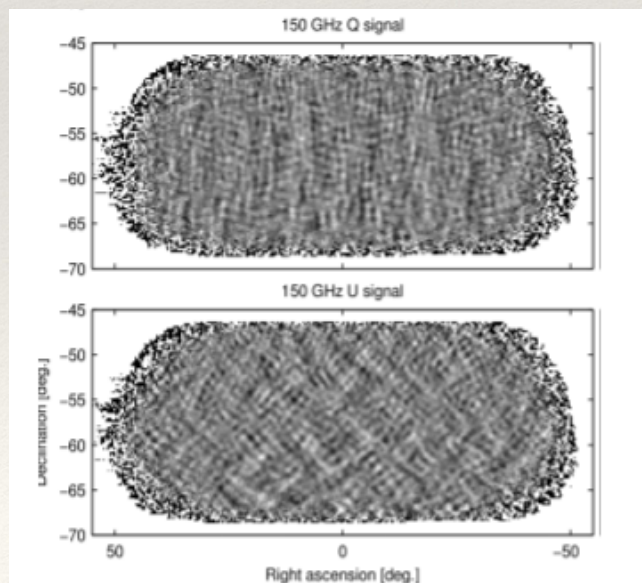

Maps from Planck

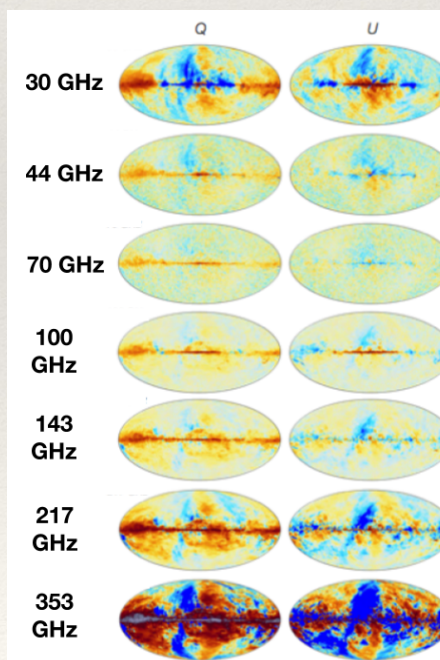

Lensing template as input in multicomponent analysis

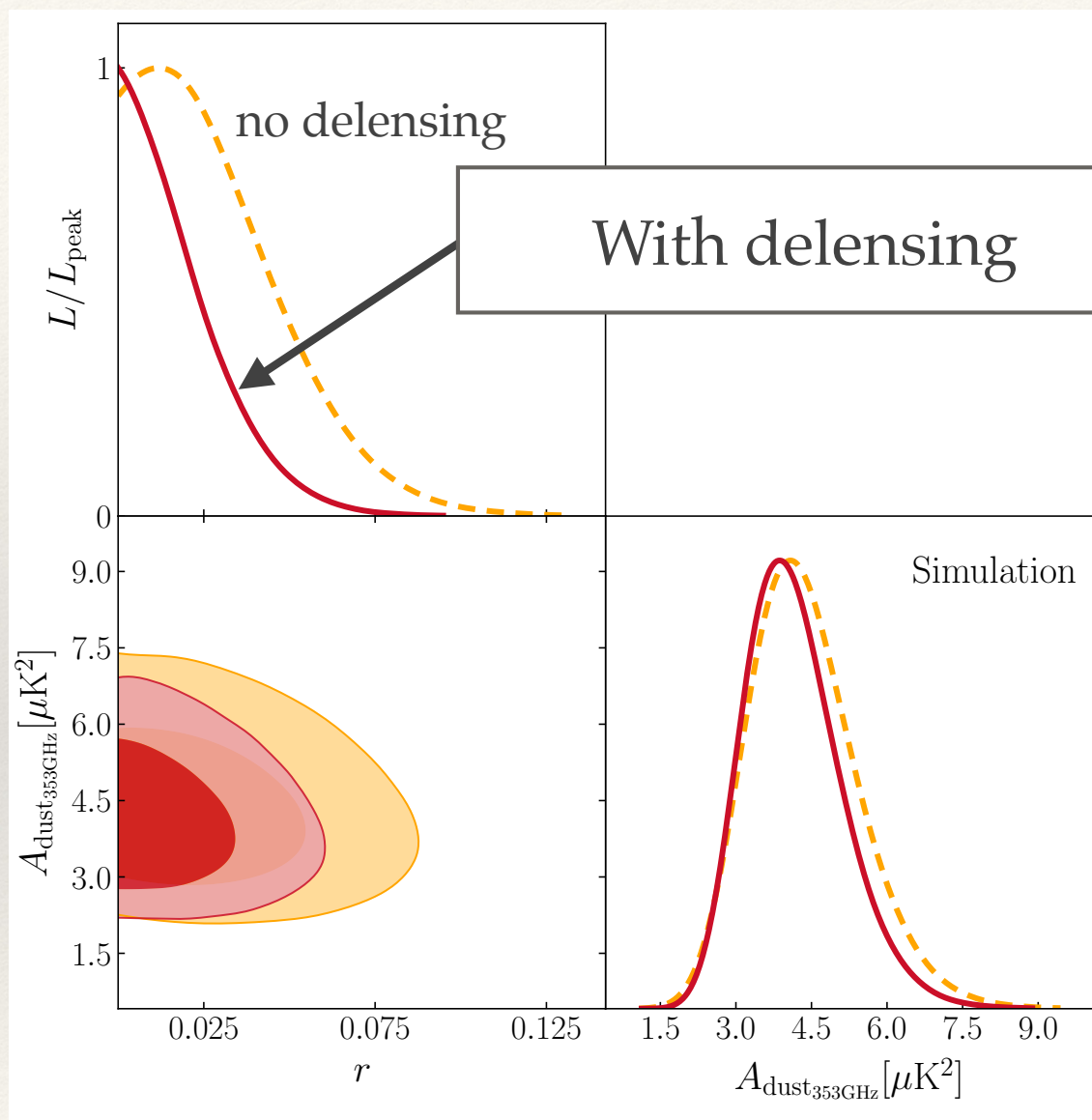

KW+ (BICEP, SPT), in prep.

How much do we improve $\sigma(r)$?

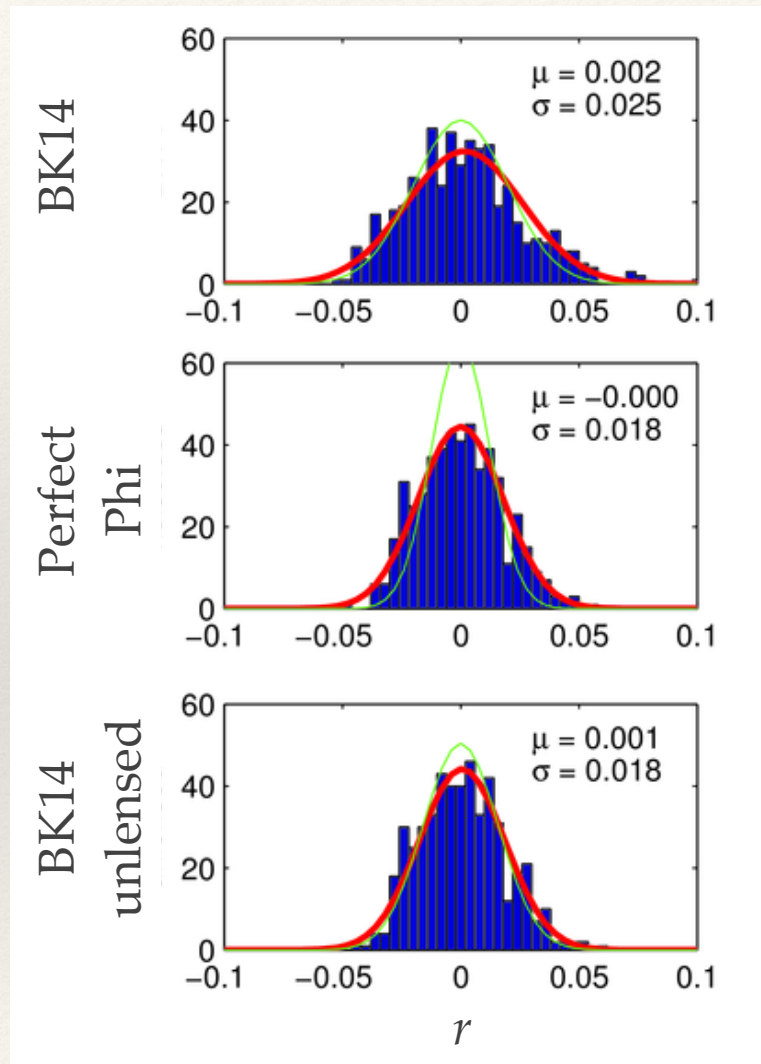

- ❖ With perfect ϕ map (no decorrelation, no noise), adding a lensing template to the BK14 data set improves $\sigma(r)$ from 0.025 to 0.018
- ❖ Using CIB phi tracer to form the lensing template, $\sigma(r)$ improves by $\sim 10\%$ from BK14

First demonstration of $\sigma(r)$ reduction through delensing!

Current limitation to delensing

- ❖ B mode variance is dominated by galactic foregrounds; even with perfect delensing we do not improve $\sigma(r)$ very significantly.
- ❖ Need better ϕ tracer: CIB map we use has cross-correlation with underlying ϕ at 60-80%. CMB-derived ϕ from next-generation CMB experiments will do better!

Key takeaways:

- 1) Incorporated delensing into a likelihood analysis for r ;
- 2) Delensing reduces $\sigma(r)$ by $\sim 10\%$ for the BK14 dataset.

Alternative ϕ tracer: CMB lensing reconstruction

CMB photons are on average deflected by ~ 2 arcminutes coherent on \sim degree scales



Good lensing reconstruction requires high resolution CMB maps.

Lensing correlates CMB modes across angular scales

These correlations are proportional to $\phi(L)$; can use the correlations to measure ϕ !

Background image credit: ESA

SPTpol 500 deg²

SPTpol lensing map



Monica
Mocanu

$$\bar{\phi}_{\mathbf{L}}^{XY} = \frac{1}{R_{\mathbf{L}}^{XY}} \int d^2\ell W_{\ell, \ell-\mathbf{L}}^{XY} \bar{X}_{\ell} \bar{Y}_{\ell-\mathbf{L}}^*$$

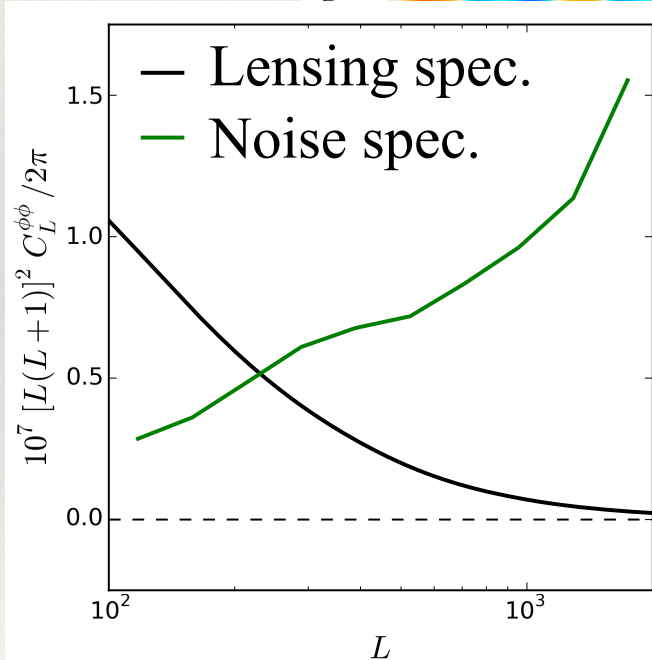
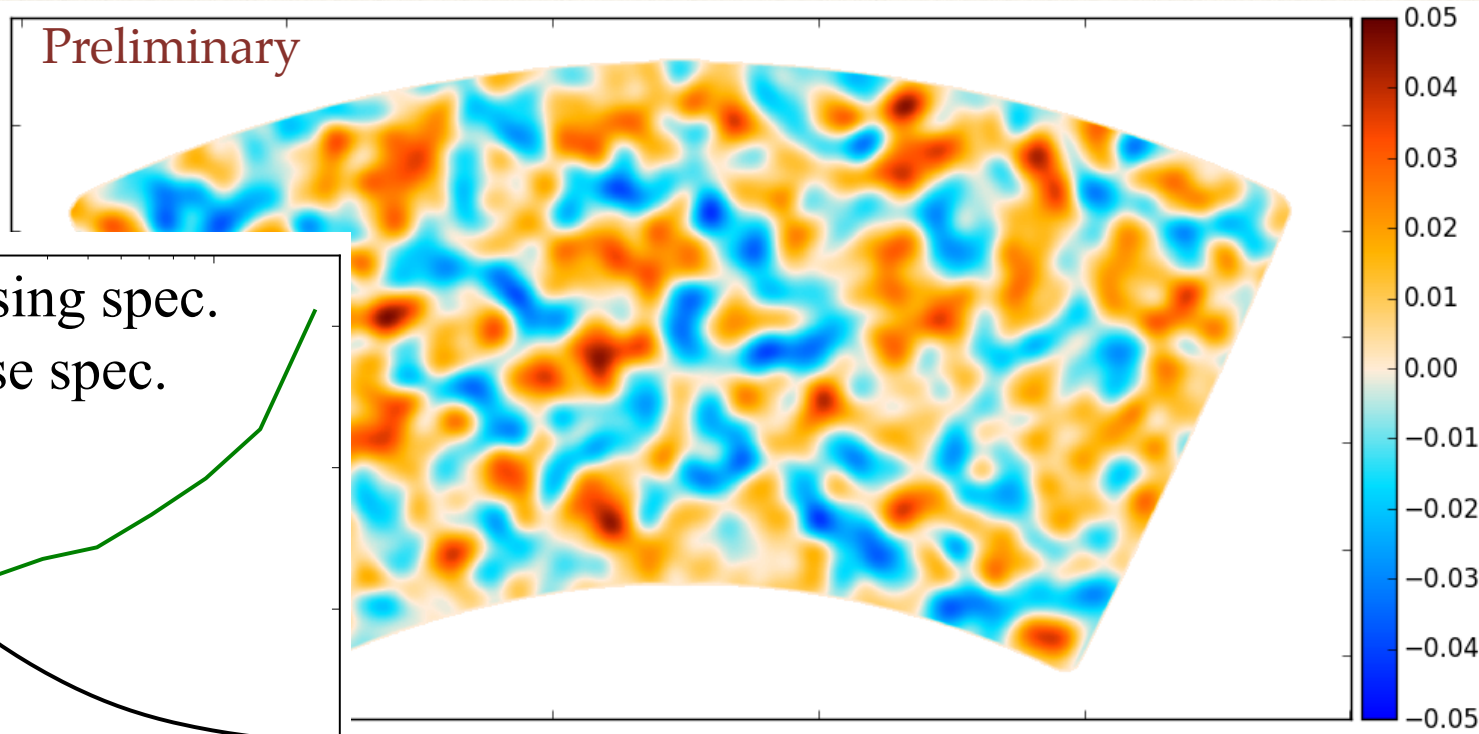
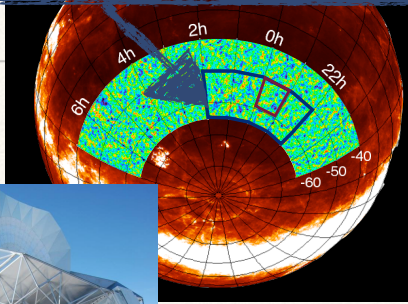

Mocanu+KW (SPT), in prep.

Highest S/N per mode reconstruction to-date!

Gravitational lensing as a signal!

$$\text{Lensed field } (\hat{n}) = \text{unlensed field } (\hat{n} + \nabla\phi)$$

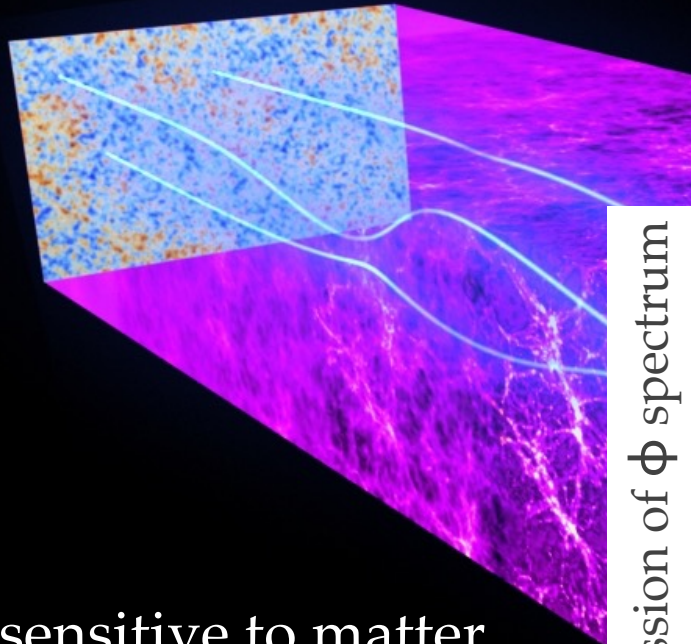

Suppression of ϕ spectrum
with non-zero M_ν

ϕ : sensitive to matter density and structure growth; can be used to constrain e.g. sum of neutrino masses.

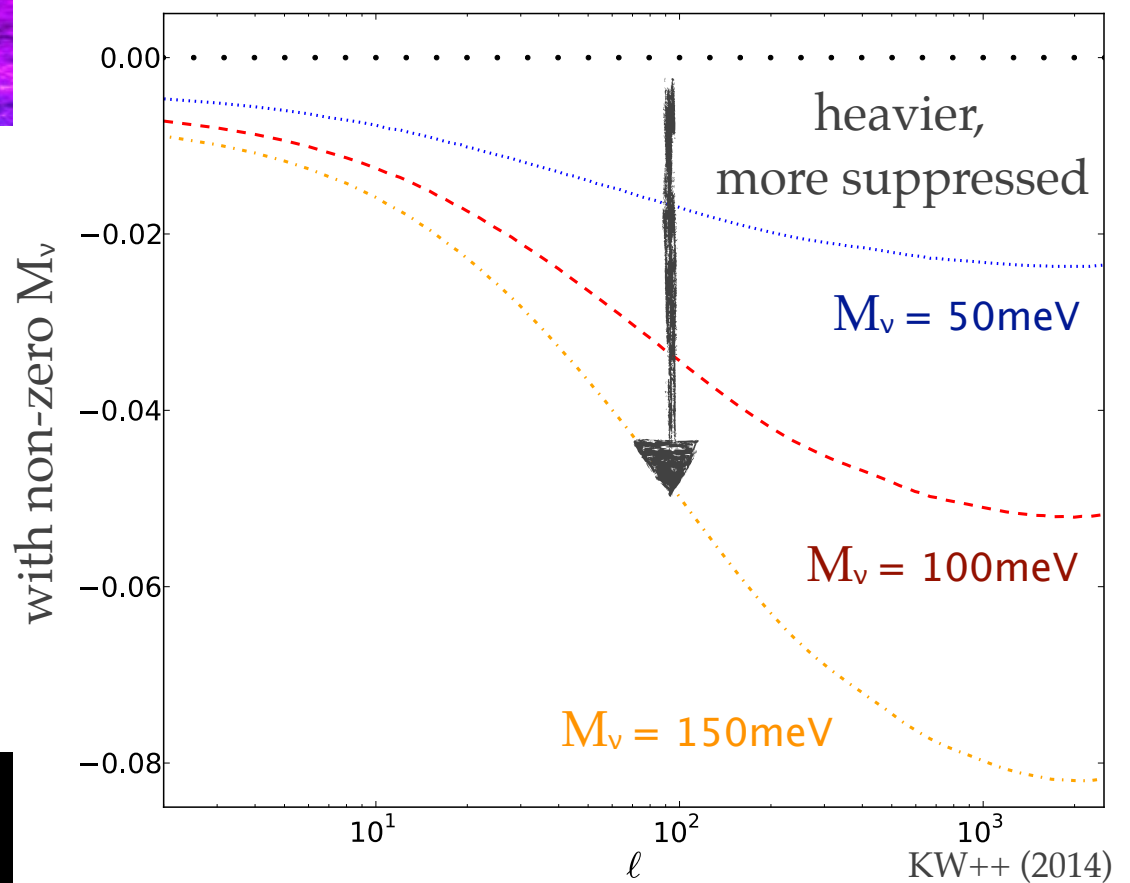

Background image: ESA

Cosmology from the $Cl^{\phi\phi}$ spectrum

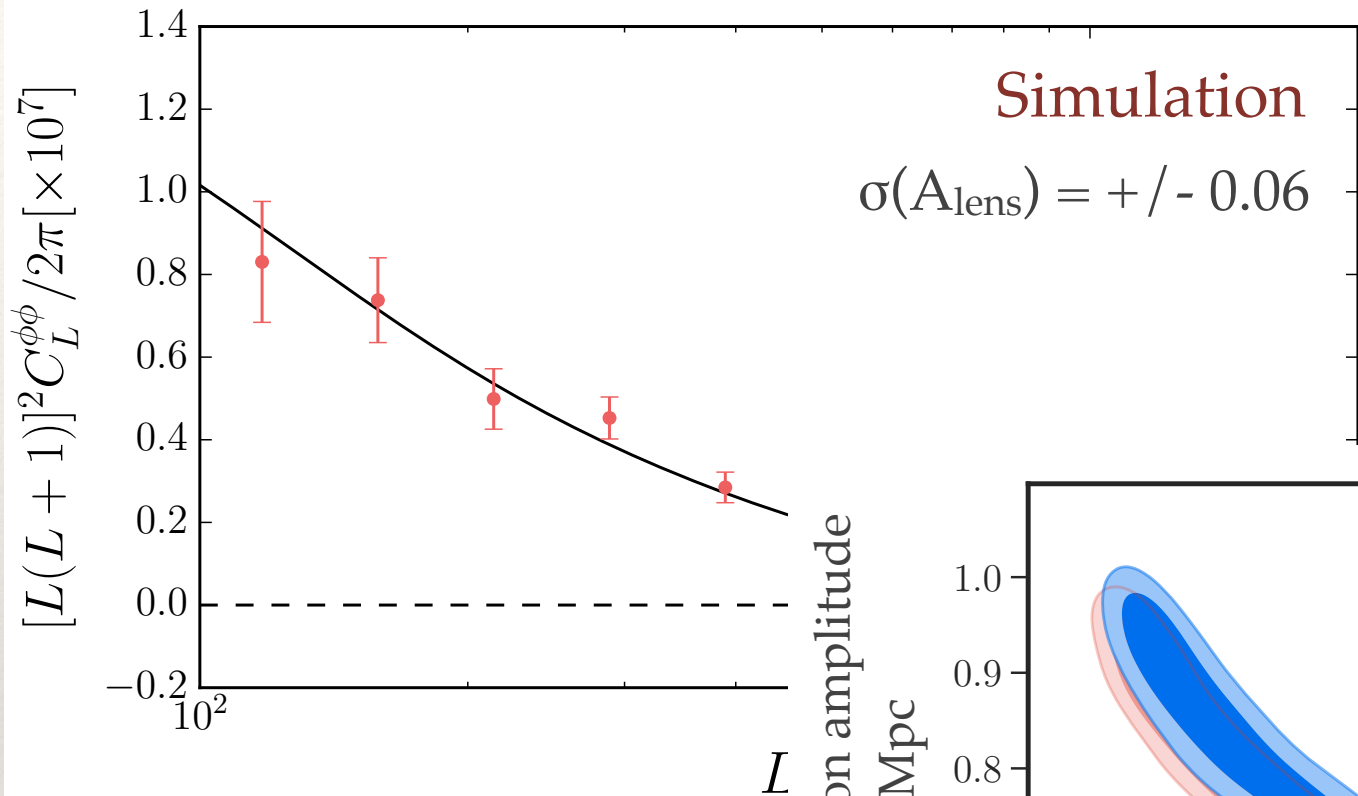

Comparable constraints to
 Planck lensing!

σ_8 : Mass fluctuation amplitude
 within 8 Mpc

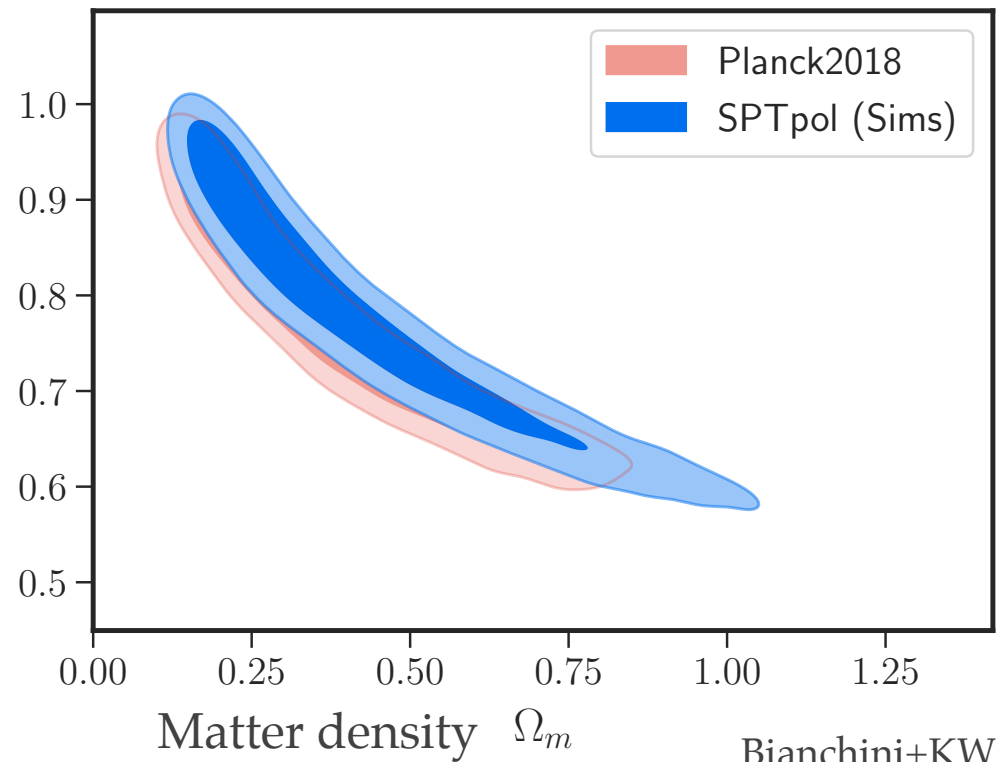

Bianchini+KW

Delensing efficiency

Cross-correlation of tracer
and ϕ -field

$$\rho_\ell = \frac{C_\ell^{\text{tracer}-\phi}}{\sqrt{C_\ell^{\text{tracer-tracer}} C_\ell^{\phi\phi}}}$$

For CMB reconstructed ϕ

$$\rho_\ell = \sqrt{\frac{C_\ell^{\phi\phi}}{C_\ell^{\phi\phi} + N_\ell^{\phi\phi}}}$$

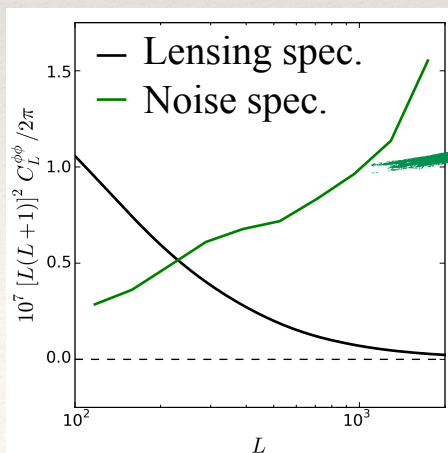
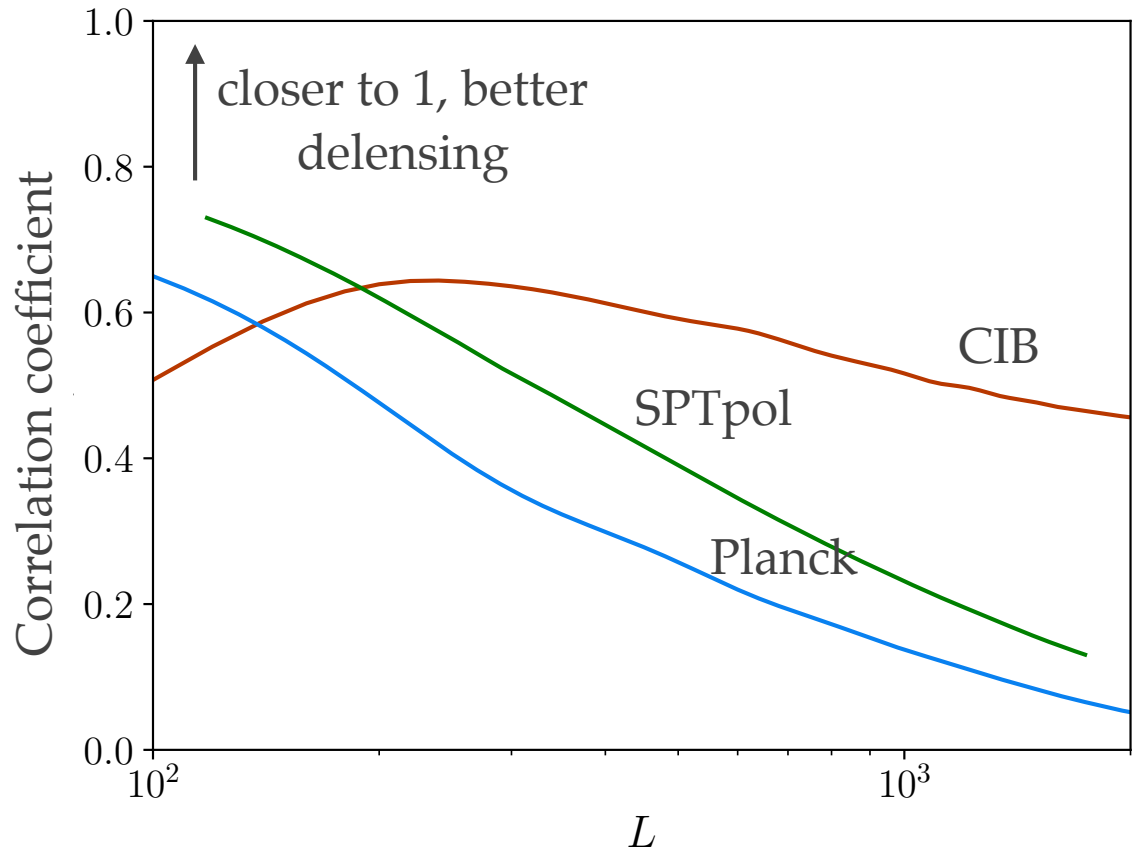

- ❖ In the limit that the E-mode noise is small, the correlation between the ϕ tracer and the underlying ϕ field determines how well the lensing B-modes are estimated \rightarrow delensing efficiency

How to get better ϕ ?

- 1) Make deeper high-res CMB maps
- 2) Extract lensing information more optimally

Neural networks for CMB lensing reconstruction

Why neural network?

Observables:
lensed CMB maps

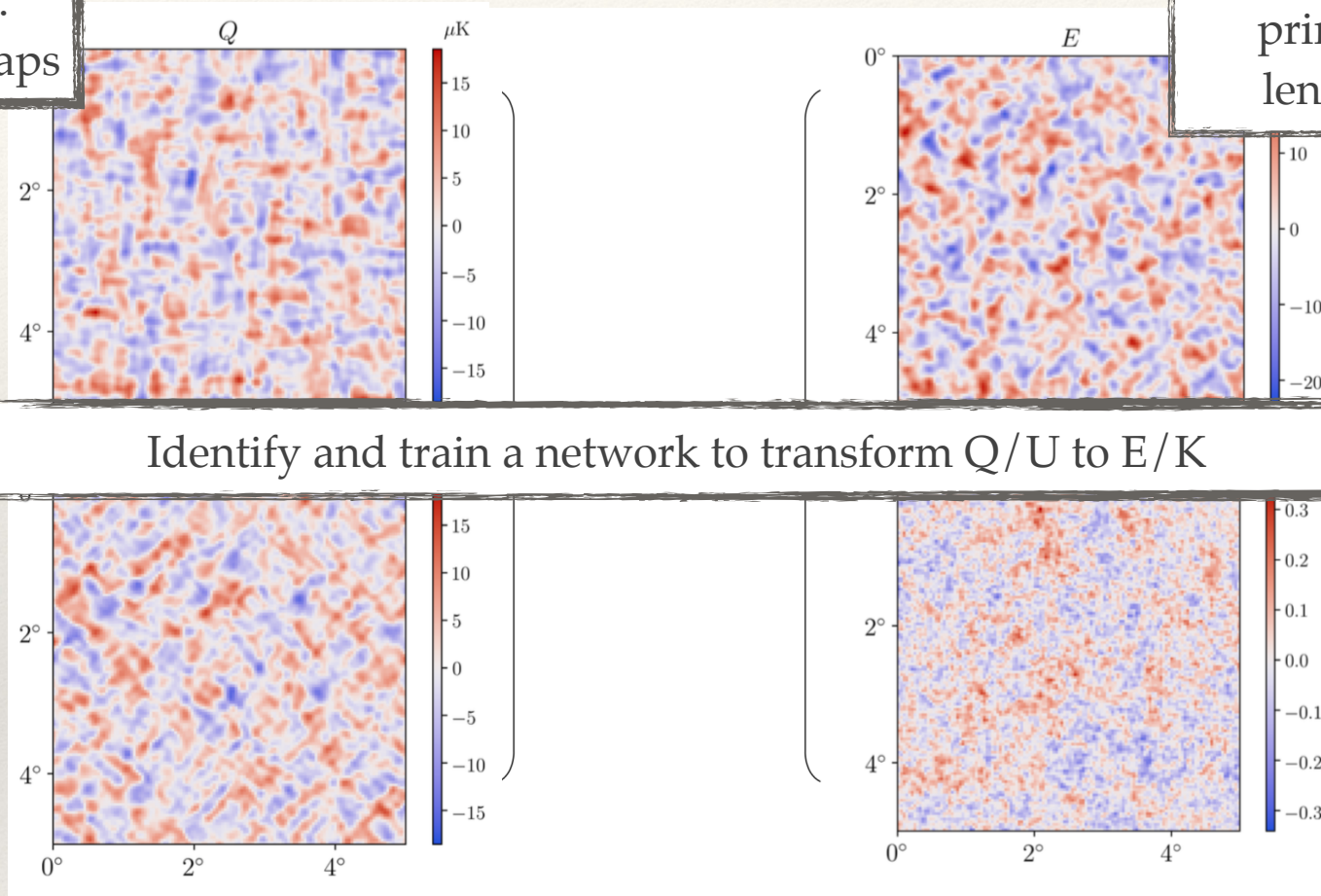

Underlying fields:
primordial CMB,
lensing potential

Identify and train a network to transform Q/U to E/K

- We need a tool to transform one set of images to another \rightarrow neural networks seem to be a good fit to this problem.
- Neural networks are also intrinsically non-linear \rightarrow could potentially be useful for extracting beyond-Gaussian information (e.g. foregrounds, instrumental systematics, non-Gaussian lensing information).
- Maximum likelihood solution

Network architecture

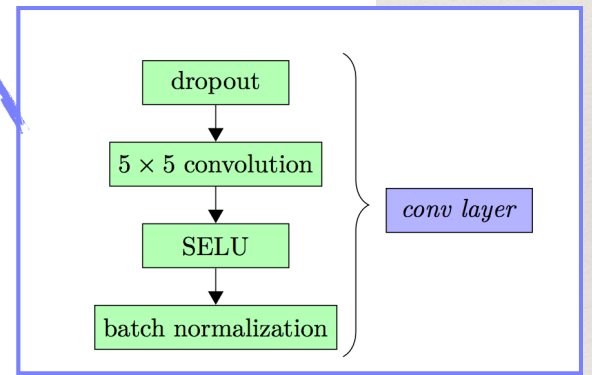
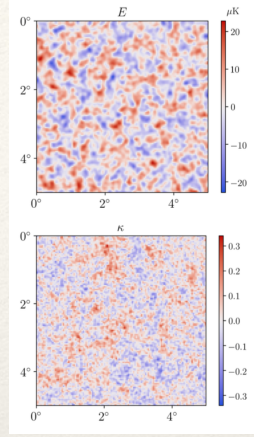
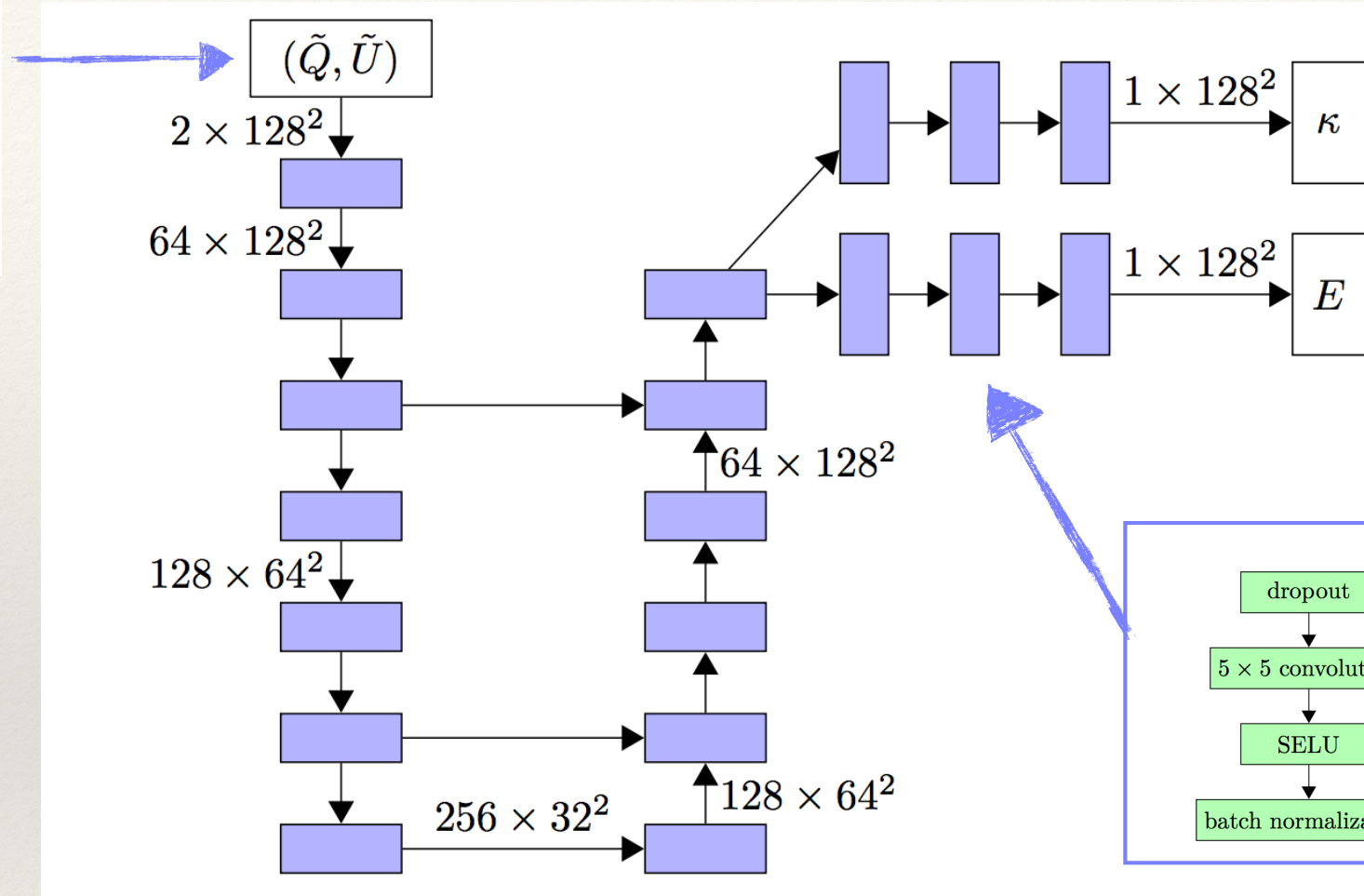
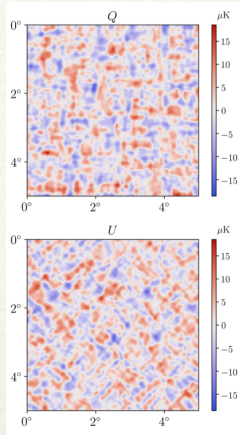

- 11200 sets of Q/U, E/K sim maps; 80:10:10 training:validation:test sets
- The loss function is MSE (mean square error) between the output E/K and the true E/K; the network chooses weights to minimize the MSE.
- Residual UNet: “residual connections” at before each dimension changing step; “skip connections” across the layers with same dimensions

Lensing field recovery

CMB map noise

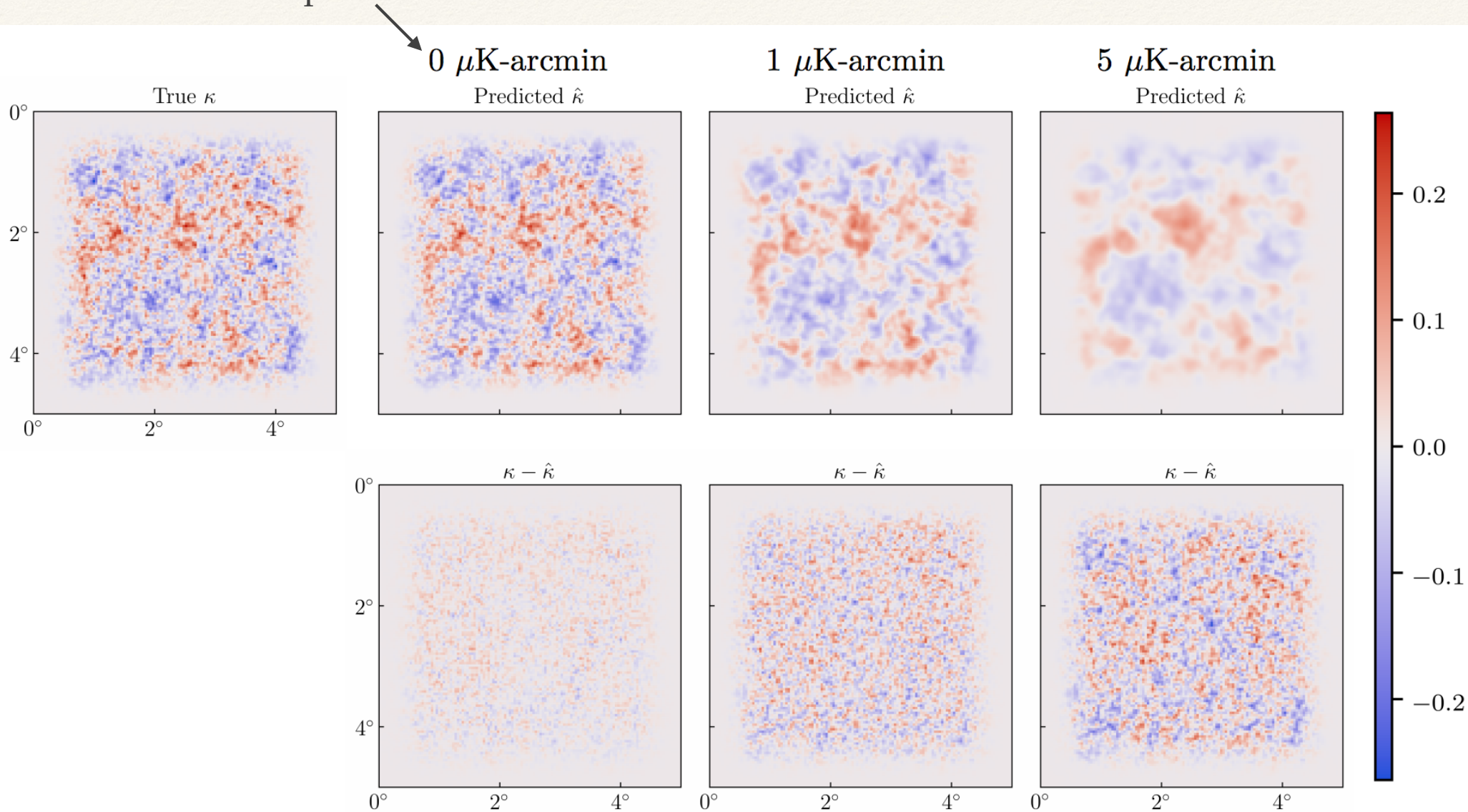

Compare to “physics-ful” methods



Joao Caldeira
Fermilab/KICP

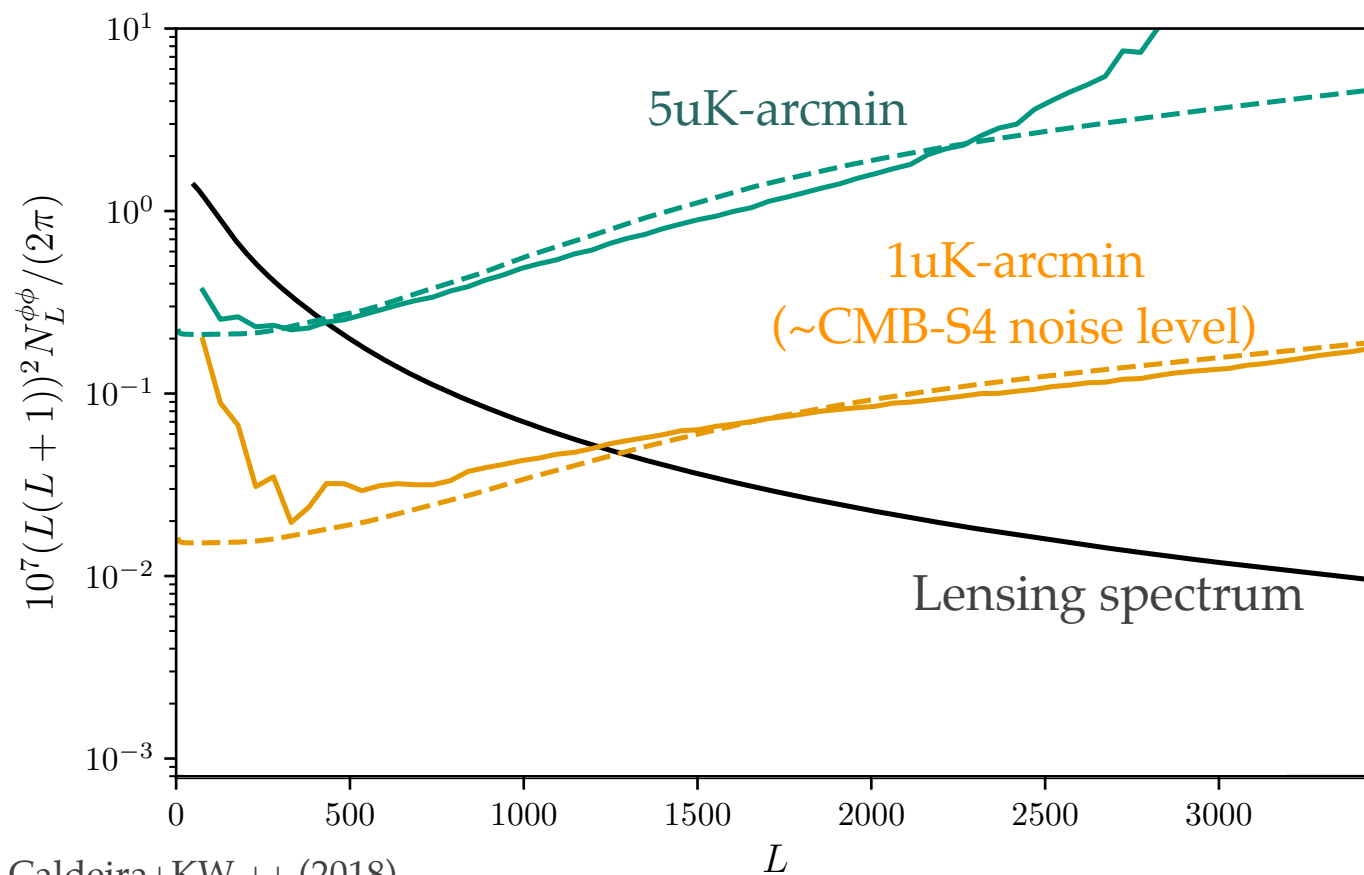

Caldeira+KW ++ (2018)

solid lines: neural net
dashed lines: maximum likelihood approximation

- The NN approach does not completely recover the input. So we model the decorrelation as a noise term and compare that to standard methods' noise.
- Lensing reconstruction noise from the neural nets approaches that of maximum-likelihood methods. It works!

Tests

Is the network really sensitive to lensing??

- Null test
- Sensitive to differences in input Ω_M

How sensitive are the outputs to the initialization randomness?

- Randomness due to initialization

Toy fit for cosmology

- Fit Ω_M

- 1) maps that are not lensed
- 2) maps generated with more/less Ω_M

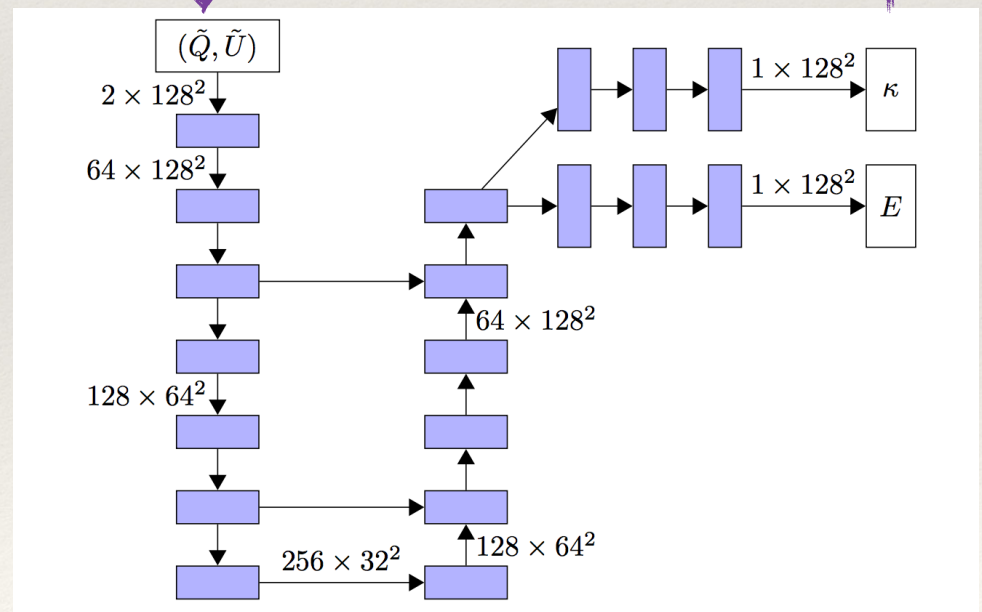
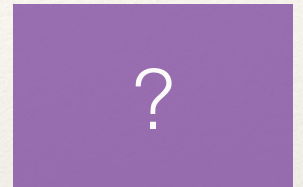

Key takeaways:

- 1) The network κ recovery's S/N is similar to maximum-likelihood methods;
- 2) Network is sensitive to changes in cosmology;
- 3) Lots to explore in understanding how the network extracts information and incorporating more realistic foregrounds and systematics effects;
- 4) Potentially superior for extracting instrumental and astrophysical systematic effects that are hard to model.

The near future of r and delensing

SPT-3G for (de)lensing

BICEP Array for component separation

SPT-3G status

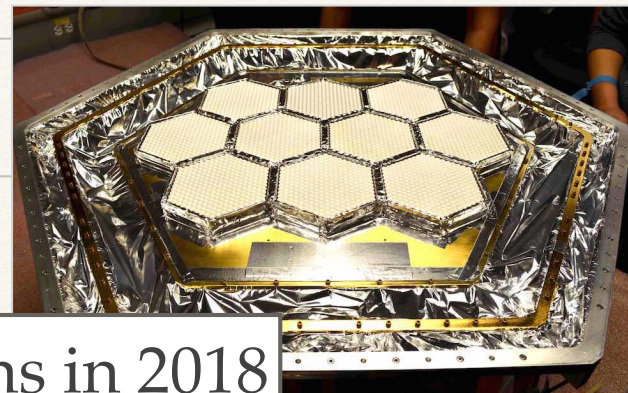
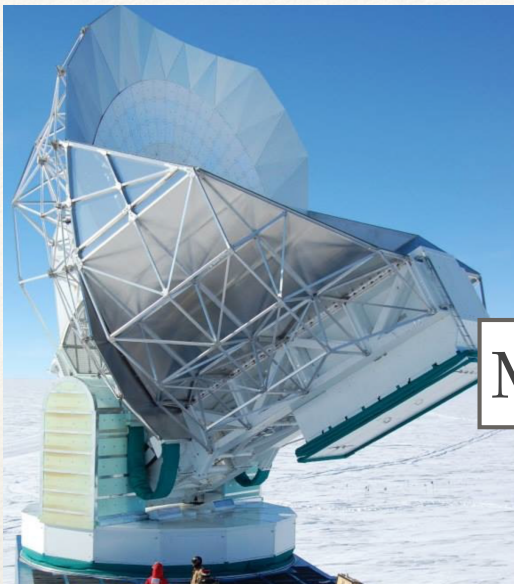

Map from 1 week of observations in 2018

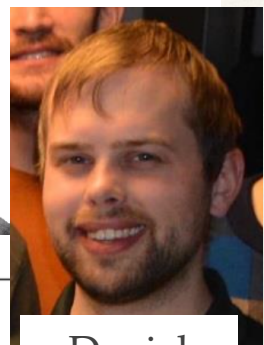
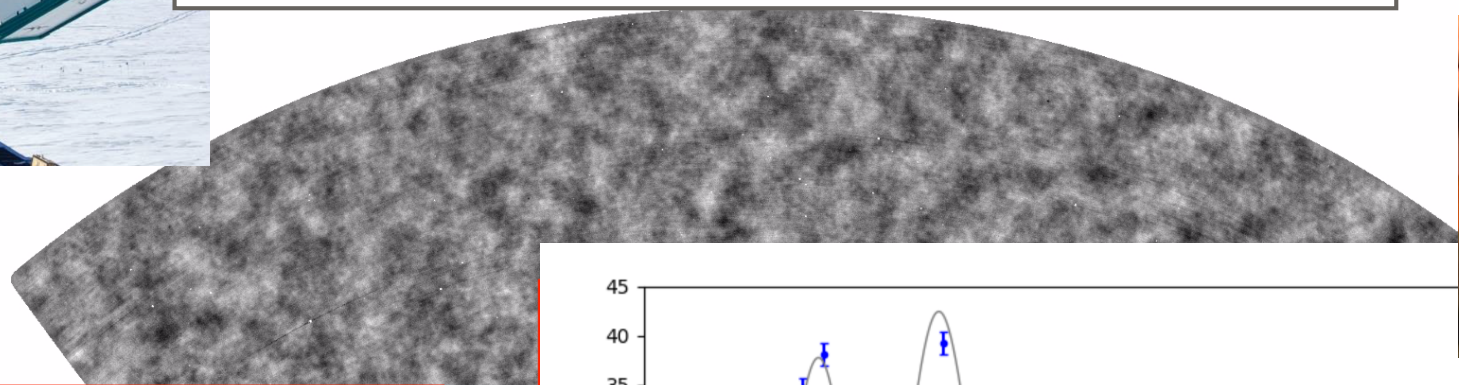

Daniel Dutcher

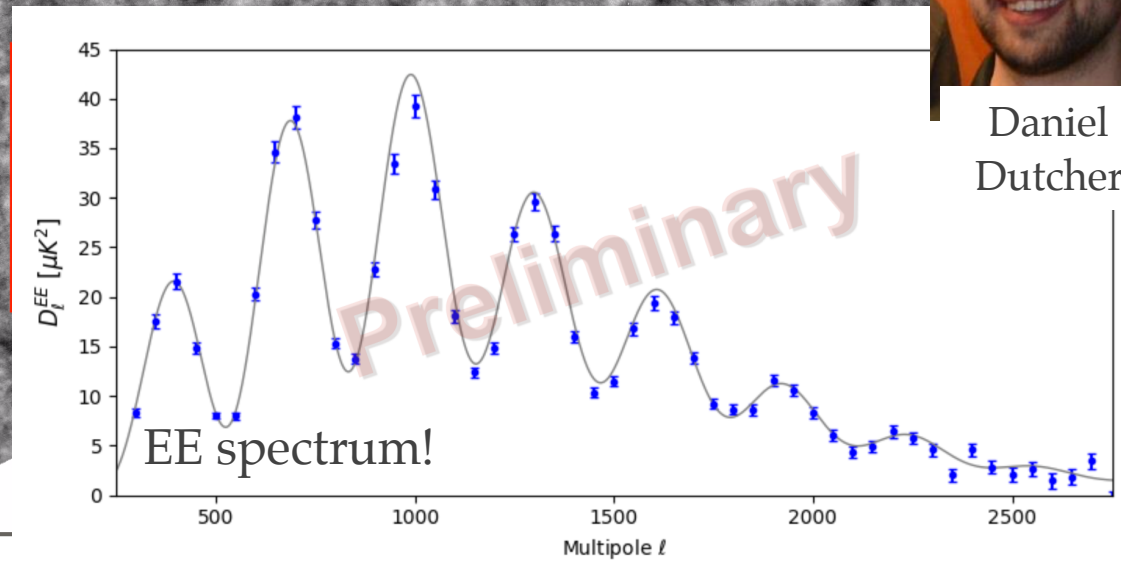
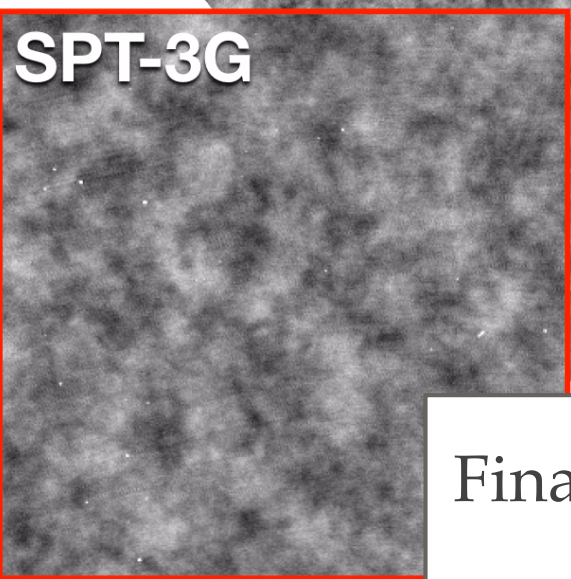

Final depth by 2023 at 150 GHz
> 3x SPTpol



SPT-3G+BICEP Array

1500 deg²

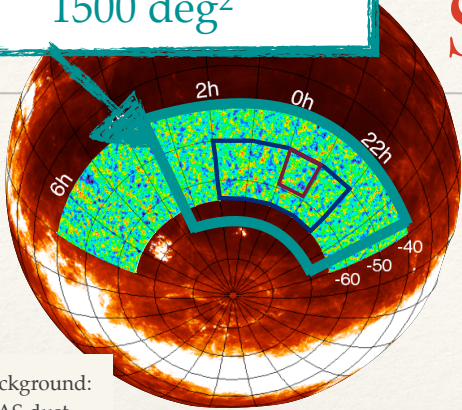

Background:
IRAS dust

SPT-3G delensing efficiency

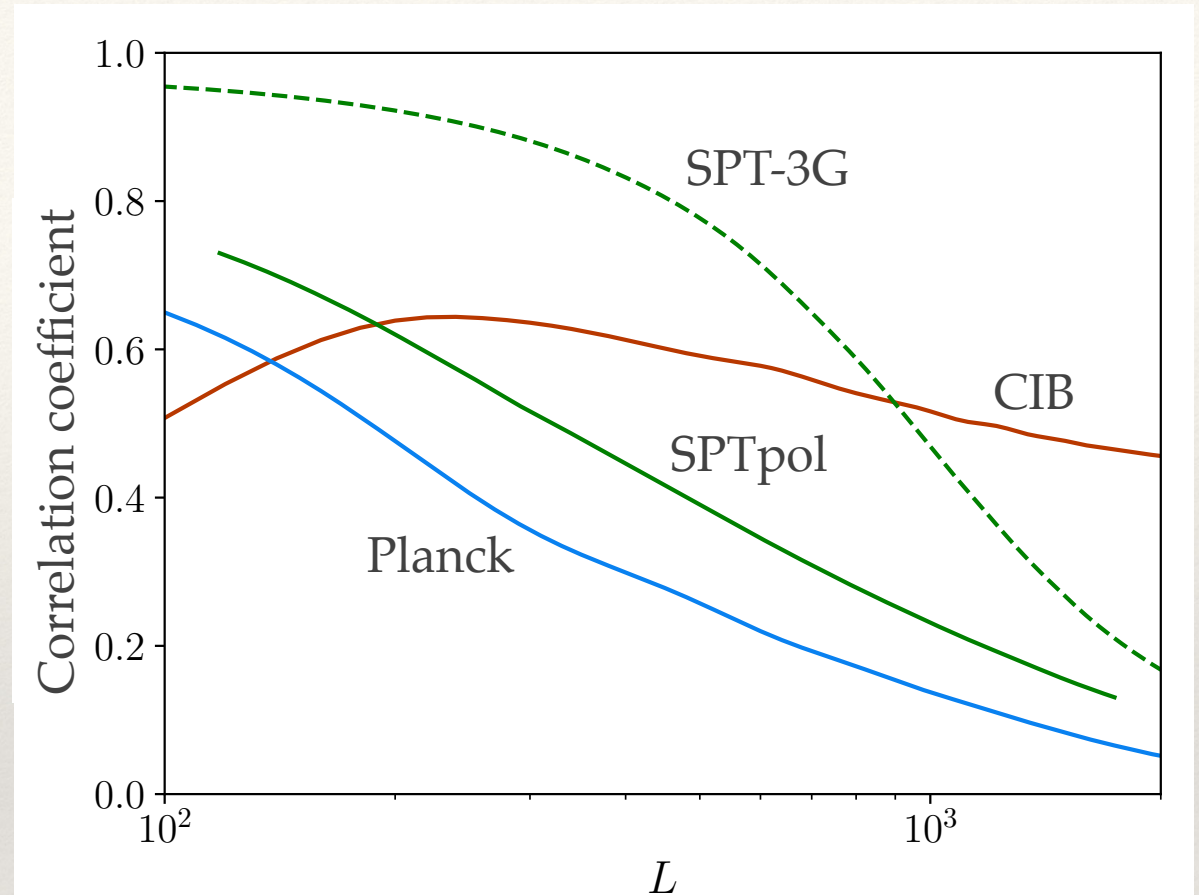
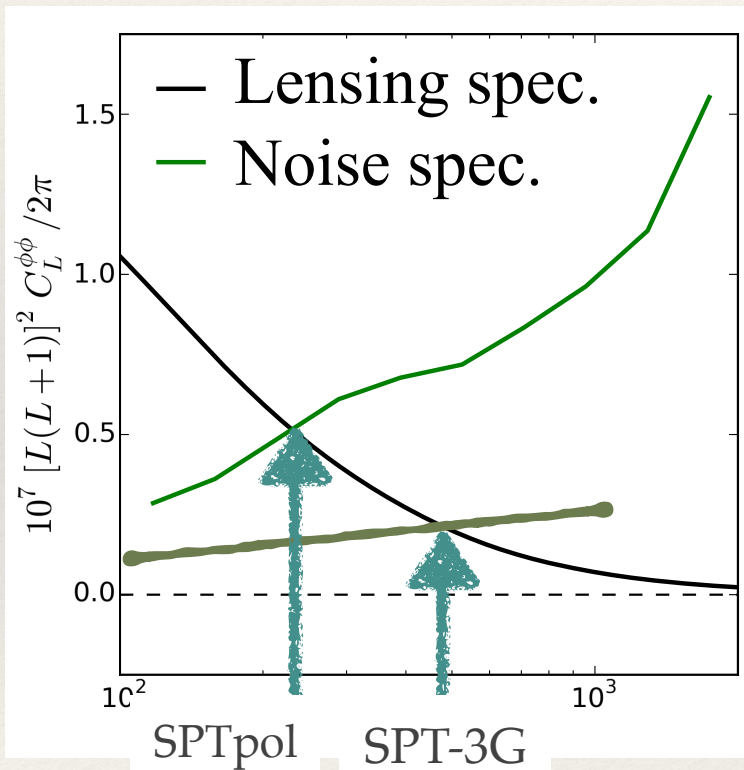

CMB reconstructed ϕ will soon be the best lensing potential tracer for B-mode delensing

Keck 95 GHz

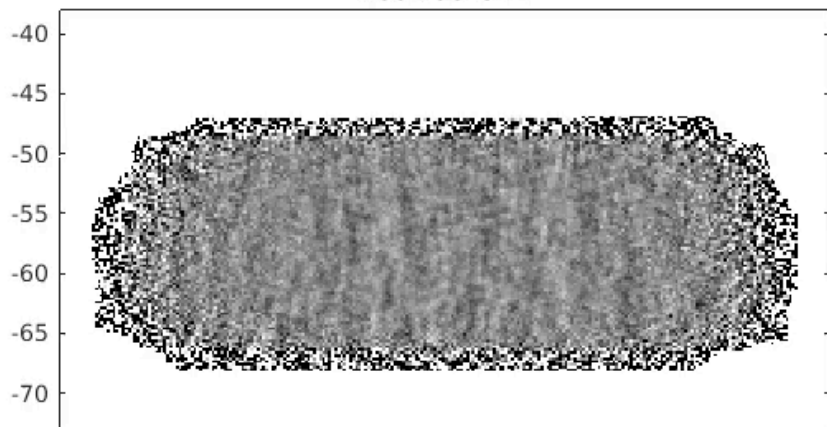

BICEP3 95 GHz

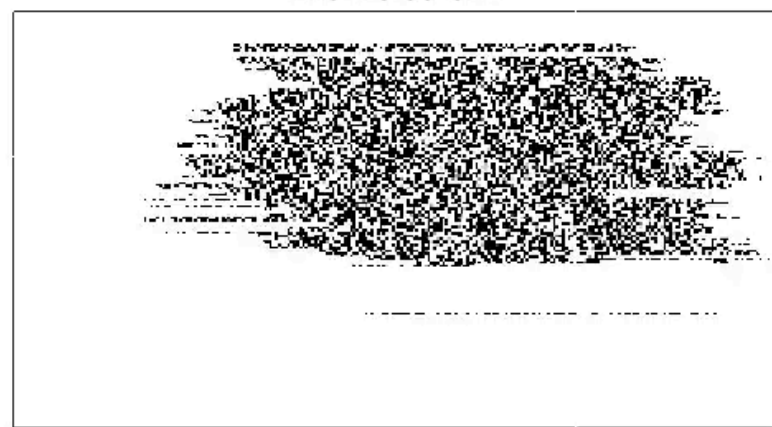

Keck 150 GHz

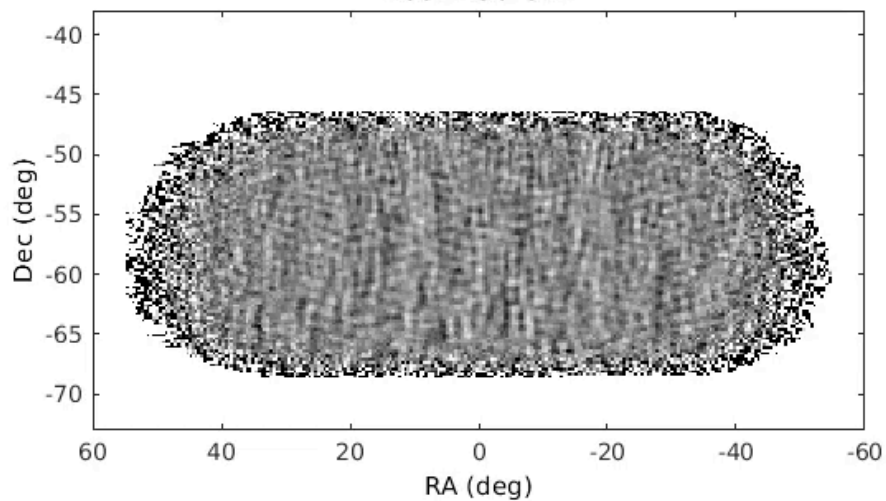

BICEP3 Noise

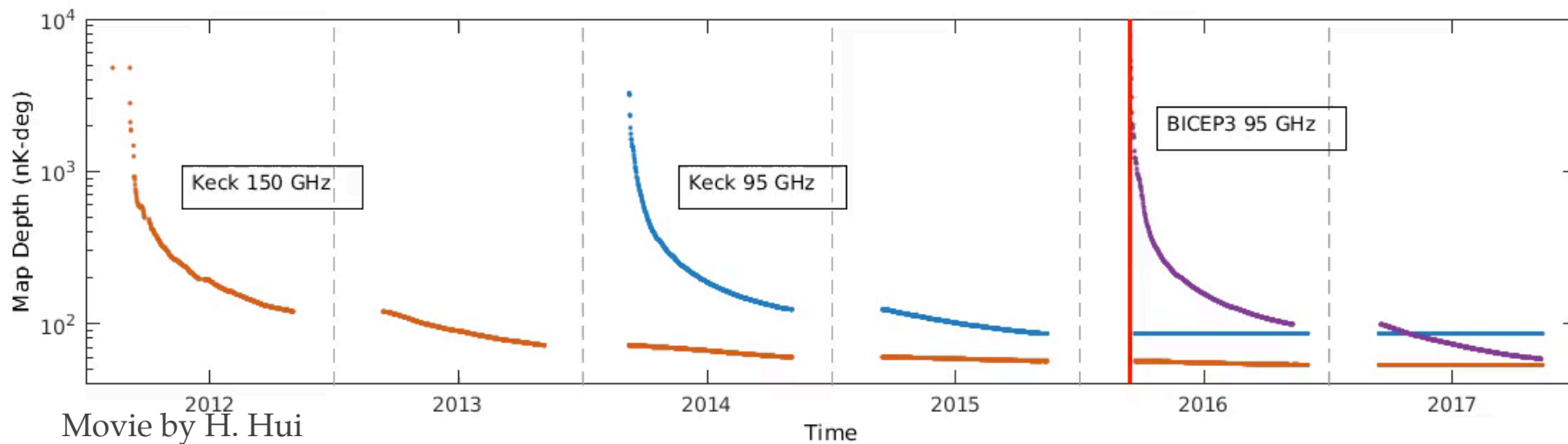
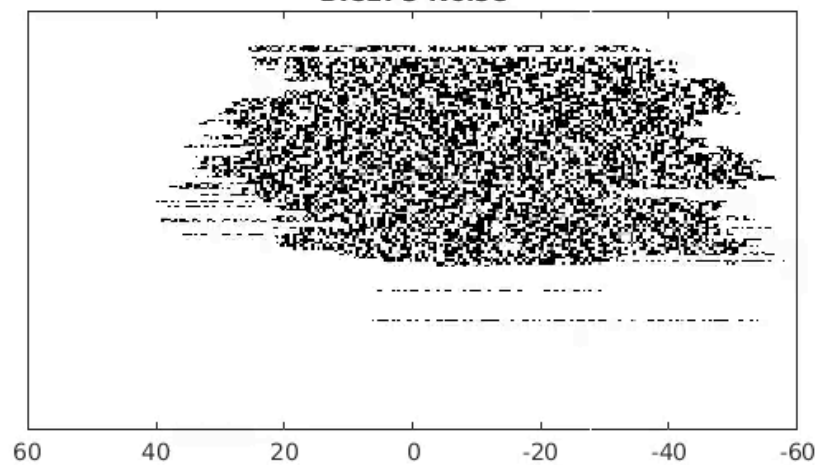

BICEP Array development



Univ. of Minnesota highbay

BICEP Array + SPT-3G

Current $\sigma(r) = 0.02$
(BK15)

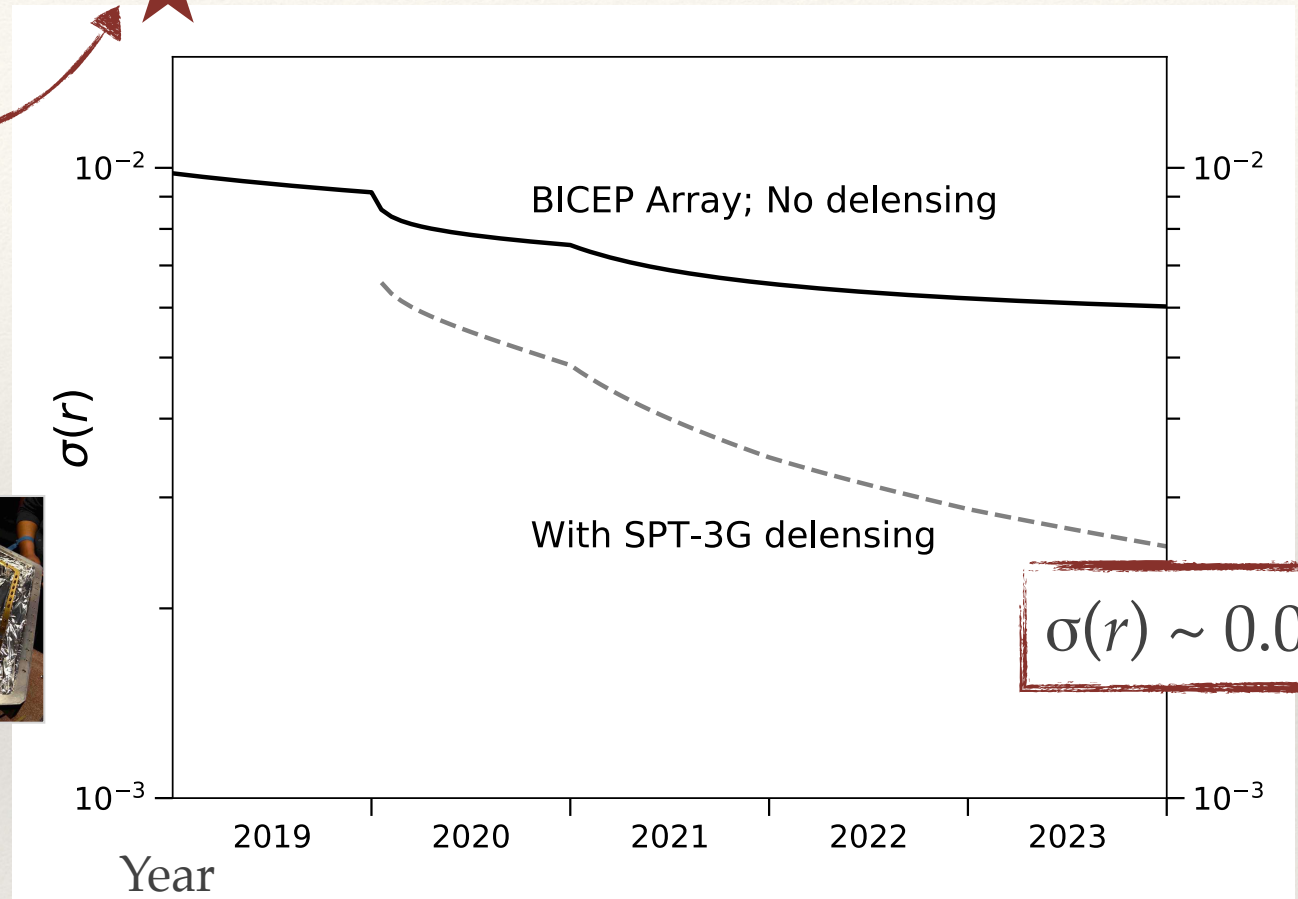
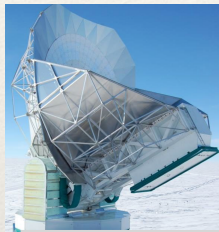
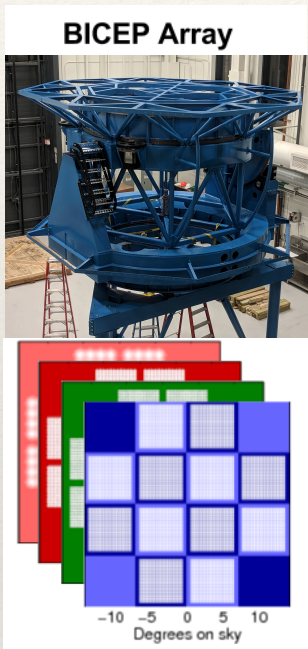

Assuming BK15 foreground model: $A_{\text{dust}}, \alpha_{\text{dust}}, \beta_{\text{dust}}, A_{\text{sync}}, \alpha_{\text{sync}}, \beta_{\text{sync}}$
 $\sigma(r)$ saturates without delensing even with the addition of 30/40 GHz and 220/280 GHz receivers in BICEP Array

Key takeaways:

- 1) CMB reconstructed ϕ will soon be competitive for delensing.
- 2) BICEP Array + SPT-3G delensing is projected to give $\sigma(r) \sim 0.003$ (7x current $\sigma(r)$).
- 3) Groundwork for next-generation experiment: CMB-S4!

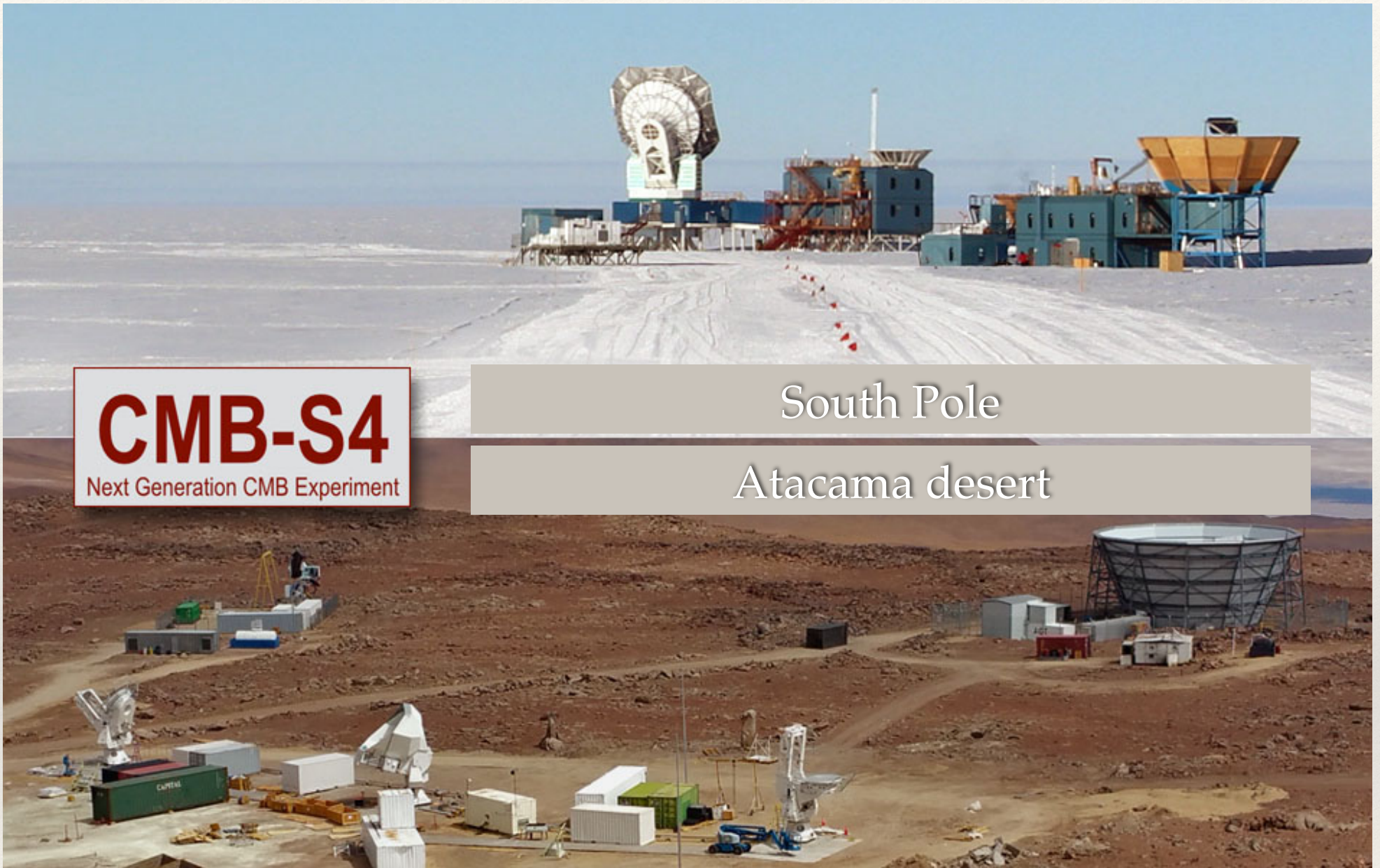

CMB-S4
Next Generation CMB Experiment

South Pole

Atacama desert

- ❖ ~500,000 detectors; begin survey ~2027
- ❖ deep survey (~3% sky) for r ; wide survey (> 40% sky) for survey/lensing science
- ❖ $\sigma(r) \sim 0.0005$; $\sigma(\sum m_\nu) < 20 \text{ meV}$

CMB-S4 Science Book (incl. KW)

ϕ reconstruction reach + $\sigma(\sum m_\nu)$ in CMB-S4

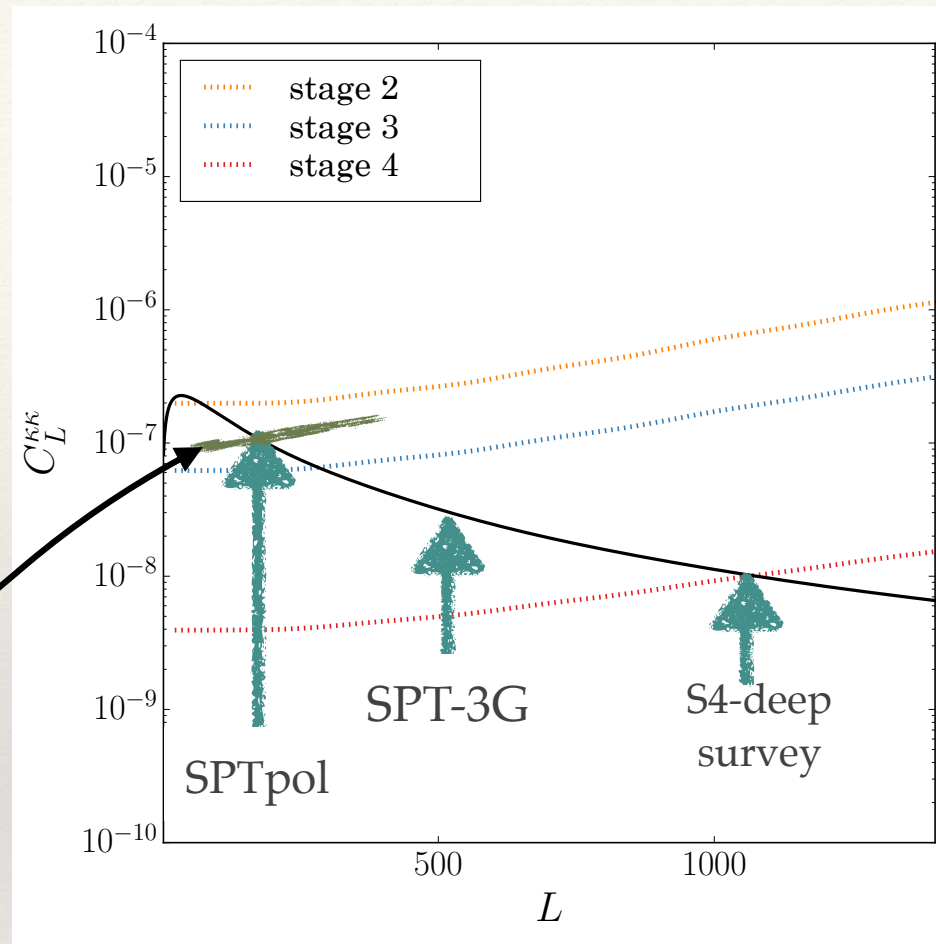
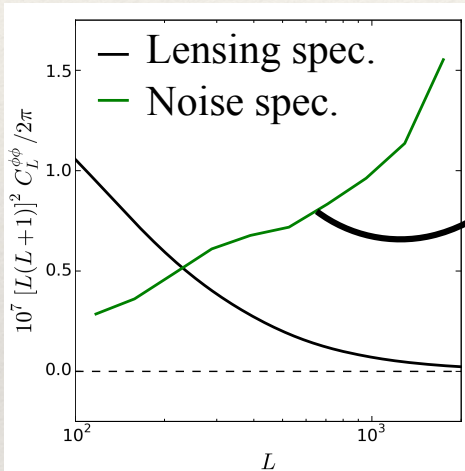

CMB-S4 Science Book (incl. KW)

- Individual ϕ modes below $L \sim 1000$ will be measured to $S/N > 1$ by CMB-S4.
- $\sigma(\sum m_\nu) < 20$ meV (with DESI BAO).

r forecast with CMB-S4

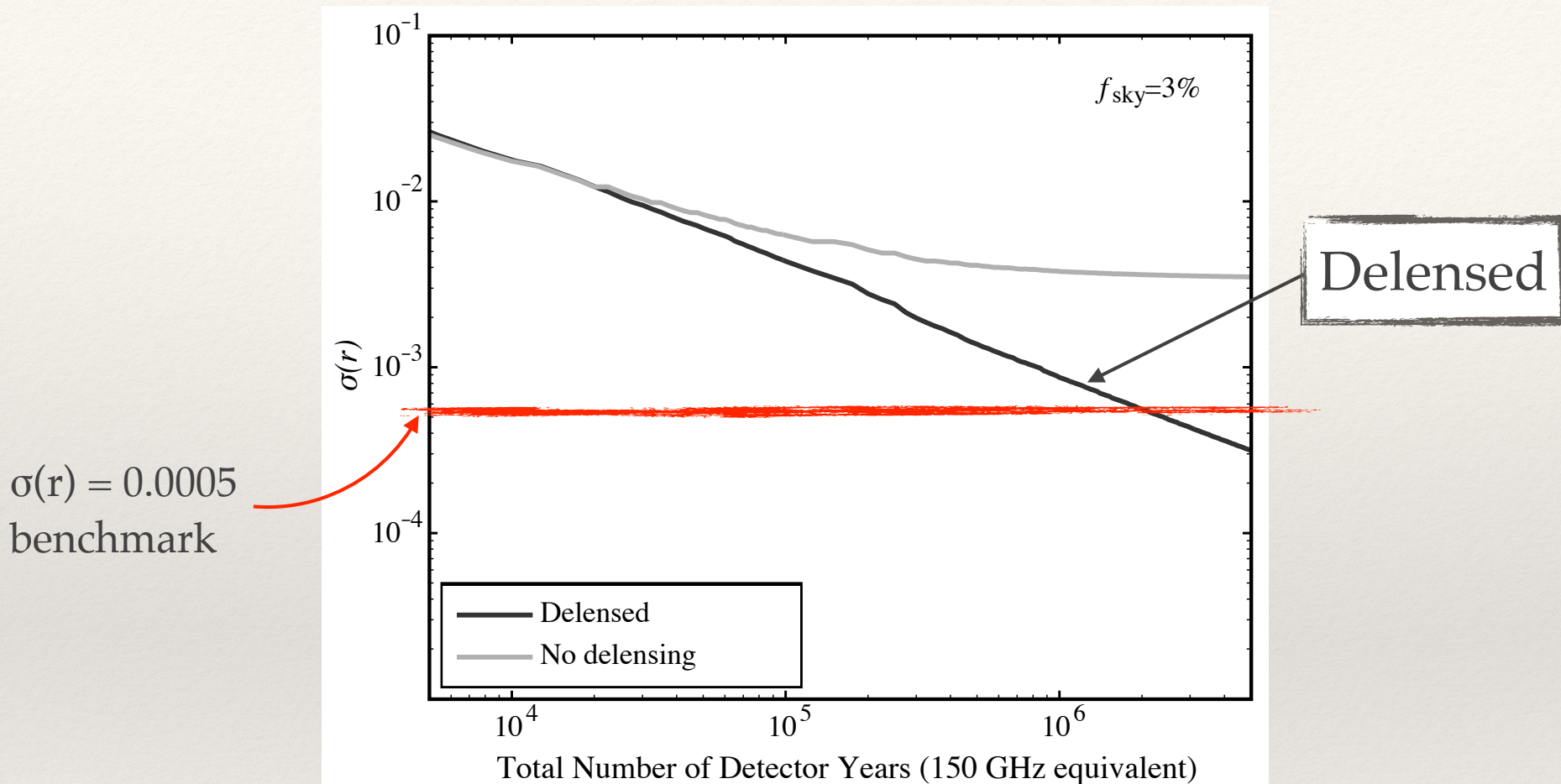

CMB-S4 Science Book (incl. KW)

Can't reach benchmark $\sigma(r)$ without delensing!

In high S/N regime, need much more detailed simulations to understand all real-world non-idealities that can bias our measurements.

Summary

- ❖ CMB B modes provide a unique window to early universe physics; e.g. tensor perturbation amplitude \rightarrow energy scale of inflation.
- ❖ Lensing B modes are one of the foregrounds of primordial B-mode measurements, and will be limiting the uncertainty of the r measurement $\sigma(r)$ in the next 2-3 years.
 - ❖ We have demonstrated a reduction of $\sigma(r)$ through delensing of BICEP / Keck simulations.
- ❖ CMB lensing is sensitive to structure growth \rightarrow neutrino masses.
- ❖ Delensing of BICEP Array maps using SPT-3G lensing potentials improves $\sigma(r)$ by 2-3x.
- ❖ Delensing is required for CMB-S4 to reach benchmark $\sigma(r) \sim 0.0005$. Optimal lensing estimators in active development currently!

Thank you for your attention



BICEP3 receiver, Dark Sector Lab, South Pole Station