



# Precision timing detector for CMS at the HL-LHC

*Artur Apresyan*

*SLAC Experimental Seminar*

*July 14, 2020*

# The Large Hadron Collider

Four large experiments: **ATLAS**, **CMS**, **ALICE**, and **LHCb**

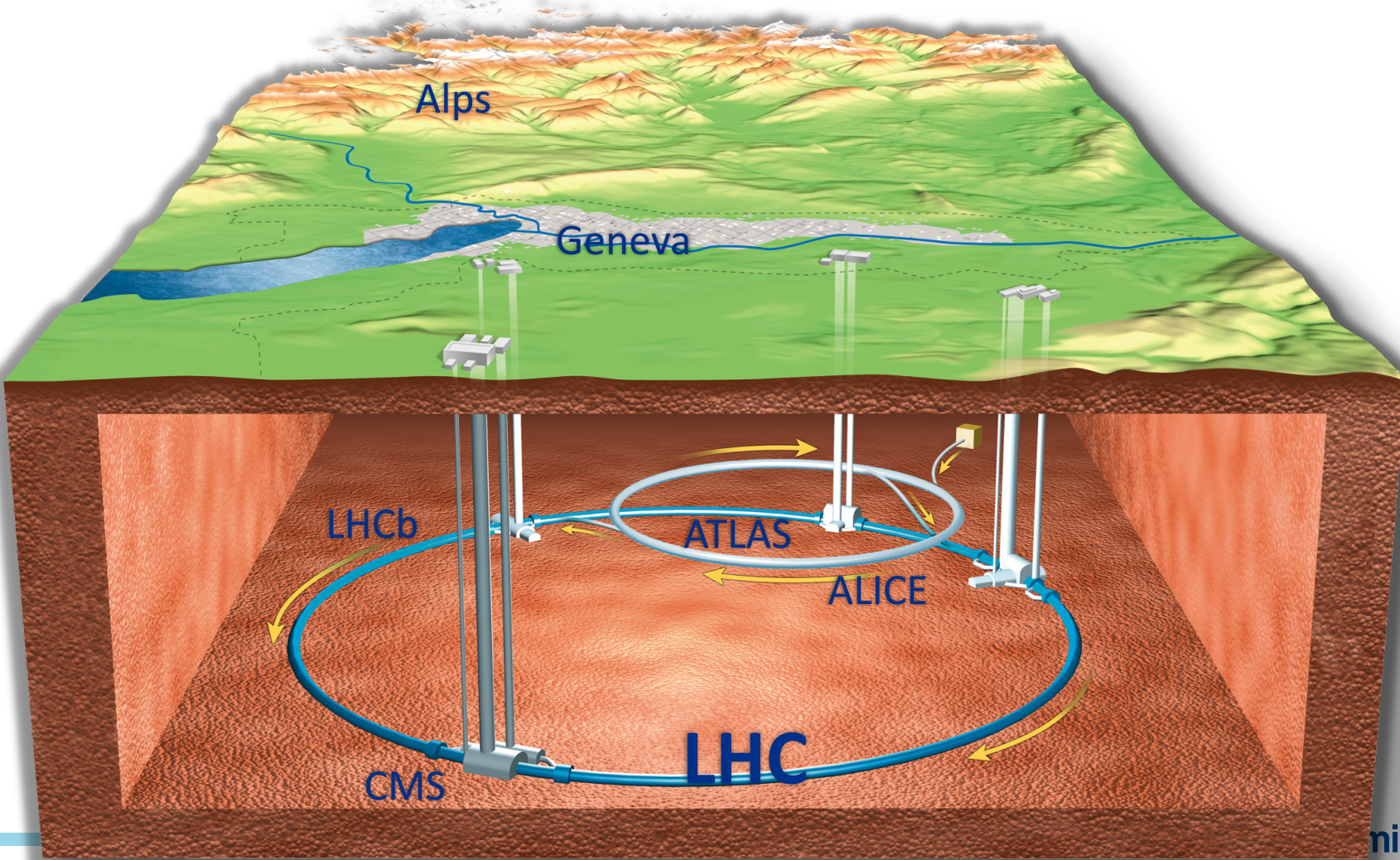

# The Large Hadron Collider

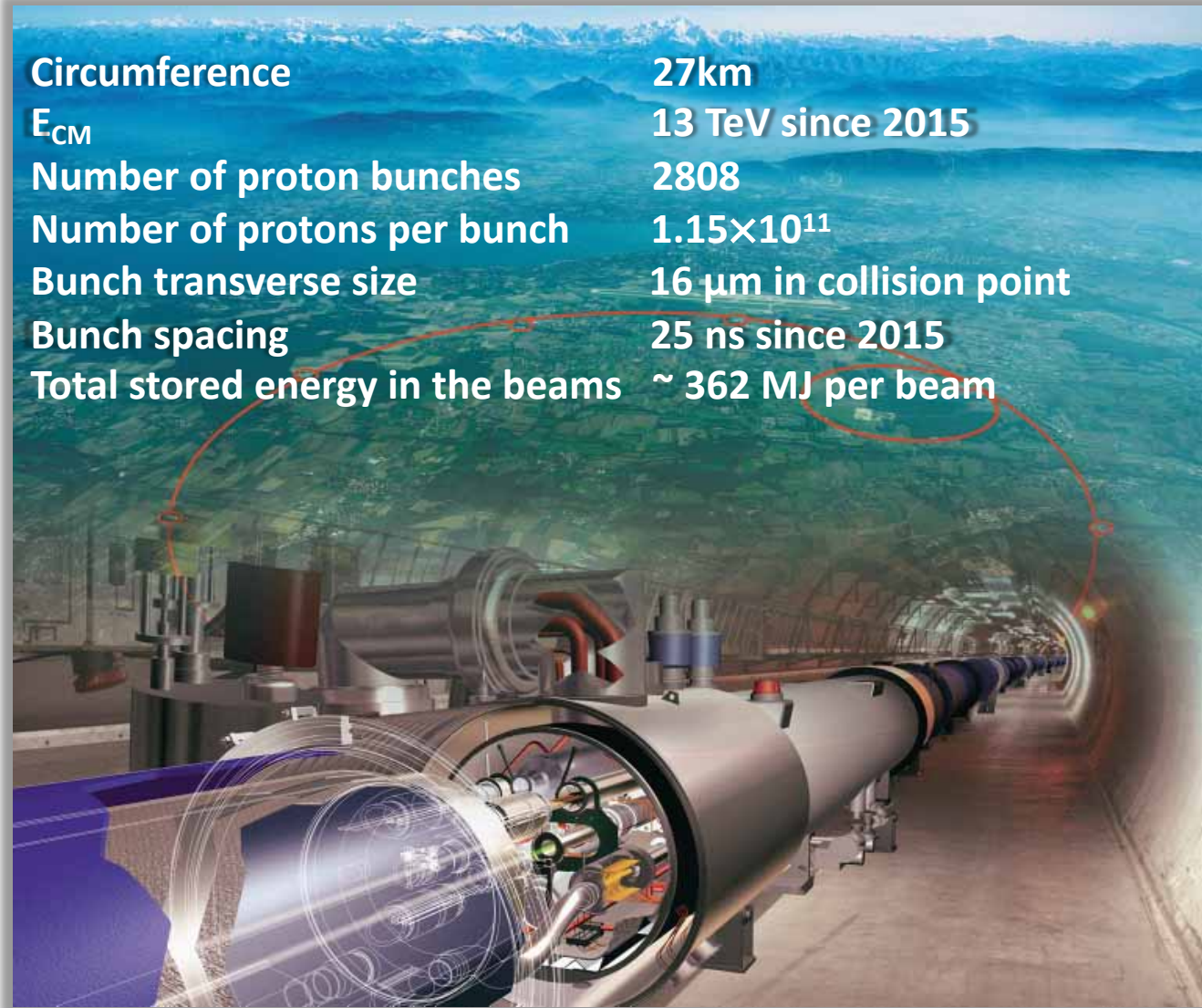

# The Large Hadron Collider

|                                  |                                     |
|----------------------------------|-------------------------------------|
| Circumference                    | 27km                                |
| $E_{\text{CM}}$                  | 13 TeV since 2015                   |
| Number of proton bunches         | 2808                                |
| Number of protons per bunch      | $1.15 \times 10^{11}$               |
| Bunch transverse size            | 16 $\mu\text{m}$ in collision point |
| Bunch spacing                    | 25 ns since 2015                    |
| Total stored energy in the beams | $\sim 362$ MJ per beam              |

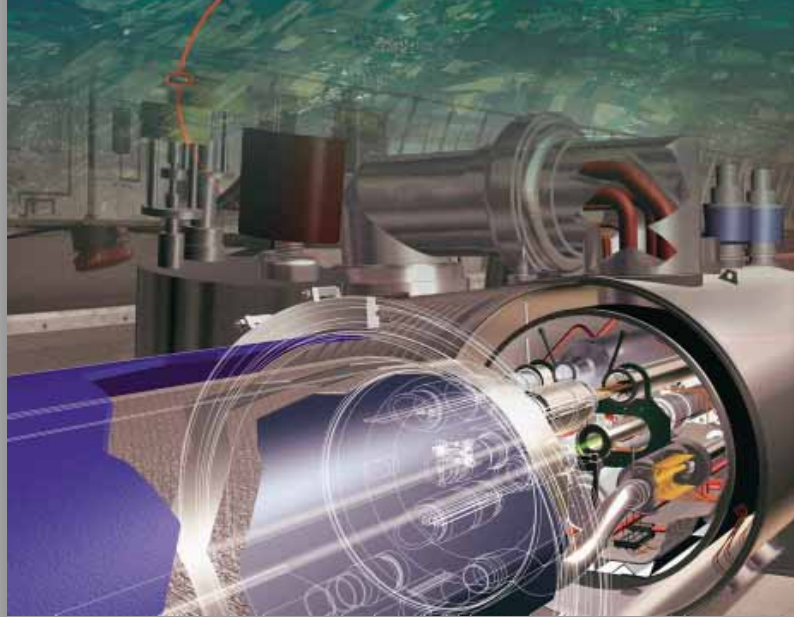

10,000-ton carrier at 30 km/h

# Proton-proton collisions

**78** *p-p collisions in the same bunch crossing*

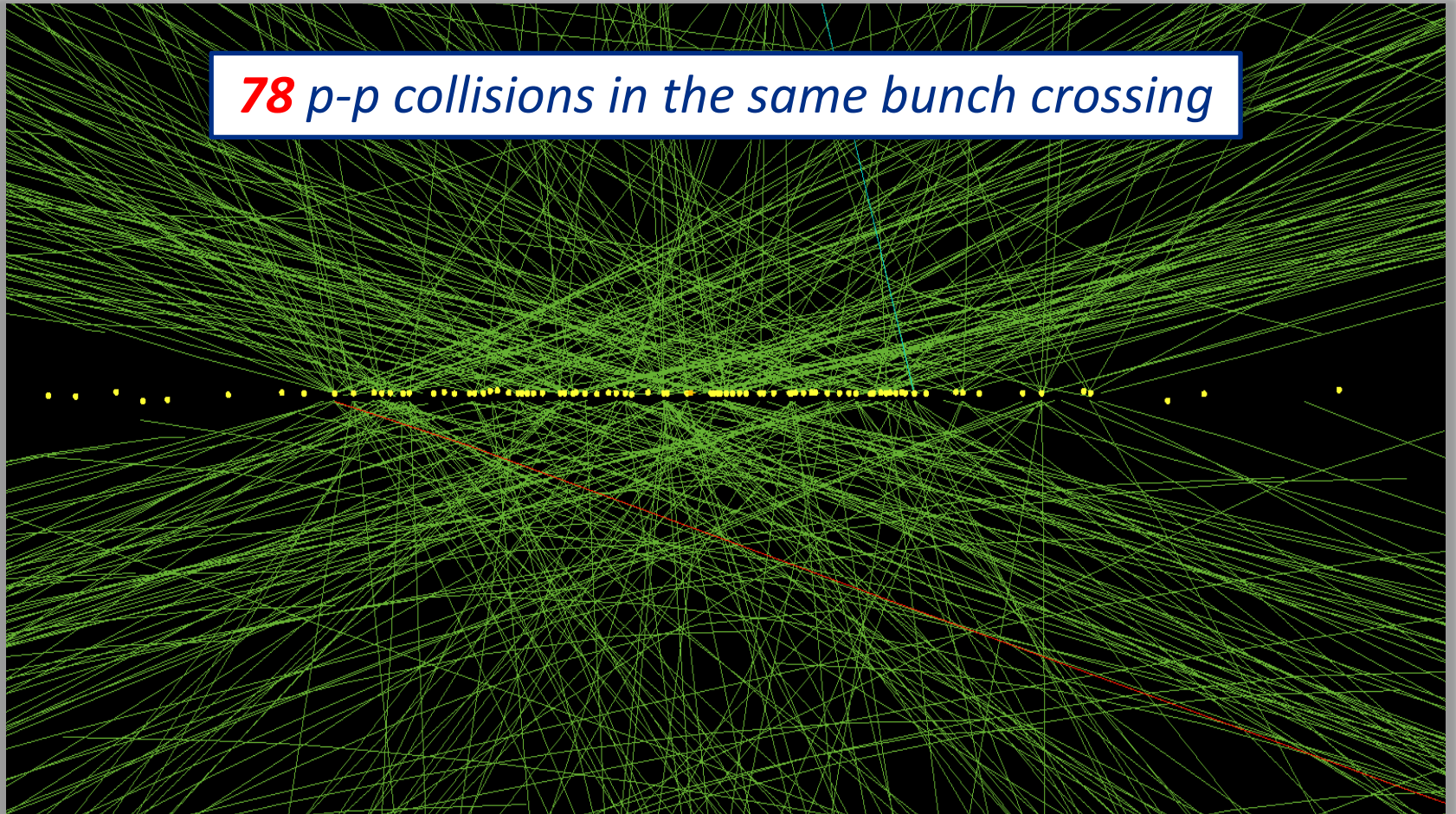

Collect lots of proton-proton collisions data

# The Compact Muon Solenoid (CMS)

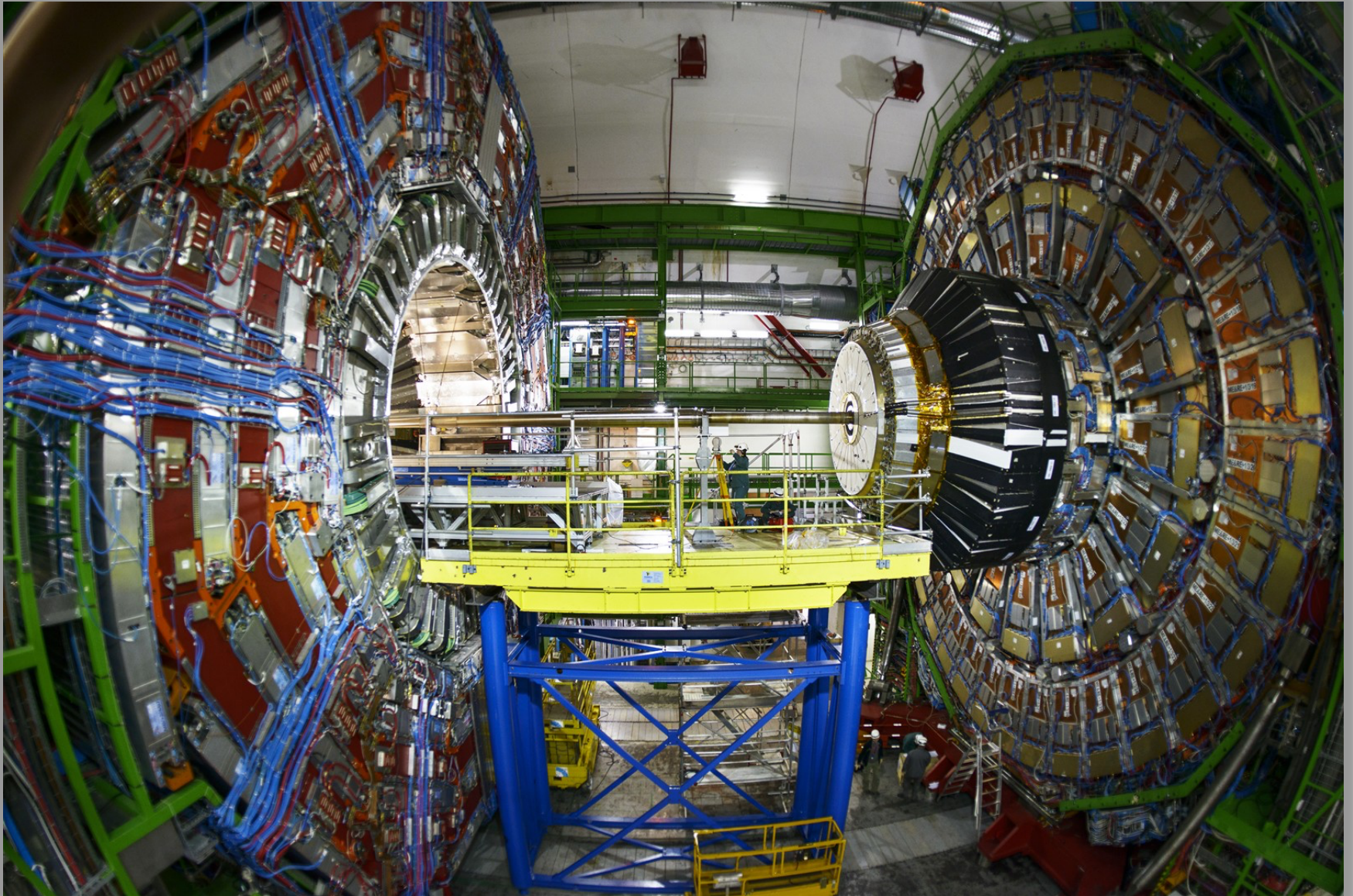

# The Compact Muon Solenoid (CMS)



**2700** physicists, **180** institutions from **43** countries



# The crown jewel

- The Higgs boson discovery announced in 2012

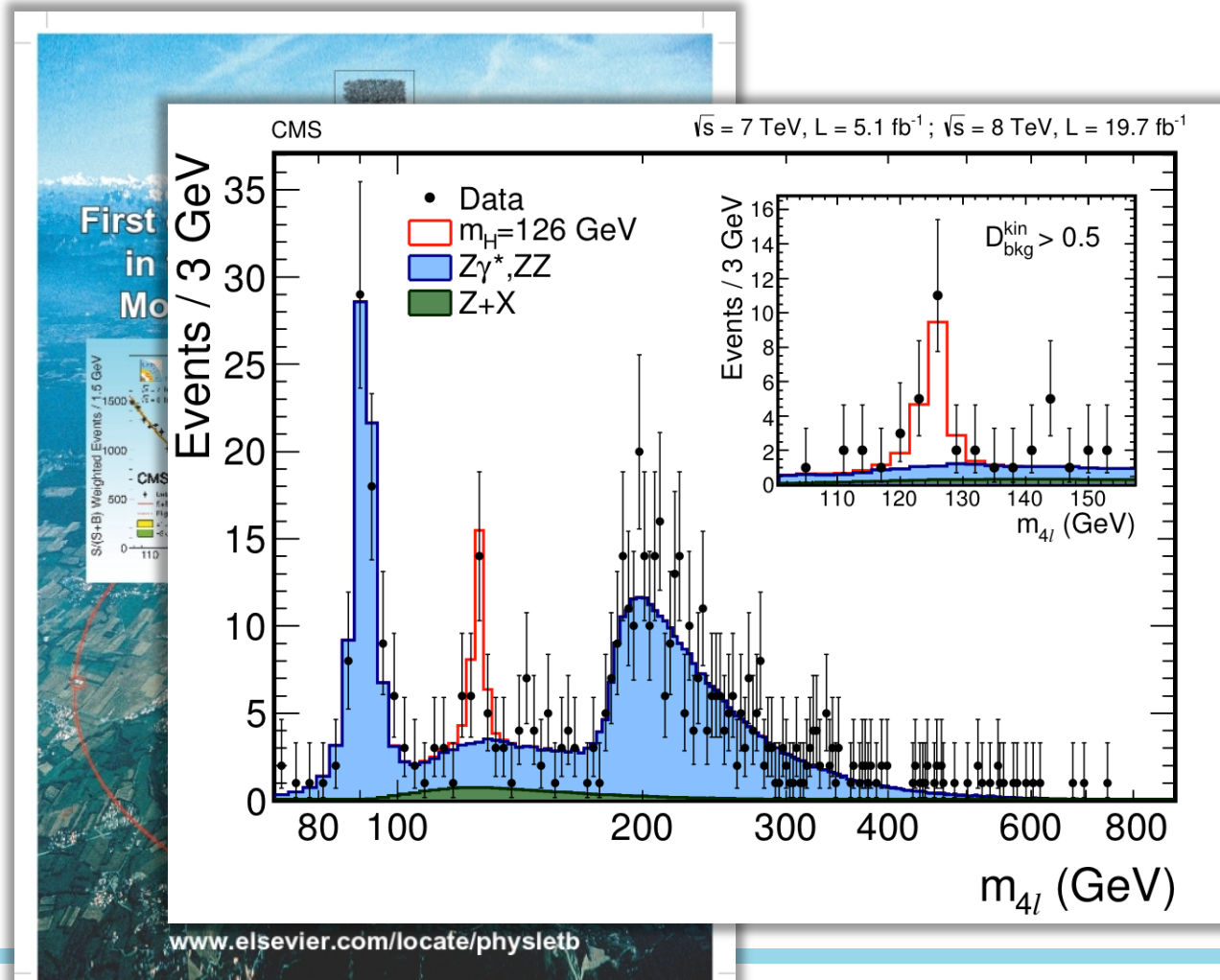

# The crown jewel

- The Higgs boson discovery announced in 2012

The image is a collage celebrating the Higgs boson discovery. It features a plot of 'Events / 3 GeV' vs 'Events / 3 GeV' with a peak at 125 GeV, a photo of two men shaking hands on a blue carpet, and a Nobel Prize medal.

Events / 3 GeV

Events / 3 GeV

First in Mo

St(S+B) Weighted Events / 1.5 GeV

1500

1000

500

0

110

125

130

135

140

145

150

155

160

165

170

175

180

185

190

195

200

205

210

215

220

225

230

235

240

245

250

255

260

265

270

275

280

285

290

295

300

305

310

315

320

325

330

335

340

345

350

355

360

365

370

375

380

385

390

395

400

405

410

415

420

425

430

435

440

445

450

455

460

465

470

475

480

485

490

495

500

505

510

515

520

525

530

535

540

545

550

555

560

565

570

575

580

585

590

595

600

605

610

615

620

625

630

635

640

645

650

655

660

665

670

675

680

685

690

695

700

705

710

715

720

725

730

735

740

745

750

755

760

765

770

775

780

785

790

795

800

805

810

815

820

825

830

835

840

845

850

855

860

865

870

875

880

885

890

895

900

905

910

915

920

925

930

935

940

945

950

955

960

965

970

975

980

985

990

995

1000

1005

1010

1015

1020

1025

1030

1035

1040

1045

1050

1055

1060

1065

1070

1075

1080

1085

1090

1095

1100

1105

1110

1115

1120

1125

1130

1135

1140

1145

1150

1155

1160

1165

1170

1175

1180

1185

1190

1195

1200

1205

1210

1215

1220

1225

1230

1235

1240

1245

1250

1255

1260

1265

1270

1275

1280

1285

1290

1295

1300

1305

1310

1315

1320

1325

1330

1335

1340

1345

1350

1355

1360

1365

1370

1375

1380

1385

1390

1395

1400

1405

1410

1415

1420

1425

1430

1435

1440

1445

1450

1455

1460

1465

1470

1475

1480

1485

1490

1495

1500

1505

1510

1515

1520

1525

1530

1535

1540

1545

1550

1555

1560

1565

1570

1575

1580

1585

1590

1595

1600

1605

1610

1615

1620

1625

1630

1635

1640

1645

1650

1655

1660

1665

1670

1675

1680

1685

1690

1695

1700

1705

1710

1715

1720

1725

1730

1735

1740

1745

1750

1755

1760

1765

1770

1775

1780

1785

1790

1795

1800

1805

1810

1815

1820

1825

1830

1835

1840

1845

1850

1855

1860

1865

1870

1875

1880

1885

1890

1895

1900

1905

1910

1915

1920

1925

1930

1935

1940

1945

1950

1955

1960

1965

1970

1975

1980

1985

1990

1995

2000

2005

2010

2015

2020

2025

2030

2035

2040

2045

2050

2055

2060

2065

2070

2075

2080

2085

2090

2095

2100

2105

2110

2115

2120

2125

2130

2135

2140

2145

2150

2155

2160

2165

2170

2175

2180

2185

2190

2195

2200

2205

2210

2215

2220

2225

2230

2235

2240

2245

2250

2255

2260

2265

2270

2275

2280

2285

2290

2295

2300

2305

2310

2315

2320

2325

2330

2335

2340

2345

2350

2355

2360

2365

2370

2375

2380

2385

2390

2395

2400

2405

2410

2415

2420

2425

2430

2435

2440

2445

2450

2455

2460

2465

2470

2475

2480

2485

2490

2495

2500

2505

2510

2515

2520

2525

2530

2535

2540

2545

2550

2555

2560

2565

2570

2575

2580

2585

2590

2595

2600

2605

2610

2615

2620

2625

2630

2635

2640

2645

2650

2655

2660

2665

2670

2675

2680

2685

2690

2695

2700

2705

2710

2715

2720

2725

2730

2735

2740

2745

2750

2755

2760

2765

2770

2775

2780

2785

2790

2795

2800

2805

2810

2815

2820

2825

2830

2835

2840

2845

2850

2855

2860

2865

2870

2875

2880

2885

2890

2895

2900

2905

2910

2915

2920

2925

2930

2935

2940

2945

2950

2955

2960

2965

2970

2975

2980

2985

2990

2995

3000

3005

3010

3015

3020

3025

3030

3035

3040

3045

3050

3055

3060

3065

3070

3075

3080

3085

3090

3095

3100

3105

3110

3115

3120

3125

3130

3135

3140

3145

3150

3155

3160

3165

3170

3175

3180

3185

3190

3195

3200

3205

3210

3215

3220

3225

3230

3235

3240

3245

3250

3255

3260

3265

3270

3275

3280

3285

3290

3295

3300

3305

3310

3315

3320

3325

3330

3335

3340

3345

3350

3355

3360

3365

3370

3375

3380

3385

3390

3395

3400

3405

3410

3415

3420

3425

3430

3435

3440

3445

3450

3455

3460

3465

3470

3475

3480

3485

3490

3495

3500

3505

3510

3515

3520

3525

3530

3535

3540

3545

3550

3555

3560

3565

3570

3575

3580

3585

3590

3595

3600

3605

3610

3615

3620

3625

3630

3635

3640

3645

3650

3655

3660

3665

3670

3675

3680

3685

3690

3695

3700

3705

3710

3715

3720

3725

3730

3735

3740

3745

3750

3755

3760

3765

3770

3775

3780

3785

3790

3795

3800

3805

3810

3815

3820

3825

3830

3835

3840

3845

3850

3855

3860

3865

3870

3875

3880

3885

3890

3895

3900

3905

3910

3915

3920

3925

3930

3935

3940

3945

3950

3955

3960

3965

3970

3975

3980

3985

3990

3995

4000

4005

4010

4015

4020

4025

4030

4035

4040

4045

4050

4055

4060

4065

4070

4075

4080

4085

4090

4095

4100

4105

4110

4115

4120

4125

4130

4135

4140

4145

4150

4155

4160

4165

4170

4175

4180

4185

4190

4195

4200

4205

4210

4215

4220

4225

4230

4235

4240

4245

4250

4255

4260

4265

4270

4275

4280

4285

4290

4295

4300

4305

4310

4315

4320

4325

4330

4335

4340

4345

4350

4355

4360

4365

4370

4375

4380

4385

4390

4395

4400

4405

4410

4415

4420

4425

4430

4435

4440

4445

4450

4455

4460

4465

4470

4475

4480

4485

4490

4495

4500

4505

4510

4515

4520

4525

4530

4535

4540

4545

4550

4555

4560

4565

4570

4575

4580

4585

4590

4595

4600

4605

4610

4615

4620

4625

4630

4635

4640

4645

4650

4655

4660

4665

4670

4675

4680

4685

4690

4695

4700

4705

4710

4715

4720

4725

4730

4735

4740

4745

4750

4755

4760

4765

4770

4775

4780

4785

4790

4795

4800

4805

4810

4815

4820

4825

4830

4835

4840

4845

4850

4855

4860

4865

4870

4875

4880

4885

4890

4895

4900

4905

4910

4915

4920

4925

4930

4935

4940

4945

4950

4955

4960

4965

4970

4975

4980

4985

4990

4995

5000

5005

5010

5015

5020

5025

5030

5035

5040

5045

5050

5055

5060

5065

5070

5075

5080

5085

5090

5095

5100

5105

5110

5115

5120

5125

5130

5135

5140

5145

5150

5155

5160

5165

5170

5175

5180

5185

5190

5195

5200

5205

5210

5215

5220

5225

5230

5235

5240

5245

5250

5255

5260

5265

5270

5275

5280

5285

5290

5295

5300

5305

5310

5315

5320

5325

5330

5335

5340

5345

5350

5355

5360

5365

5370

5375

5380

5385

5390

5395

5400

5405

5410

5415

5420

5425

5430

5435

5440

5445

5450

5455

5460

5465

5470

5475

5480

5485

5490

5495

5500

5505

5510

5515

5520

5525

5530

5535

5540

5545

5550

5555

5560

5565

5570

5575

5580

5585

5590

5595

5600

5605

5610

5615

5620

5625

5630

5635

5640

5645

5650

5655

5660

5665

5670

5675

5680

5685

5690

5695

5700

5705

5710

5715

5720

5725

5730

5735

5740

5745

5750

5755

5760

5765

5770

5775

5780

5785

5790

5795

5800

5805

5810

5815

5820

5825

5830

5835

5840

5845

5850

5855

5860

5865

5870

5875

5880

5885

5890

5895

5900

5905

5910

5915

5920

5925

5930

5935

5940

5945

5950

5955

5960

5965

5970

5975

5980

5985

5990

5995

6000

6005

6010

6015

6020

6025

6030

6035

6040

6045

6050

6055

6060

6065

6070

6075

6080

6085

6090

6095

6100

6105

6110

6115

6120

6125

6130

6135

6140

6145

6150

6155

6160

6165

6170

6175

6180

6185

6190

6195

6200

6205

6210

6215

6220

6225

6230

6235

6240

6245

6250

6255

6260

6265

6270

6275

6280

6285

6290

6295

6300

6305

6310

6315

6320

6325

6330

6335

6340

6345

6350

6355

6360

6365

6370

6375

6380

6385

6390

6395

6400

6405

6410

6415

6420

6425

6430

6435

6440

6445

6450

6455

6460

6465

6470

6475

6480

6485

6490

6495

6500

6505

6510

6515

6520

6525

6530

6535

6540

6545

6550

6555

6560

6565

6570

6575

6580

6585

6590

6595

6600

6605

6610

6615

6620

6625

6630

6635

6640

6645

6650

6655

6660

6665

6670

6675

6680

6685

6690

6695

6700

6705

6710

6715

6720

6725

6730

6735

6740

6745

6750

6755

6760

6765

6770

6775

6780

6785

6790

6795

6800

6805

6810

6815

6820

6825

6830

6835

6840

6845

6850

6855

6860

6865

6870

6875

6880

6885

6890

6895

6900

6905

6910</

# CMS Publications

Buttons for publication categories: Show all, Total, Exotica, Standard Model, Supersymmetry, Higgs, Top, Heavy Ions, B and Quarkonia, Forward and Soft QCD, Beyond 2 Generations, Detector Performance.

977 collider data papers submitted as of 2020-06-25

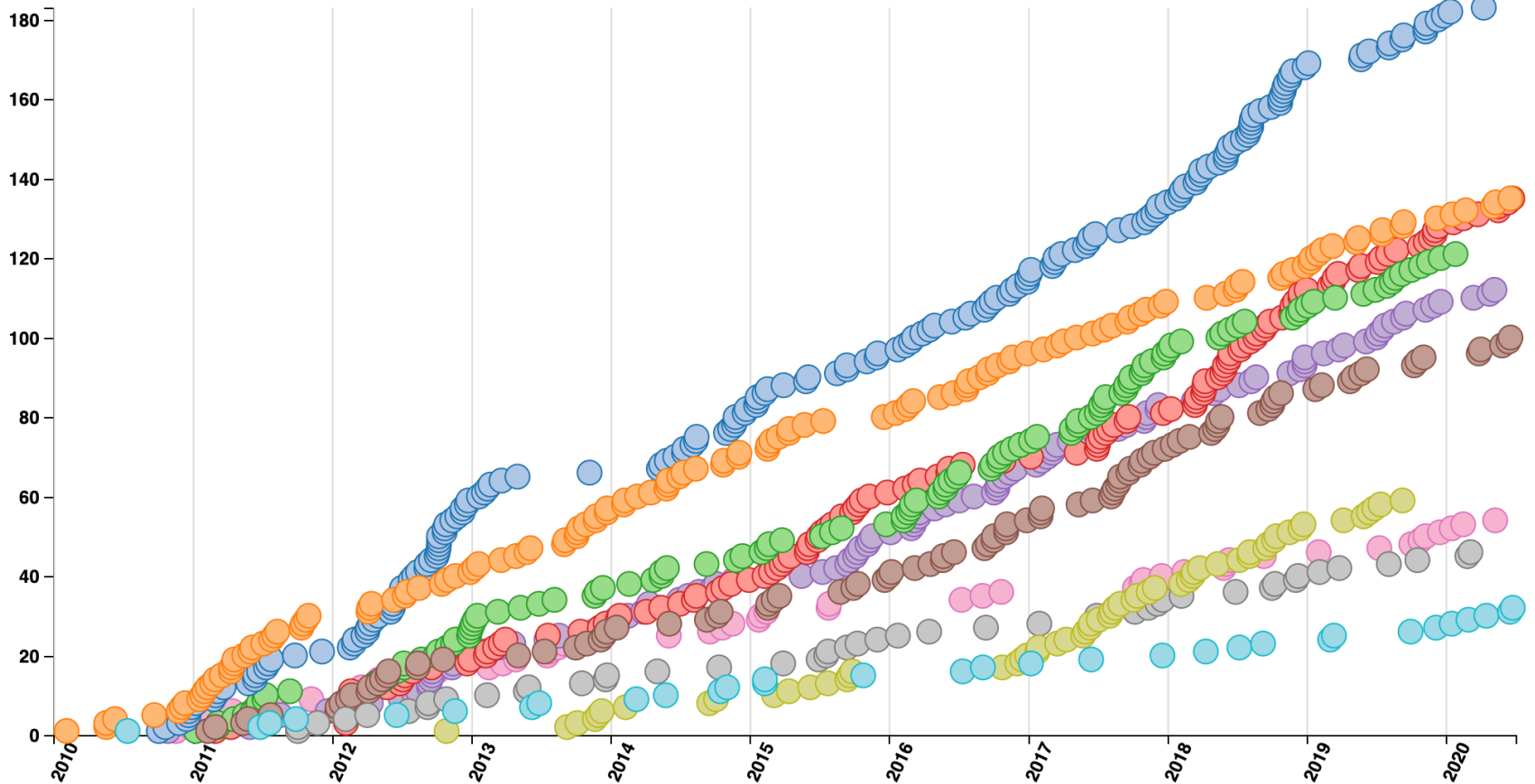

# CMS Publications

- Show all
- Total
- Exotica
- Standard Model
- Supersymmetry
- Higgs
- Top
- Heavy Ions
- B and Quarkonia
- Forward and Soft QCD
- Beyond 2 Generations
- Detector Performance

977 collider data papers submitted as of 2020-06-25

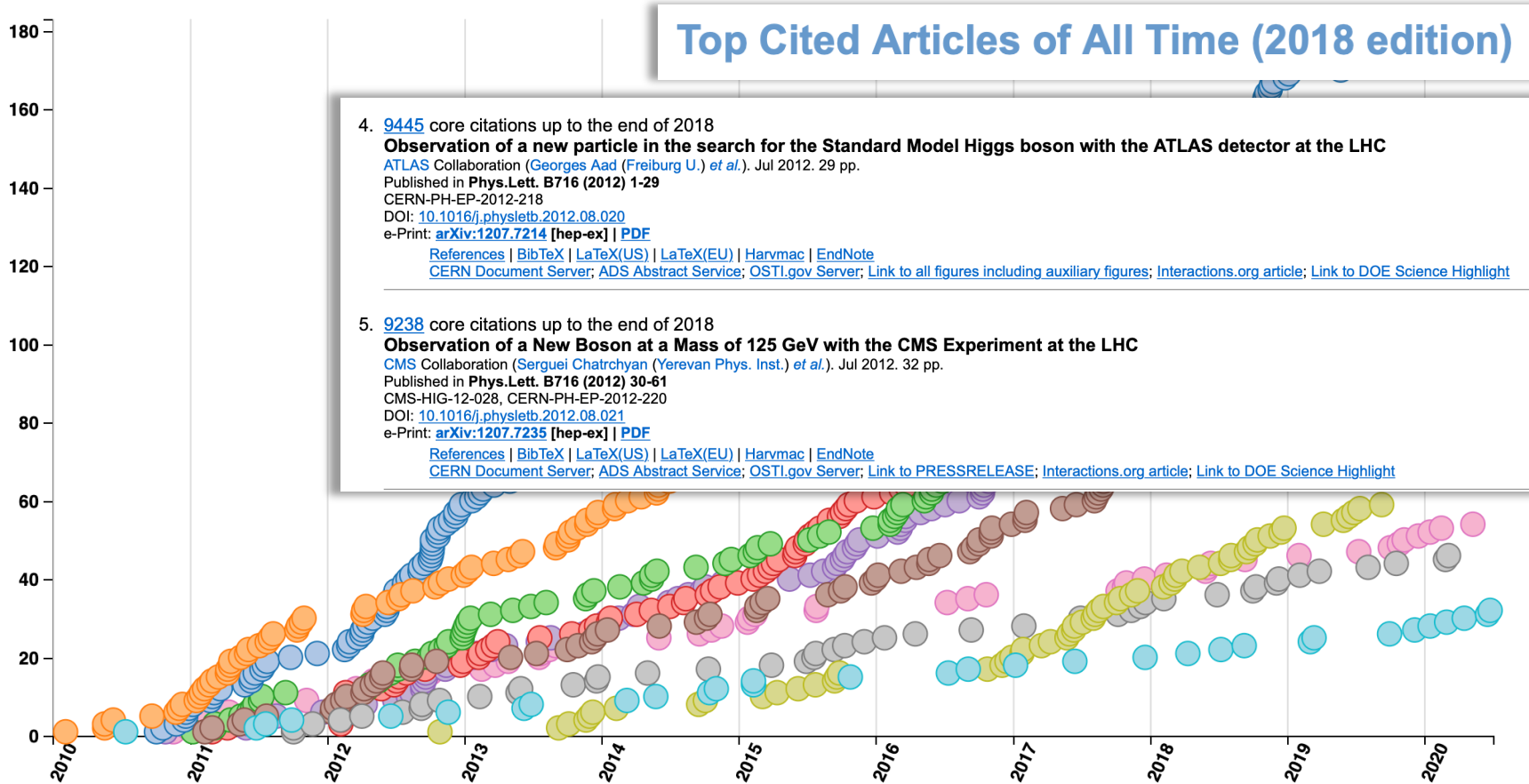

# What can Tera-scale teach us?

- The LHC: a tool to explore the structure of matter on a scale that is an order of magnitude smaller than previously achieved
- We need to use all its potential to explore all the corners accessible

## Seeing the infinitely small

Instruments at the Musée d'histoire des sciences of Geneva trace the history of microscopy



# Extend the reach

- How can we increase the reach of searches?
  - Increase collisions to a **higher energy**
  - Take much **more data** with the existing machine
- Since we have not found it yet, New Physics is a **low rate process**
  - High instantaneous luminosity is required, well in excess of current LHC
- Need to advance detector technologies to reap all physics from the future machines



# LHC & Future Colliders

- Luminosities in excess of  $10^{34} \text{ cm}^{-2}\text{s}^{-1}$  is required
  - HL-LHC : towards  $10^{35} \text{ cm}^{-2}\text{s}^{-1}$
  - Future Higher Energy Colliders: **even higher to probe even more rare processes: up to 1000 pileup**

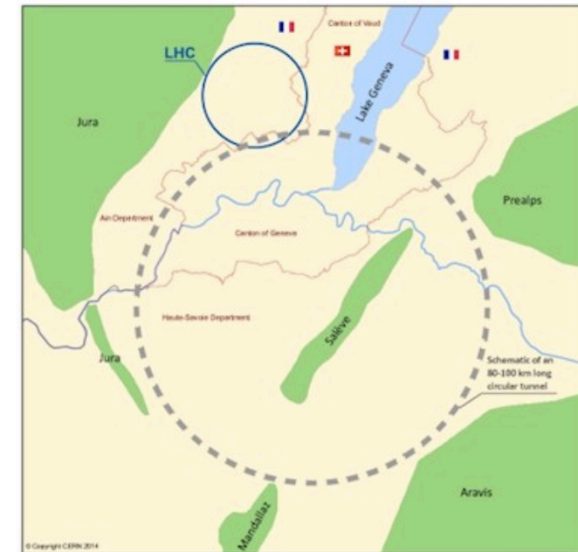

Google earth

# High Luminosity $\rightarrow$ High Pileup!

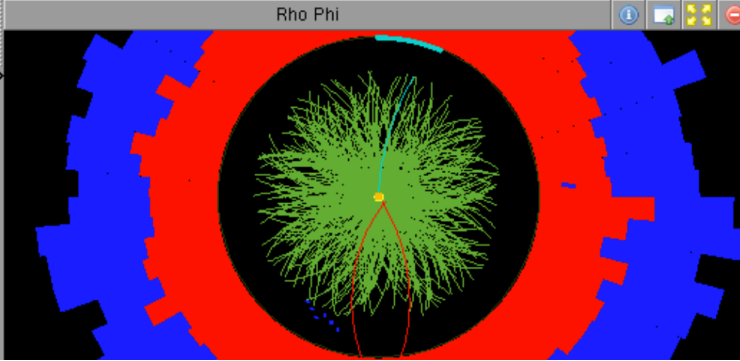
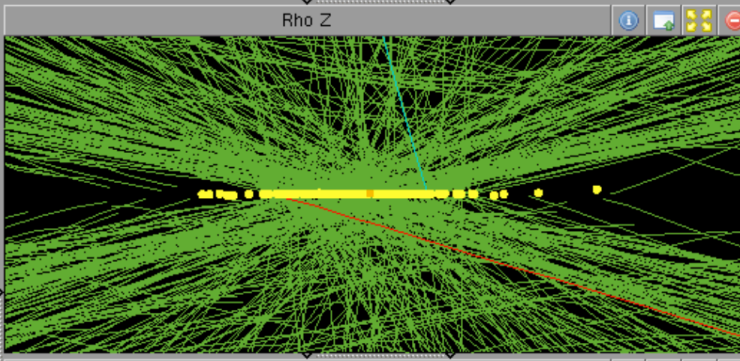
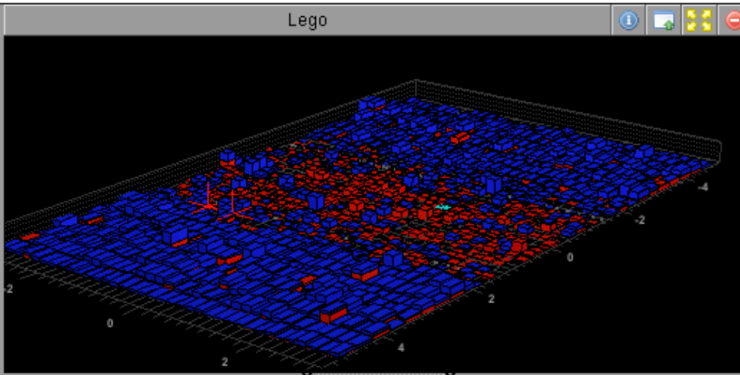
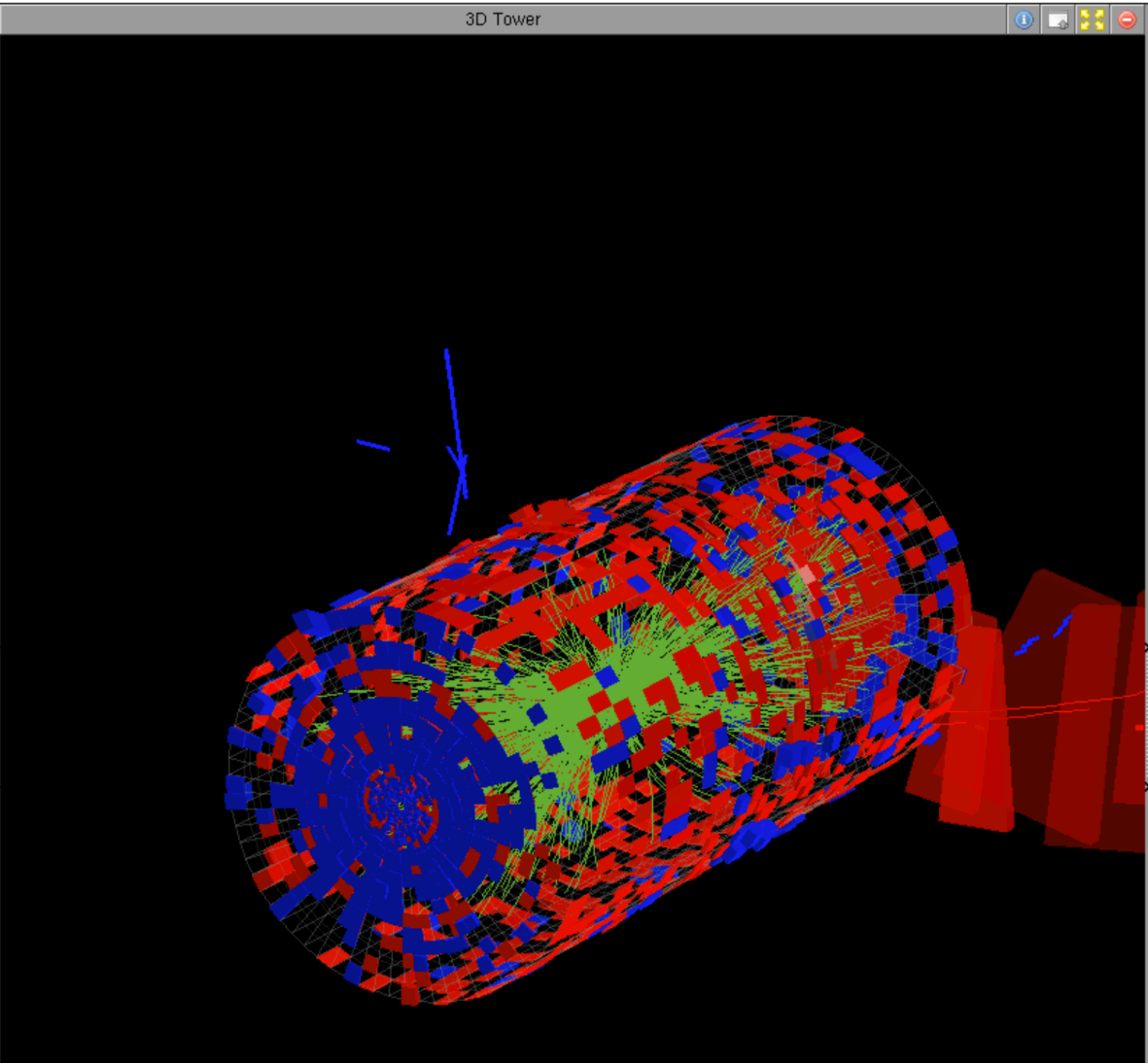

# HL-LHC upgrades schedule

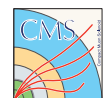

# HL-LHC Luminosity scenarios

- Leveling luminosity:
  - $5.3 \times 10^{34} \text{ cm}^{-2}\text{s}^{-1}$  and 140 pileup (**Baseline**)
  - $7.6 \times 10^{34} \text{ cm}^{-2}\text{s}^{-1}$  and 200 pileup (**Ultimate**)
- Collect 3 to 4  $\text{ab}^{-1}$  of pp data at 14 TeV

| Scenario     | Max. PU [events/xing] | Max. PU density [events /xing/mm] | Luminous Region long. r.m.s. size [cm] | $\Delta L_{\text{int}}/L_{\text{nom}}$ [%] | Additional HW [Y/N] |
|--------------|-----------------------|-----------------------------------|--|--|---------------------|
| Nominal      | 140                   | 1.3                               | <4.8                                   | 0  | N                   |
| Ultimate     | 200                   | 1.9                               | <4.5                                   | +33  | N                   |
| 8b+4e        | 140                   | 1.3                               | <5                                     | -25  | N                   |
| 200 MHz      | 140                   | 1.3                               | <4.8                                   | -14  | Y                   |
| Flat         | 140                   | 1.1                               | <5.5                                   | 0  | May be              |
| Crab kissing | 140                   | 0.6-0.65                          | <7                                     | -5   | Y                   |

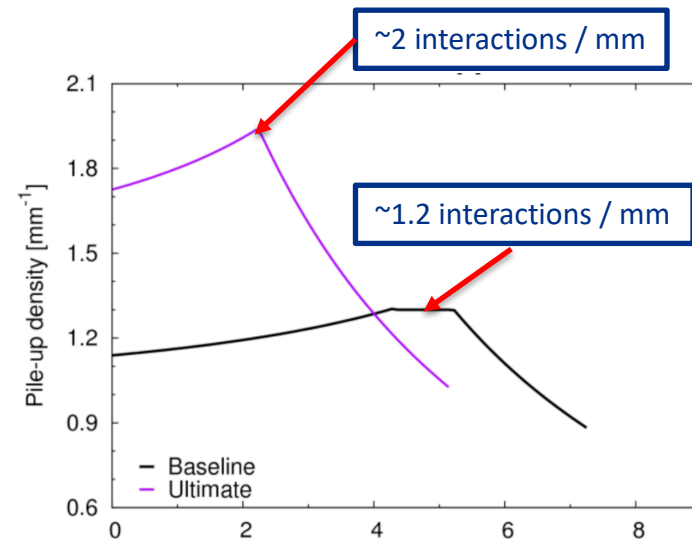

G. Arduini, R. Thomas, ECFA 2016

# HL-LHC beam spread

- Beamspot width in time is several hundred ps (**RMS = 200 ps**)
  - A detector with 20-30 psec timing resolution could meaningfully distinguish between interactions on the basis of timing

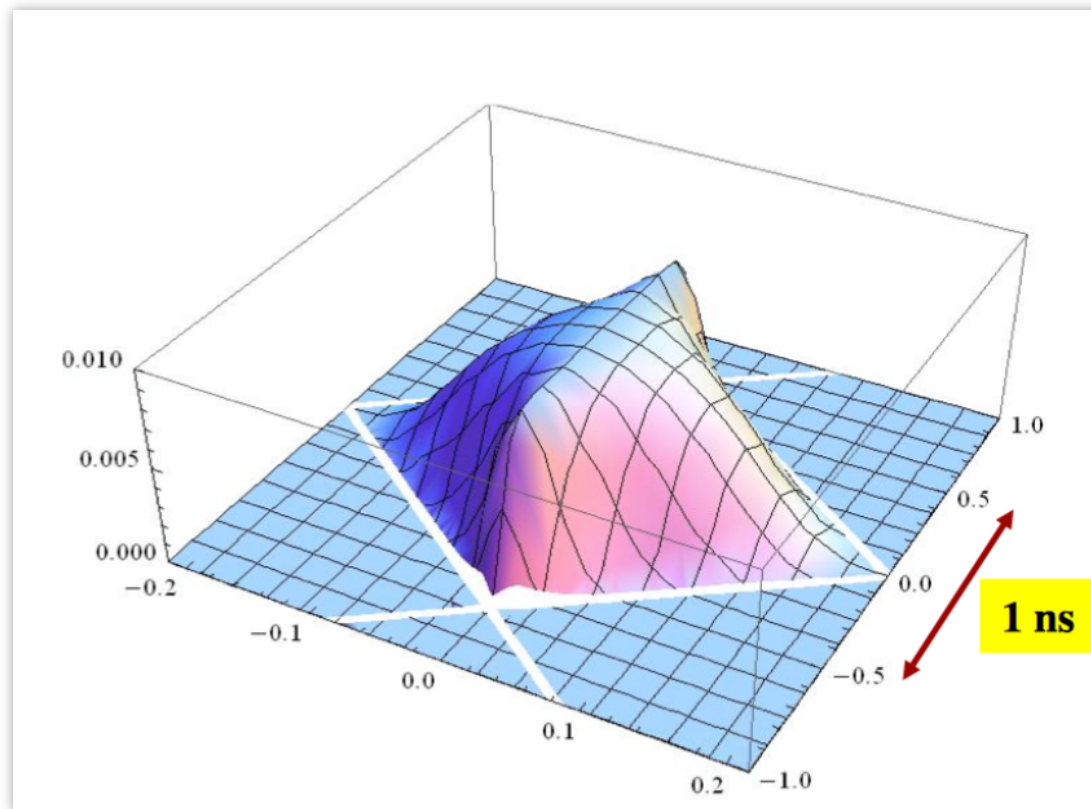

# The Challenge of the HL-LHC era

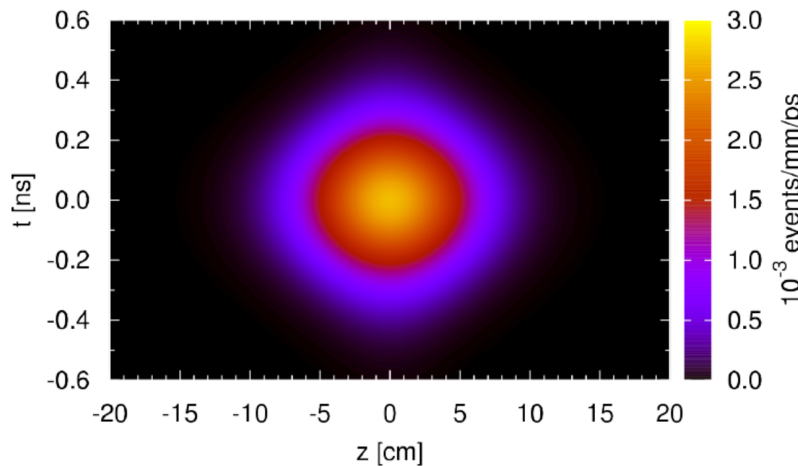
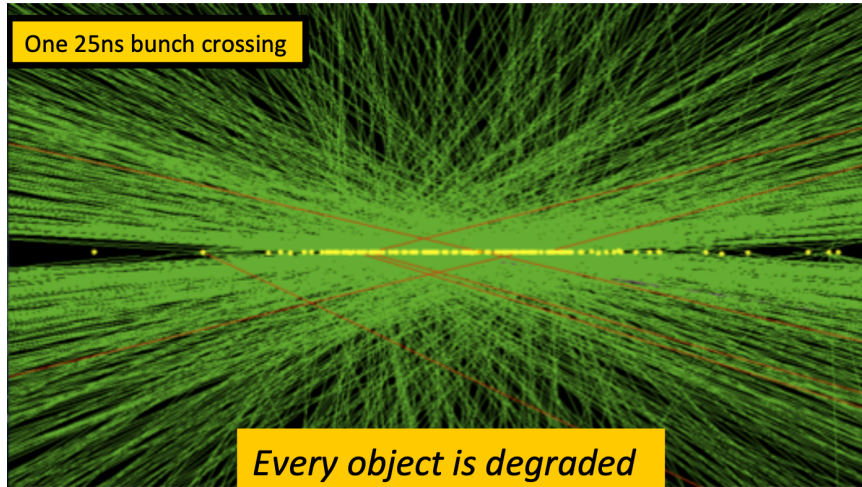

- Dealing with the effects of pileup interactions will be a major challenge of the HL-LHC era
  - PU interactions are separable in space + time.
- Imagine separating the 25ns beam crossing into consecutive time slices
  - Each exposure has far fewer vertices than when integrating over an event's complete time profile.
- Per-particle timing provided by the MIP Timing Detector (MTD) allows 4D track and vertex reconstruction
  - PU reduced in each time slice
  - Every object is improved
  - Significant benefit to CMS physics program

# CMS Phase 2 Upgrades

## L1 Trigger/HLT/DAQ NSF and DOE

- L1 40 MHz in/750 kHz out with tracking for PF-like selection
- HLT 7.5 kHz out

Beam Radiation and Luminosity, Common Systems, Infrastructure

## Calorimeter Endcap DOE

- Si, Scint + SiPM in Pb-W-SS
- 3D shower imaging with precise timing

Also known as HGCAL

## Tracker

- Si Strip Outer Tracker designed for L1 Track Trigger DOE
- Pixelated Inner Tracker extends coverage to  $|\eta| < 3.8$  NSF

## Barrel Calorimeters NSF

- ECAL single crystal granularity in L1 Trigger with precise timing for  $e/\gamma$  at 30 GeV
- ECAL and HCAL new back-end electronics

## Muon Systems NSF

- DT & CSC new FE/BE readout
- New GEM/RPC  $1.6 < |\eta| < 2.4$
- Extended coverage to  $|\eta| < 3.0$

## MIP Timing Detector DOE

- $< 60$  ps resolution
- Barrel: Crystals + SiPMs
- Endcap: LGADs

Also known as "Timing Layer" (TL)

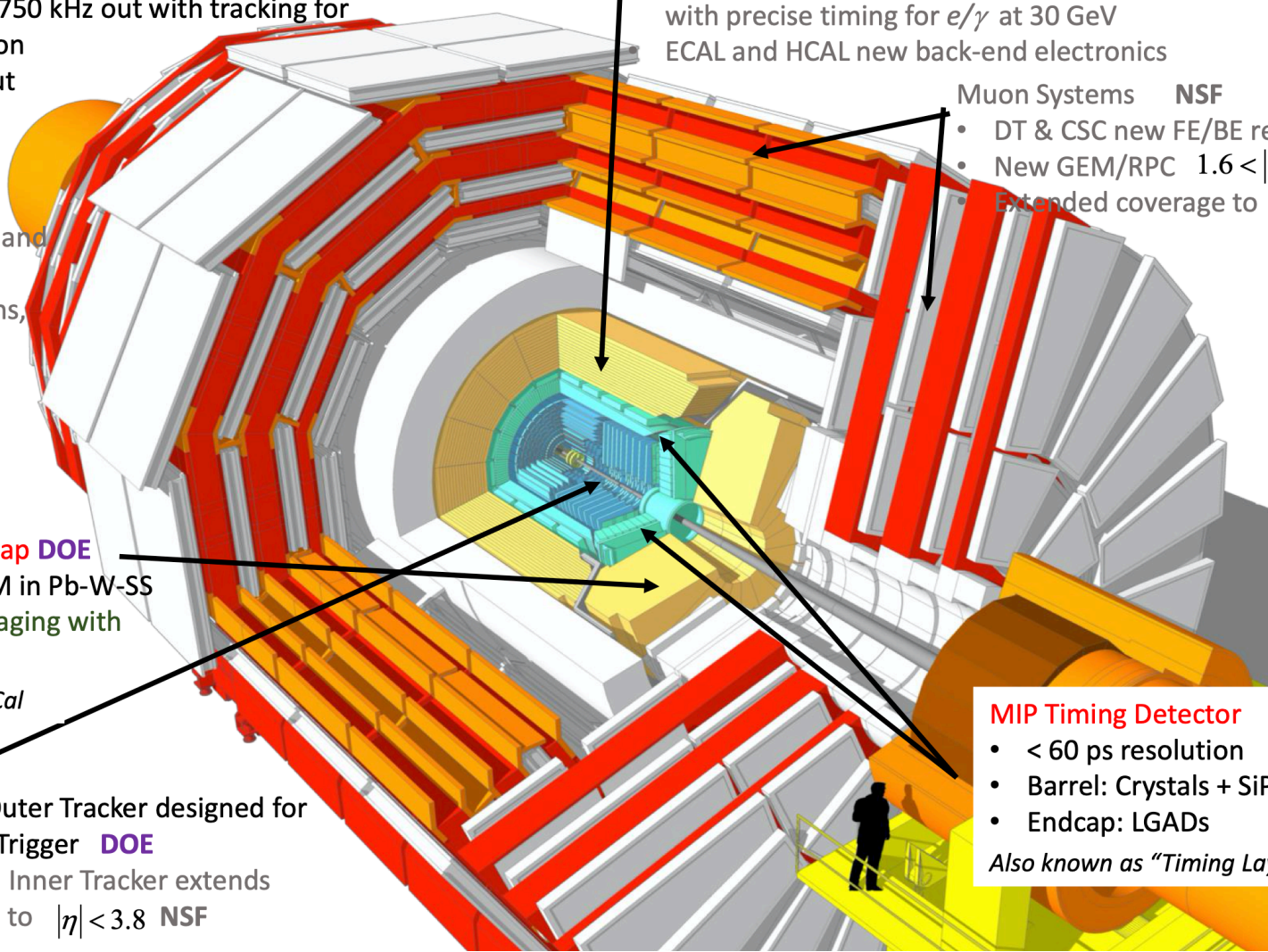

# CMS MIP timing detector (MTD)

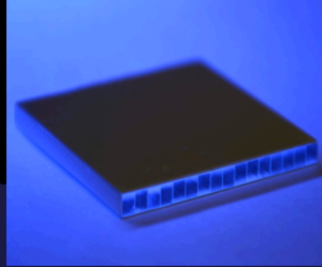

- BTL: L(Y)SO bars + SiPM readout:**
- TK/ ECAL interface  $\sim 45$  mm thick
  - $|\eta| < 1.45$  and  $p_T > 0.7$  GeV
  - Active area  $\sim 38$  m<sup>2</sup>; 332k channels
  - Fluence at  $3 \text{ ab}^{-1}$ :  $2 \times 10^{14} n_{\text{eq}}/\text{cm}^2$

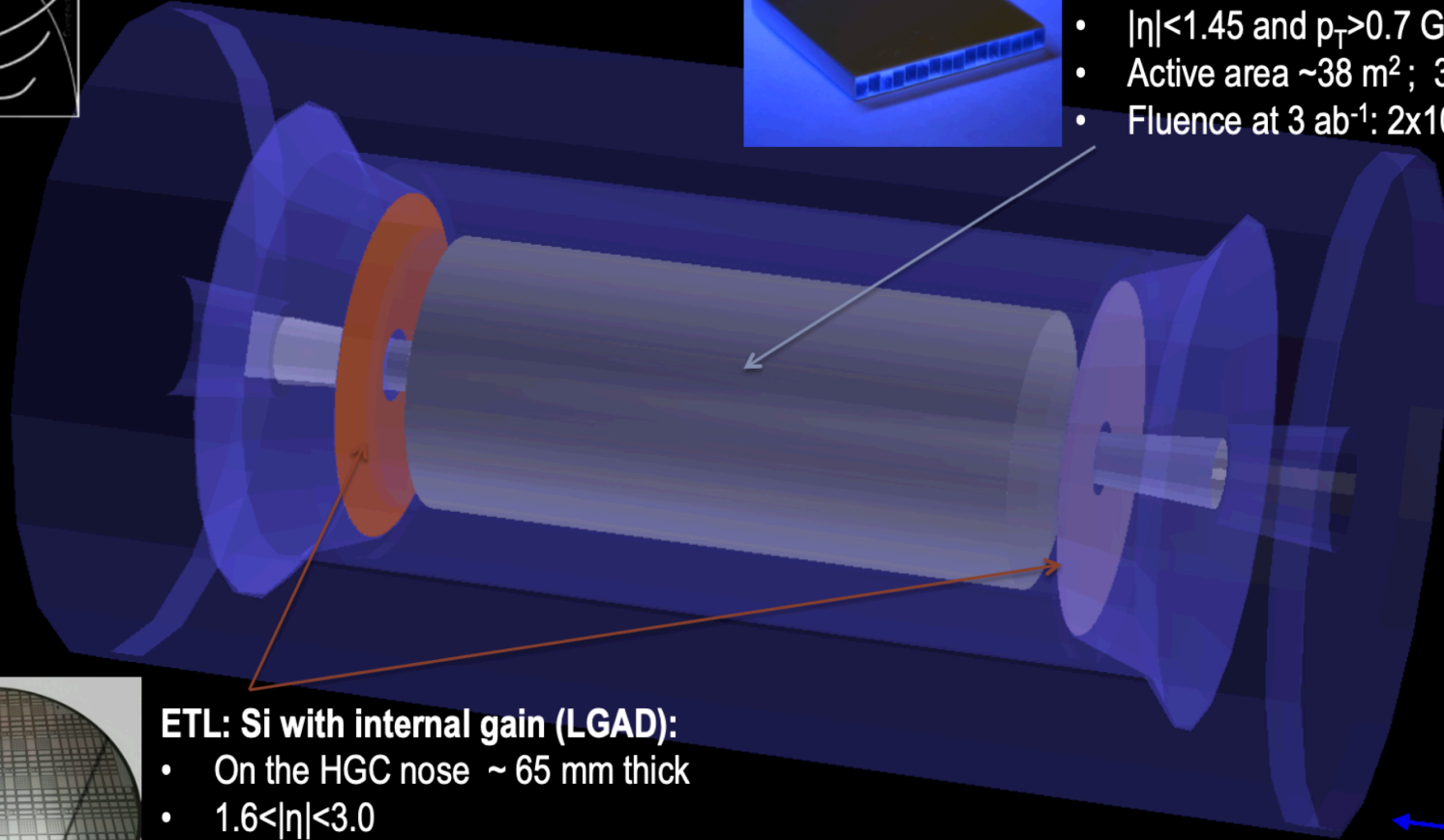

**ETL: Si with internal gain (LGAD):**

- On the HGC nose  $\sim 65$  mm thick
- $1.6 < |\eta| < 3.0$
- Active area  $\sim 14$  m<sup>2</sup>;  $\sim 8.5$ M channels
- Fluence at  $3 \text{ ab}^{-1}$ : up to  $2 \times 10^{15} n_{\text{eq}}/\text{cm}^2$

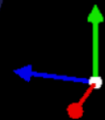
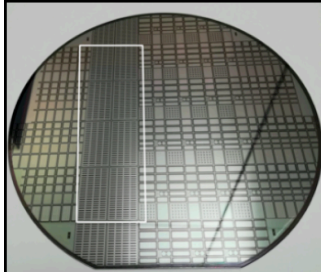

# Barrel Timing Layer (BTL) design

- LYSO crystals as scintillator with an excellent radiation tolerance and fast rise and decay times.
  - Attached to the inner wall of the Tracker Support Tube (TST).
  - 332k channels, organized in 6 Readout Units per tray.
- Time resolution of 35 ps at the beginning of lifetime and 60 ps by the end.

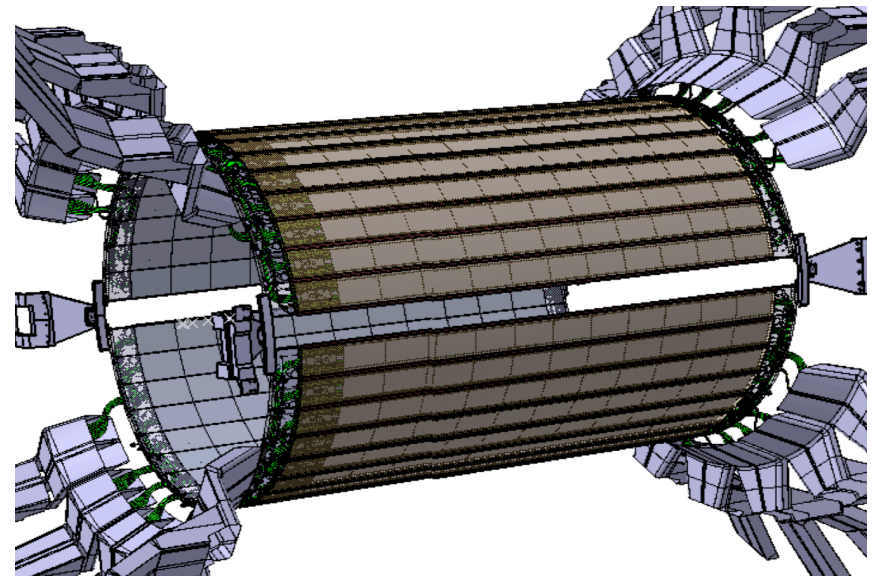
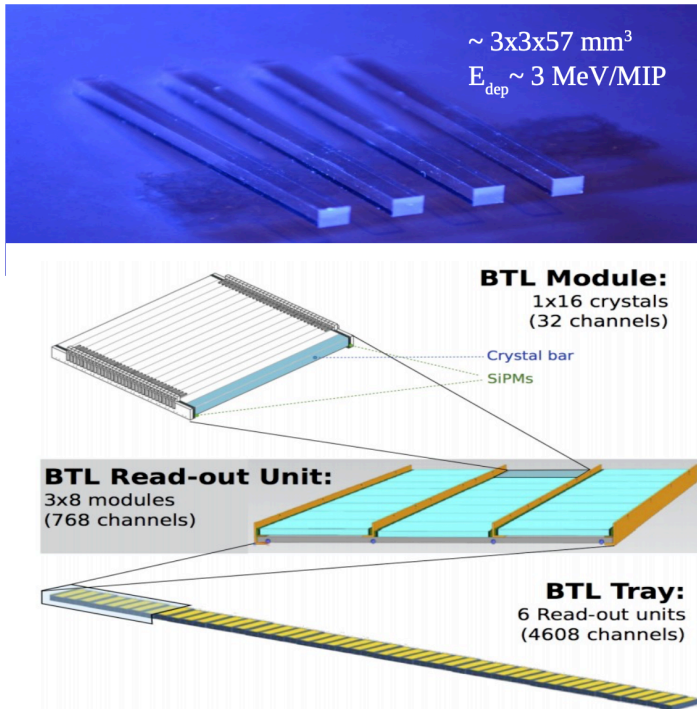

# Barrel Timing Layer (BTL) design

- Small SiPM cells: fast readout, robust vs. magnetic field/radiation and low power consumption.
- Readout using TOFHIR board with 6 ASICs each reading up to 16 crystals (32 channels).
  - Uniform time response and resolution in test-beams.
  - Improved resolution by combining the two SiPMs.

- 1: TOFHIR board with 6 ASICs
- 2: LYSO array with 16 LYSO bars, bars oriented in  $\phi$
- 3: Concentrator card
- 4: DCDC converter
- 5: CC-to-FE connector
- 6: IpGBT
- 7: SiPM-to-FE connector
- 8: Cooling bar with CO<sub>2</sub> pipes
- 9: Cooling fins

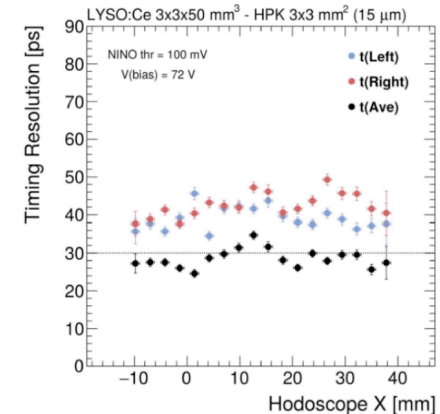
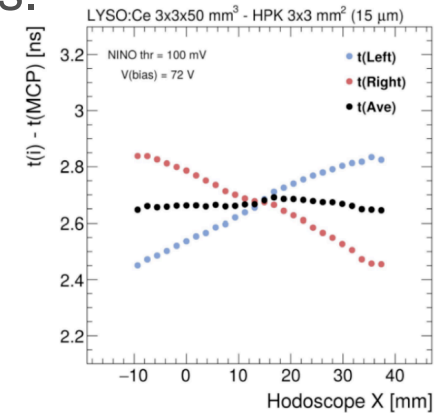
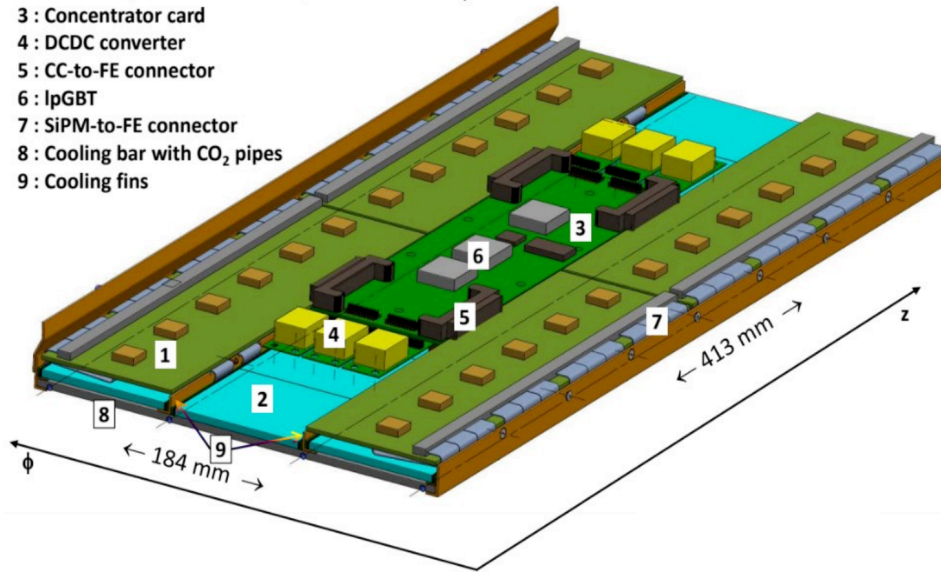

# Endcap Timing Layer (ETL) design

- Low Gain Avalanche Diodes (LGADs) with highly doped p+ region just below the n- implants.
  - Radiation tolerance sufficient for endcap fluence ( $< 2 \times 10^{15} n_{eq}/cm^2$ )
  - Very good timing response and resolution (30-45 ps at the beginning-end of lifetime)
- A total of  $\sim 14 m^2$  detector with two double-sided layers for each endcap
- Small  $1.3 \times 1.3 mm^2$  pixels for low capacitance,  $\sim 8.5M$  channels

## Two disks per endcap

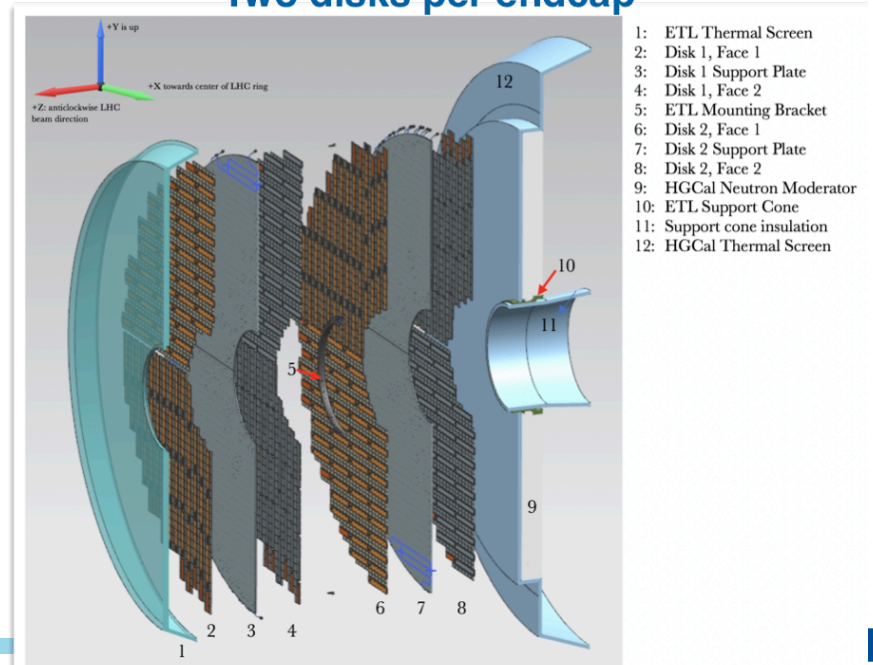
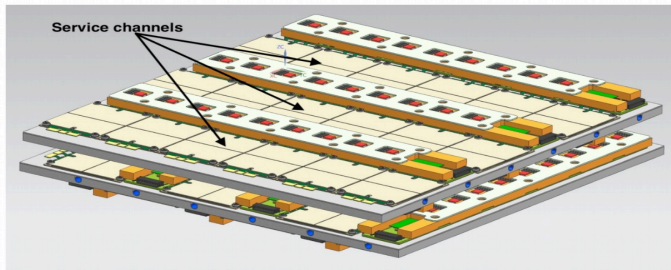
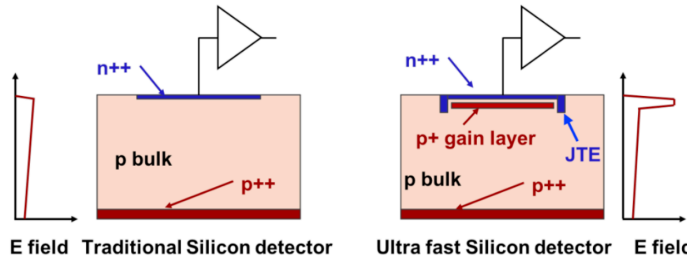

4.5 cm thick!

b

# Endcap Timing Layer (ETL) design

- Sensors are each  $21 \times 42 \text{ mm}^2$  and contain  $16 \times 32$  pixels
- Two ETL ASICs (ETROC) needed to readout one sensor (each ETROC has  $16 \times 16$  channels).
  - Each ETROC consists of pre-amplifier, discriminator and a TDC.
- Excellent efficiency ( $> 99\%$ ) and uniform time resolution in test beams

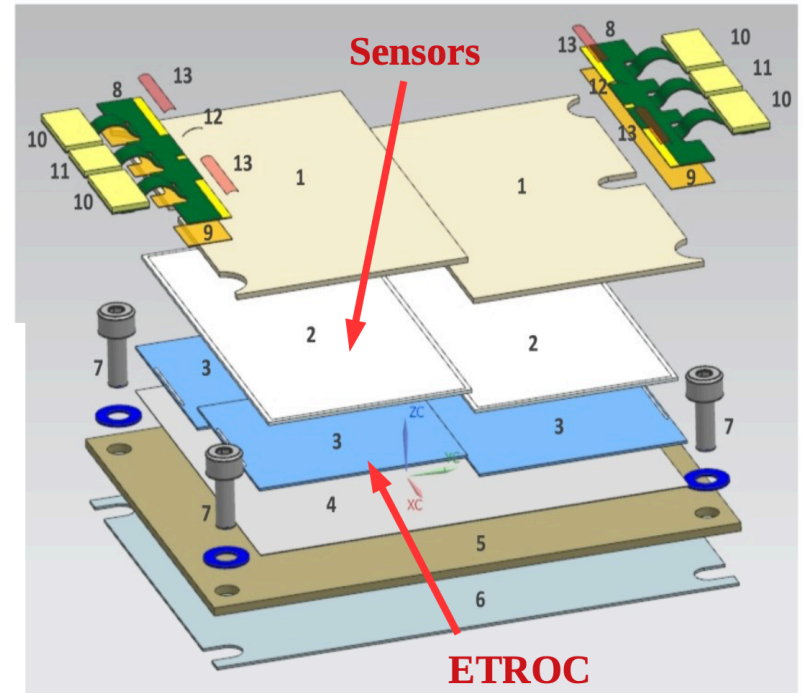
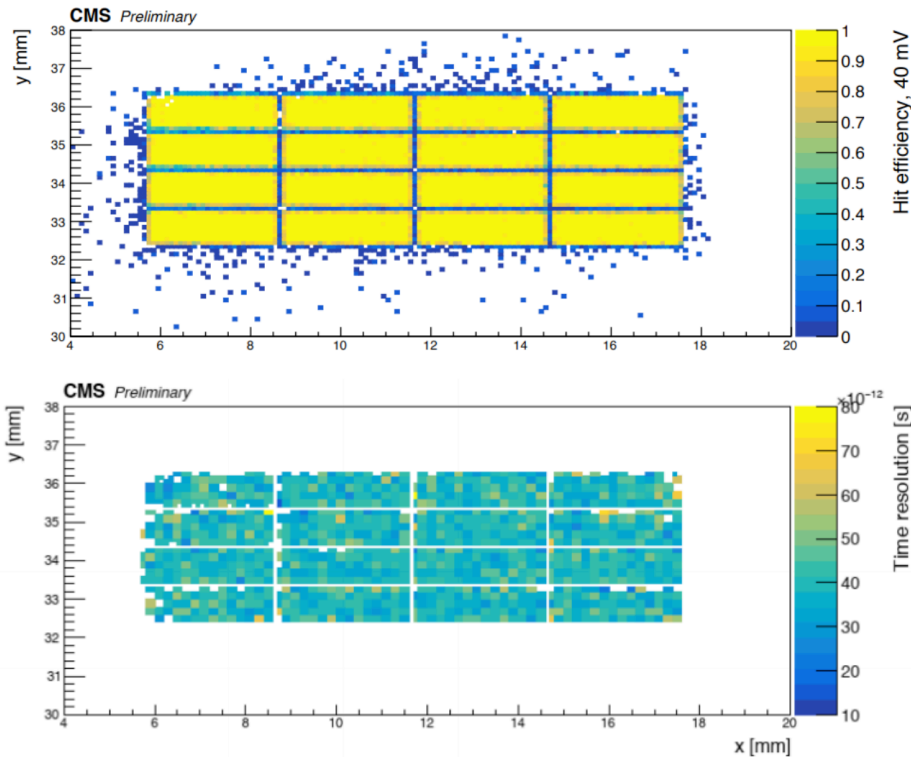

# Event reconstruction at HL-LHC

78 pp collision

HL-LHC bunch crossing  
1 ns interval

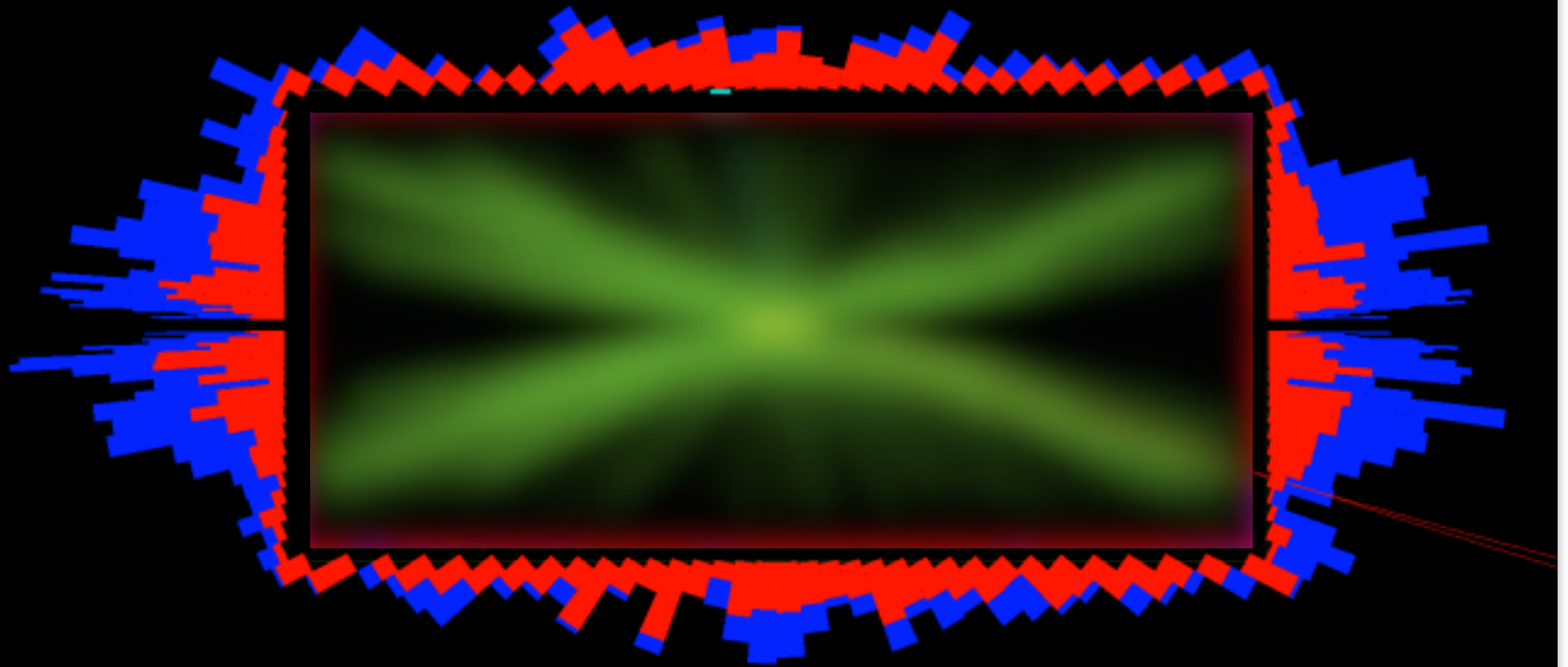

# Event reconstruction at HL-LHC

78 pp collision

HL-LHC bunch crossing  
1 ns interval

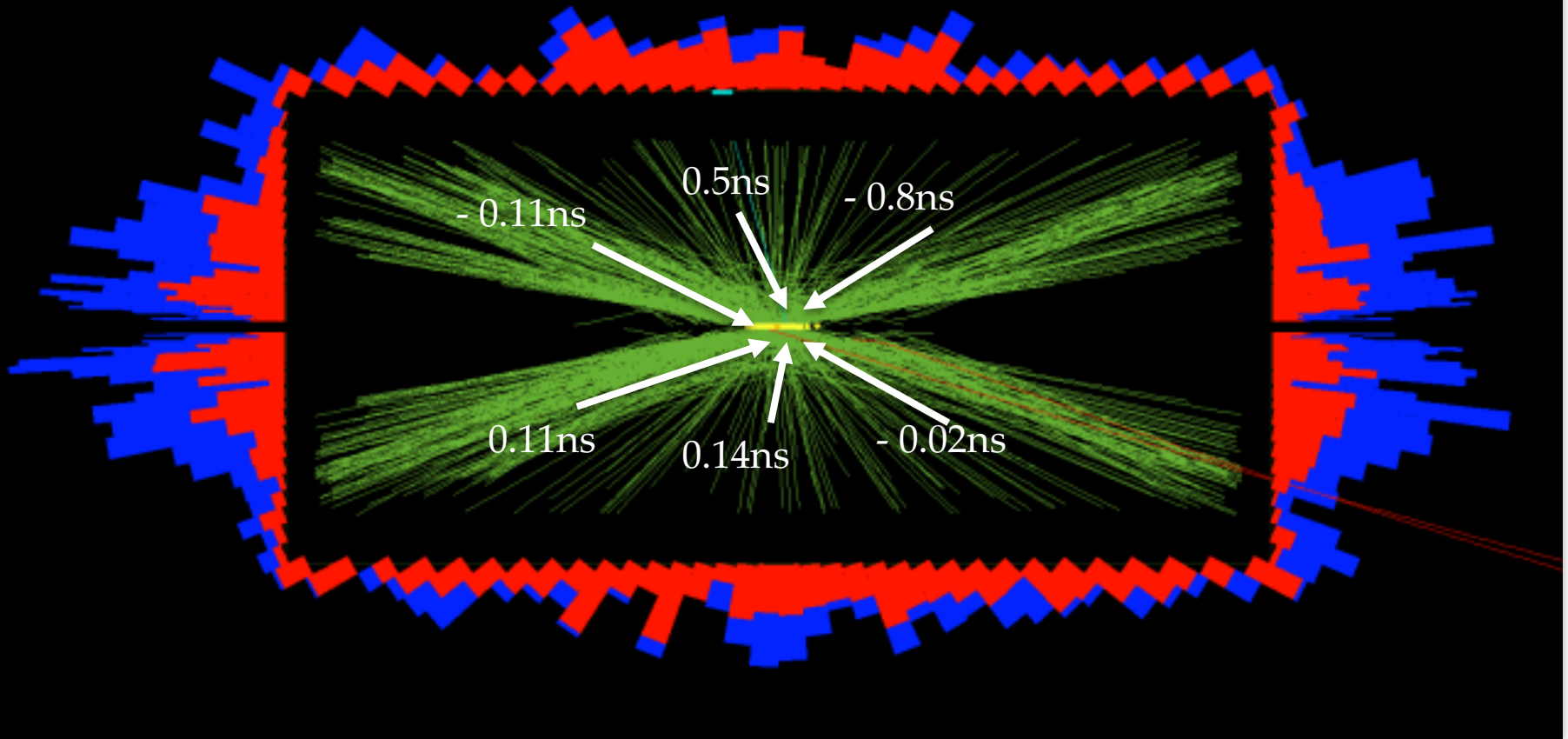

# Precision timing for charged particles

- Traditional **three-dimensional** vertexing can be upgraded to a **four-dimensional** fit
  - Pileup vertices explicitly reconstructed in position **along the beamline** and **time** within the bunch crossing
- Further suppression of charged particles from pileup for jets, MET, lepton isolation, etc...

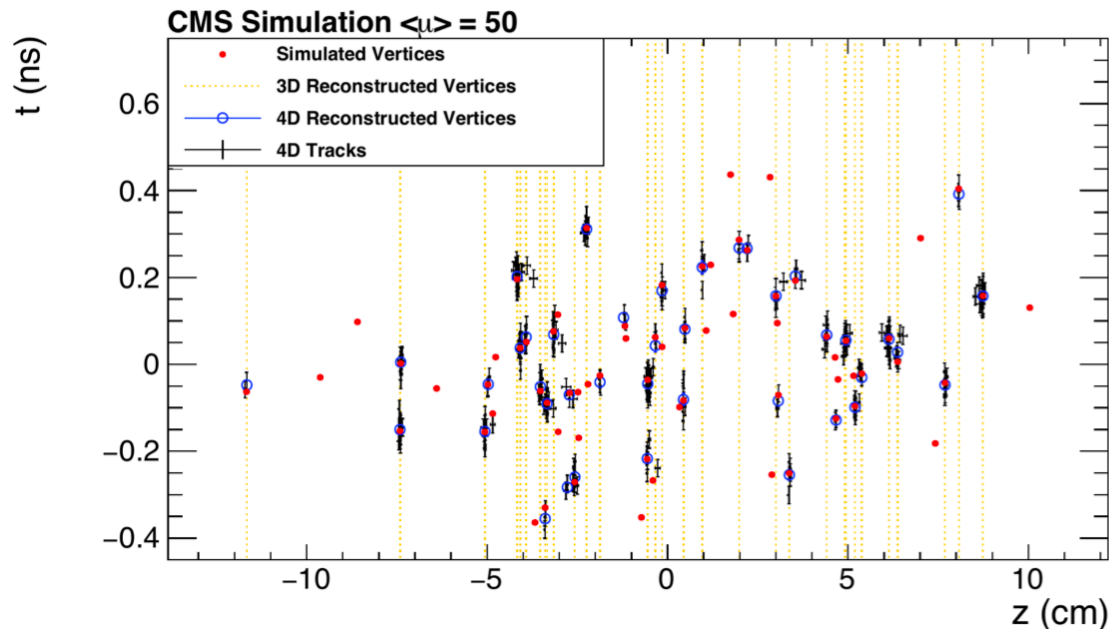

# Precision timing for charged particles

- Traditional **three-dimensional** vertexing can be upgraded to a **four-dimensional** fit
  - Pileup vertices explicitly reconstructed in position **along the beamline** and **time** within the bunch crossing
- Further suppression of charged particles from pileup for jets, MET, lepton isolation, etc...

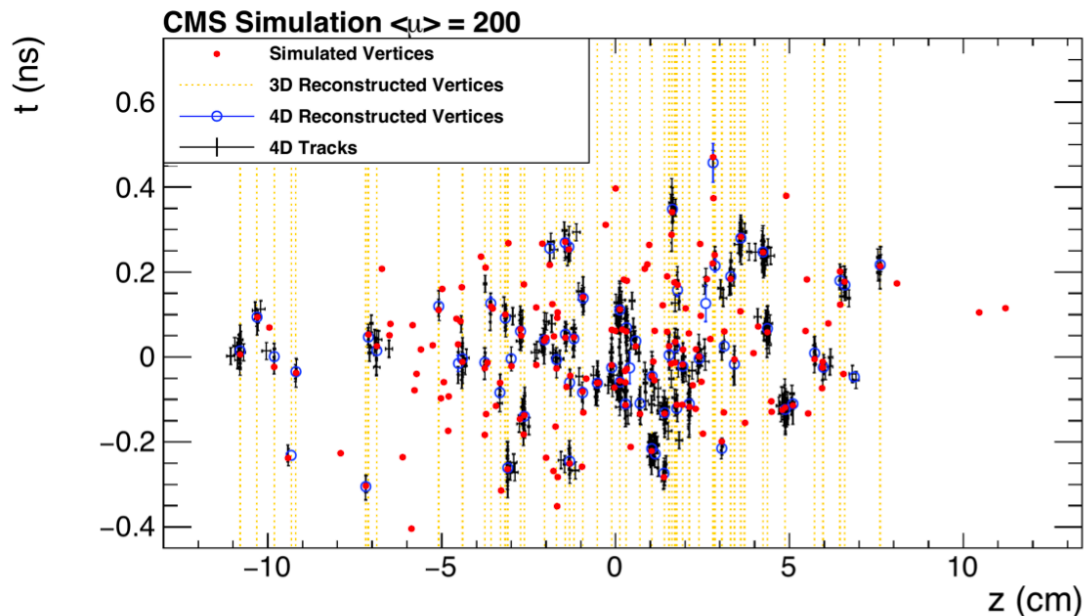

# Pileup rejection

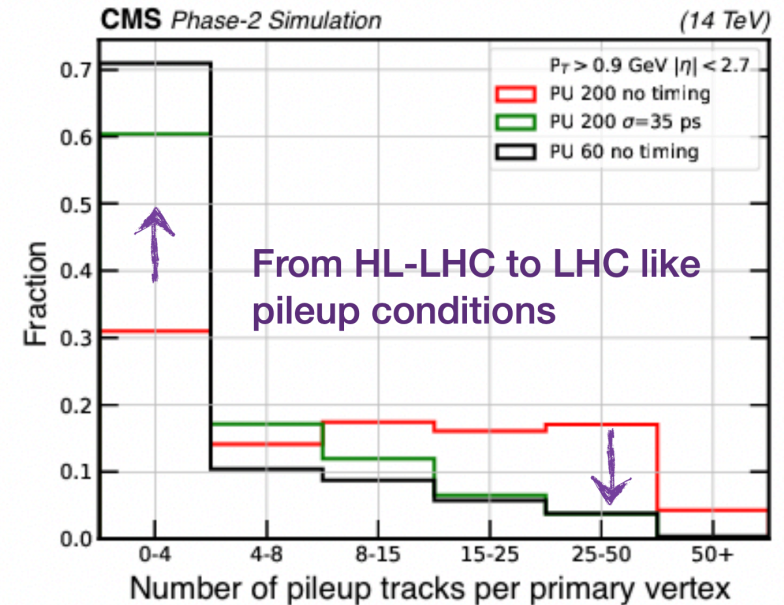
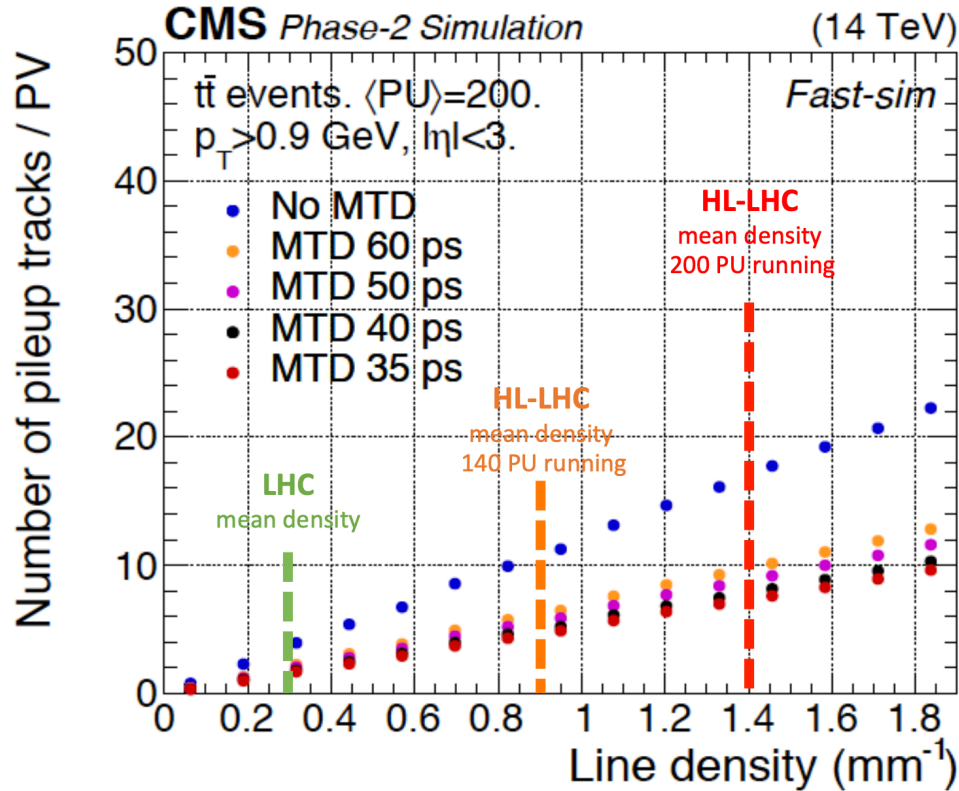

- Time-aware primary vertex reconstruction reduces incorrect association of tracks from nearby pileup interactions by a factor of 2:
  - Fully offsets the impact of the transition from 140  $\rightarrow$  200 PU running
  - Brings per-vertex track purity close to typical current LHC running conditions

# Vertexing

- Iterative 4D vertex reconstruction with TOFPID assignment to handle K/p at low  $p_T$
- Vertex time resolution  $< 10\text{ps}$ , no tails from slow hadrons
- Vertex merging rate @PU200 reduced from 15% to 1% from 3D to 4D vertex

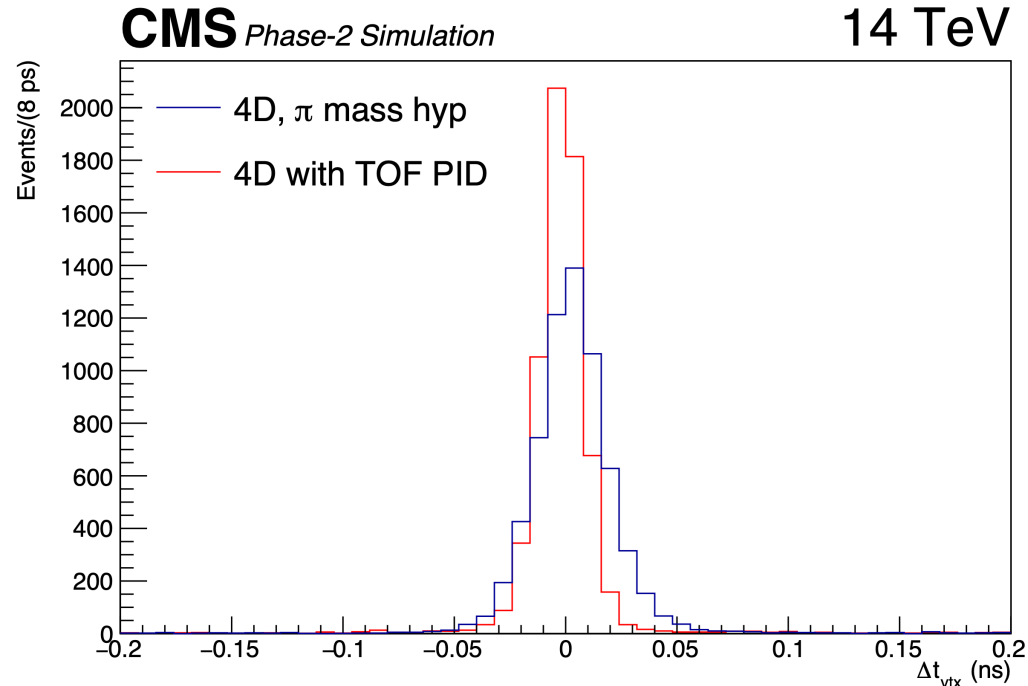

# Time-of-flight Particle ID

- Time-of-flight particle identification:  $2\sigma$   $\pi/K$  separation up to  $p \sim 2$  GeV and  $K/p$  up to  $p \sim 4$  GeV
  - New handle for CMS for heavy flavor physics

$$\frac{1}{\beta} = \frac{c(t_0^{\text{MTD}} - t_0^{\text{evt}})}{L}$$

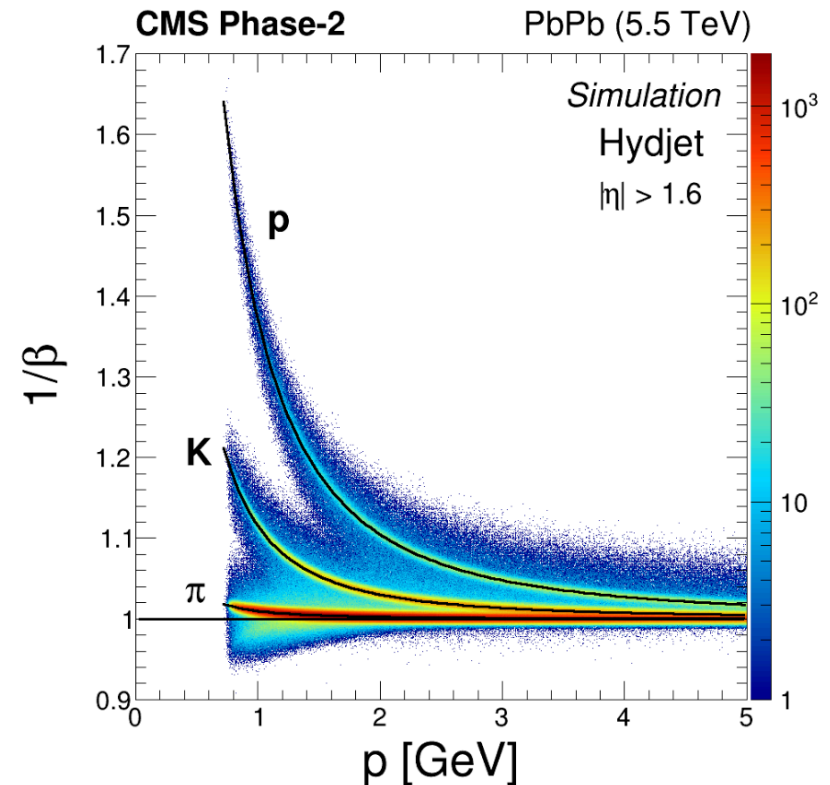
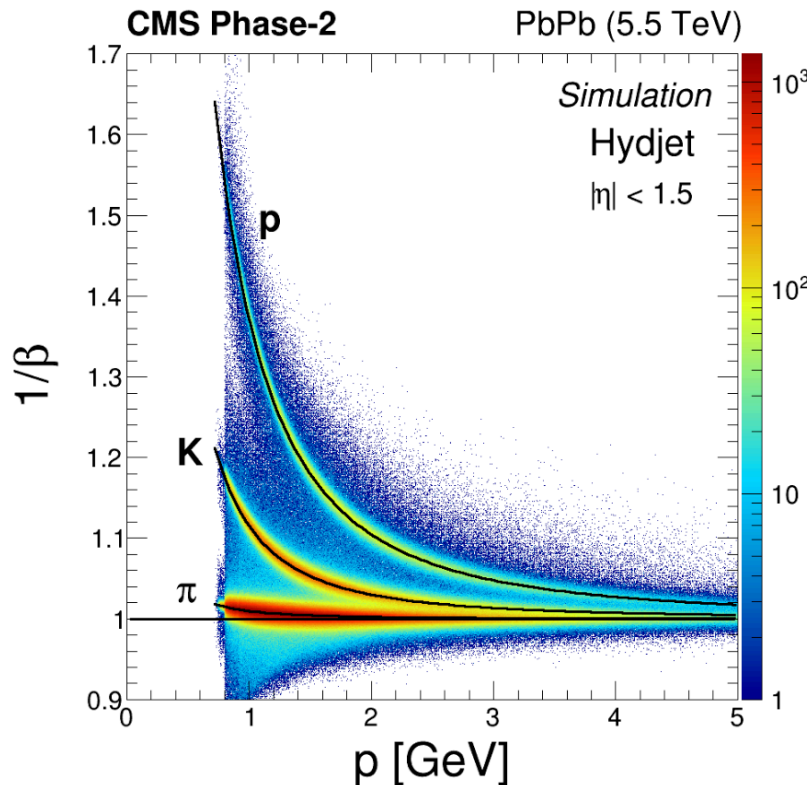

# Lepton isolation

- Gain is combined for multiple leptons in final states, e.g.  $H \rightarrow ZZ \rightarrow 4l$ 
  - Higher gains in forward region, higher line densities – tighter isolation
- Relative gain on efficiency improves at lower  $p_T$ , up to 20-25% going at  $p_T$  around 10-20 GeV
  - Critical to maintain low  $p_T$  thresholds for multi-leptons final states:  $H \rightarrow 4l$ : lowest  $p_T$  cut  $>5$  GeV
  - b-physics analyses ( $B(d,s) \rightarrow \mu\mu$ ,  $B \rightarrow K^* \mu\mu$ , ...)
- Higher gains (10-15%) for  $\tau$  (looser  $dz$  cuts, tighter isolation).  $\tau$  ID not yet fully optimized for Phase-2 reconstruction

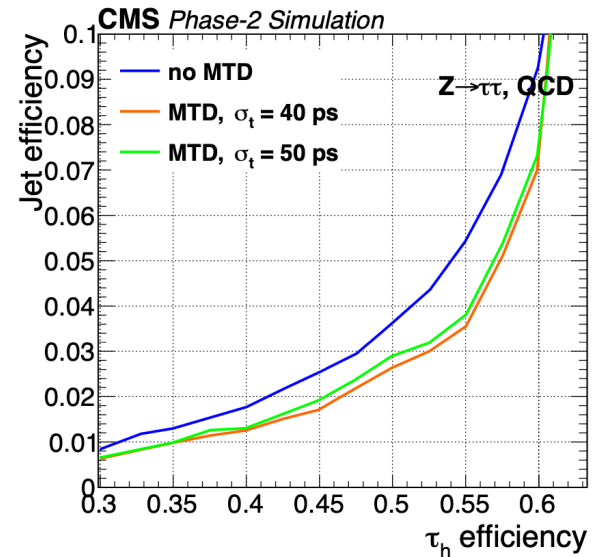
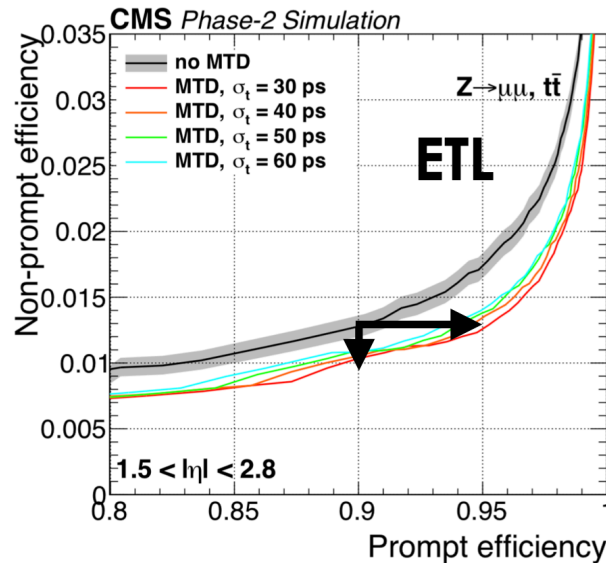
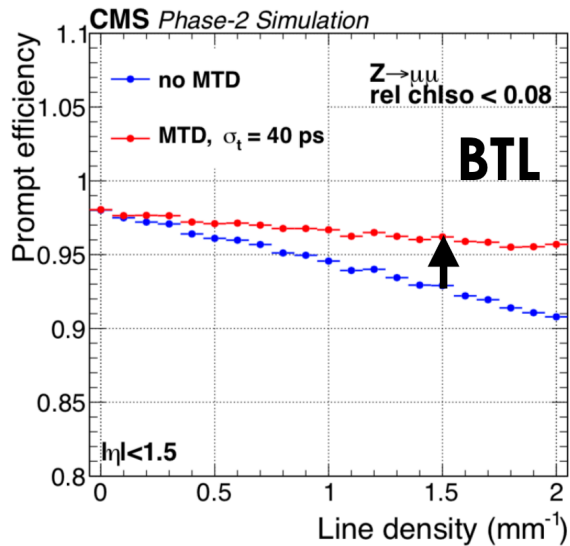

# B-tagging

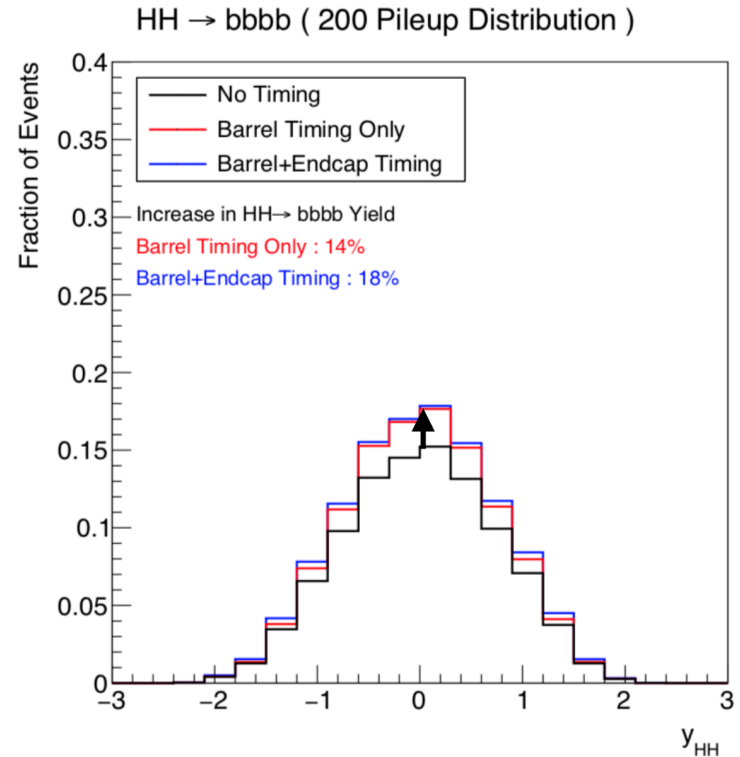
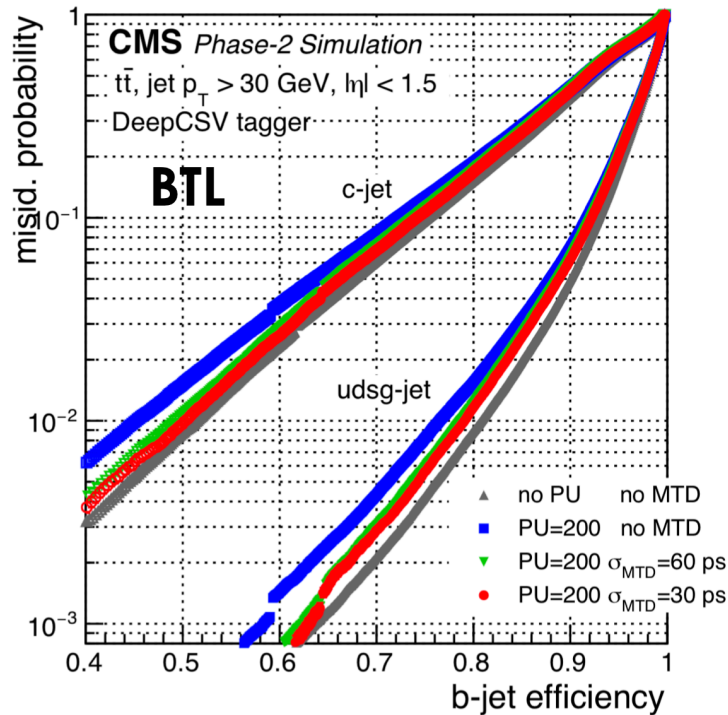

- Efficiency improvements for b-tagging: 3%(BTL) 6%(ETL)
  - b-tagging not yet fully optimized for Phase-2
  - timing used only for track selection
- Significant acceptance gains in a critical HL-LHC final states with several b:  $HH \rightarrow bbbb$

# Jets and Missing Transverse Energy

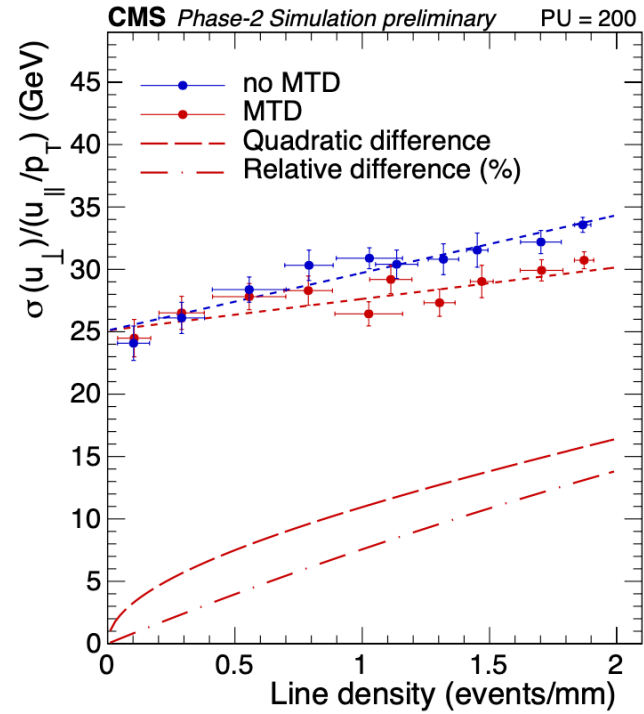
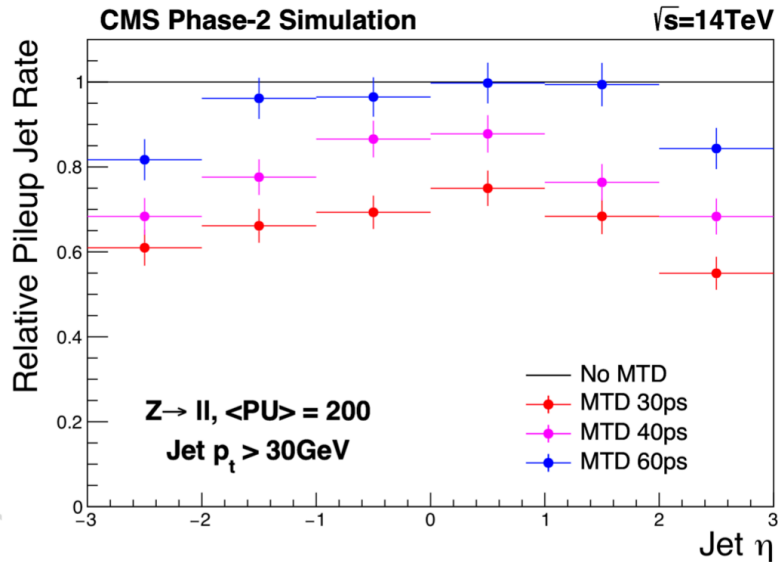

- Up to 40% PU jets reduction especially in forward region
  - Z+jets background reduced by 20-30% for  $p_T$  cuts at 20-30 GeV
- 12% relative gain for MET resolution from charged PU mitigation
  - 40% in background reduction if requiring large MET e.g.  $>150$  GeV

# Physics impact: Higgs physics

- Significant impact on HL-LHC Higgs program
  - 26% increase in effective luminosity for  $H \rightarrow ZZ \rightarrow 4\ell$
  - 22% increase in effective luminosity for  $H \rightarrow ZZ \rightarrow b\bar{b}\gamma\gamma$
  - 25% increase in effective luminosity for VBF  $H \rightarrow \tau\tau$
- Further improvements:
  - resolution improvements (e.g.  $m_{\tau\tau}$ ); run at higher instantaneous luminosity

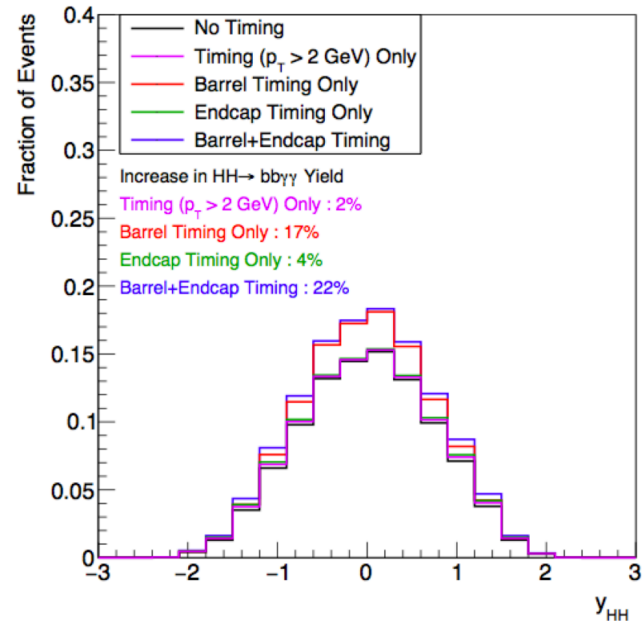
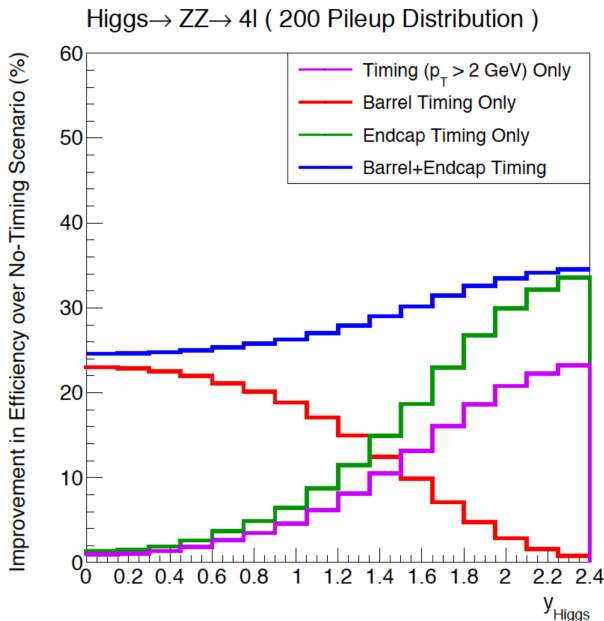

# Physics impact: long-lived particles

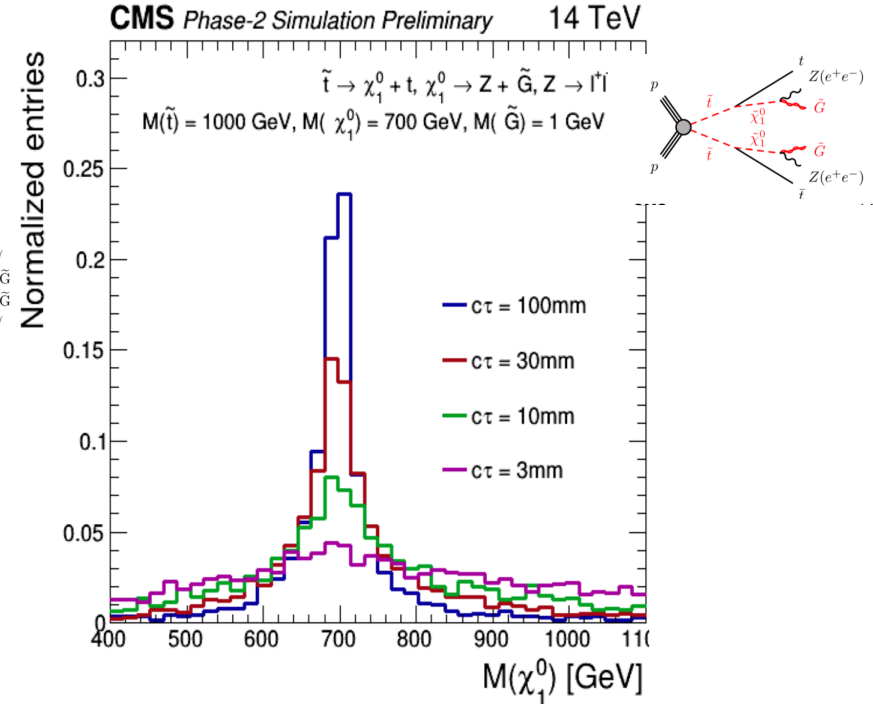
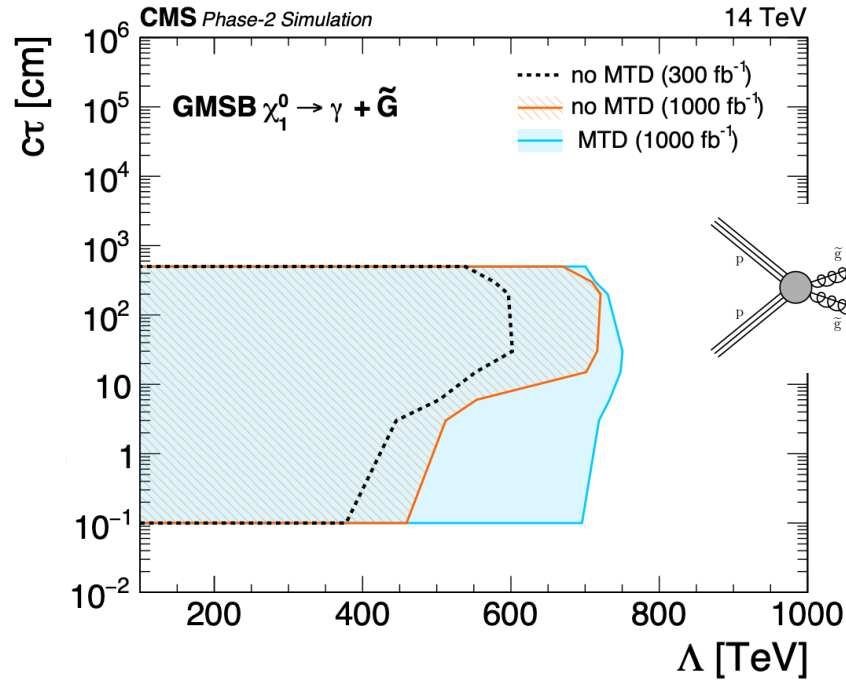

- Vertex timing enhances Long-lived particle physics program
- In topologies involving secondary vertices, MTD provides a unique handle to reconstruct the mass of the long-lived neutral particles (e.g.  $\chi_0$ )

# Physics impact: long-lived particles

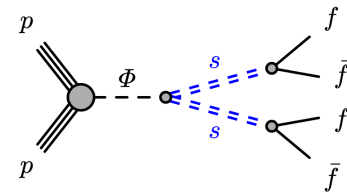

study by Zhen Liu et al.

<https://arxiv.org/abs/1805.05957>

Precision Timing Enhanced Search Limit (HL-LHC)

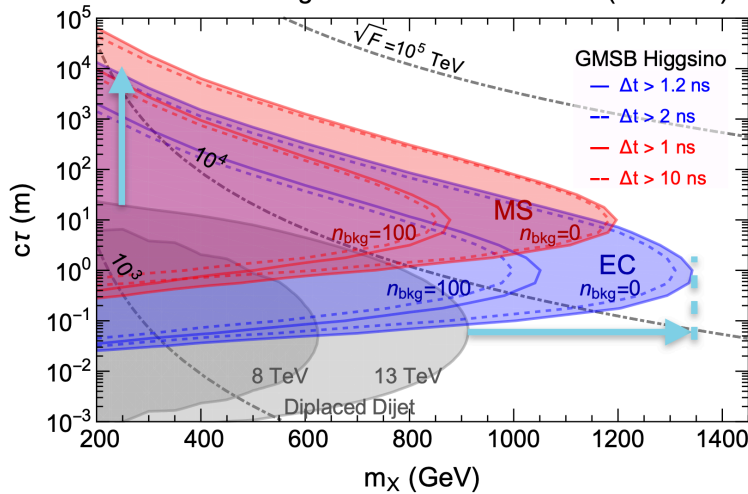

$$\Delta t = \frac{l_X}{\beta_X} + \frac{l_a}{\beta_a} - \frac{l_{SM}}{\beta_{SM}}$$

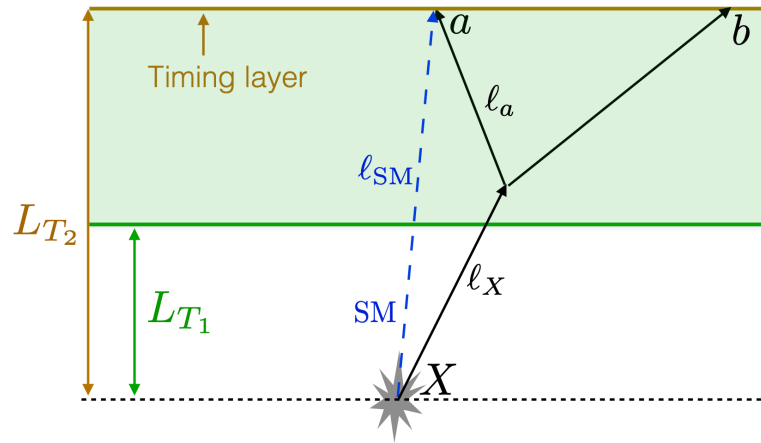

- Timing results in large gains in  $c\tau$  and mass reach
- L1-trigger to fully exploit LLP potential
  - MTD and ECAL timing trigger for LLP searches can reach 40% signal efficiency

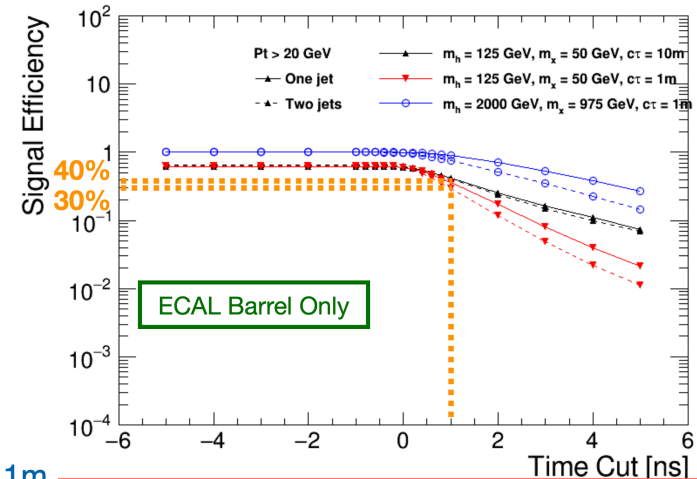

$M_h = 125 \text{ GeV}$   
 $M_\chi = 50 \text{ GeV}, c\tau = 1 \text{ m}$



# Physics impact: TOF Particle ID

- Competitive momentum coverage comparable to ALICE and STAR

- Significantly suppressed background candidates
- Signal significance is drastically improved
- The region of  $|\eta| > 1$  is uncovered by other experiments

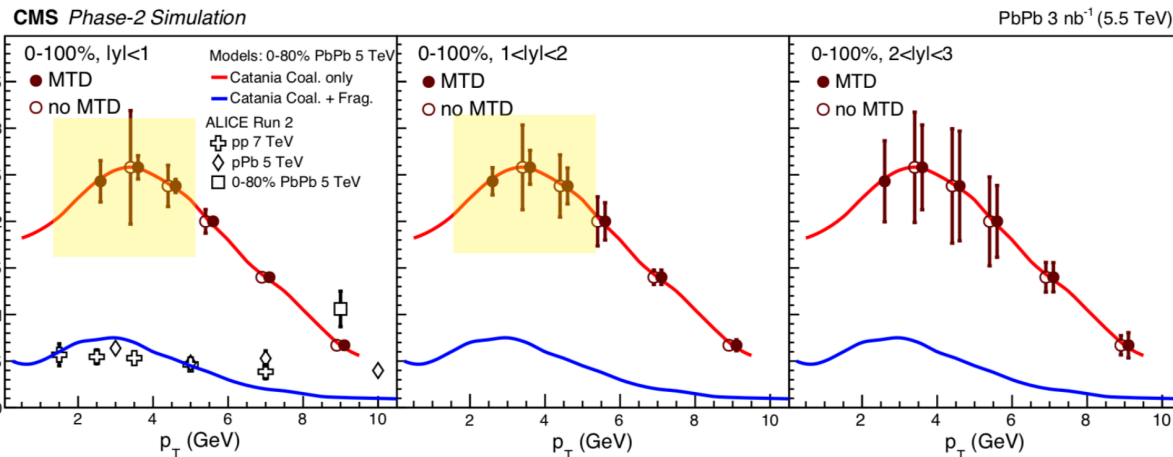
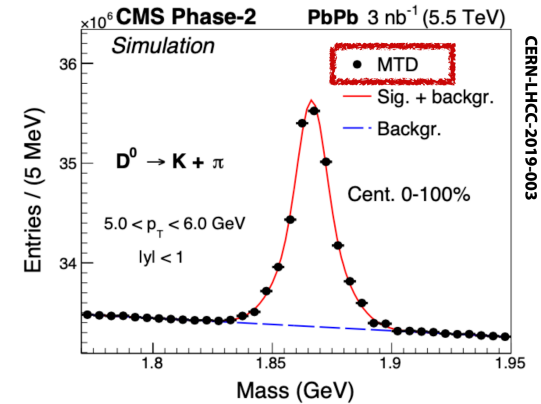
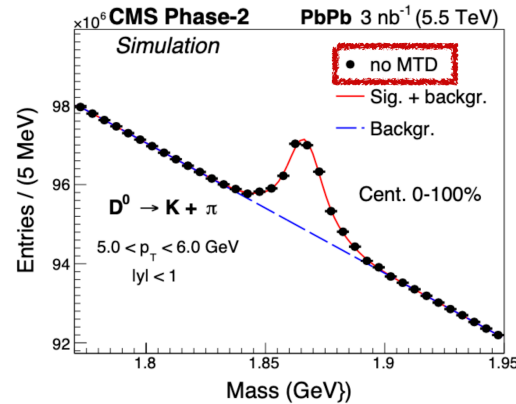

- Unique possibility to study charm and bottom hadrons production over a wide range of  $p_T$  and rapidity.
- Low  $p_T$  regions (inaccessible without MTD) should have the largest effect from QGP.

# Summary

- Timing is an enabling technology change for future experiments, HL-LHC, FCC, neutrino physics, and beyond
  - Timing precision of 30-40 ps achieved with several Si-based technologies
  - Precision timing for Calorimeters and MIP tracking achievable
- New technologies and applications being actively developed
  - The last dimension to be used in precision experiments!
  - Improvements in event reconstruction, and new handles in searches for deviations from the Standard Model
  - Future tracking detectors will likely be required to have significant timing precision