

Seminar

u^b

b
UNIVERSITÄT
BERN

AEC
ALBERT EINSTEIN CENTER
FOR FUNDAMENTAL PHYSICS

Construction and operation of the Bern “EXO-100” cryogenic facility for R&D in liquid xenon: advances in barium ion tagging

Sébastien Delaquis
University of Bern
Switzerland



Outline

Double-beta decay ($\beta\beta$)

- *a way to address some of the open questions in the neutrino sector*

The Enriched Xenon Observatory (EXO)

- *EXO's approach to address the challenge*
- *the concept of barium ion tagging – open R&D questions*

Advances in barium ion tagging:

- Analysis of alpha decays with EXO-200 data
 - *ion properties relevant for ion tagging in liquid xenon*
- The EXO-100 facility
 - *construction and operation of a cryogenic R&D facility*



Neutrino physics: status quo

Measured with neutrino oscillation experiments:

3 mixing angles
2 Δm^2

Open questions in the neutrino sector:

- Mass hierarchy
- Absolute neutrino masses
- Nature of neutrino mass (Dirac, Majorana)
- CP violation in the lepton sector
- Massive sterile neutrinos

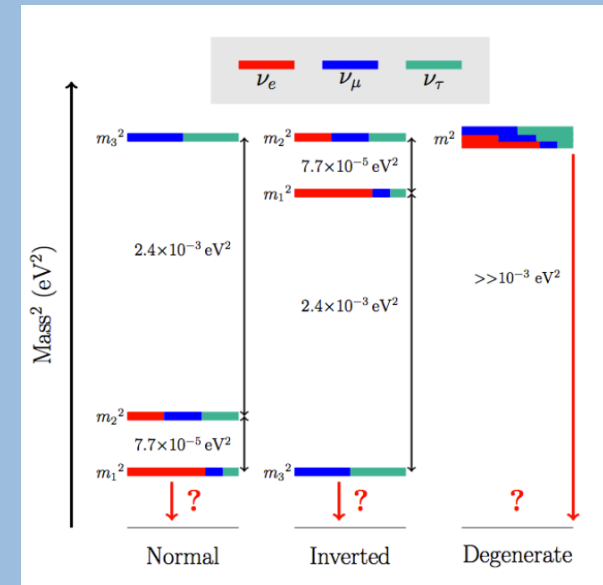

Double-beta decay: determining the absolute neutrino mass

Search for neutrinoless double-beta decay

➤ sensitive to Majorana neutrinos

$$\langle m_{\beta\beta} \rangle^2 = \left| \sum_i U_{ei}^2 m_i \right|^2 = \left| \sum_i |U_{ei}|^2 e^{i\alpha_i} m_i \right|^2$$

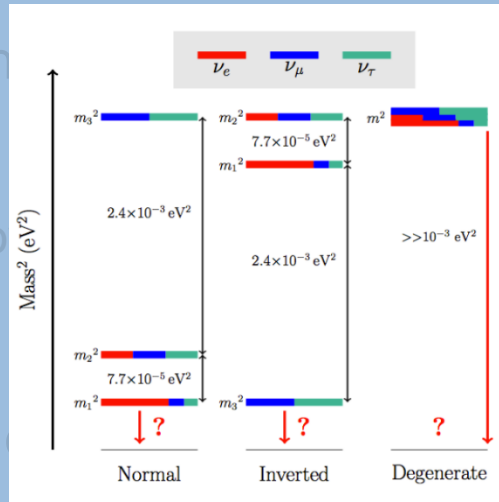
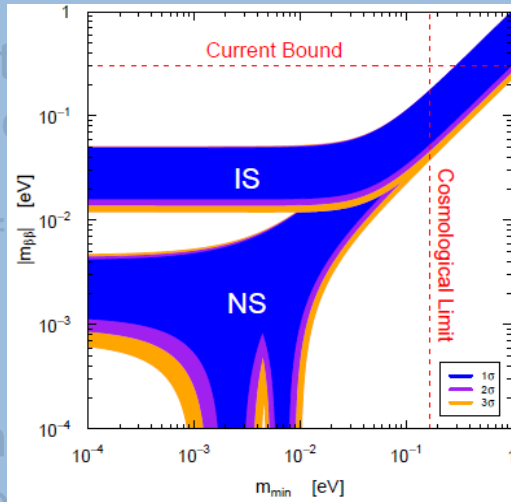

$$\langle m_{\beta\beta} \rangle^2 = \sum_i |U_{ei}|^2 m_{\nu_i}^2$$

$$M = \sum_i m_{\nu_i}$$

Double-beta decay: decay modes

Two neutrino double-beta decay ($2\nu\beta\beta$)

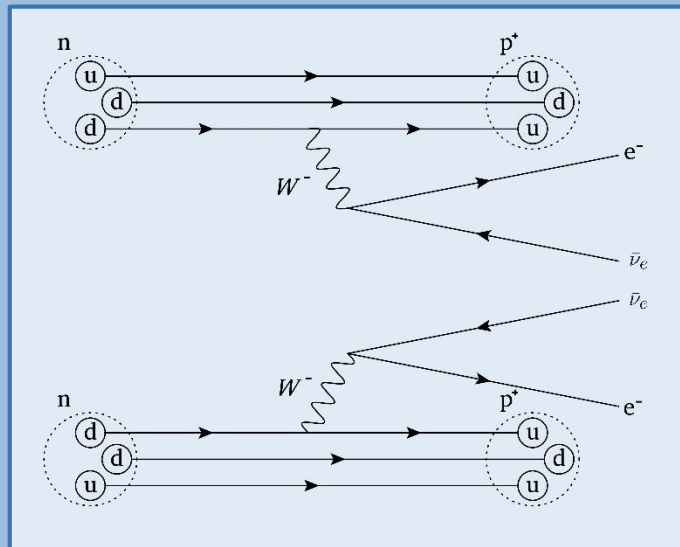

$$2\nu\beta\beta: 2n^0 \rightarrow 2p^+ + 2e^- + 2\bar{\nu}_e$$

- Allowed by the SM of particle physics
- Observed in 11 isotopes so far:

$${}_{54}^{136}\text{Xe}: T_{1/2}^{2\nu\beta\beta} = (2.165 \pm 0.016(\text{stat}) \pm 0.059(\text{sys})) 10^{21} \text{ yr}$$

EXO Collaboration: Phys. Rev. C 89, 015502 (2014)

As a comparison the age of the universe: $(13.798 \pm 0.037) 10^9 \text{ yr}$

This is the most precisely measured half-life of any $2\nu\beta\beta$ decay to date.

Moreover, this is the slowest process ever directly observed by mankind!

Double-beta decay: decay modes

Neutrinoless double-beta decay ($0\nu\beta\beta$)

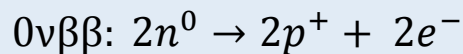
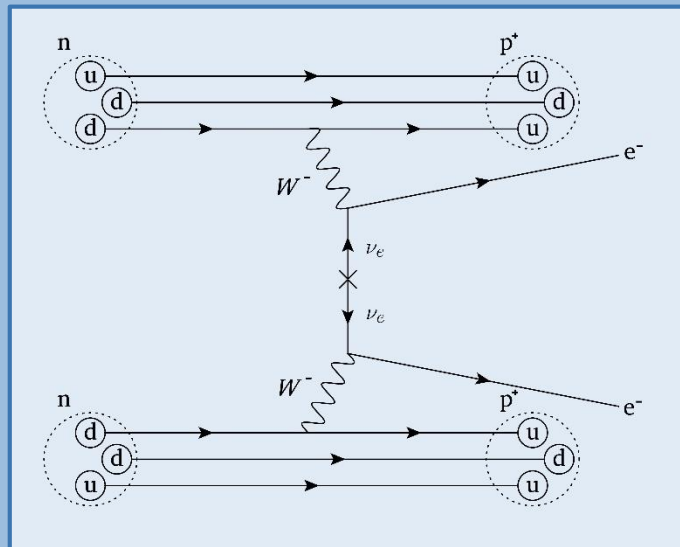

- Only allowed if the neutrino is a Majorana particle!
- Violating total lepton number: $\Delta L = 2$
- **Hypothetical process:** not observed so far (one controversial claim).

$$\frac{1}{T_{1/2}^{0\nu}} = G^{0\nu} |M^{0\nu}|^2 |\langle m_{\beta\beta} \rangle|^2$$

$G^{0\nu}$ phase space factor
 $M^{0\nu}$ nuclear matrix element
 $\langle m_{\beta\beta} \rangle$ effective neutrino mass

Double-beta decay: decay modes

Seperating $0\nu\beta\beta$ from $2\nu\beta\beta$

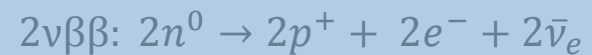
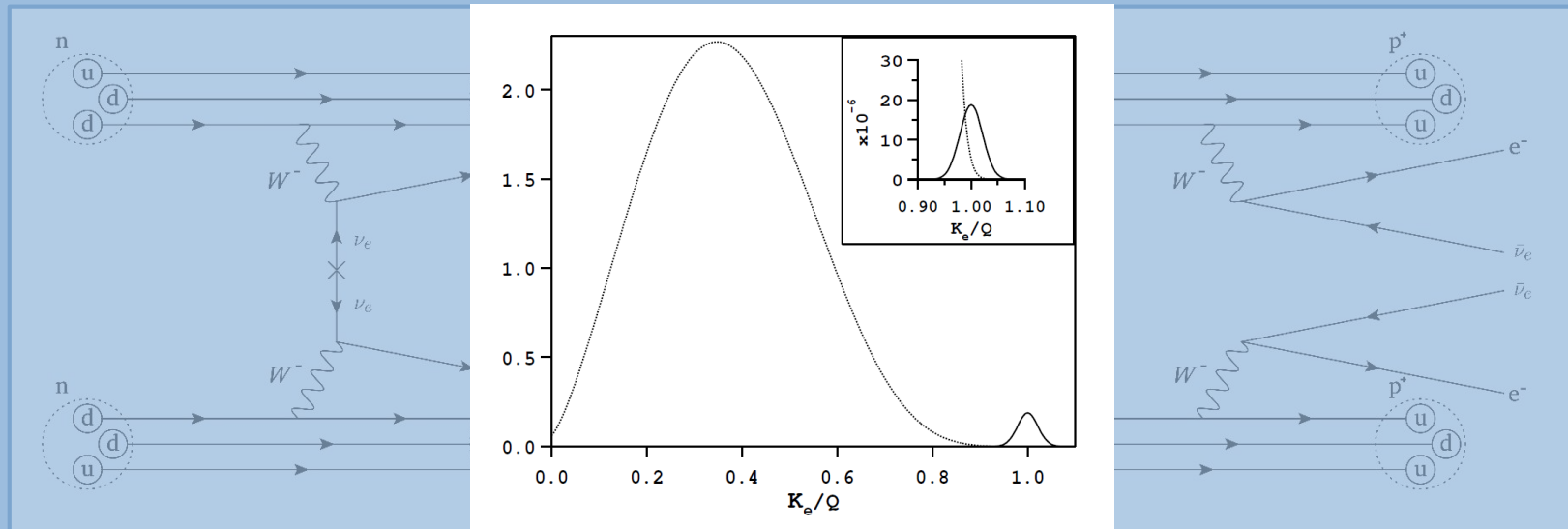

Energy resolution is essential!

Double-beta decay: candidate isotopes

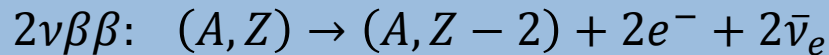
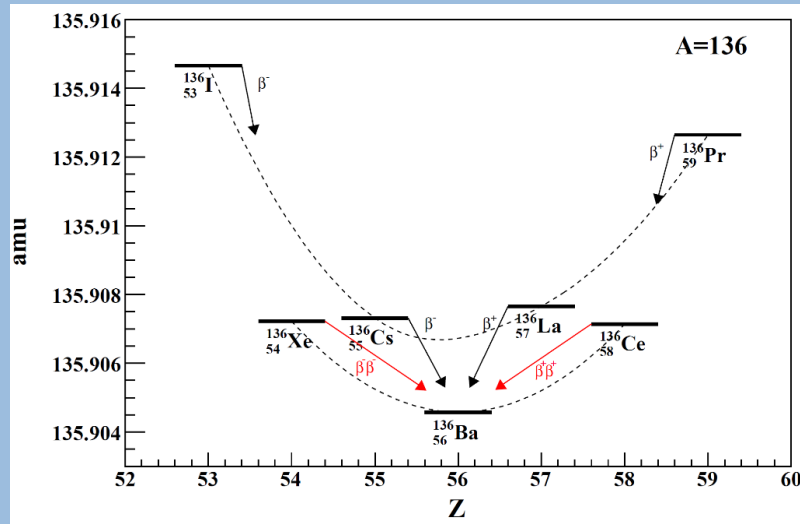

Realistically observable only in a few even-even nuclei (35 naturally occurring isotopes).

Q-value

- Sargent's rule: decay rate $\propto Q^5$
- backgrounds

Natural abundance of the isotope and ease of enrichment

A suited detection technique

- source as detection medium
- easy to purify (nat. rad.)

Double-beta decay: detection technique

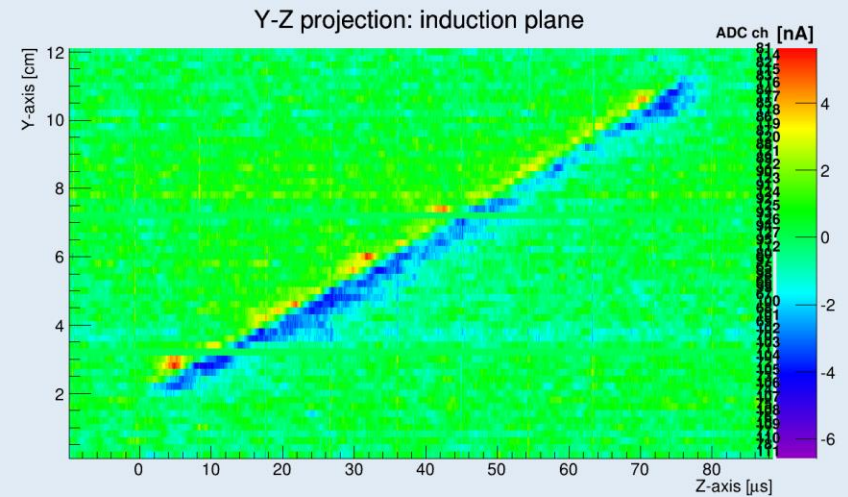
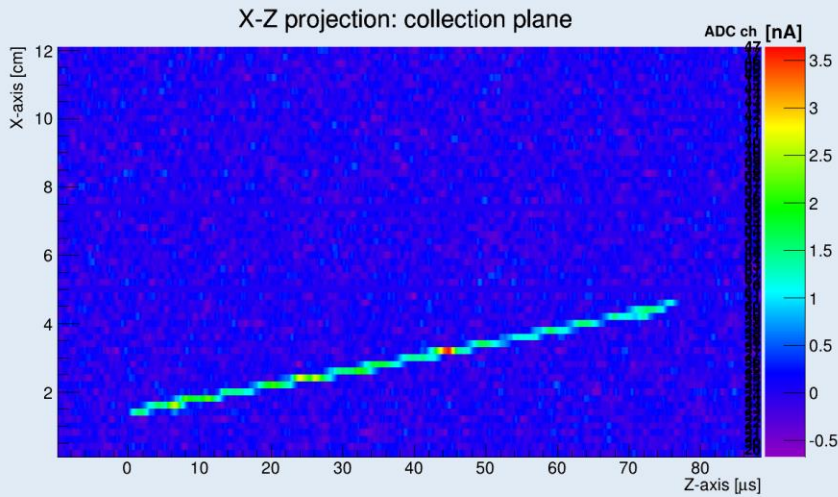

PMT signals vs. Z-axis

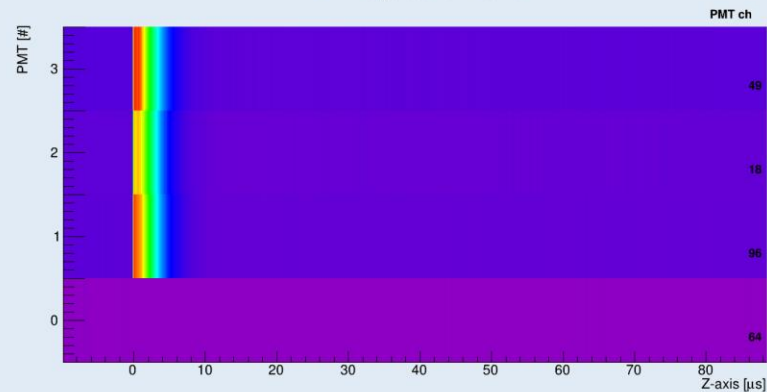

Double-beta decay: $\beta\beta$ experiments

^{76}Ge :
GERDA

^{130}Te :
CUORE

^{136}Xe :
EXO
KamLand-Zen

Others:
NEMO

Advantage of xenon TPC:

- segmentation

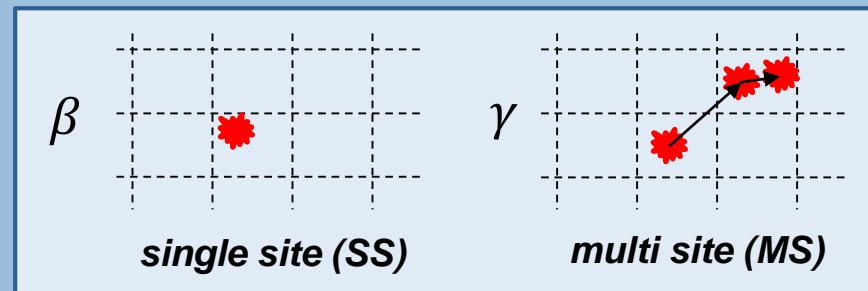

- good energy resolution
- unique capability to identify the decay product;
barium tagging

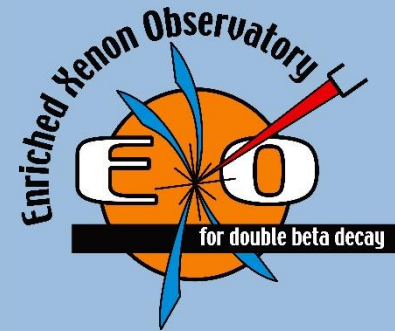

Multi stage project:

- EXO-200
- nEXO
- nEXO with barium tagging

The Enriched Xenon Observatory: EXO-200 set-up

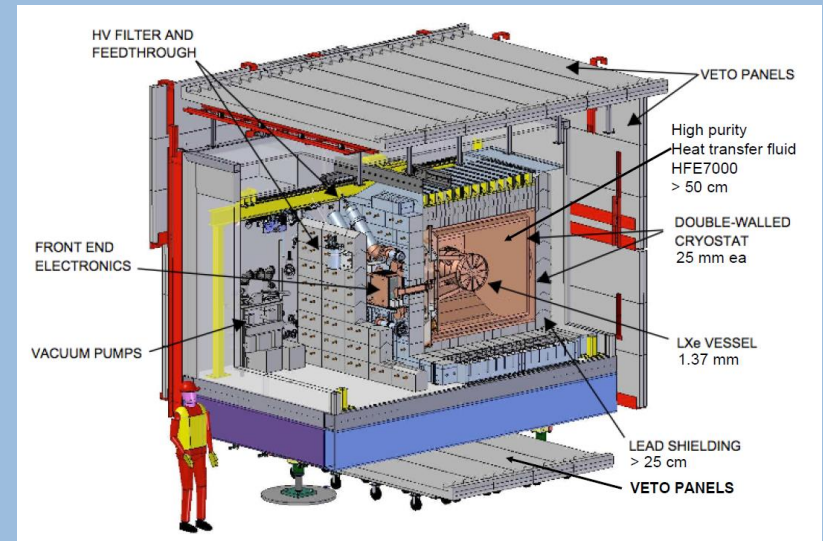
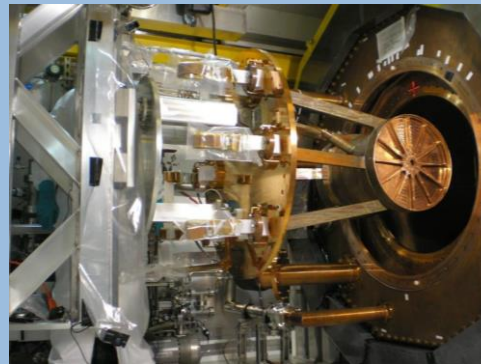
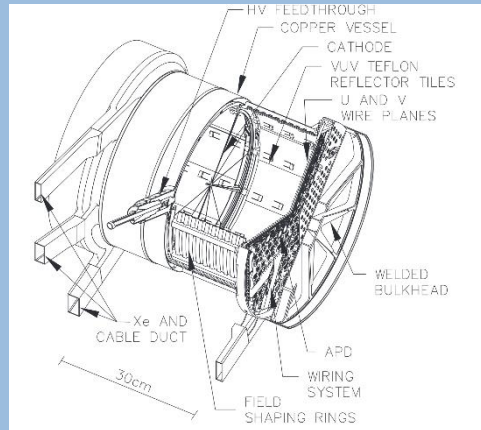
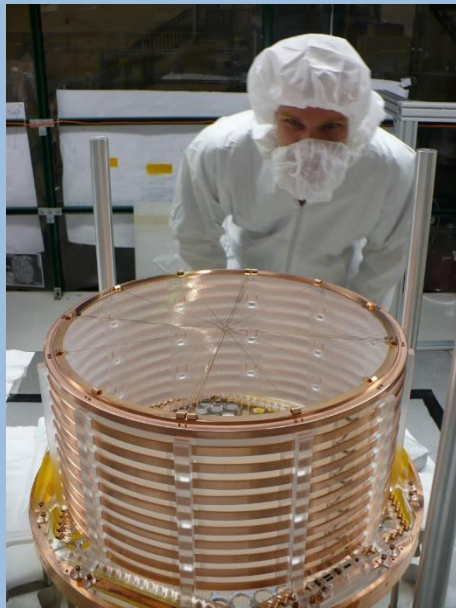

Located at WIPP in New Mexico, 655 m.w.e below ground

The Enriched Xenon Observatory: EXO-200 results

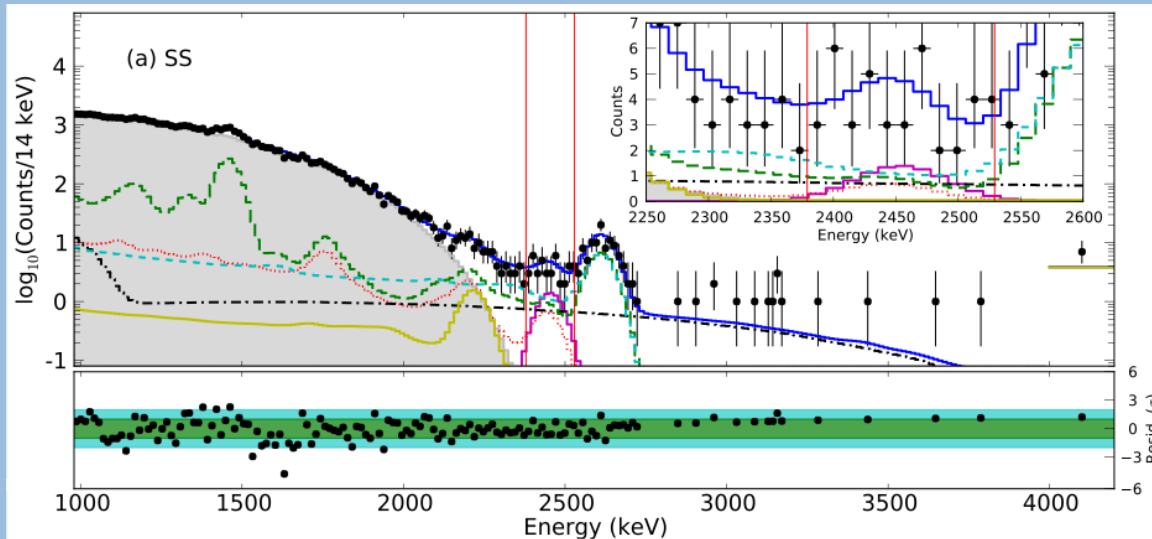

Expected background

***Th-232 chain:* 16.0**

***U-238 chain:* 8.1**

***Xe-137:* 7.0**

Total expected: **31.1 ± 3.8**

Total observed: **39**

Best fit for $0\nu\beta\beta$: **9.9**

$$T_{1/2}^{2\nu\beta\beta} = (2.165 \pm 0.016(stat) \pm 0.059(sys)) 10^{21} \text{ yr}$$

EXO Collaboration: Phys. Rev. C 89, 015502 (2014)

$$T_{1/2}^{0\nu\beta\beta} > 1.1 10^{25} \text{ yr at 90\% C. L.}$$

EXO Collaboration: Nature (London) 510, 299-234 (2014)

The Enriched Xenon Observatory: EXO-200 performance

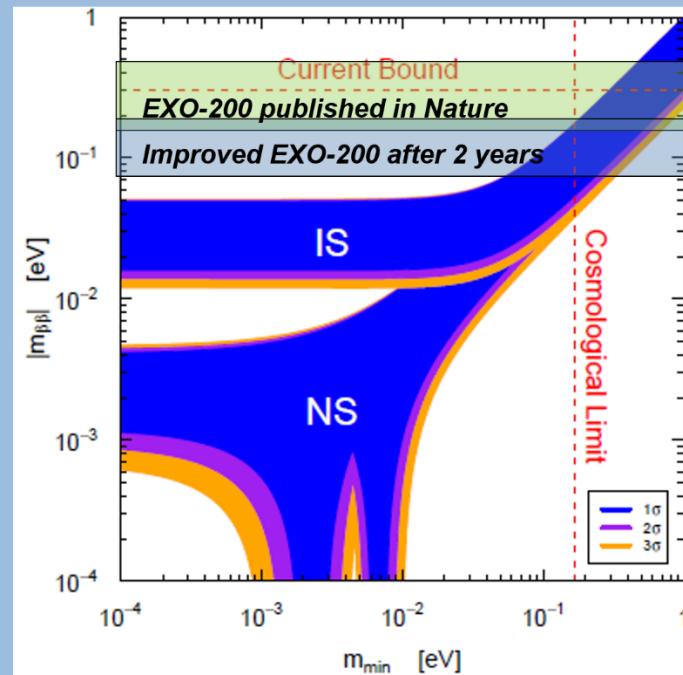

The Enriched Xenon Observatory: nEXO

A single TPC

5 tn of enriched xenon

Operational in ~2020

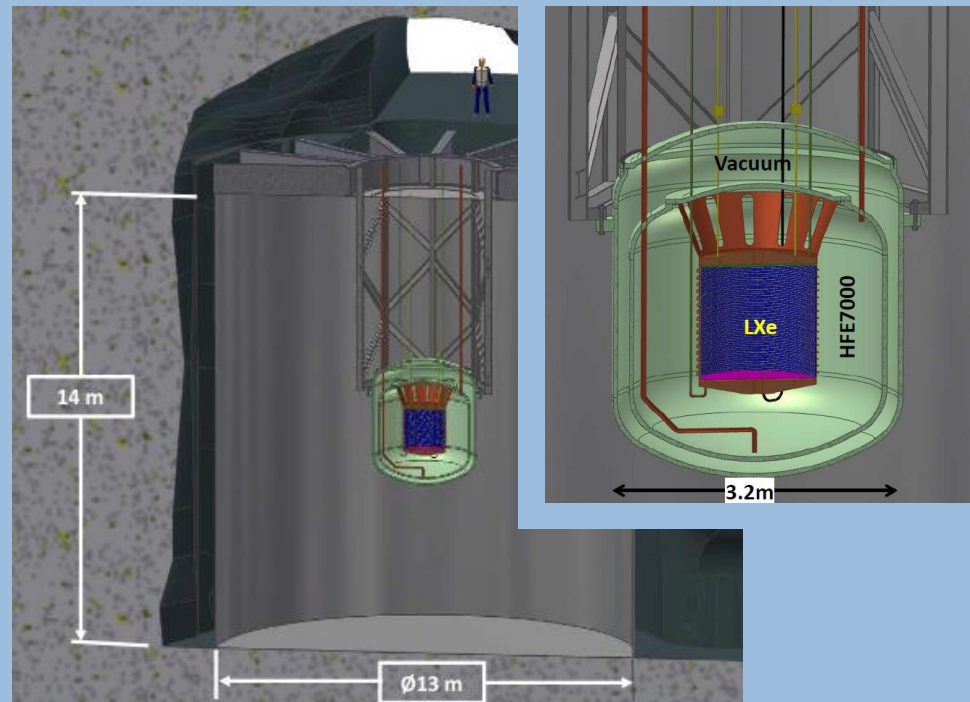

The Enriched Xenon Observatory: nEXO expected performance

How can we further increase sensitivity?

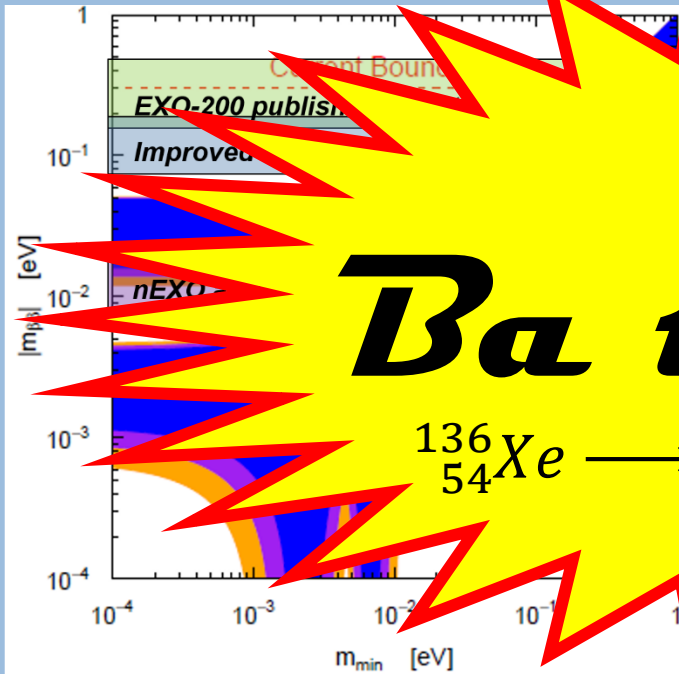

Ba tagging



trim. 90keV or the Q-value

The Enriched Xenon Observatory: expected performance of nEXO w. Ba tagging

Advantage of barium tagging:

- tag all backgrounds not related to $\beta\beta$
- ultimate background $2\nu\beta\beta$

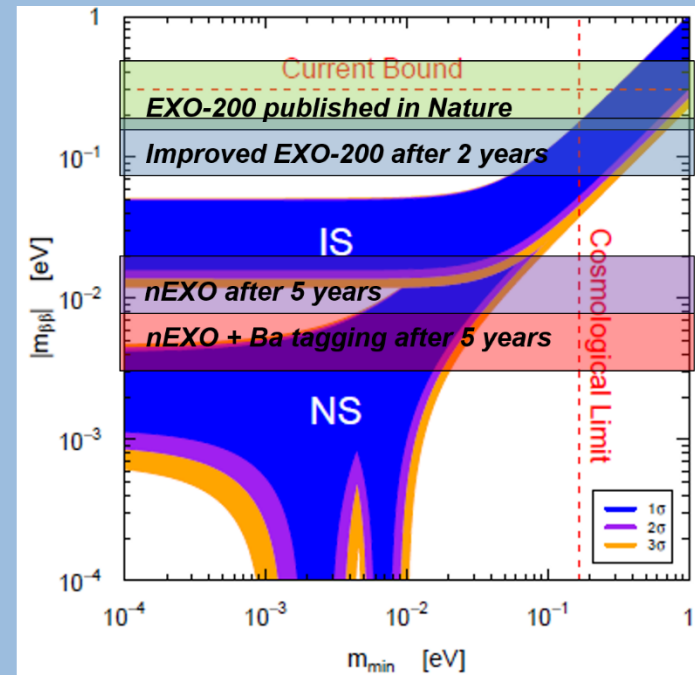

The Enriched Xenon Observatory: barium tagging technique

Ba⁺ grabber probe



cavity ionizer

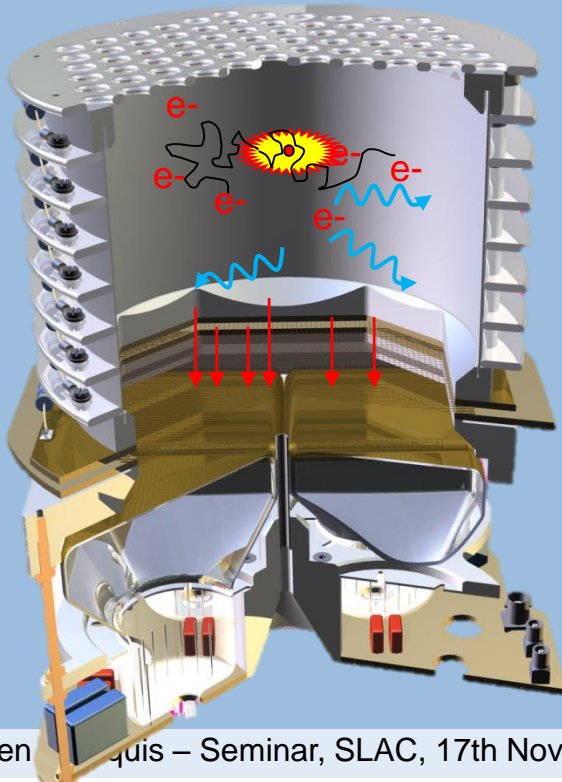

ion trap

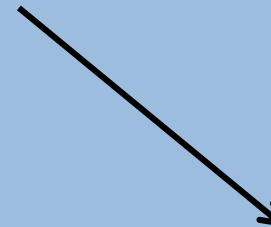

mass filter

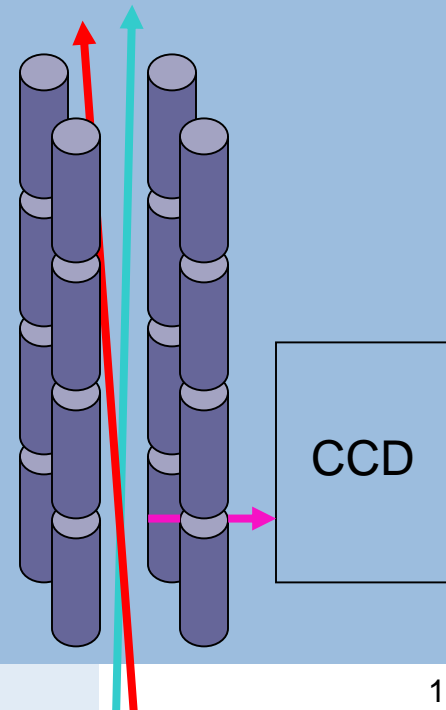

The Enriched Xenon Observatory: barium tagging technique

Ba⁺ grabber probe



cavity ionizer

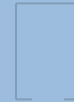

mass filter

ion trap

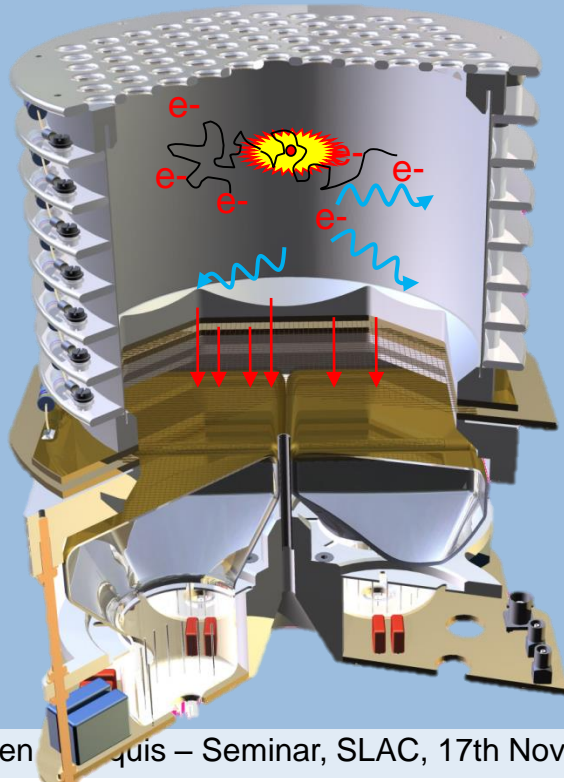
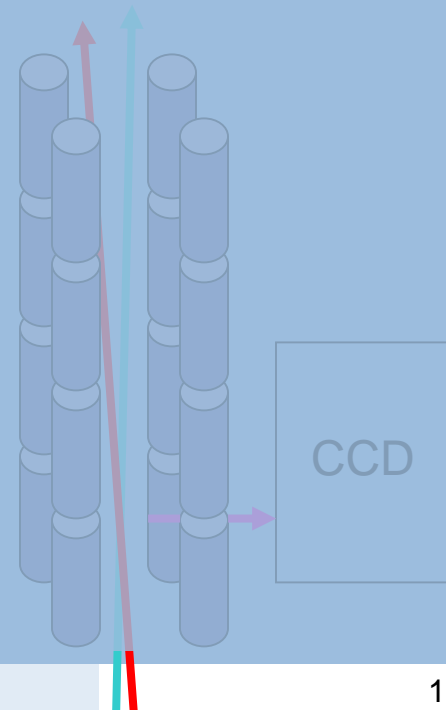

The Enriched Xenon Observatory: polonium tagging

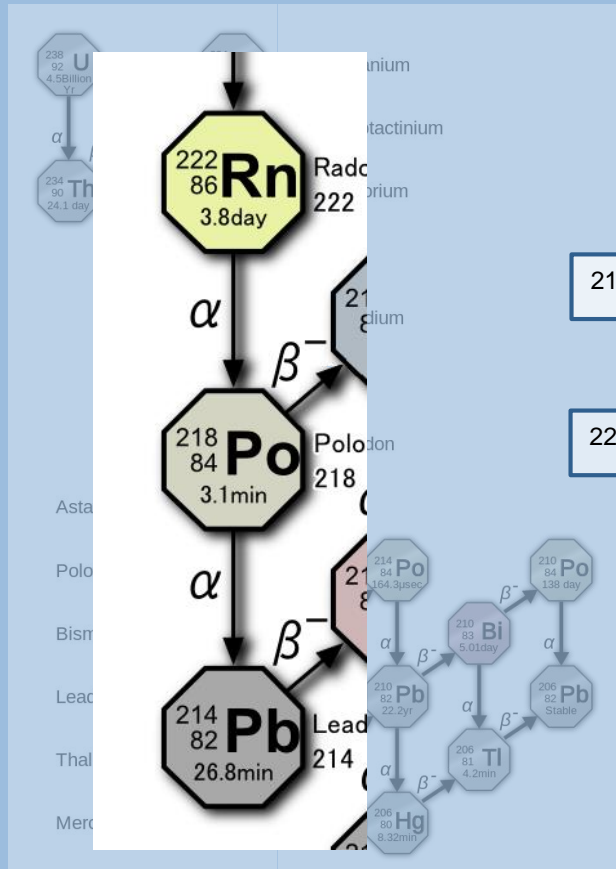

^{218}Po decay

^{222}Rn decay

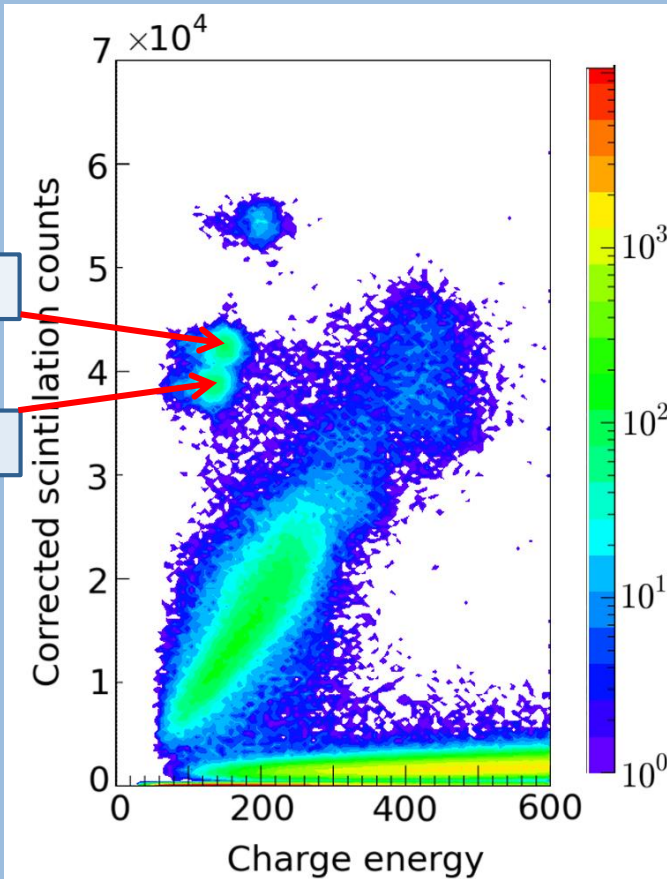

The Enriched Xenon Observatory: polonium tagging technique

Ba⁺ grabber probe

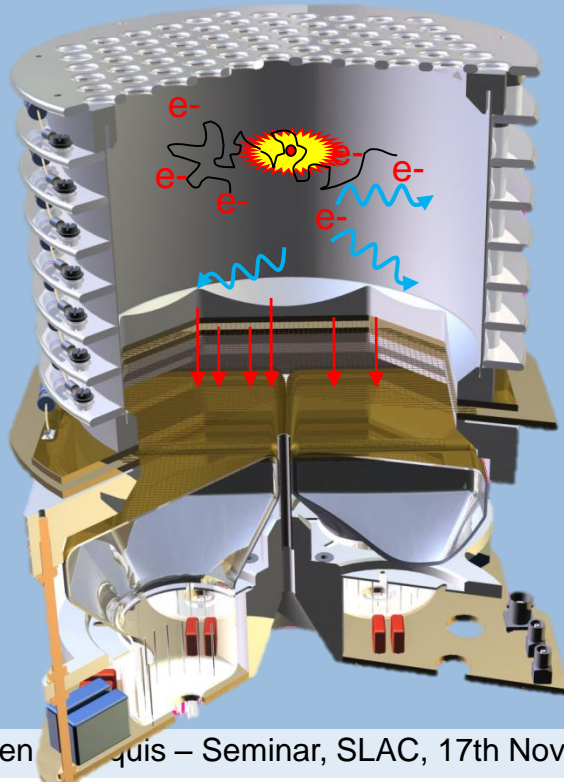

^{222}Rn decay

^{218}Po decay

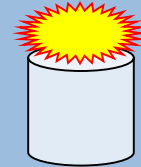

alpha detector

The Enriched Xenon Observatory: steps towards barium / polonium tagging

Important properties of the decay product

- fraction of ions
- drift speed
- neutralisation during drift

Need for a test set-up:

- cryostat
- TPC
- displacement device
- ion grabbing probe → **requires that barium is ionized!!!**

Analysis of alpha decays with EXO-200 data: concept

Important properties of the decay product

- fraction of ions
- drift speed
- neutralisation during drift

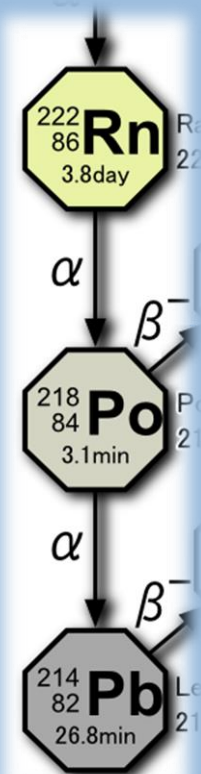

Analysis of alpha decays with EXO-200 data: identification of decays

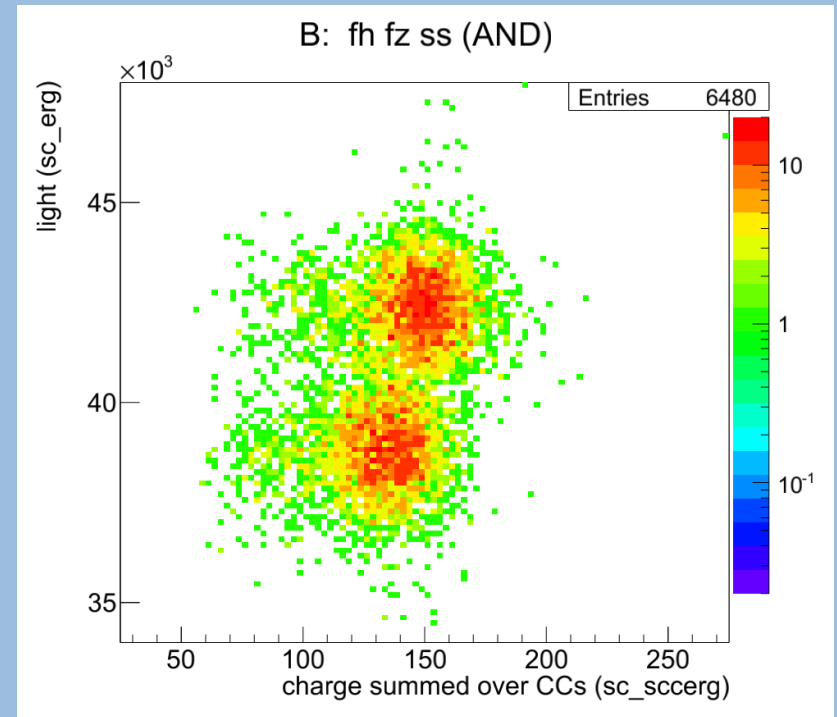
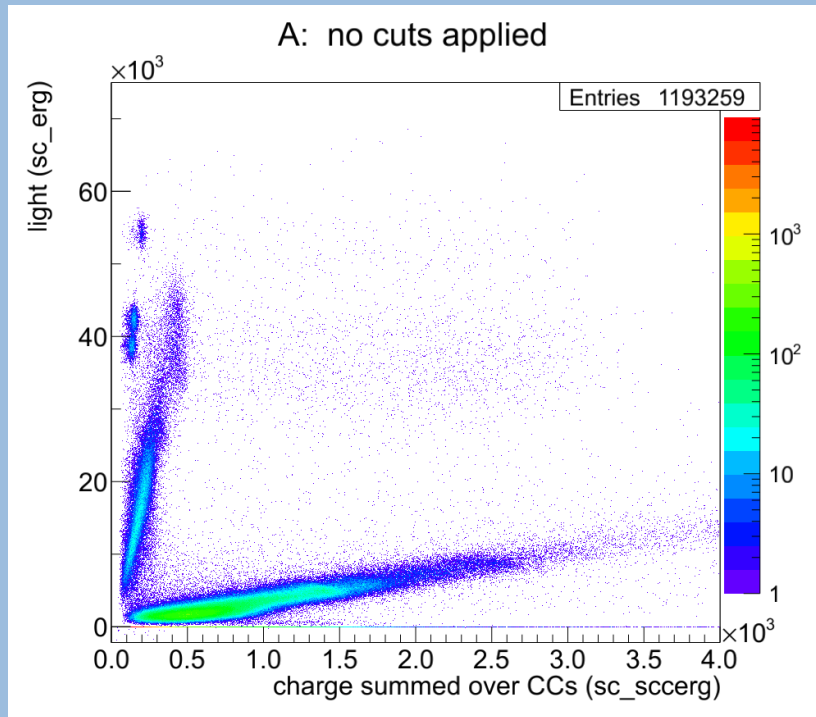

Analysis of alpha decays with EXO-200 data: ^{222}Rn and ^{218}Po populations

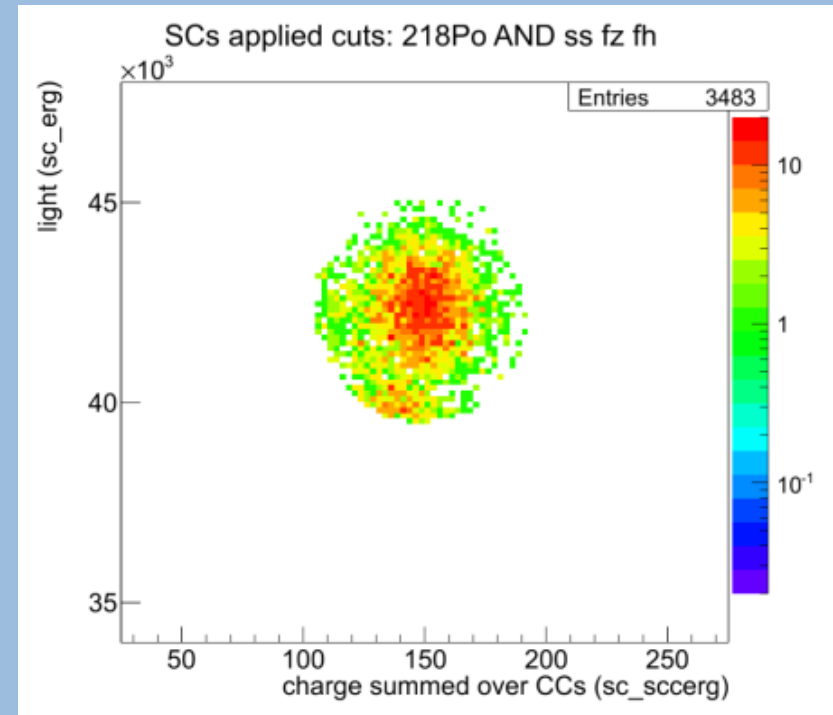
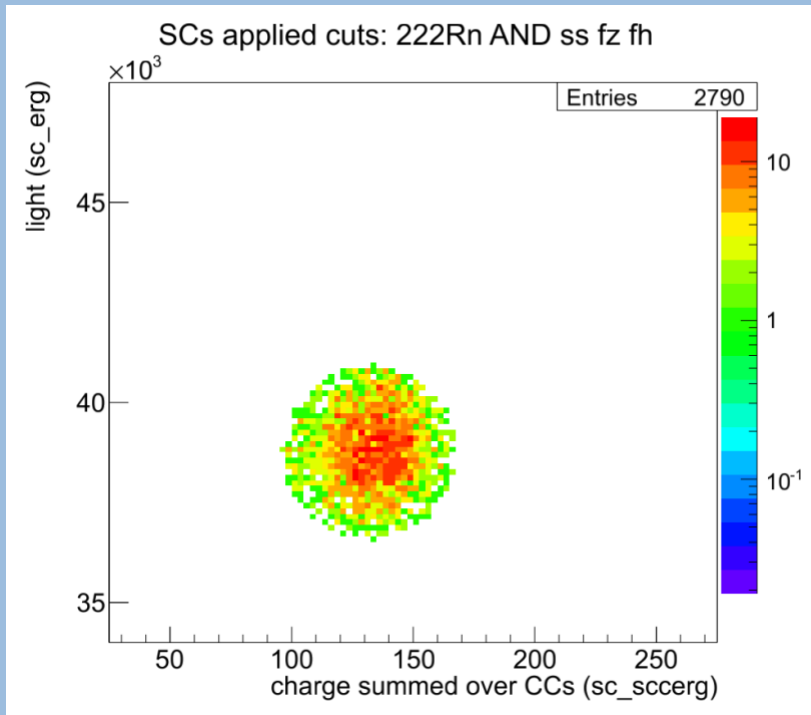

Analysis of alpha decays with EXO-200 data: event linking

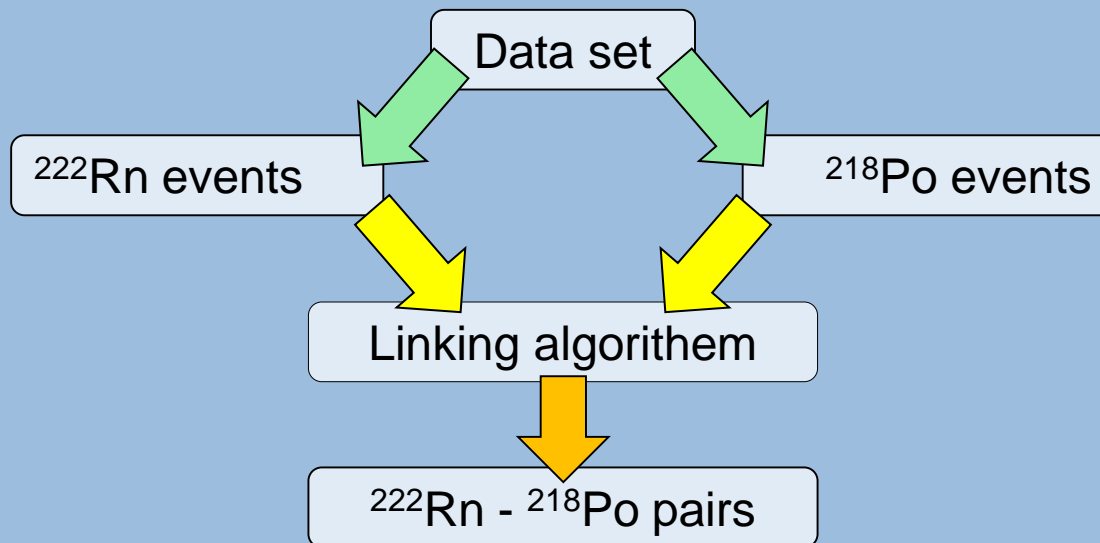

Analysis of alpha decays with EXO-200 data: linking algorithm

$$P(\Delta x, \Delta t) = P(\Delta x|\Delta t) * P(\Delta t)$$

$$P(\Delta t) = \lambda e^{-\lambda \Delta t}$$

$$P(\Delta x|\Delta t) = \frac{1}{\sigma(\Delta t) * \sqrt{2\pi}} e^{-\frac{(\Delta x - \mu)^2}{2 * \sigma(\Delta t)^2}}$$

$$\sigma(\Delta t) = \sigma_0 + \sqrt{\Delta t} * \sigma_1 + \Delta t * \sigma_2$$

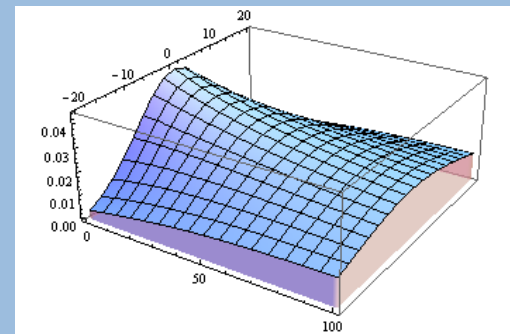
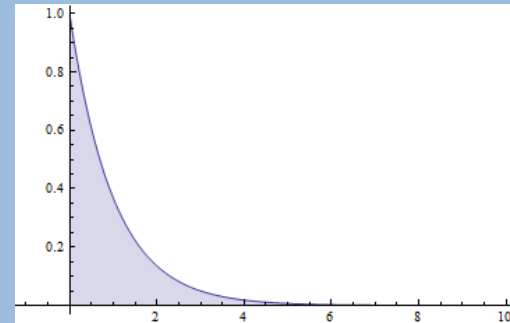

personal communication with L. Dümbsgen

Analysis of alpha decays with EXO-200 data: algorithm verification

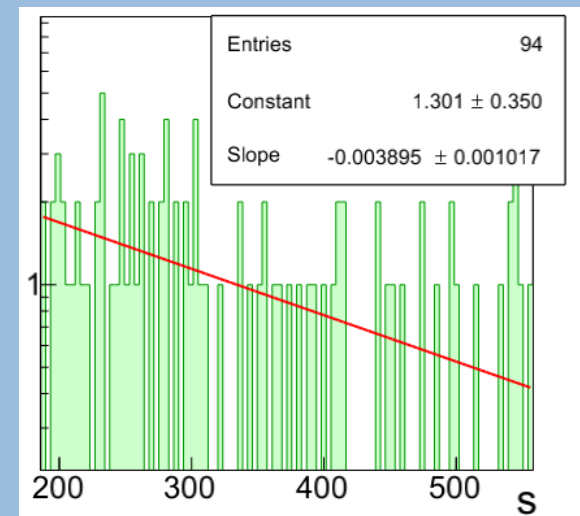
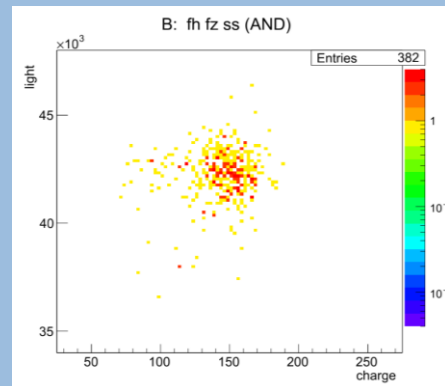
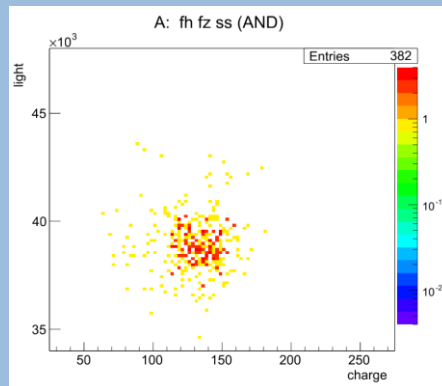
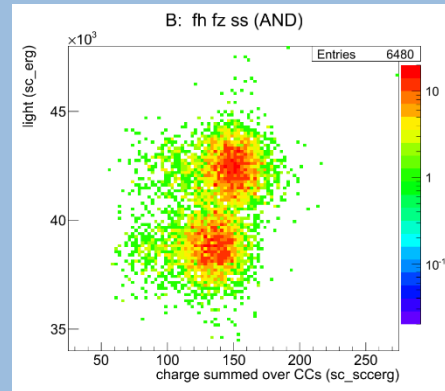
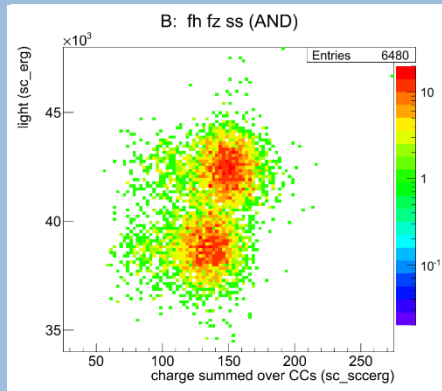

$$T_{1/2} = 178(4)\text{s}$$
$$T_{\text{Po-218}} = 183\text{s}$$

Analysis of alpha decays with EXO-200 data: ^{222}Rn - ^{218}Po pairs

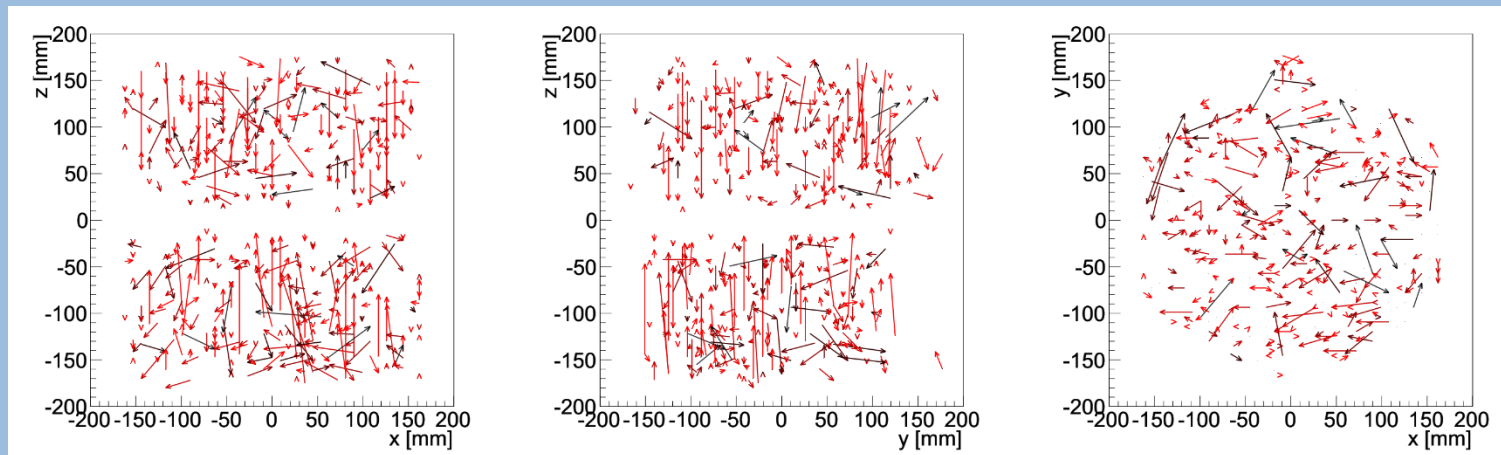

Analysis of alpha decays with EXO-200 data: ^{222}Rn - ^{218}Po pairs

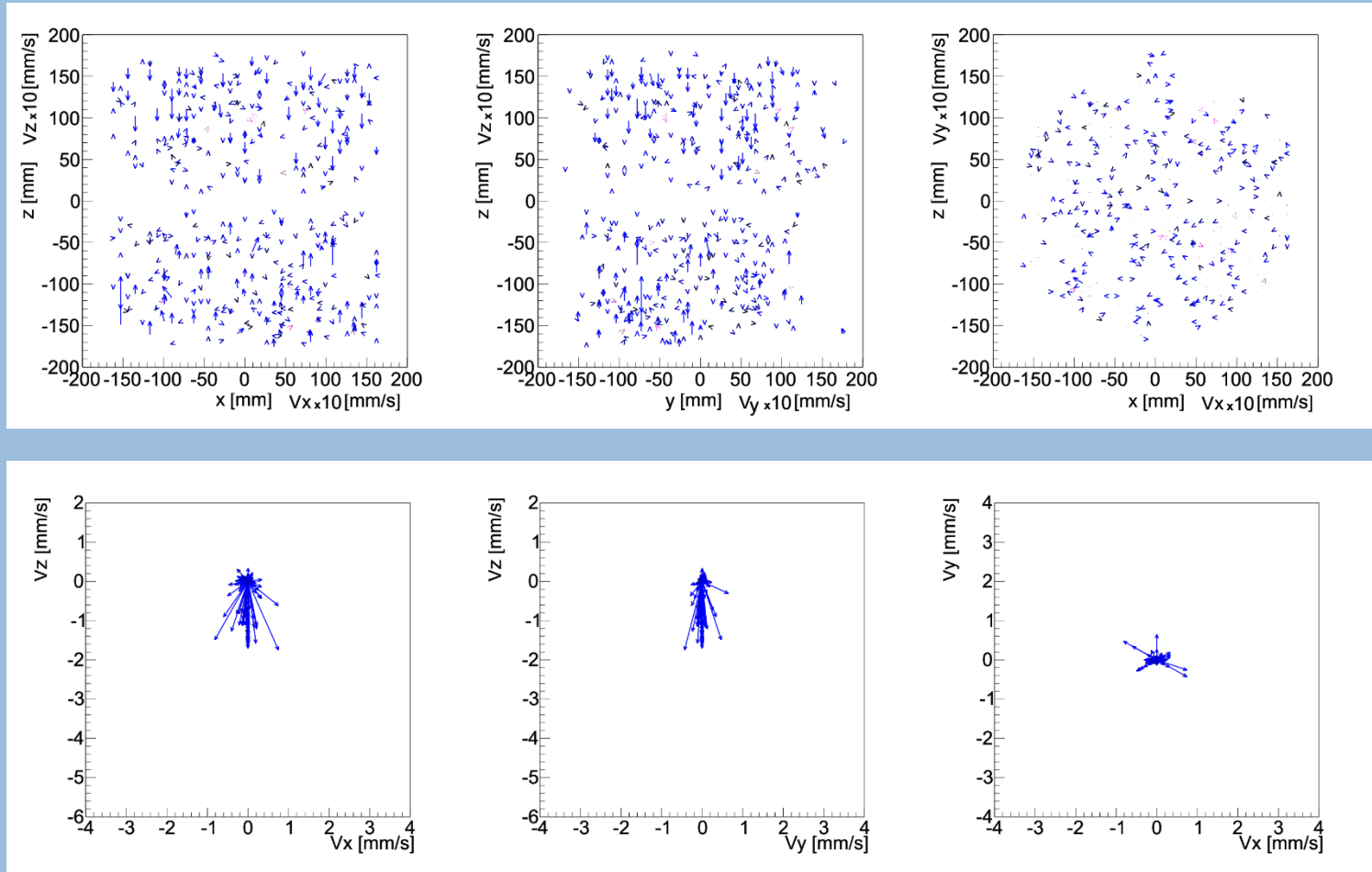

Analysis of alpha decays with EXO-200 data: ^{222}Rn - ^{218}Po pairs

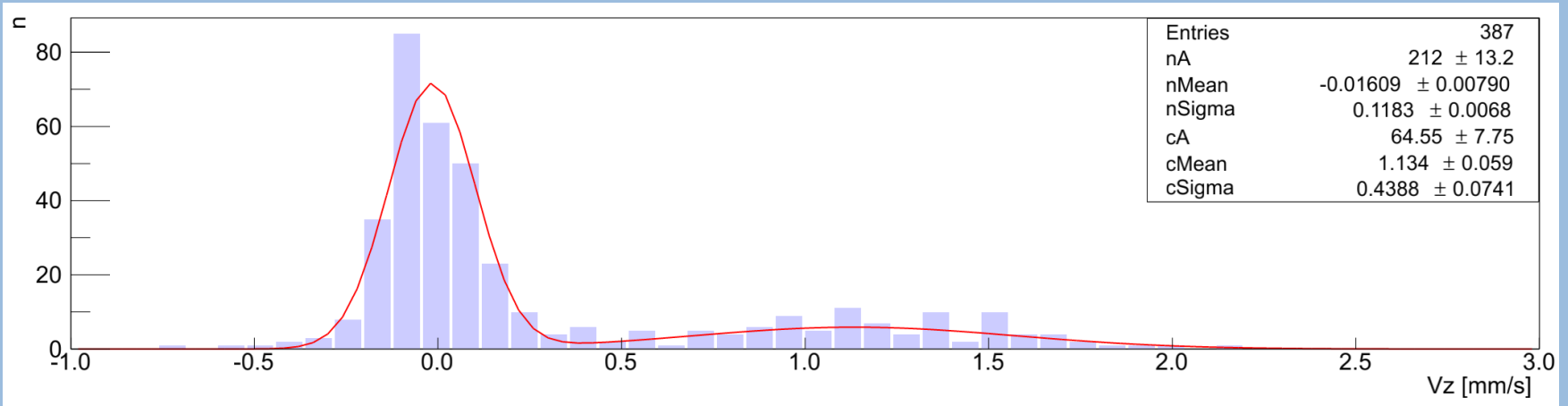

Analysis of alpha decays with EXO-200 data: fair linking

$$\Delta t < \Delta t_{fair} := \frac{|z| - z_{min}}{v_{max}}$$

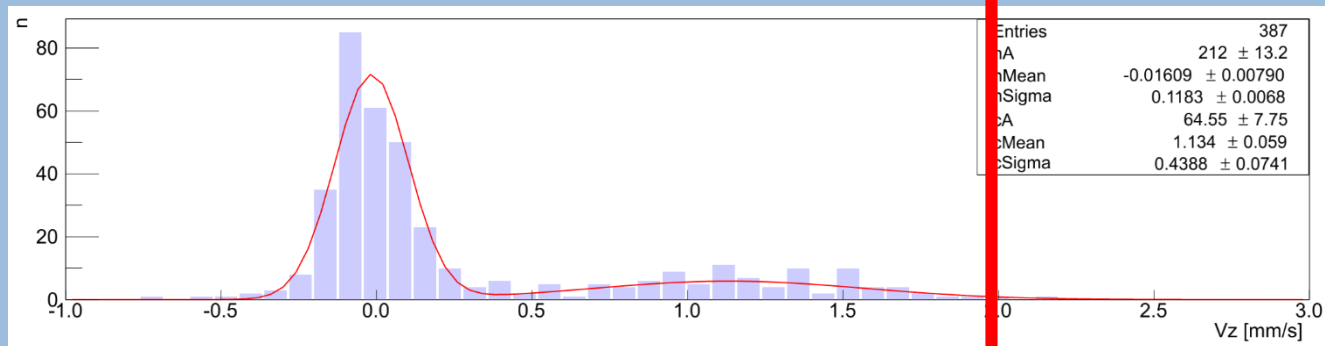

Analysis of alpha decays with EXO-200 data: $^{222}\text{Rn} - ^{218}\text{Po}$ pairs

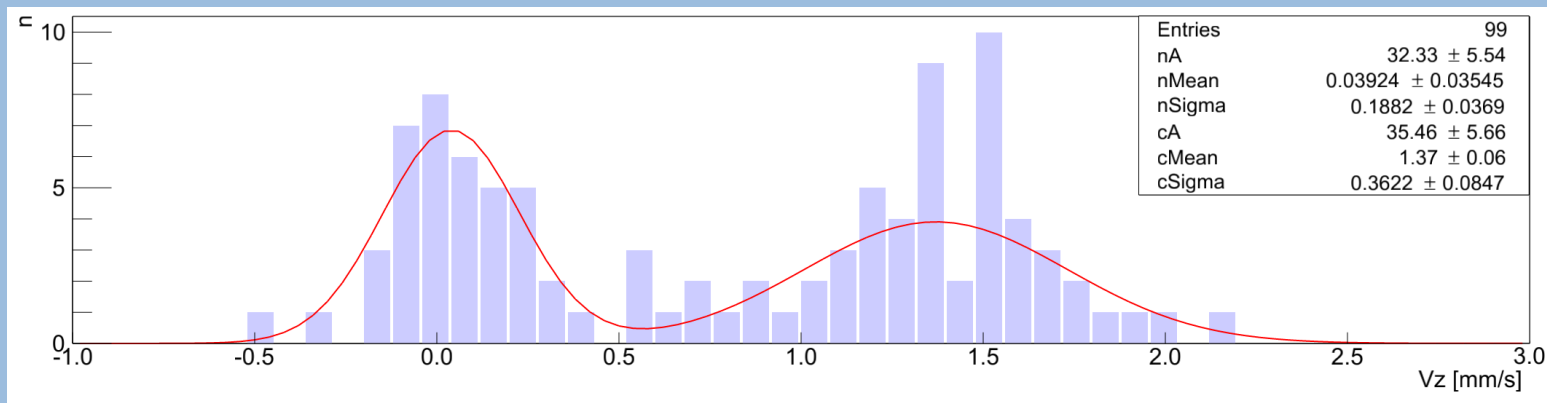

Ion fraction: 52(10)%
Drift speed: 1.4(4) mm/s

Drift field: 376(5) V/cm

The EXO-100 facility: overview

Components:

- Cryostat
- Gashandling
- Slow control
- Safety systems

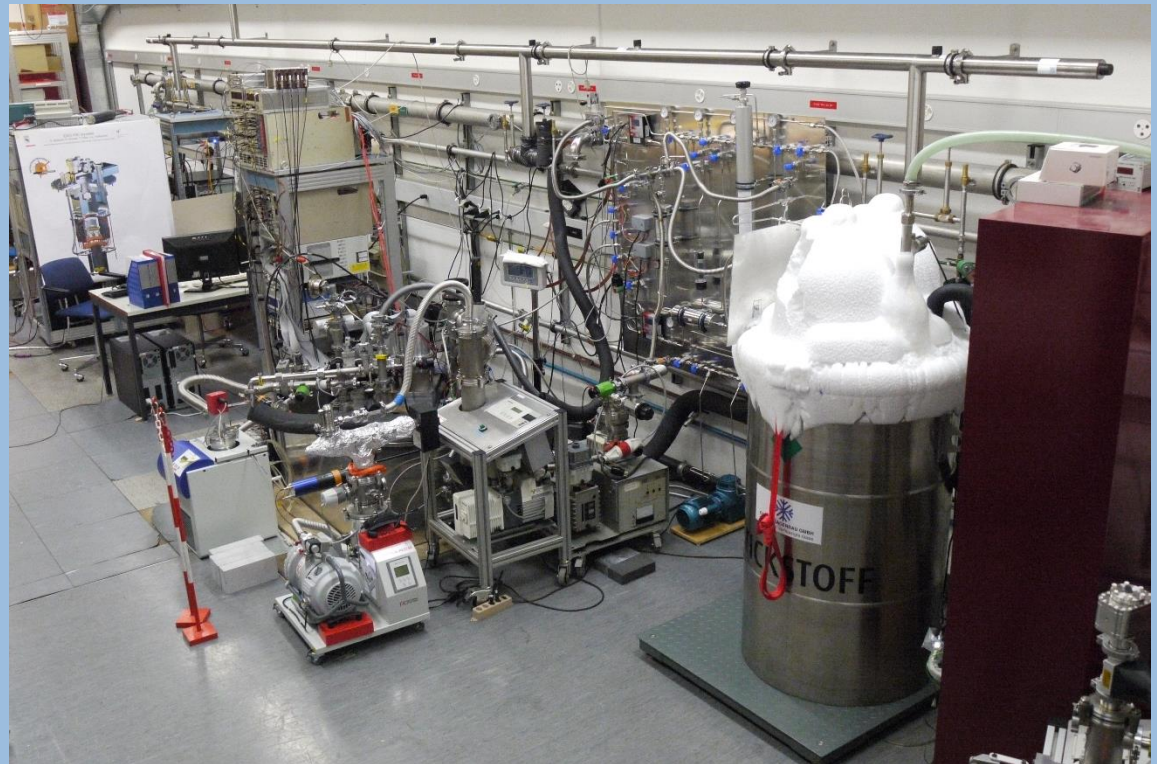

LABORATORIUM FÜR HOCHENERGIEPHYSIK

LHEP
UNIVERSITÄT BERN

The EXO-100 facility: cryostat

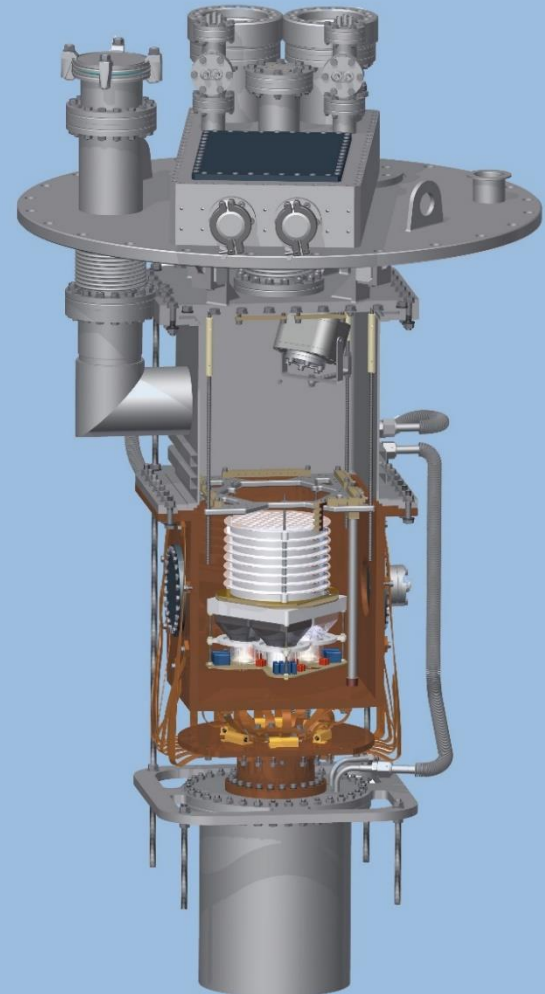
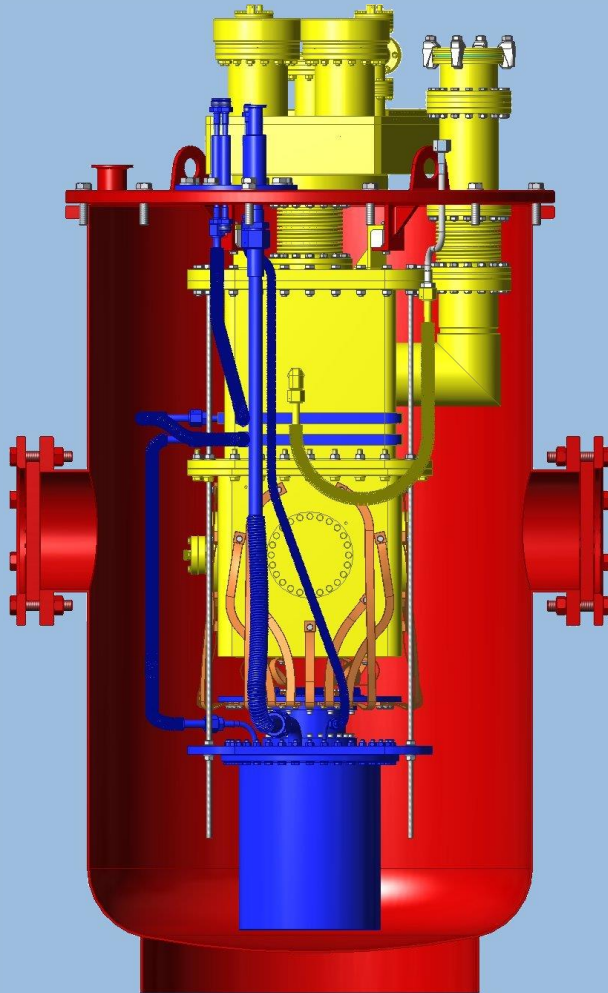

The EXO-100 facility: cryostat

xenon:

T_b : 165.1K at 1bar

T_{tr} : 161.4K at 0.82bar

$\Delta t \sim 4K$

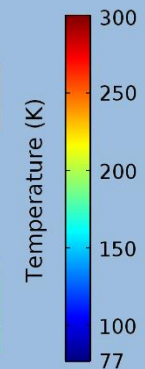
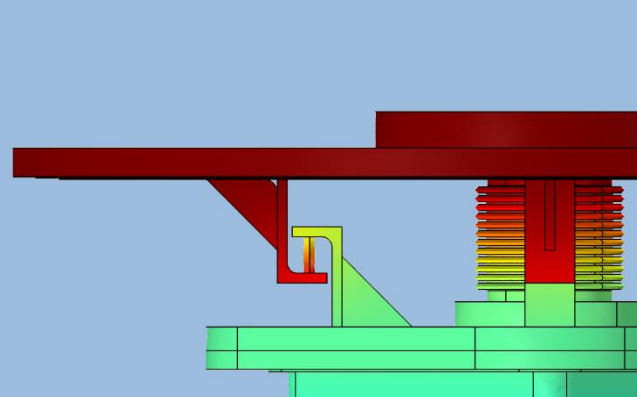
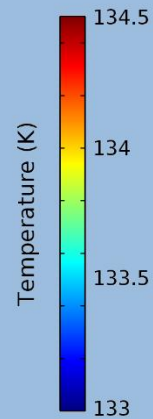
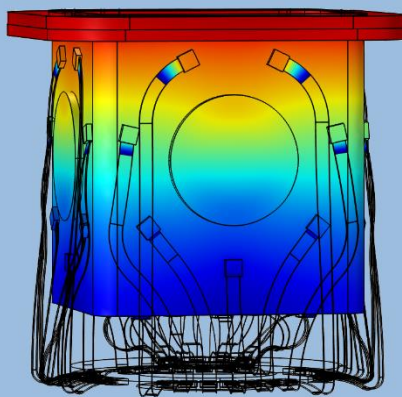
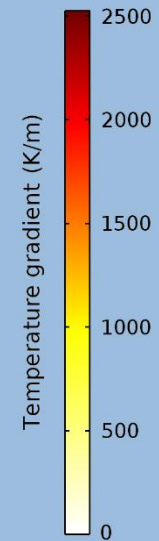
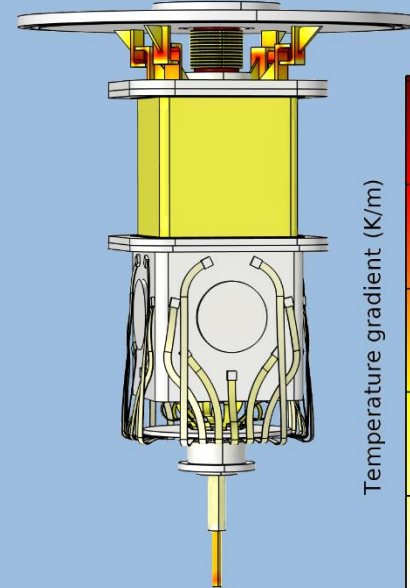
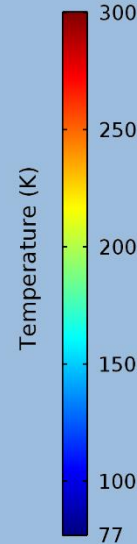
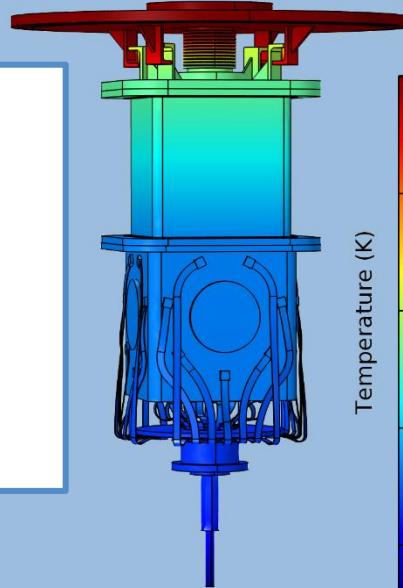

The EXO-100 facility: cryostat

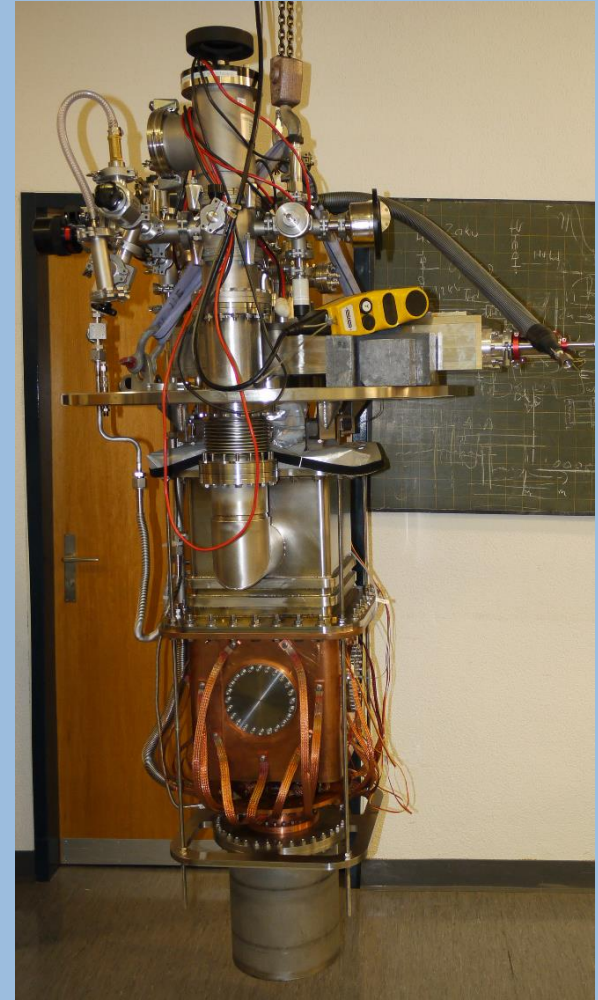

The EXO-100 facility: slow control

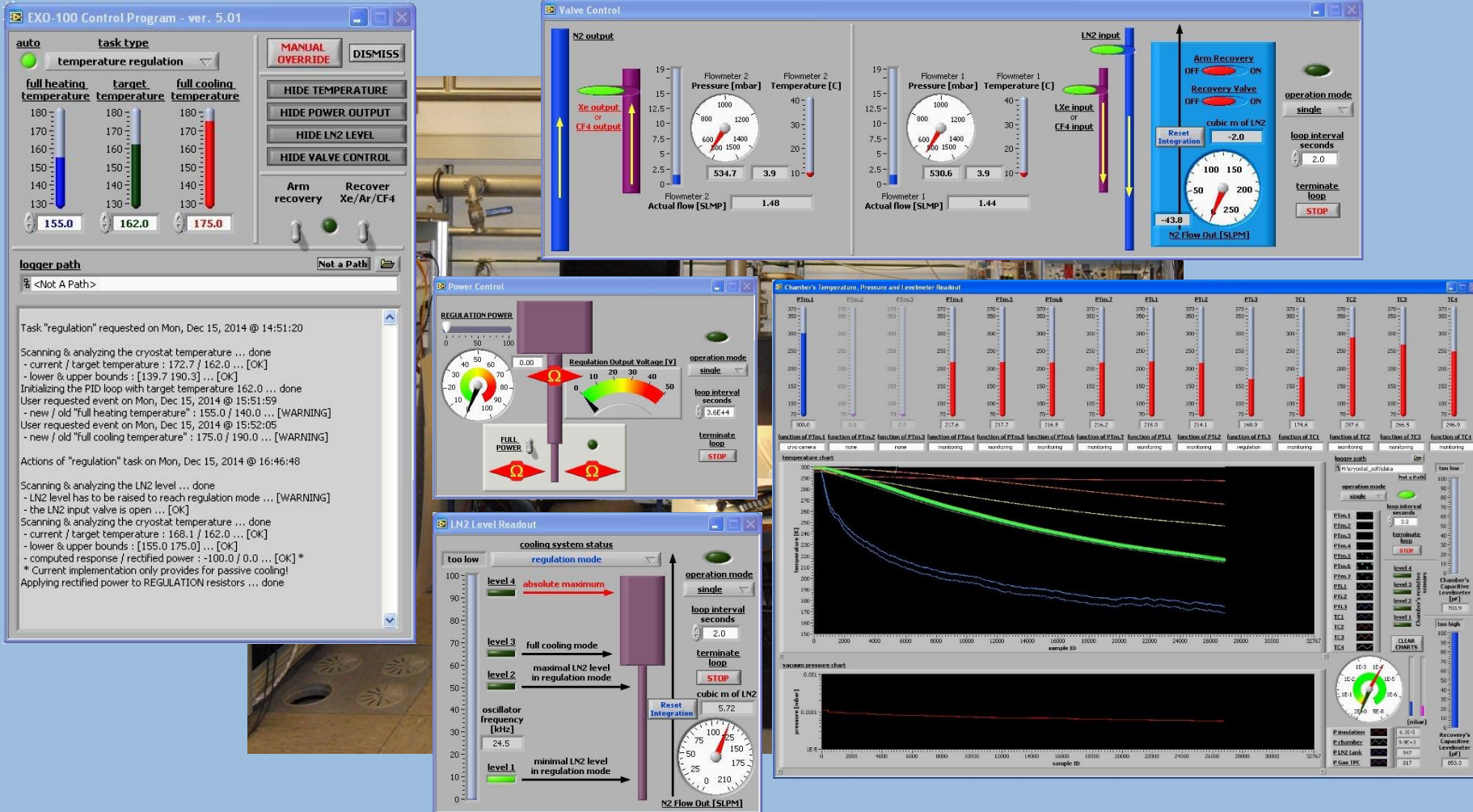

The EXO-100 facility: gas handling system

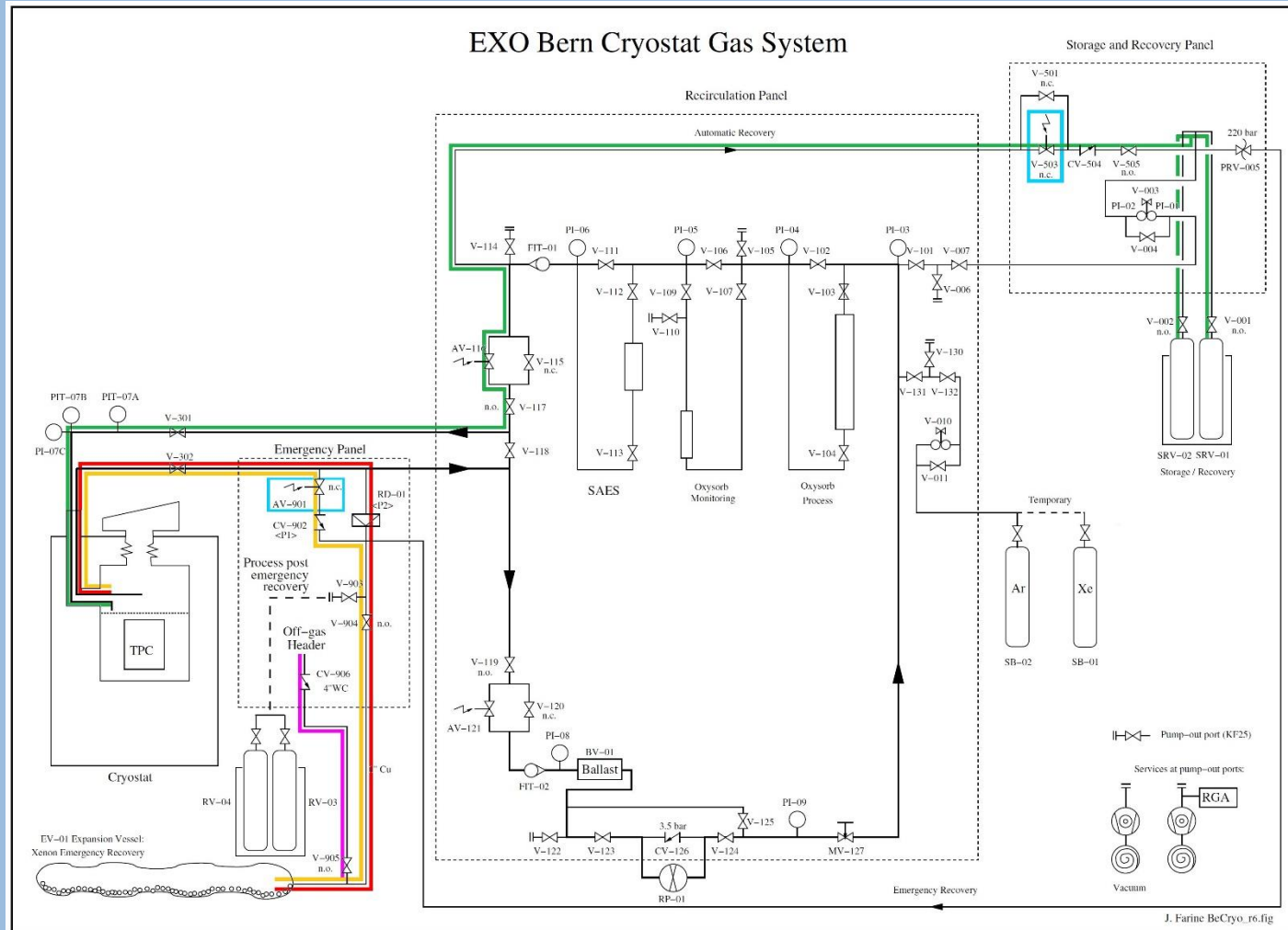

The EXO-100 facility: summary

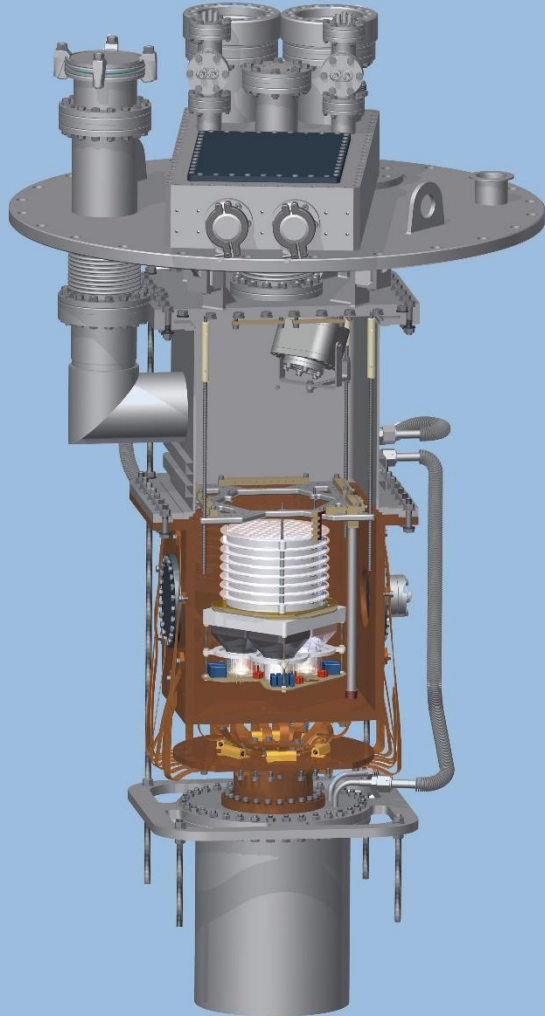

Very versatile cryogenic facility

able to operate with LAr, LCF₄ and LXe over a large temperature range of 100 K

can be interfaced with closed-loop gas purification system (LXe, LCF₄ operation)

The EXO-100 facility: TPC

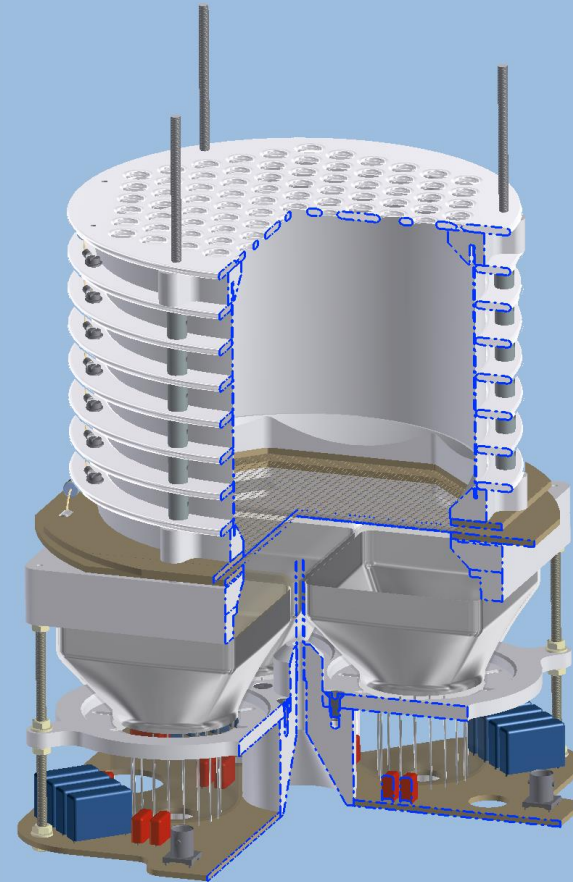
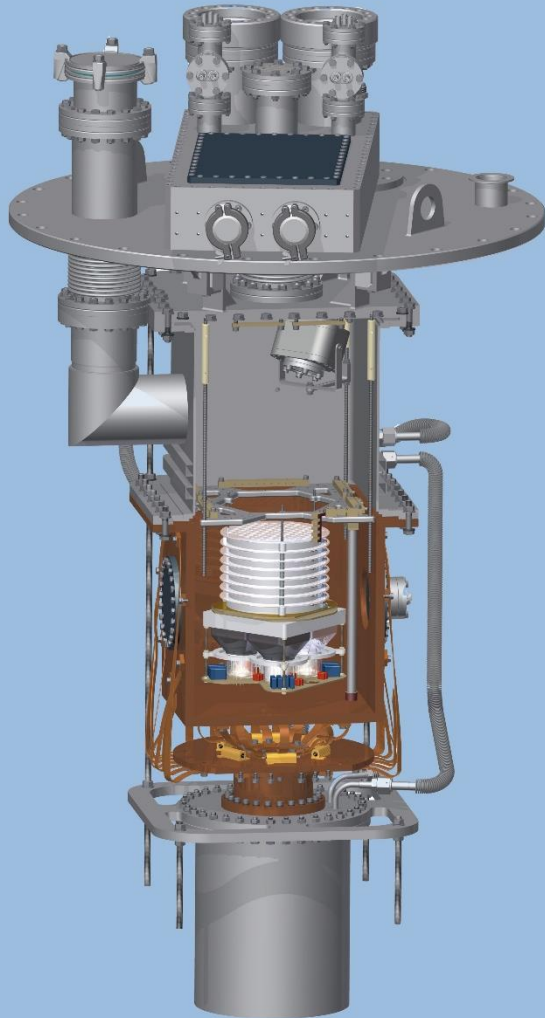

The EXO-100 facility: TPC

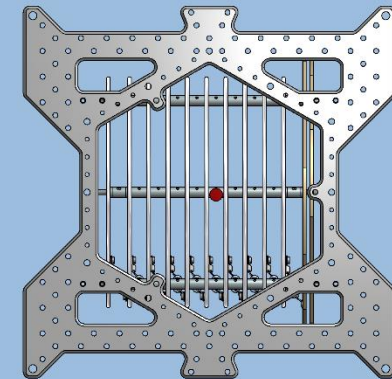
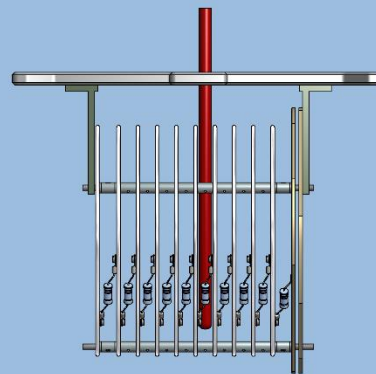
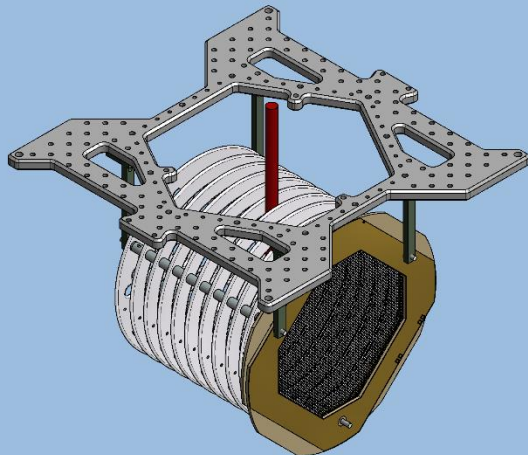
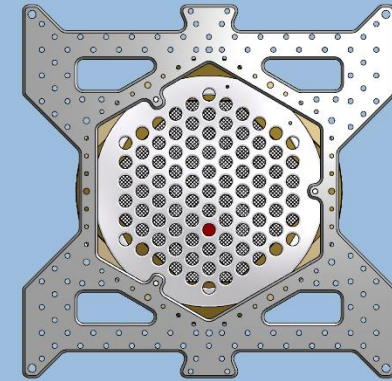
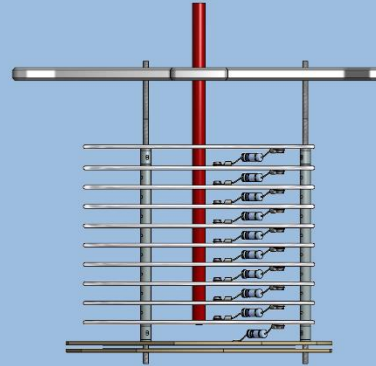
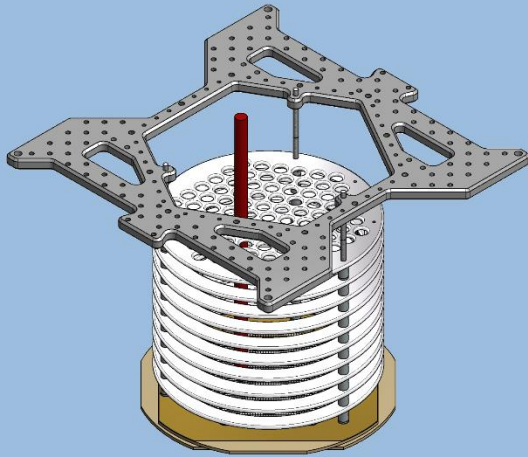

The EXO-100 facility: TPC

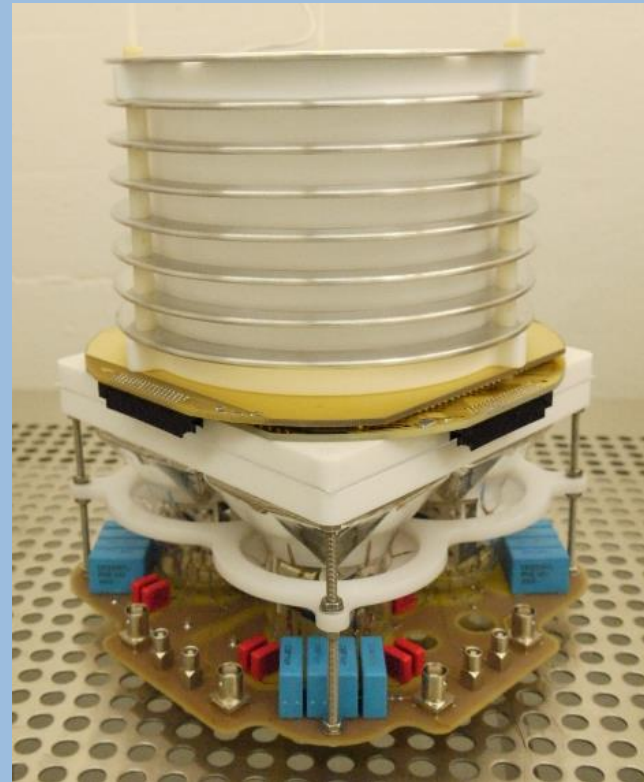
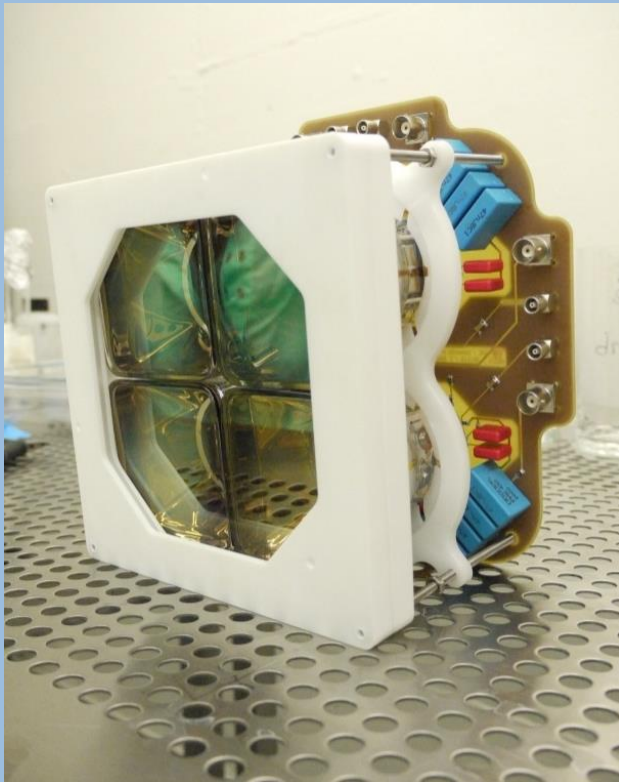

The EXO-100 facility: TPC

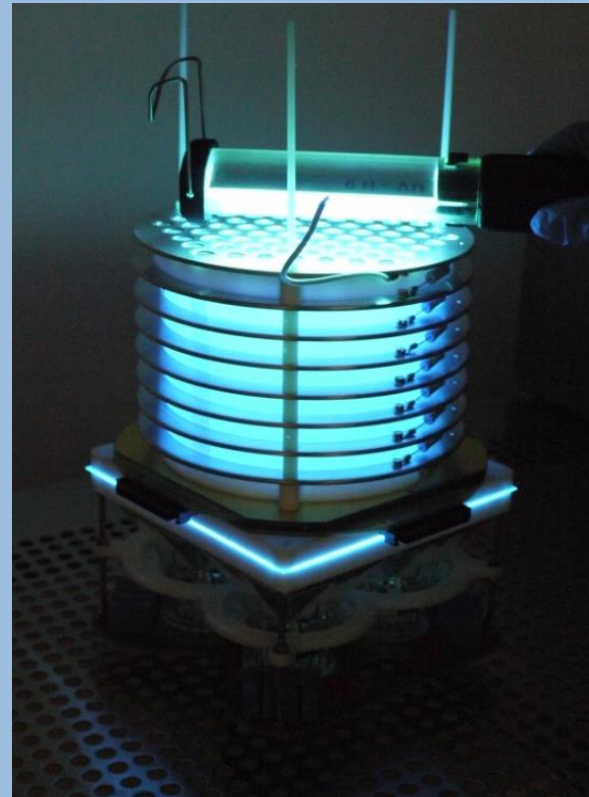
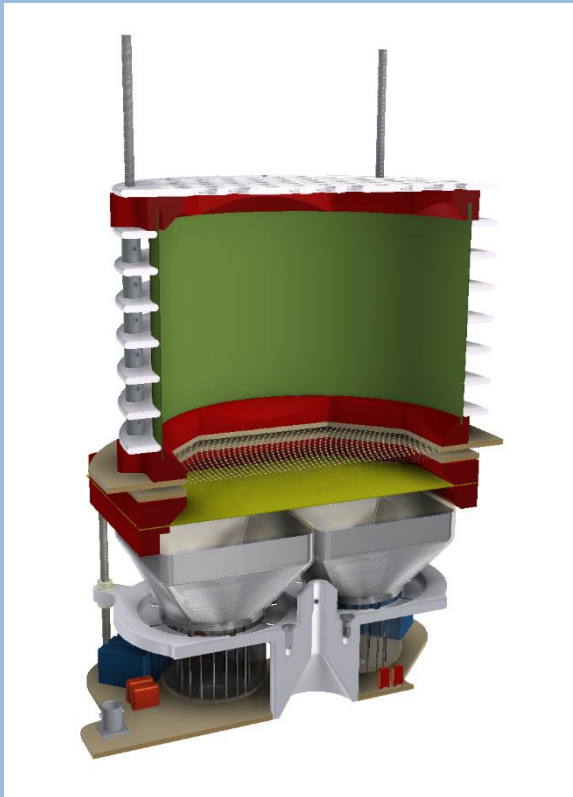

The EXO-100 facility: displacement device

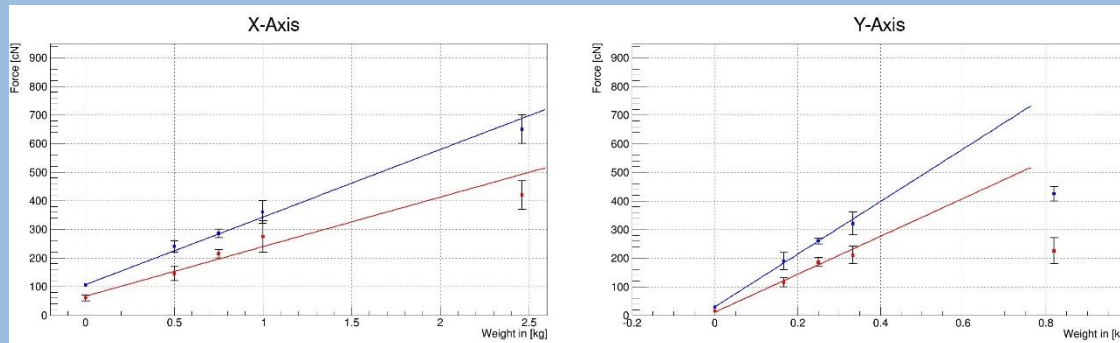
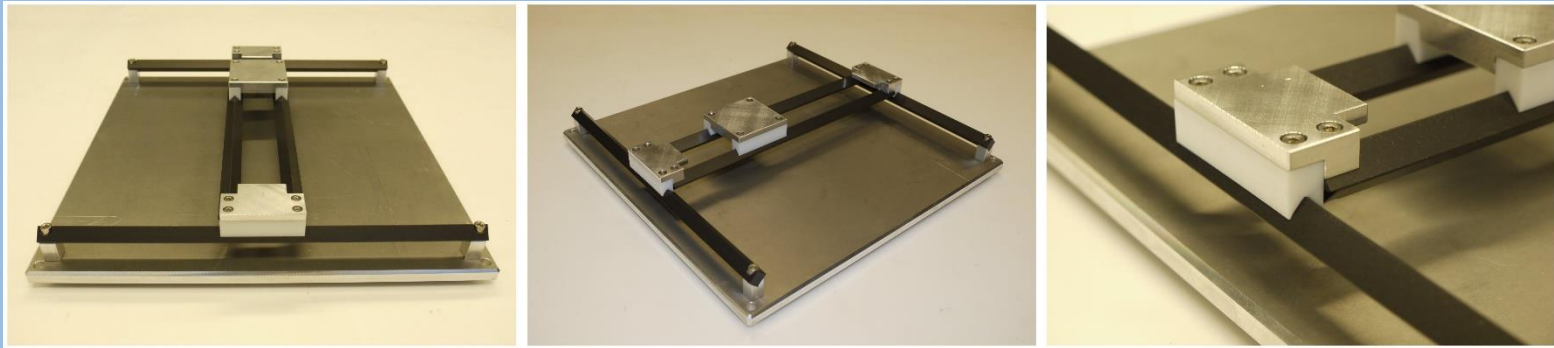

The EXO-100 facility: cryo-camera

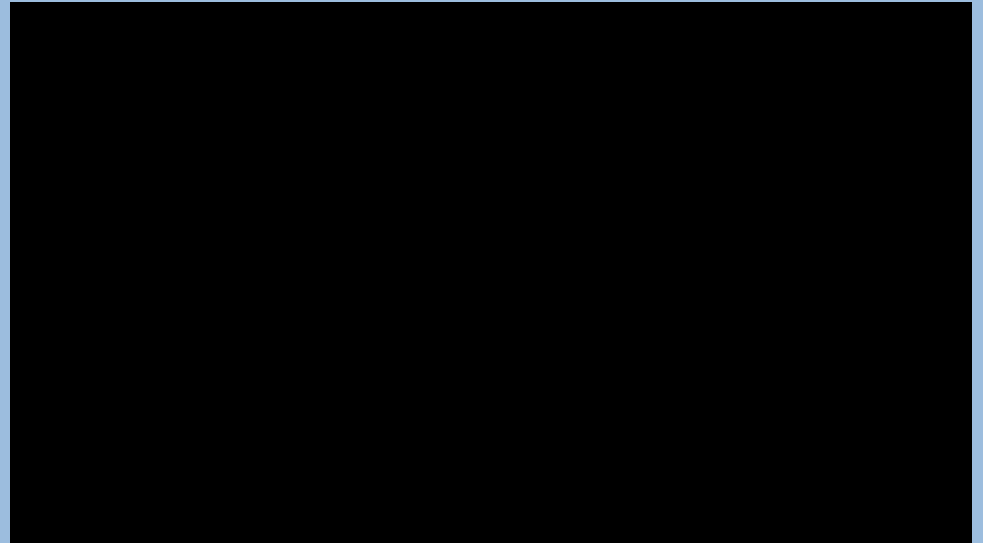

The EXO-100 facility: detector assembly

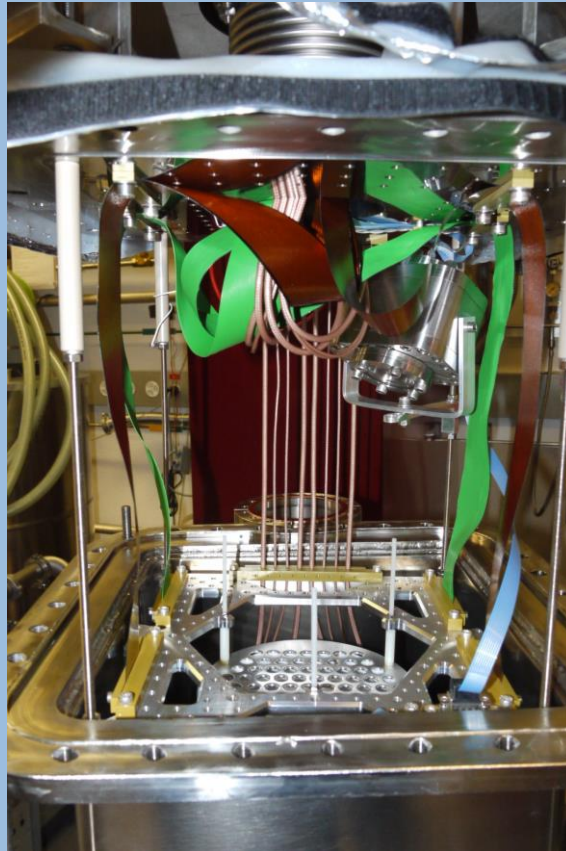
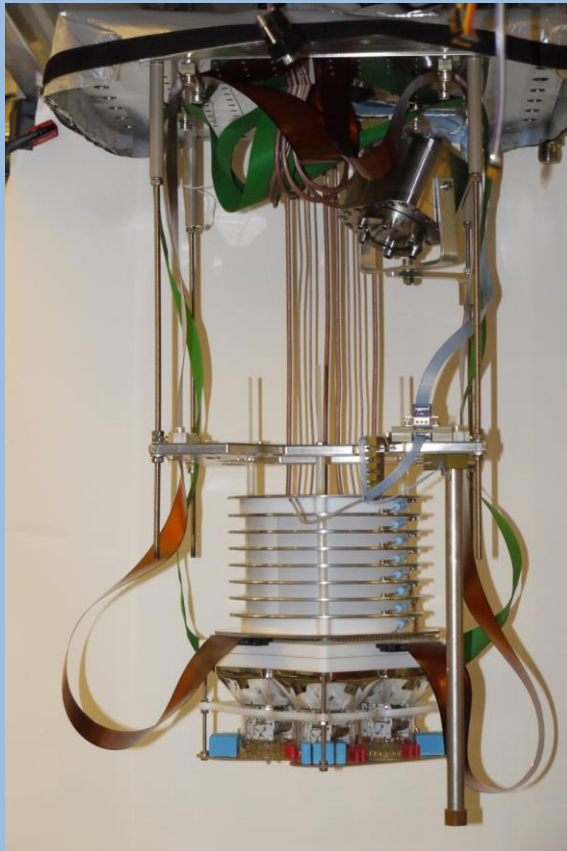

The EXO-100 facility: recorded events in liquid argon

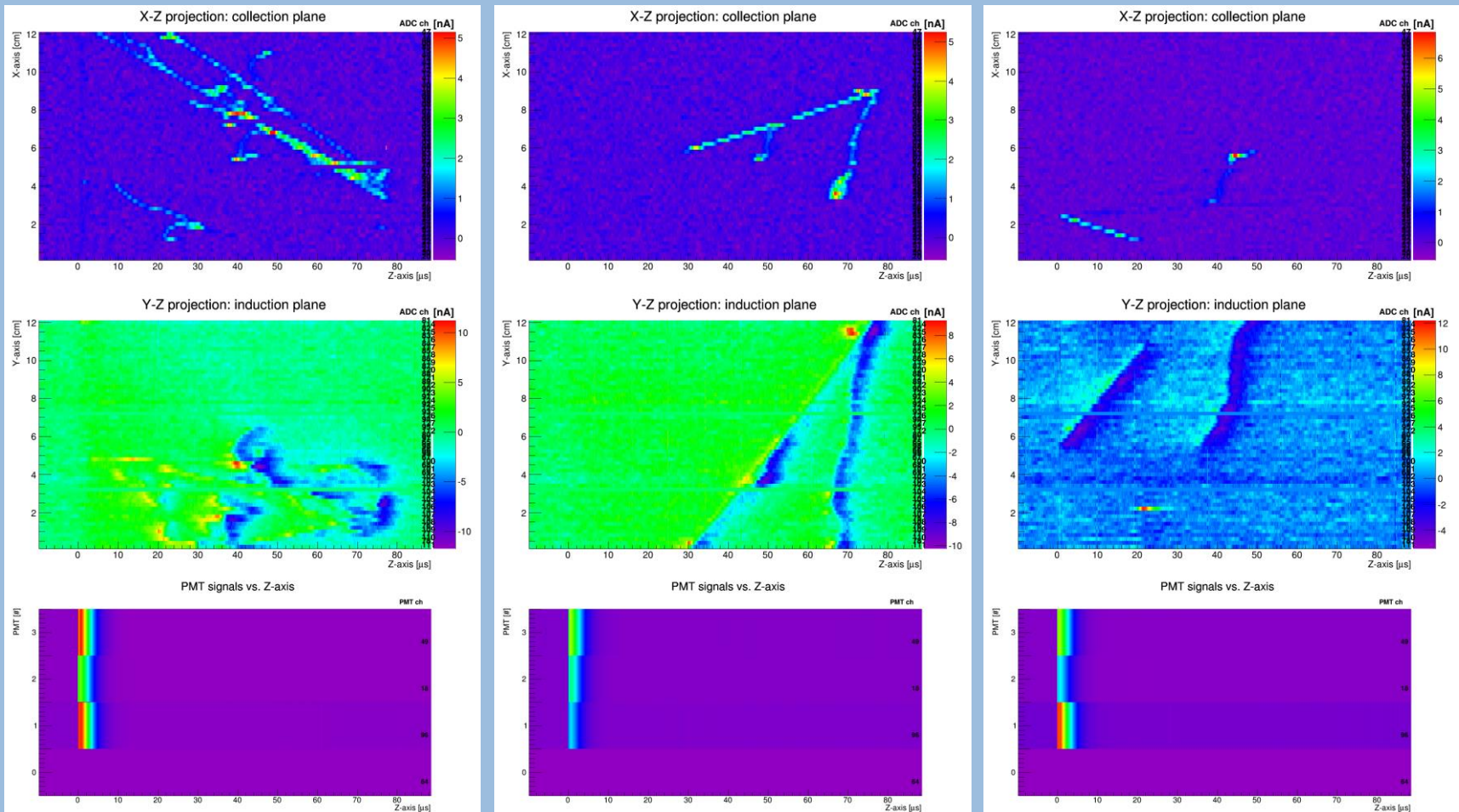

High voltage tests with EXO-100: R&D for EXO

Situation in EXO-200:

- designed for -75kV
- -10kV glitches occur
- data taking at -8kV

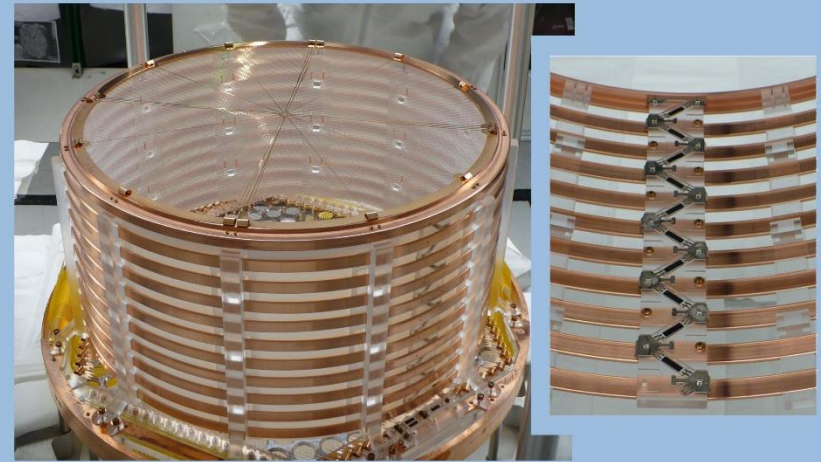

Three hypotheses:

- acrylic struts (stored in N_2 for years)
- breakdown between rings and cryostat
- voltage divider

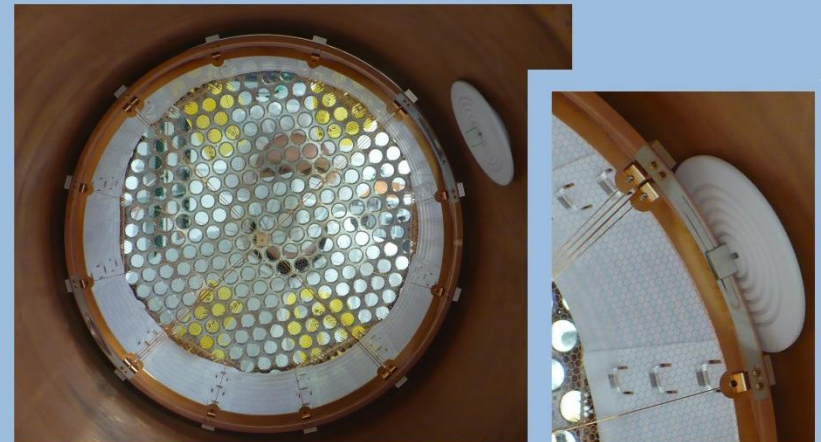

High voltage tests with EXO-100: miniEXO mock-up

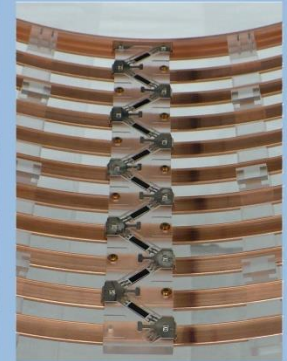
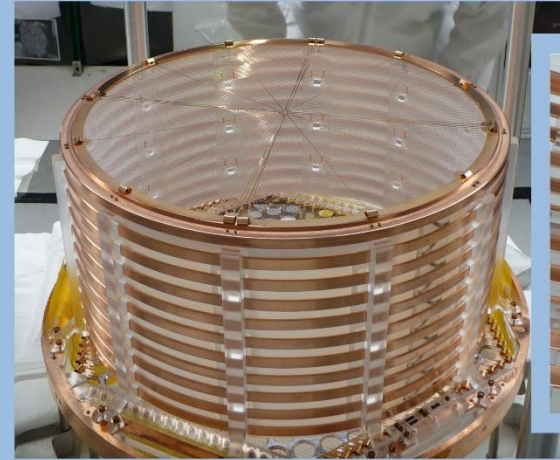
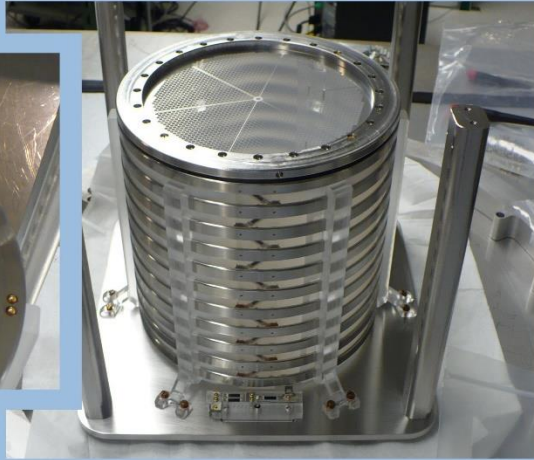
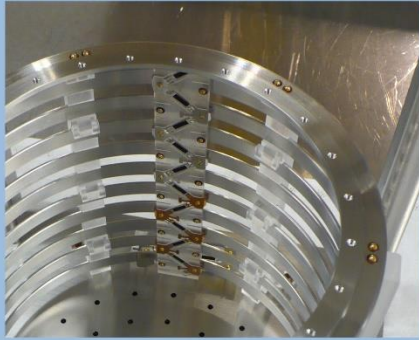
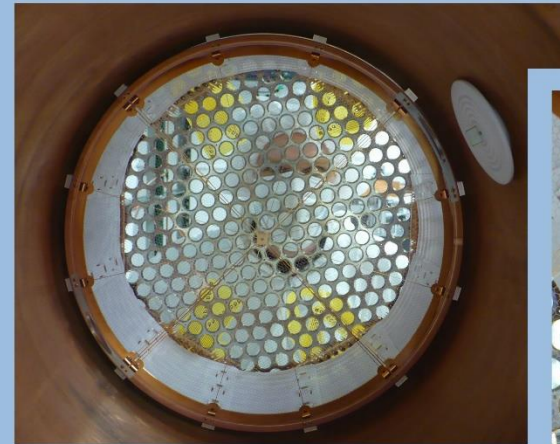
**SLAC**

High voltage tests with EXO-100: miniEXO installation

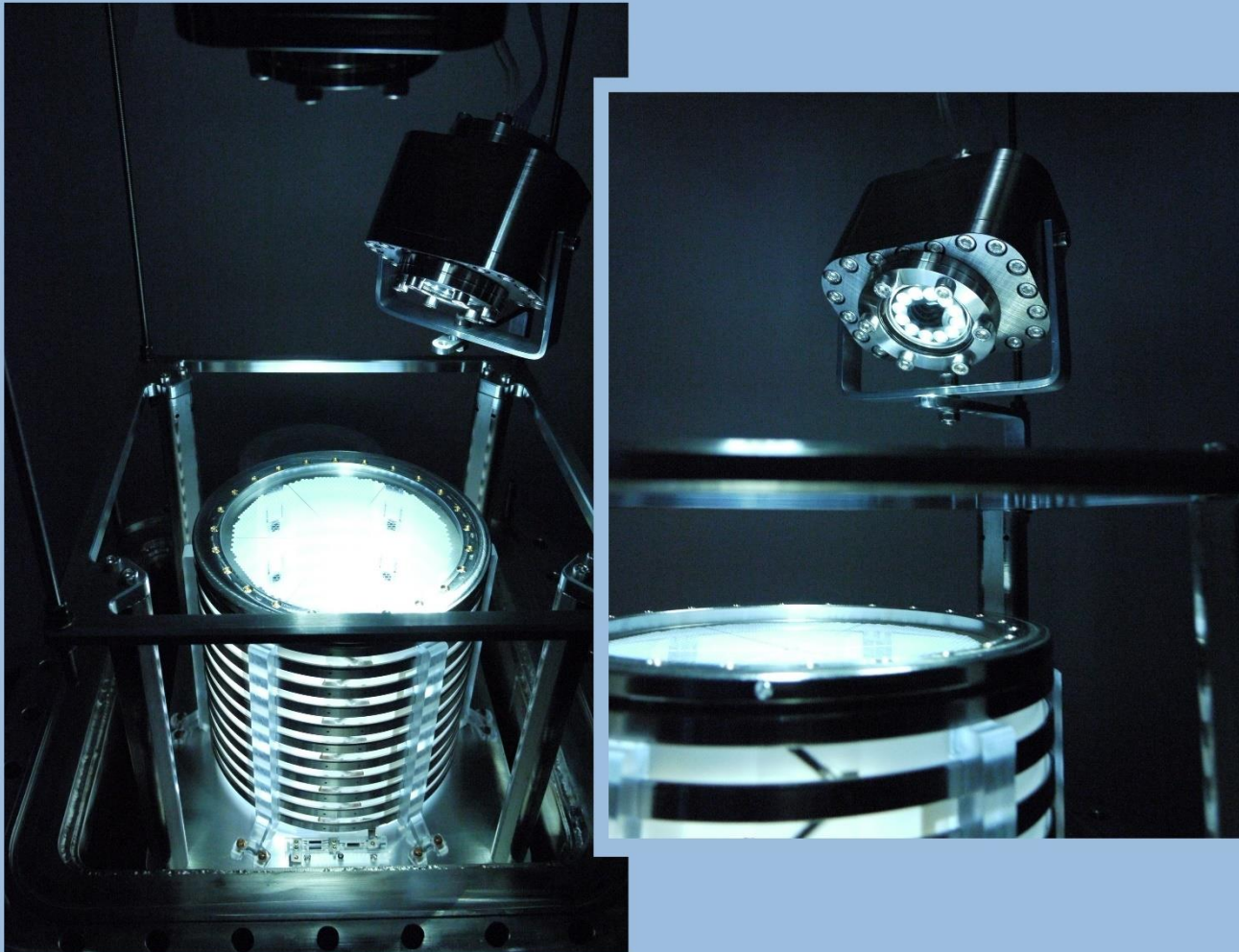

High voltage tests with EXO-100: a captured breakdown

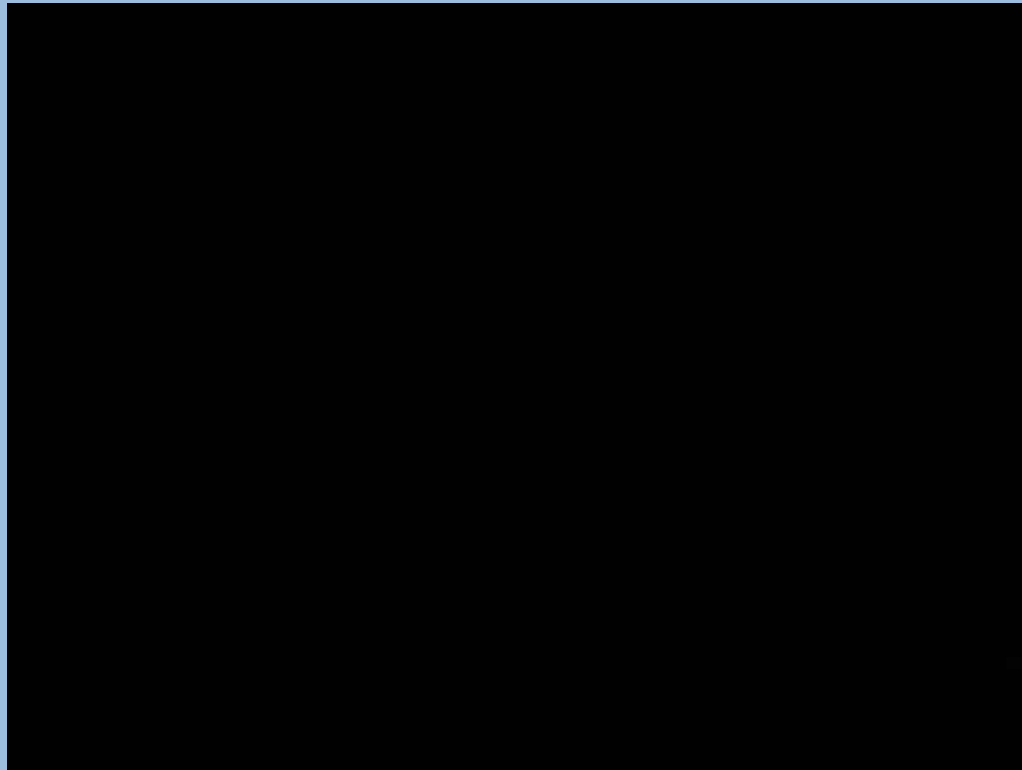

High voltage tests with EXO-100: conclusions

Observations:

- reached a voltage of -50kV
- no breakdown at voltage divider
- all breakdowns in gap – close to struts
- agreement with FEM study

Three hypotheses:

- voltage divider
- acrylic struts
- breakdown between rings and cryostat

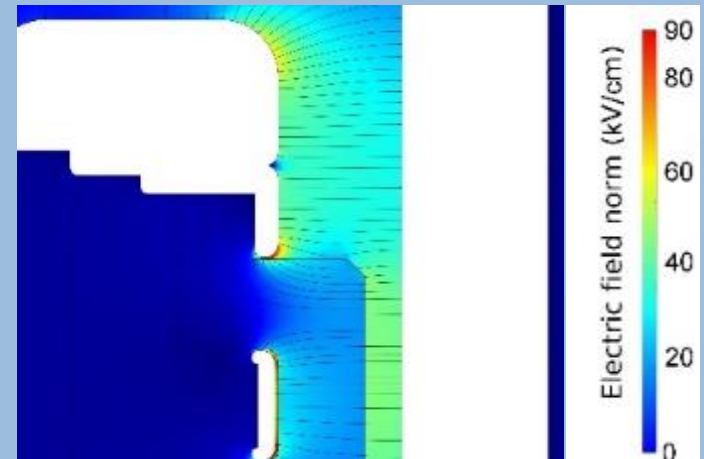

cathode at -40kV

Conclusions

Data analysis:

- developed a linking algorithm
- measure properties for ^{218}Po

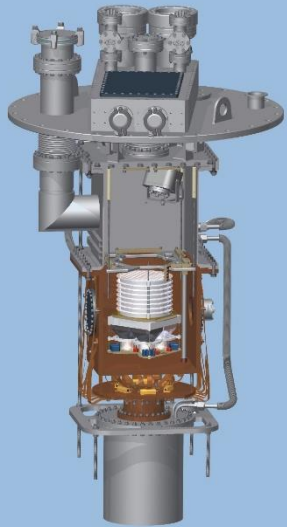
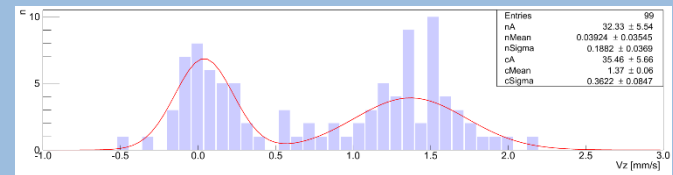

Hardware:

- constructed and operated the EXO-100 facility
 - used to for HV tests with miniEXO
- designed and operated the EXO-100 TPC
- cryo-camera, displacement device, level meters, ...

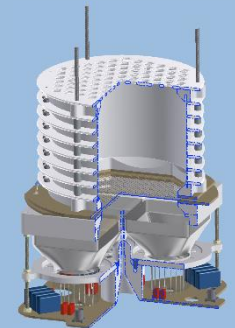

u^b

^b
UNIVERSITÄT
BERN

AEC
ALBERT EINSTEIN CENTER
FOR FUNDAMENTAL PHYSICS

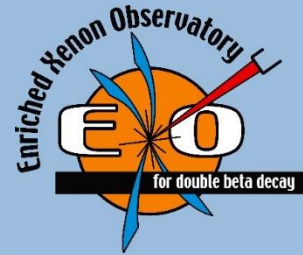

Thank you!



heig-*vd*

Haute Ecole d'Ingénierie et de Gestion
du Canton de Vaud