

Search for $t\bar{t}H$ production in ATLAS

María Moreno Llácer

II. Physikalisches Institut, Georg-August-Universität Göttingen

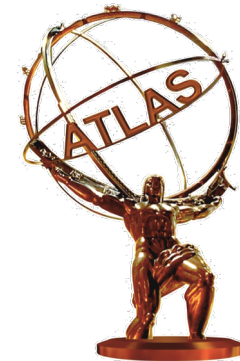

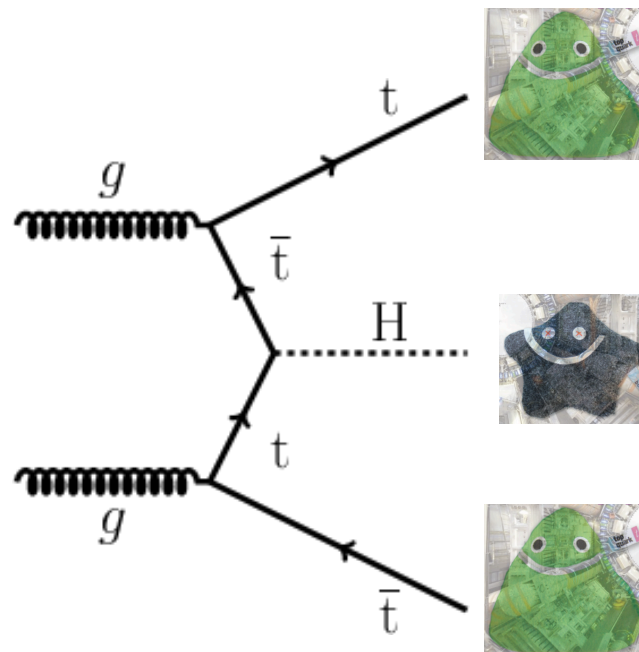

- Introduction and motivation
- Search for $t\bar{t}H$ production in ATLAS
 - $t\bar{t}H, H \rightarrow b\bar{b}$
 - $t\bar{t}H, H \rightarrow WW, \tau\tau, ZZ$
 - $t\bar{t}H, H \rightarrow \gamma\gamma$
- Combined results
- Outlook



The quest for the Higgs boson

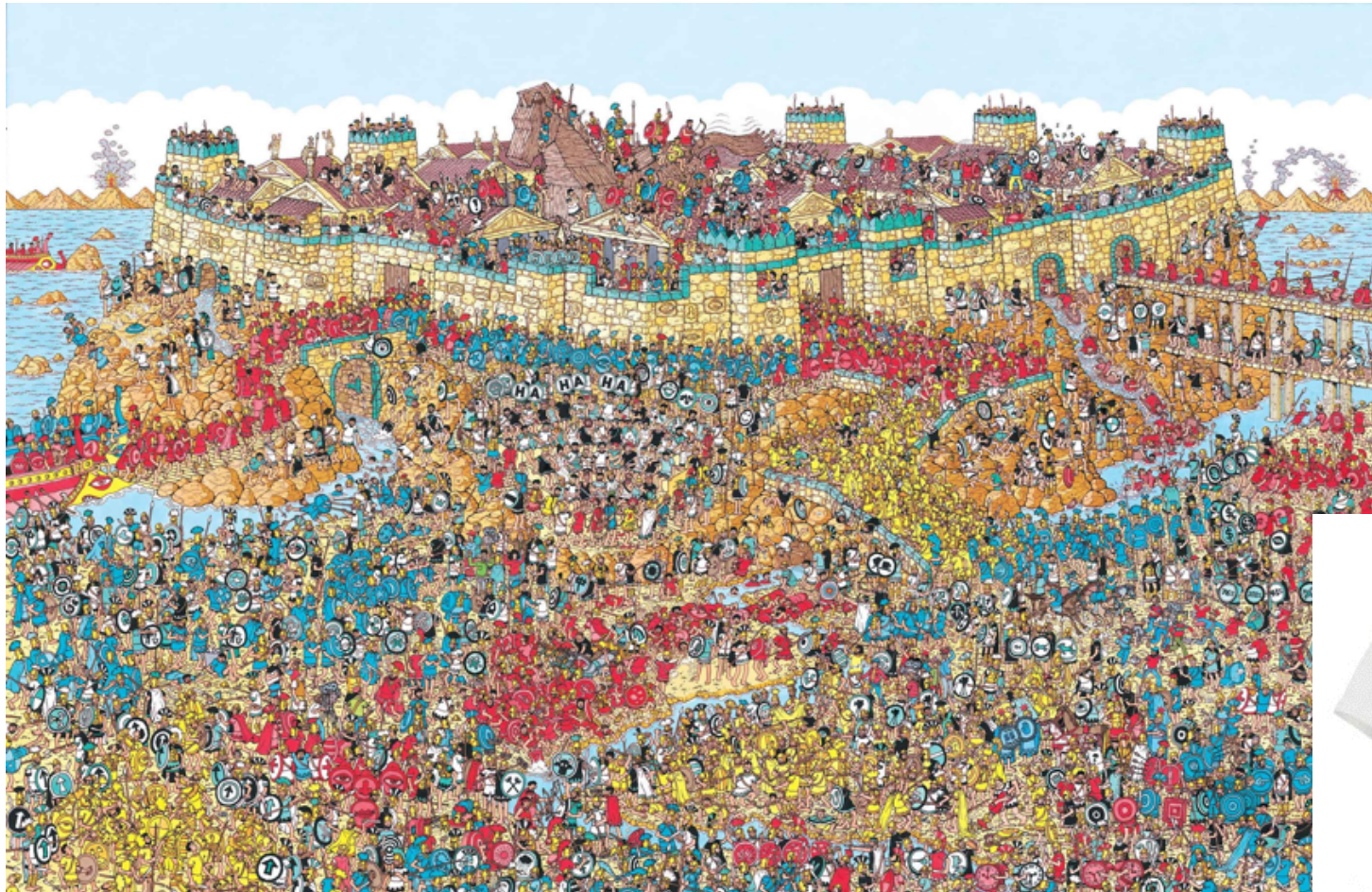

Save the date:
July 4th 2012





Higgs boson discovered in $H \rightarrow ZZ^*$, $H \rightarrow \gamma\gamma$ and $H \rightarrow WW^*$ decay modes with 2012 data
• $m_H \sim 125.6$ GeV, $J^P = 0^+$

$H \rightarrow \gamma\gamma$

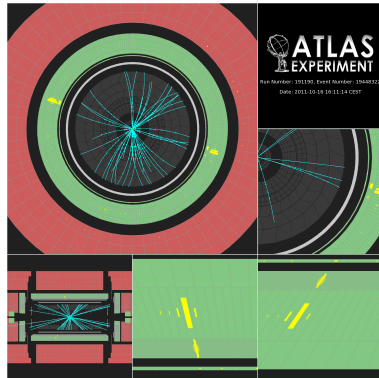
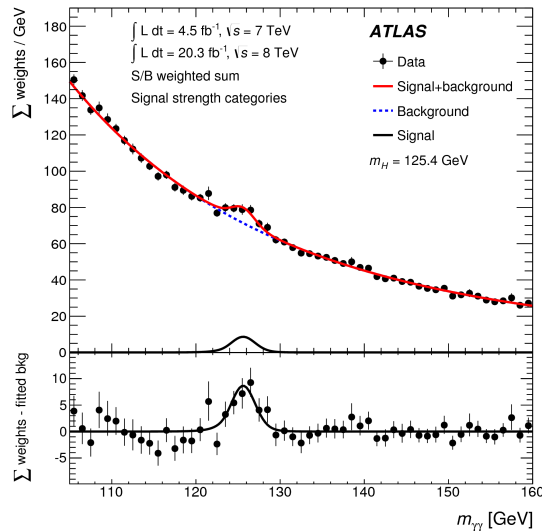

$H \rightarrow ZZ^*$

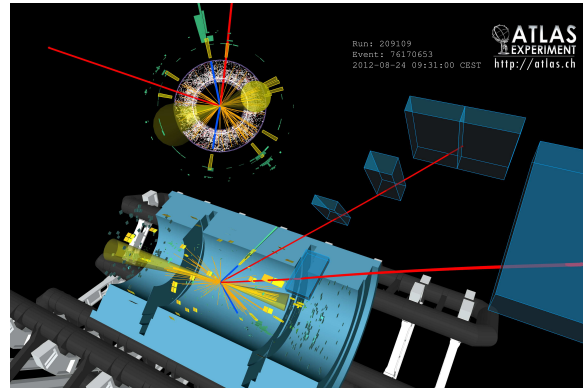
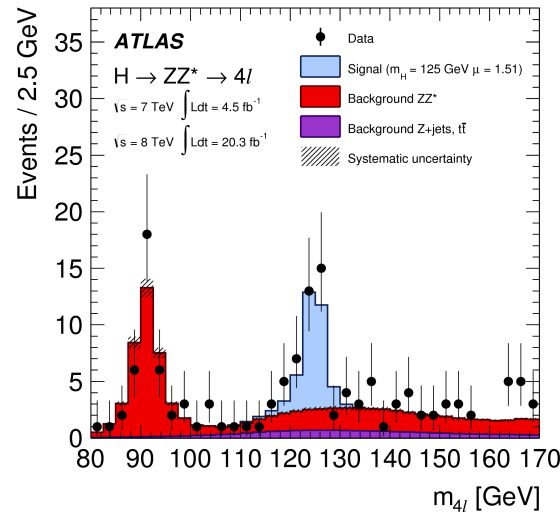

$H \rightarrow WW^*$

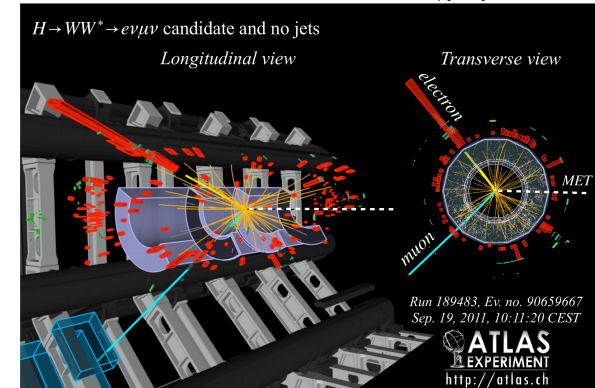
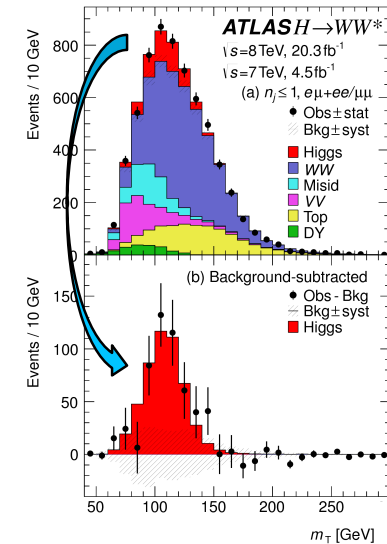



Higgs properties can be inferred from the event rates measured in all the channels.

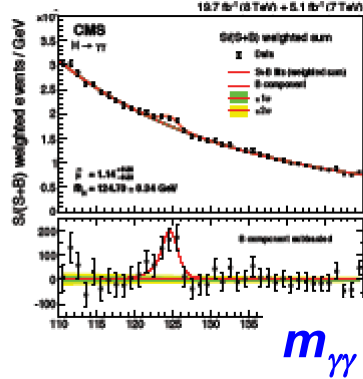

$\gamma\gamma$

$N_{\text{sig}} \approx 200-500$
 $N_{\text{bkg}} \approx 5000$
 $5.2-5.6\sigma$ observed

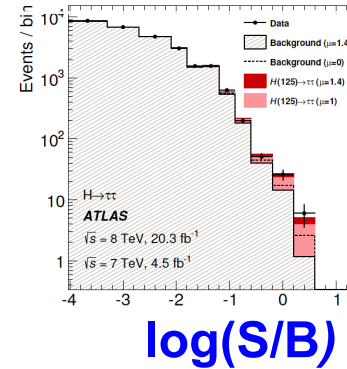

$\tau\tau$

$N_{\text{sig}} \approx 400-650$
 $N_{\text{bkg}} \approx \text{huge}$
 $3.8-4.5\sigma$ observed

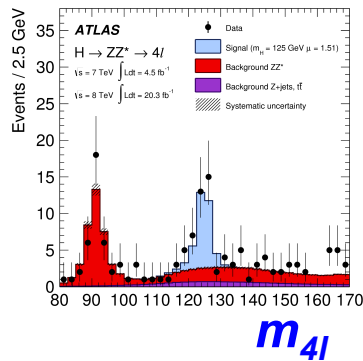

ZZ

$N_{\text{sig}} \approx 20$
 $N_{\text{bkg}} \approx 20$
 $6.5-8.1\sigma$ observed

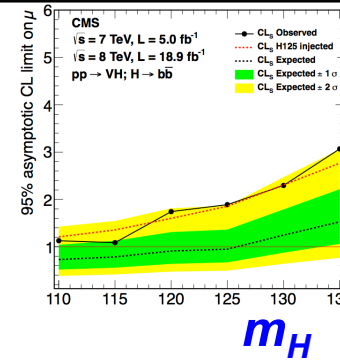

bb

$N_{\text{sig}} \approx 60-100$
 $N_{\text{bkg}} \approx \text{huge}$
 $1.4-2.1\sigma$ observed

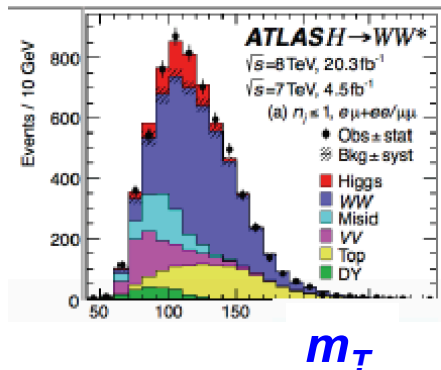

WW

$N_{\text{sig}} \approx 500$
 $N_{\text{bkg}} \approx 7000$
 $4.7-6.5\sigma$ observed

Rare decays: $\mu\mu, Z\gamma, \dots$



Luminosity (25 fb^{-1}) * cross-section (20 pb) = **0.5 M Higgs per experiment!!**
Only one in $\sim 10^{10}$ events contains a Higgs boson.

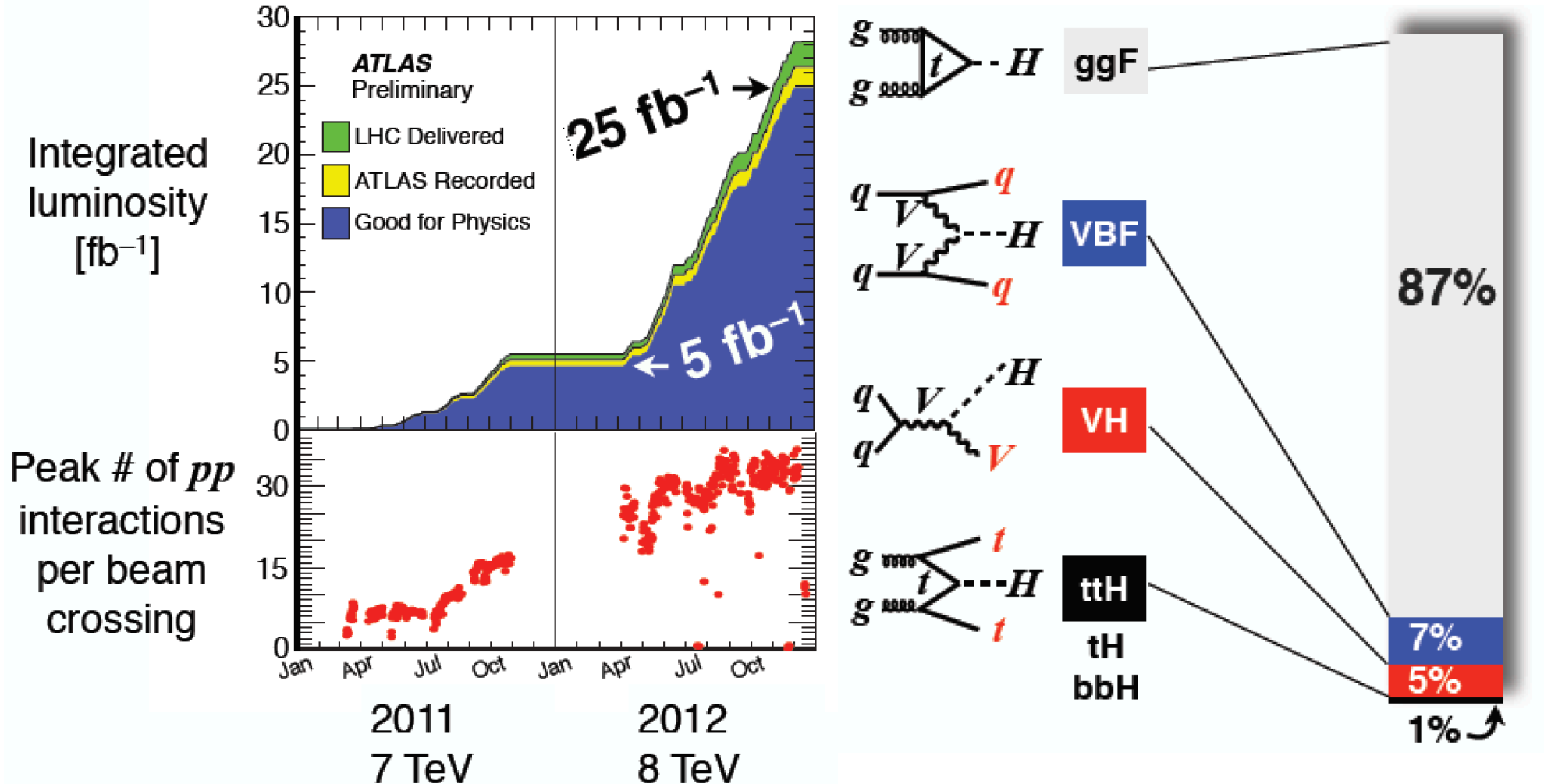



Motivation for top-Higgs Yukawa coupling measurement

- After the discovery of the Higgs boson ($m_H \sim 125.6$ GeV), the focus is on the precise measurement of its properties, in particular couplings to fermions and gauge bosons.

- The top quark is the most strongly-coupled SM particle to the Higgs boson.

For $m_t = 173.34 \pm 0.76$ GeV $\rightarrow \lambda_t = 2m_t/v = 0.996 \pm 0.004$

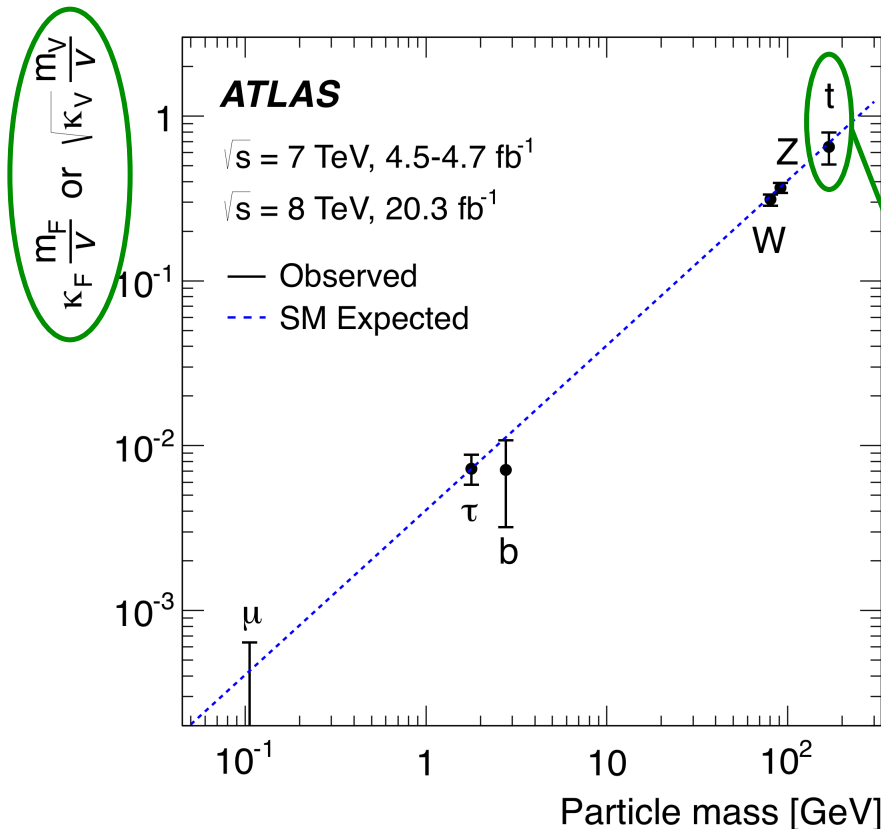

\rightarrow May either play a key role in EWSB, or serve as a window to New Physics related to EWSB which might be preferentially coupled to it.

$H \rightarrow tt$ kinematically forbidden for $m_H = 125$ GeV

- **Indirect constraints** on the top-Higgs Yukawa coupling can be extracted from channels involving the ggH and $H\gamma\gamma$ vertices (assumes no new particles in loops).

- **ttH production mode allows for direct measurement of top Yukawa coupling**
→ allows probing for New Physics contributions in the ggH and $H\gamma\gamma$ vertices.

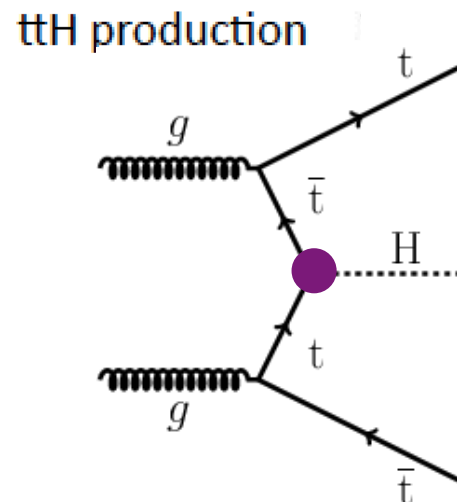
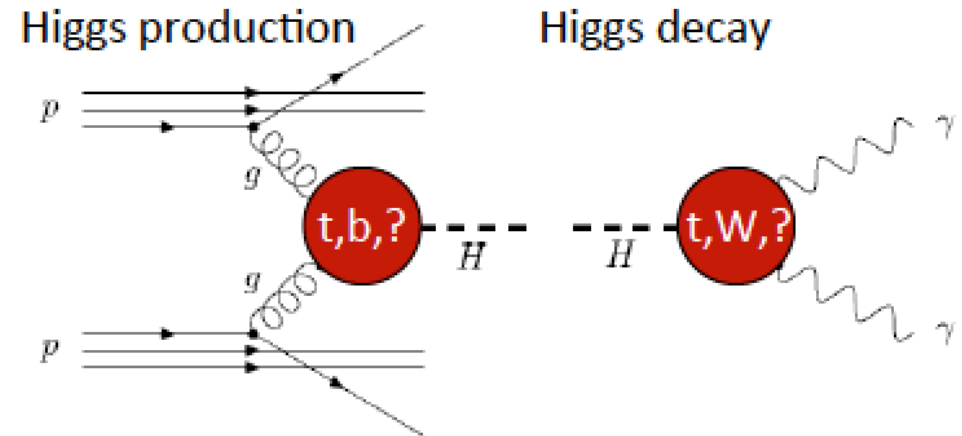

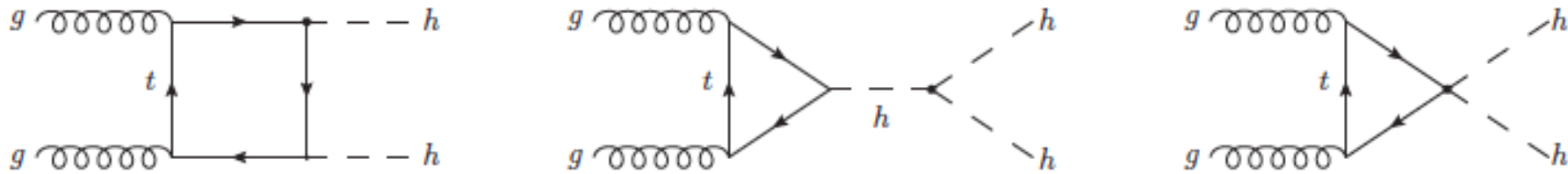

- Similarly, model-independent measurements of the Higgs self-coupling will require precise knowledge of the top-Higgs interactions.
- Higher-dimension operators that involve the top and Higgs fields:
 - are little tested so far, and
 - are particularly sensitive to New Physics associated with EWSB.
- Effective top-Higgs Yukawa coupling can deviate from SM prediction due to contributions from dimension-6 operators.

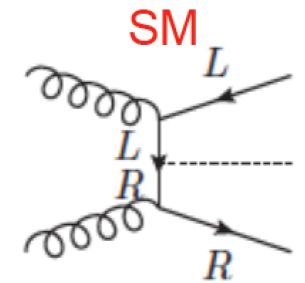

Example: $\sigma(ttH)$ at $\sqrt{s}=14$ TeV:

$$\begin{aligned}
 \frac{\sigma(pp \rightarrow t\bar{t}h)}{\text{fb}} &= 611_{-110}^{+92} + [457_{-91}^{+127} \Re c_{hg} - 49_{-10}^{+15} c_G \\
 &+ 147_{-32}^{+55} c_{HG} - 67_{-16}^{+23} c_y] \left(\frac{\text{TeV}}{\Lambda}\right)^2 \\
 &+ [543_{-123}^{+143} (\Re c_{hg})^2 + 1132_{-232}^{+323} c_G^2 \\
 &+ 85.5_{-21}^{+73} c_{HG}^2 + 2_{-0.5}^{+0.7} c_y^2 \\
 &+ 233_{-144}^{+81} \Re c_{hg} c_{HG} - 50_{-14}^{+16} \Re c_{hg} c_y \\
 &- 3.2_{-8}^{+8} \Re c_{Hy} c_{HG} - 1.2_{-8}^{+8} c_H c_{HG}] \left(\frac{\text{TeV}}{\Lambda}\right)^4
 \end{aligned}$$

Complementary to $\sigma(gg \rightarrow H)$ and $\sigma(tt)$ measurements, which are sensitive to a different combination of operators.



Search for $t\bar{t}H$ in ATLAS





Standard Model Total Production Cross Section Measurements Status: July 2014

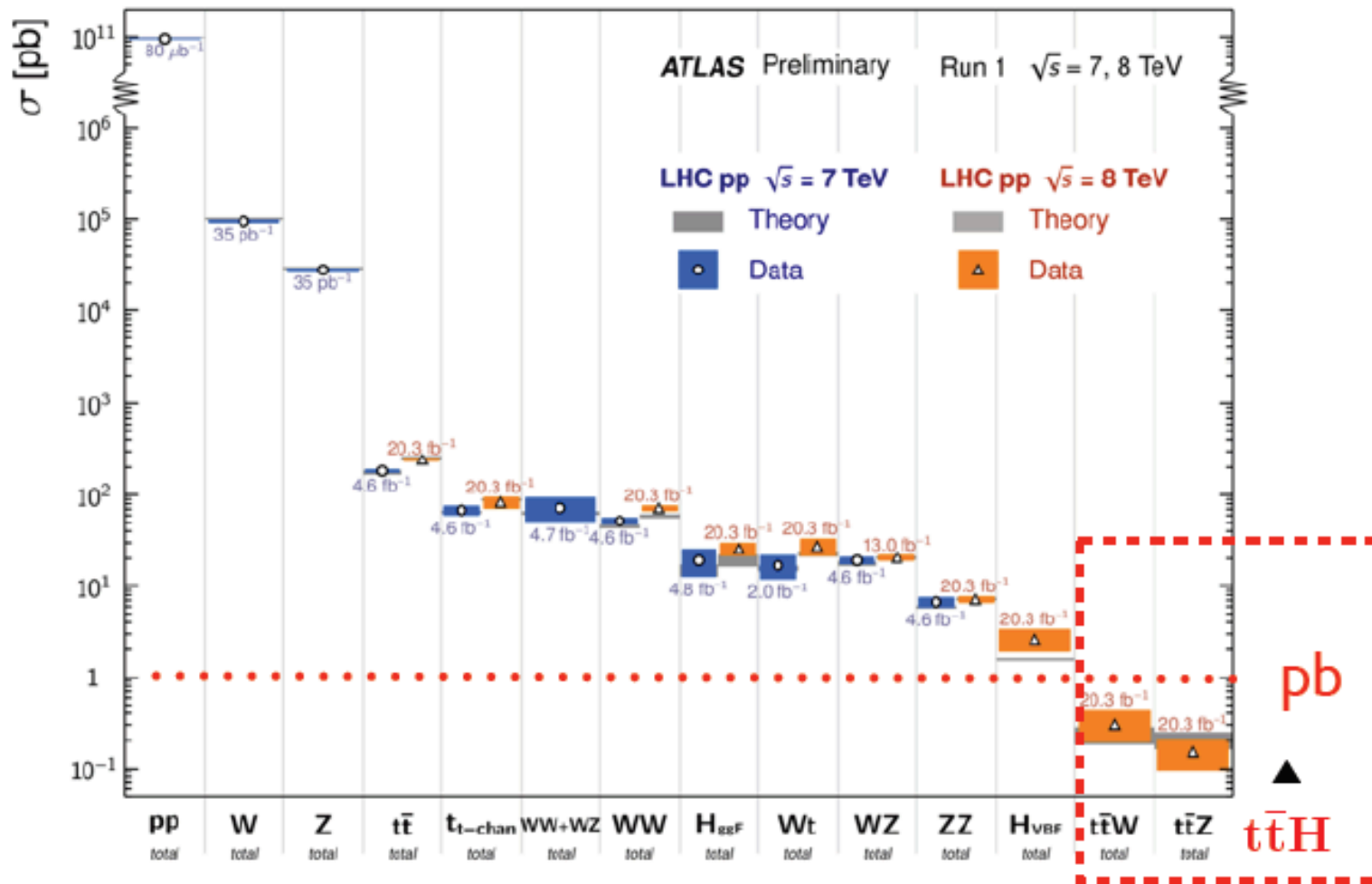

- $\sigma_{\text{NLO}}(t\bar{t}H) \sim 0.13 \text{ pb}$ at 8 TeV \rightarrow ~ 2600 events in 20 fb^{-1}
- main backgrounds: $t\bar{t}+X$, 2000 times higher cross section
- complex final state due to $t\bar{t}$ signature

Virtues:

Many possible final states to consider!

Need to find the best combinations of top and Higgs decay modes to isolate the signal.

Several channels are defined depending on the final signature

→ distinctive final states with high jet/b-tag multiplicity

→ different analysis regions with very different strategy

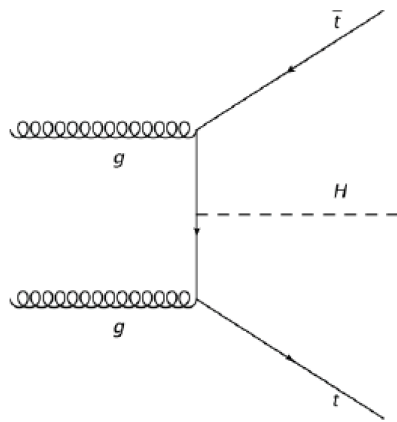

Top Pair Branching Fractions

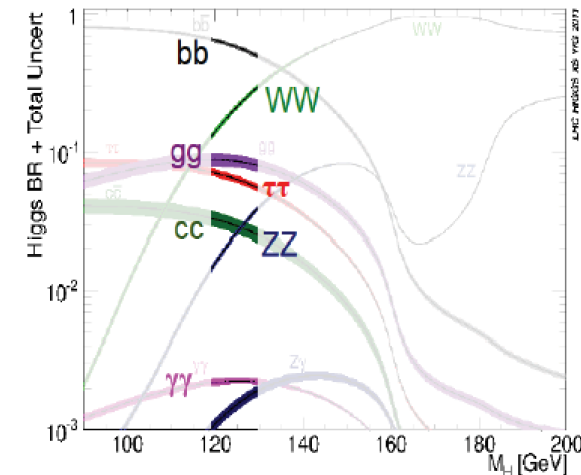
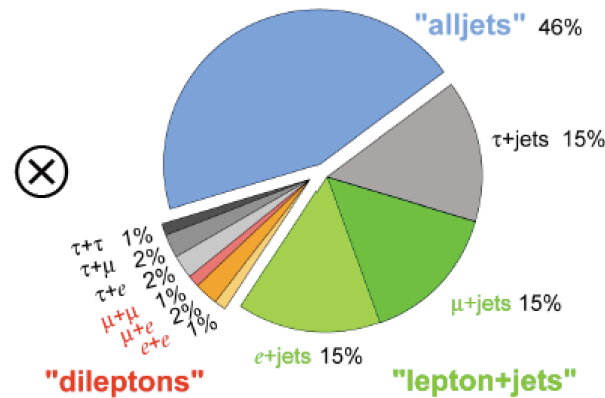

Challenges:

- low production cross section
- a priori many handles against backgrounds!

$H \rightarrow b\bar{b}$ (BR=58%)

dominant mode but large background

$H \rightarrow WW, ZZ, \tau\tau$
(BR=30%)

multilepton final state

$H \rightarrow \gamma\gamma$ (BR<0.23%)

tiny but clean signature

Search for $ttH(H \rightarrow bb)$ in ATLAS

Eur. Phys. J. C (2015) 75:349

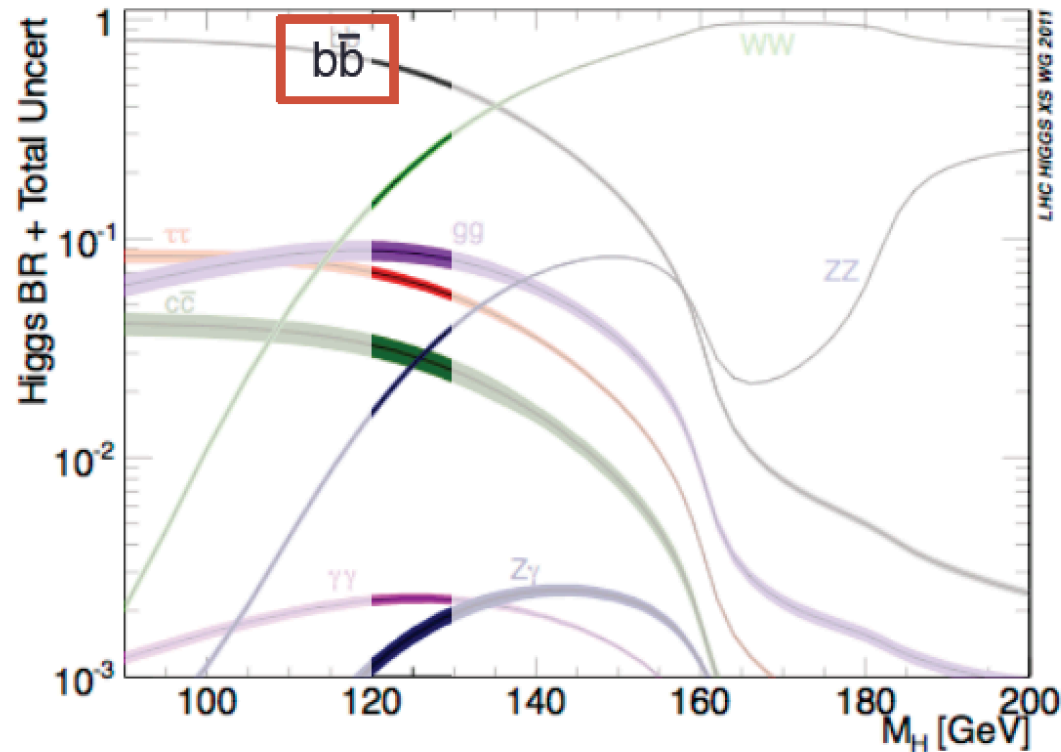

Top Pair Branching Fractions

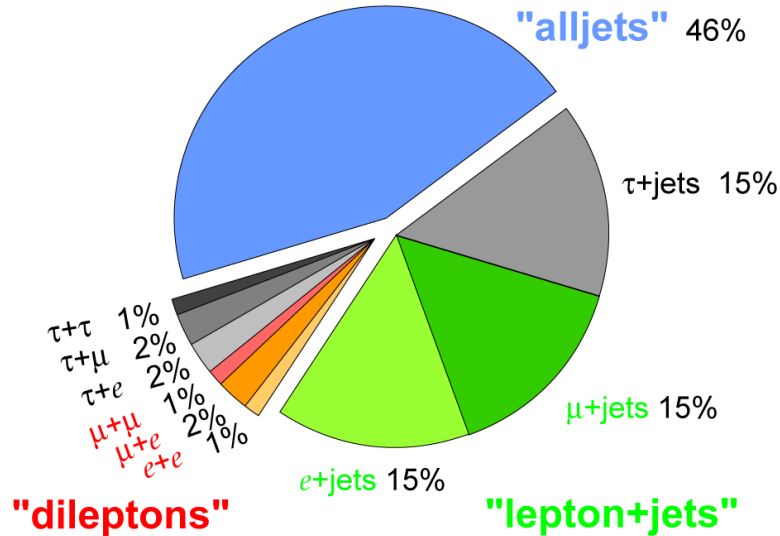

ttH Signal

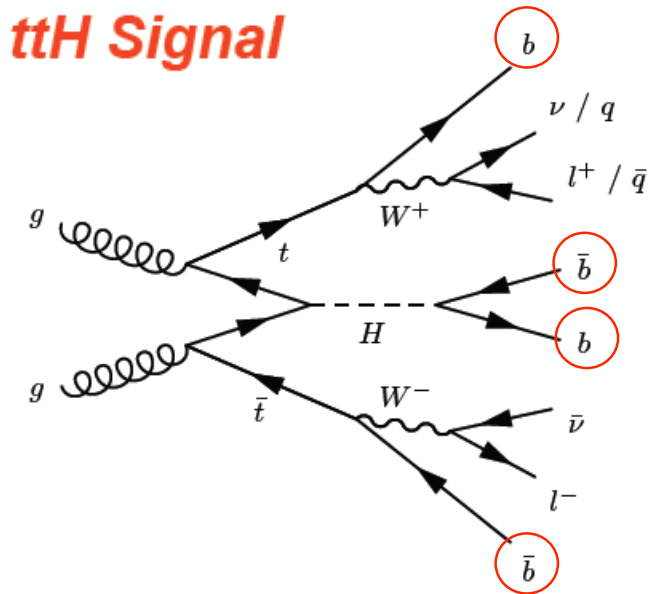

→ focus on the lepton+jets and dilepton channels

▶ Single lepton:

Final state: 1 charged lepton, 6 jets and 4 b-jets

Selection: exactly 1 e/μ and ≥ 4 jets being ≥ 2 b-tagged

▶ Dilepton:

Final state: 2 opposite-sign leptons, 4 jets and 4 b-jets

Selection: exactly 2 leptons (e/μ) with OS and ≥ 2 b-jets

- very difficult signature modelling

- tt +jets ($tt+bb$) background understanding is crucial

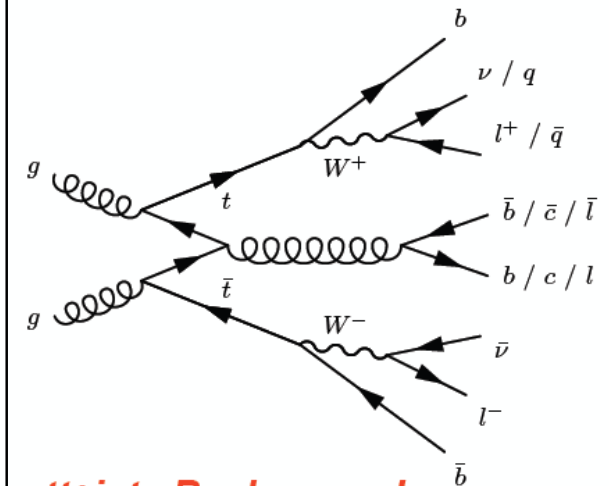

tt +jets Background

ttH ($H \rightarrow bb$) signal produces 1 or 2 leptons and 6 or 4 jets, 4 of them b -jets

- Very challenging final state affected by large systematics:
 - tt+jets, tt+heavy flavour modelling, b -tagging, JES
- Categorize events according to the # jets and b -jets \rightarrow **control** and **signal** regions
- Build **multivariate discriminant** in signal-enriched regions

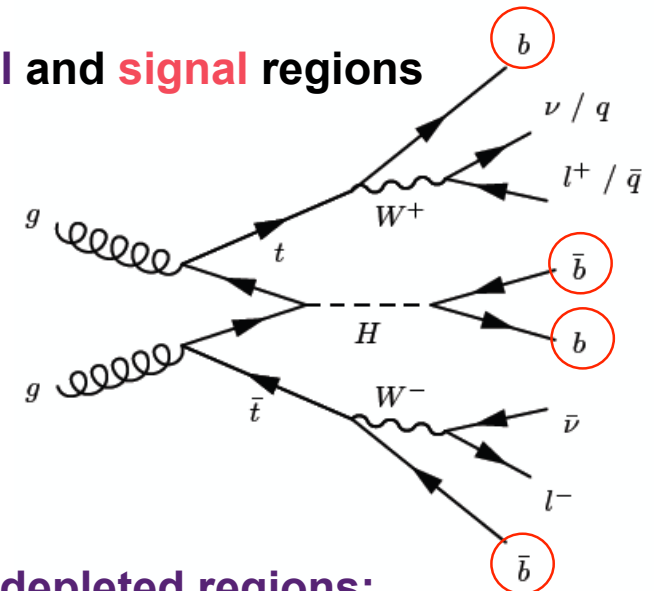

# jets	Single lepton			
	# b-jets	2 b -tags	3 b -tags	≥ 4 b -tags
4 jets		H_T^{had}	H_T^{had}	H_T^{had}
5 jets		H_T^{had}	NN	NN
≥ 6 jets		H_T^{had}	NN	NN

# jets	Dilepton			
	# b-jets	2 b -tags	3 b -tags	≥ 4 b -tags
2 jets		H_T		
3 jets		H_T	NN	
≥ 4 jets		H_T	NN	NN

- **Signal-depleted regions:**

use $H_T^{had} = \text{sum } p_T$ of jets for single lepton
 $H_T = \text{sum } p_T$ of jets and leptons for dilepton

- **Region with 5 jets and 3 b -jets:**

use neural networks (NN) trained to separate tt+bb/cc from tt+light jets

- **Signal-rich regions:**

use NN trained to separate ttH for tt+jets in each region

$t\bar{t}H$ ($H \rightarrow b\bar{b}$) signal produces 1 or 2 leptons and 6 or 4 jets, 4 of them b-jets

- Very challenging final state affected by large systematics:
 $t\bar{t}$ +jets, $t\bar{t}$ +heavy flavour modelling, b -tagging, JES
- Categorize events according to the # jets and b-jets \rightarrow **control** and **signal** regions
- Build **multivariate discriminant** in signal-enriched regions
- Signal-depleted channels play a key role constraining systematic uncertainties
- Analysis relies on a profiled likelihood fit, in order to constrain in-situ the leading systematics

Background composition

Single lepton

high statistics,
constraint on
overall $t\bar{t}$
normalisation
and modelling

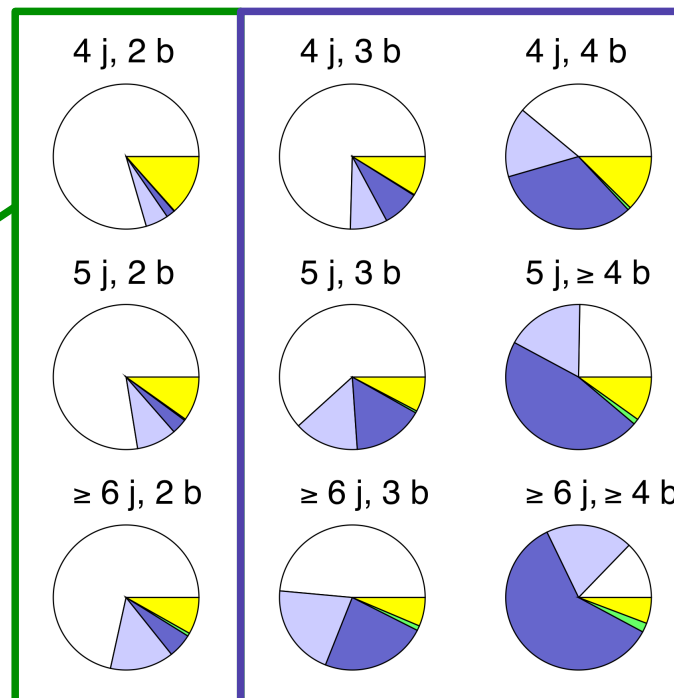

ATLAS Simulation

$m_H = 125$ GeV

$\sqrt{s} = 8$ TeV

$t\bar{t}$ +light

$t\bar{t}$ + $c\bar{c}$

$t\bar{t}$ + $b\bar{b}$

$t\bar{t}$ +V

non- $t\bar{t}$

constraint uncertainties on
 $t\bar{t}b\bar{b}$ and $t\bar{t}c\bar{c}$ normalisations



ttH signal: modelling at NLO, PowHel+Pythia8

Backgrounds:

- Modelling of tt+jets and tt+heavy flavour (HF) backgrounds across different jet and b-tag multiplicities is a critical aspect in this analysis

Powheg+Pythia used as baseline MC

- NLO description of inclusive tt production
 - tt+bb: only parton shower accuracy, but compared to Sherpa NLO prediction
-
- MC prediction for minor backgrounds: V+jets, single top, diboson, tt+V
-
- Multijets (fake lepton): data-driven estimates

ttH signal: modelling at NLO, PowHel+Pythia8

Backgrounds:

- Modelling of tt+jets and tt+heavy flavour (HF) backgrounds across different jet and b-tag multiplicities is a critical aspect in this analysis

Powheg+Pythia used as baseline MC

- NLO description of inclusive tt production
- tt+bb: only parton shower accuracy, but compared to Sherpa NLO prediction

- MC prediction for minor backgrounds: V+jets, single top, diboson, tt+V
- Multijets (fake lepton): data-driven estimates

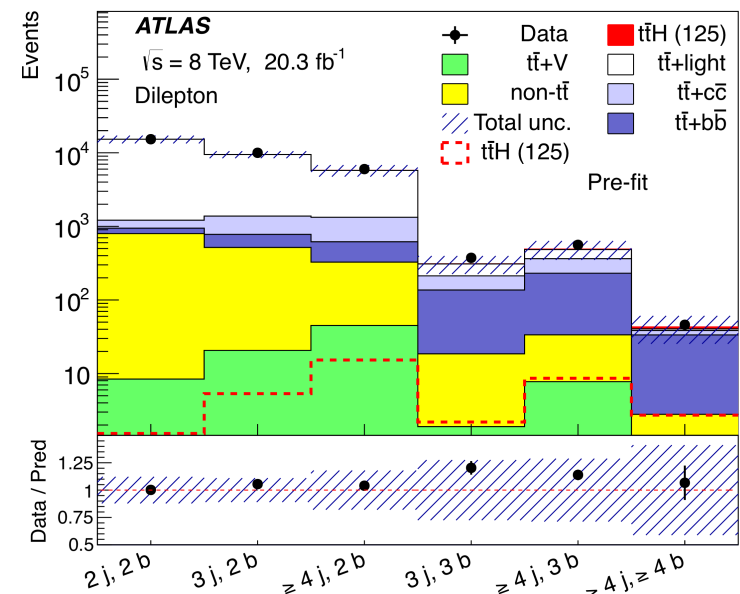
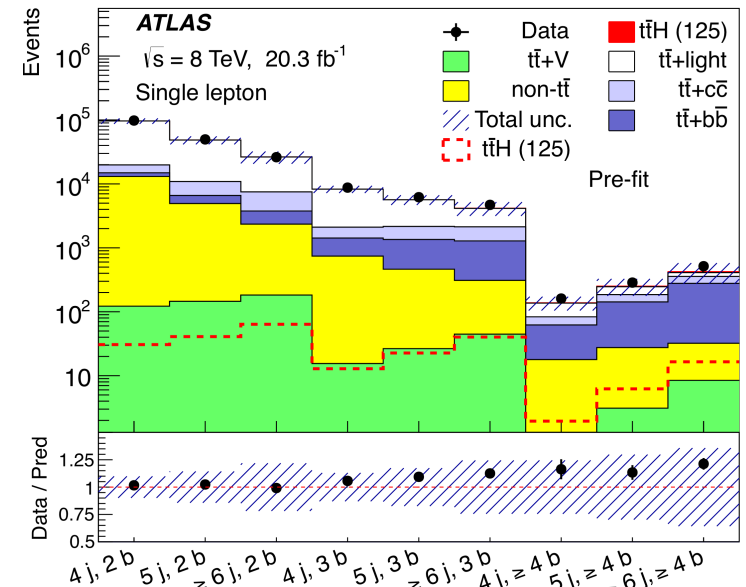

ttH signal: modelling at NLO, PowHel+Pythia8

Backgrounds:

- Modelling of **tt+jets** and **tt+heavy flavour (HF)** backgrounds across different jet and b-tag multiplicities is a critical aspect in this analysis

Powheg+Pythia used as baseline MC

- NLO description of inclusive tt production
- tt+bb: only parton shower accuracy, but compared to Sherpa NLO prediction
- **tt+jets: corrections to MC derived from differential cross section measurement**

- MC prediction for minor backgrounds: V+jets, single top, diboson, tt+V
- Multijets (fake lepton): data-driven estimates

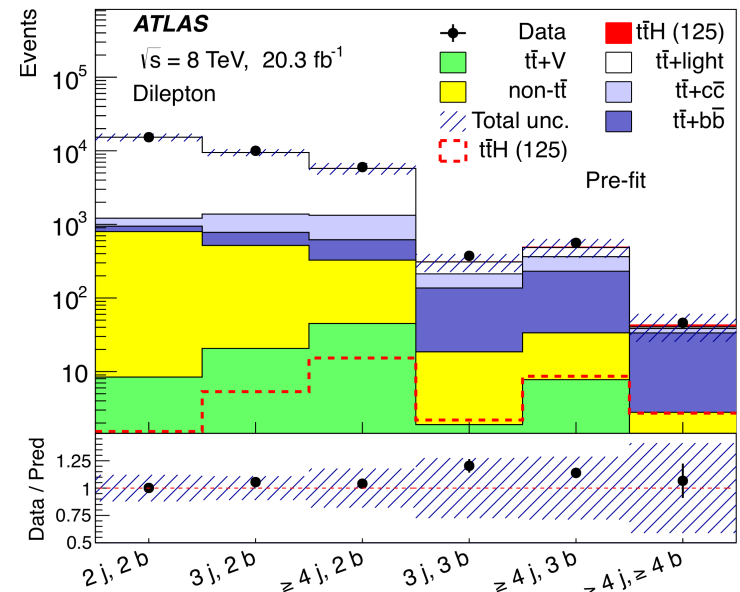
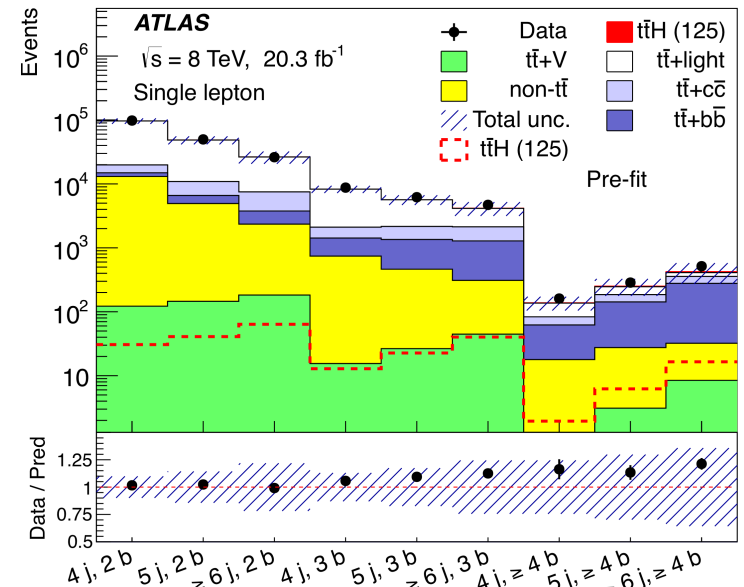



- In Run1, an inclusive tt+jets sample simulated with at NLO accuracy was used.
- Enough statistics in data to validate the modelling: differential cross-section measurement at 7 TeV show that **Powheg+Pythia**, with the settings used, does not match the data.
- In particular, top p_T and ttbar system p_T distributions show that **data is softer than MC**. To correct for this, two reweightings were derived: top p_T and ttbar p_T spectra.

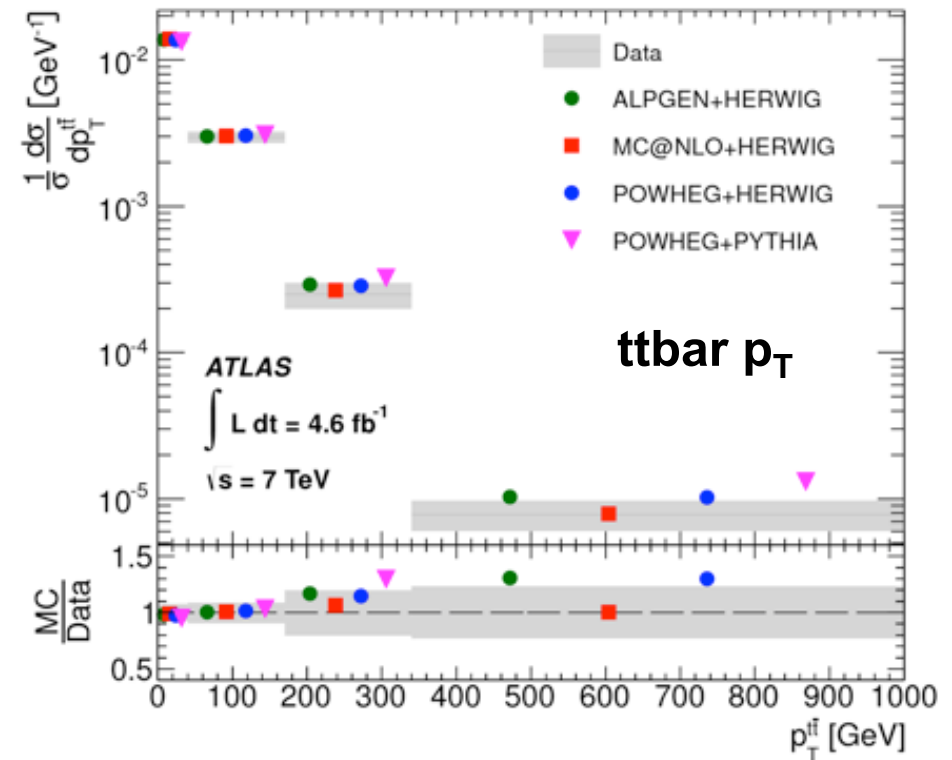
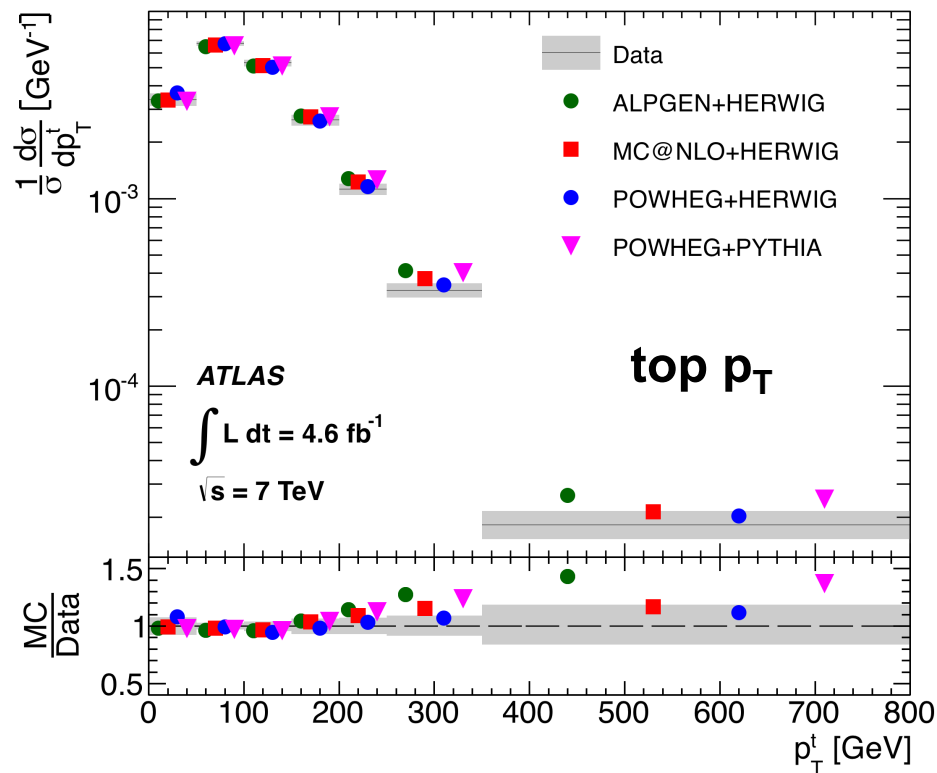

ttbar p_T reweighting in ATLAS mainly affects # of jets

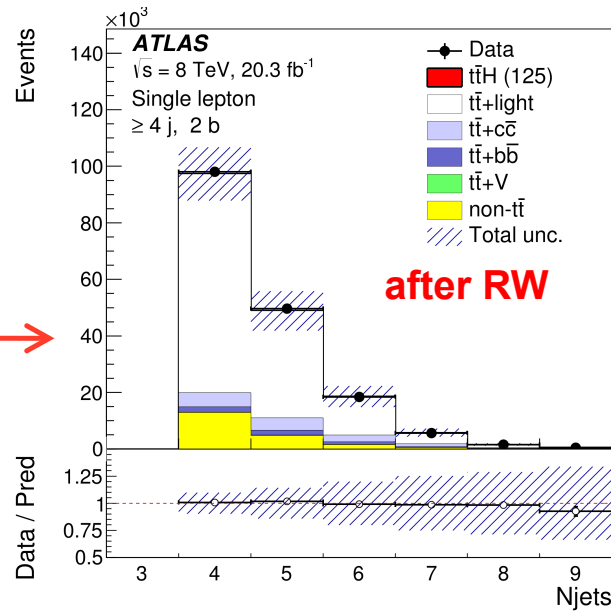
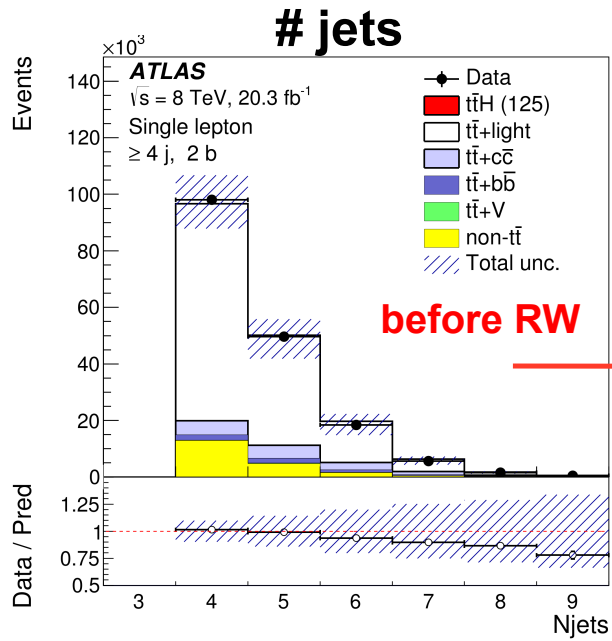

- Clear improvement after the reweighting.
- Assign uncertainties from the measurement to this correction.

H_T
(scalar sum p_T of all jets)

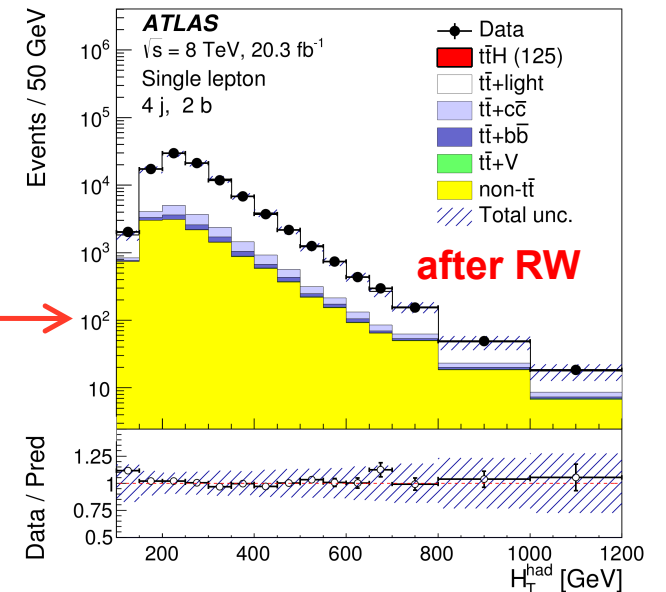
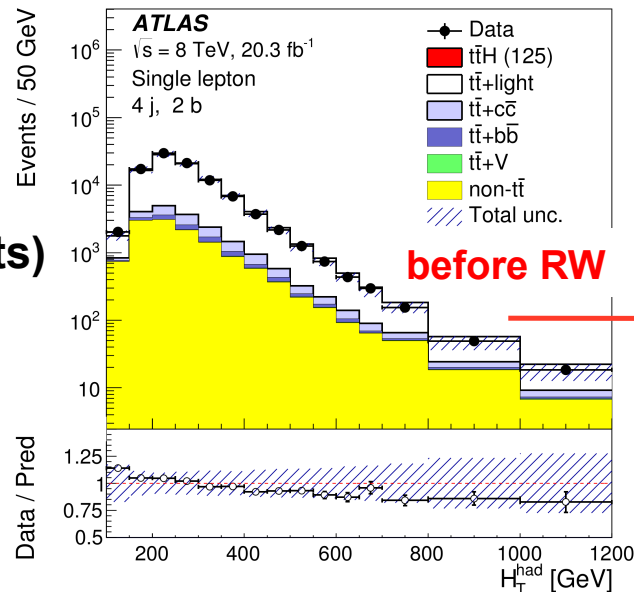

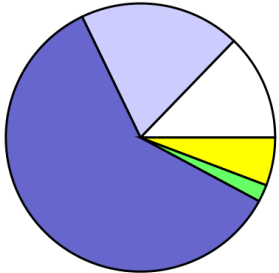
$\geq 6 j, \geq 4 b$ **tt+bb: main and irreducible background to ttH(H→bb)**

- pure QCD process with $\sigma \sim 5$ pb (ttH signal $\sigma \sim 0.13$ pb) at 8 TeV
- very difficult to model (no data control regions - rely purely on MC)
- leading systematics due to modelling of tt+bb
- definitions of tt+bb different between two collaborations

tt+bb is pure parton shower in Powheg+Pythia

→ need to assign syst. unc. from comparisons with (new) dedicated NLO ttbb samples

* normalization: 50% unc. (constrained down $\sim 20\%$ in the fit)

* shape:

1- compare the relative contributions of diff. categories of tt+heavy flavour

2- compare kinematic dist. → re-weight events to match kinematics of SherpaOL NLO tt+bb

The modelling of tt+bb background plays a key role in this search. Therefore, the implementation of the latest theoretical developments is crucial.

In close collaboration with theorists:

- ✓ Studies ongoing for tt+bb NLO for 4F vs 5F scheme
- ✓ How to merge with ttbar+jets?
- ✓ Sherpa+OpenLoops NLO 4F tt+bb compared with NLO (Powheg and aMC@NLO_MadGraph5)+PS and Sherpa MEPS@NLO
- ✓ EW corrections might be significant



- tt+heavy flavour (HF) classification based on truth jets, no matching to reconstructed jets
 - truth jets are built from stable particles, excluding μ and ν (anti- k_T algorithm $R=0.4$, $p_T > 15$ GeV)
- find particle jets containing a B/C hadron with $p_T > 5$ GeV not originated from top decays
- count number of B/C hadrons inside the jet, and classify the events
 - resolved “**tt+Xb**”: the event contains X HF jets, each of them contains exactly 1 HF hadron
 - unresolved/merged $g \rightarrow bb$ splitting “**tt+XB**”: each jet contains more than 1 HF hadron

• allows comparison among generators

• assign **ttbb modelling systematics at NLO**

- factorisation scale up/down, different functional forms for the factorisation, renormalisation and resummation scales

- PDF variations (MSTW, NNPDF), shower recoil scheme variation

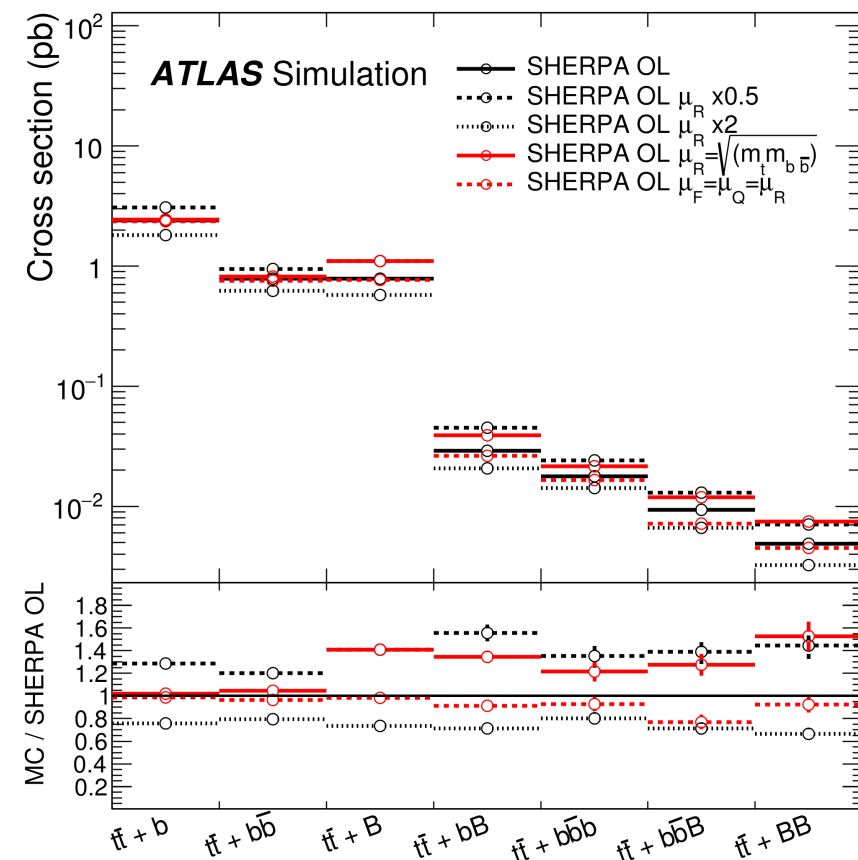



ATLAS Simulation
 $\sqrt{s} = 8 \text{ TeV}, 20.3 \text{ fb}^{-1}$

Single lepton
 $m_H = 125 \text{ GeV}$

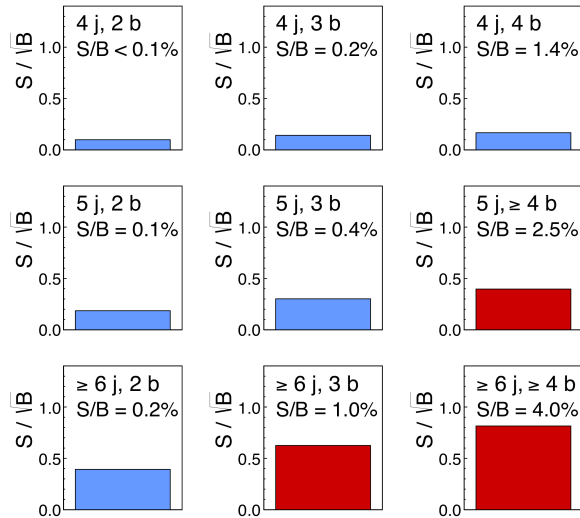

NN are trained using several types of variables:

- **object kinematics** (p_T^{jet}),
- **object pair properties** ($\Delta\eta_{jj}^{\text{max}\Delta\eta}$)
- **global event variables (centrality)**
- **matrix element method** (for single lepton ch.):
 - Neyman-Pearson likelihood ratio $D1$
 - summed signal log-likelihood SSLL

$$D1 = \frac{\mathcal{L}_{t\bar{t}H}^{\text{evt}}}{\mathcal{L}_{t\bar{t}H}^{\text{evt}} + \alpha \cdot \mathcal{L}_{t\bar{t}b\bar{b}}^{\text{evt}}}$$

Variable	Definition	NN rank		
		$\geq 6j, \geq 4b$	$\geq 6j, 3b$	$5j, \geq 4b$
$D1$	Neyman–Pearson MEM discriminant (Eq. (4))	1	10	-
Centrality	Scalar sum of the p_T divided by sum of the E for all jets and the lepton	2	2	1
$p_T^{\text{jet}5}$	p_T of the fifth leading jet	3	7	-
$H1$	Second Fox–Wolfram moment computed using all jets and the lepton	4	3	2
$\Delta R_{bb}^{\text{avg}}$	Average ΔR for all b -tagged jet pairs	5	6	5
SSLL	Logarithm of the summed signal likelihoods (Eq. (2))	6	4	-
$m_{bb}^{\text{min}} \Delta R$	Mass of the combination of the two b -tagged jets with the smallest ΔR	7	12	4

...

- The Matrix Element Method is used to compute the likelihood for an event to be originated from a certain theoretical hypothesis.
- Compute the likelihood respect to the **ttH or ttbb hypothesis**

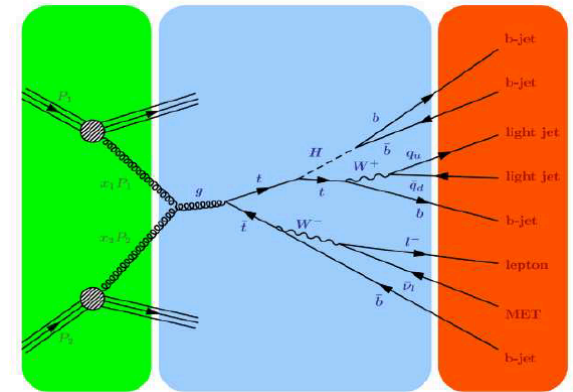

$$\underbrace{P_{\vec{x}_{\text{Detector}}}(m_H)}_{\text{probability}} = \frac{1}{\underbrace{\sigma_{ttH}(m_H)}_{\text{normalization}}} \int \underbrace{dp_{g1} dp_{g2} f(p_{g1}) f(p_{g2})}_{\text{parton density function}} \underbrace{d\sigma_{ttH}(\vec{x}_{\text{Parton}}, m_H)}_{\text{differential cross section}} \underbrace{W(\vec{x}_{\text{Parton}}, \vec{x}_{\text{Detector}})}_{\text{transfer functions}}$$

- PDFs account for production mechanism (CTEQ6L1 set)
- Differential cross section proportional to $|M|^2$, consider only LO ME from MadGraph
 - test ttbb and ttH hypothesis (all LO diagrams included: 10 for ttH and 43 for ttbb)
 - full decay to preserve angular correlations
- Transfer functions map detector response to parton level
- VEGAS technique for Integration with O(10%)
- Likelihood ratio of ttH/ttbb hypothesis (D1) is the most discriminating variable against ttbb in 6j4b
- Sum of likelihood under signal hypothesis (SSLL) is discriminating against the rest of the backgrounds

$$D1 = \frac{\mathcal{L}_{ttH}^{\text{evt}}}{\mathcal{L}_{ttH}^{\text{evt}} + \alpha \cdot \mathcal{L}_{ttbb}^{\text{evt}}}$$

- Reduction of assignment permutations using b-tagging:
12(36) invariant perm. in 6j4b (6j3b)
- Choose pair of untagged jets closest to W mass
- Delta function detector response for the objects
eta/phi and lepton 4-momentum
→ 6 jet energies + neutrino p_z
→ solve neutrino p_z imposing W mass
- Reduction of dimensionality: 6 variables
 - bb mass, leading b-jet energy
 - hadronic W mass, leading light-jet energy
 - 2 b-jets from top

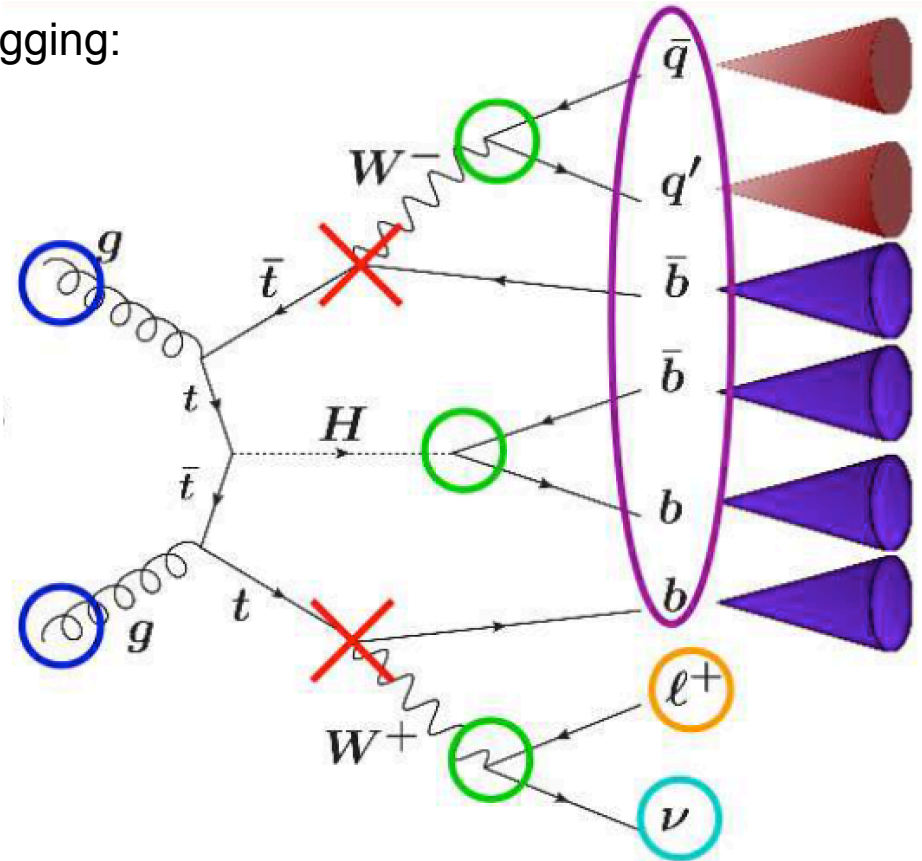

Number of dimensions: $10 \times 4 = 40$

Momentum conservation and initial $p_T=0 \rightarrow -8$

6 jets with known eta, phi and mass $\rightarrow -6 \times 3 = -18$

Lepton with known four momentum (delta-function for detector response) $\rightarrow -4$

Solve p_z neutrino using W mass constrain (NWA for Wlep) $\rightarrow -4$

Total: **6**

- Reduction of assignment permutations using b-tagging:
12(36) invariant perm. in 6j4b (6j3b)
- Phase space alignment (to optimise integration)
transformation to m_W, m_H
- Reduction of dimensionality: 6 integration variables
3 b-quark energies ($E_{btop1}, E_{btop2}, E_{bH1}$)
1 light-quark energy (E_{lq1}),
 $m(W_{had})$ and $m(H)$

• Integration time reduction: 24h \rightarrow 2min/event

Number of events

Nominal sample: 6M

Systematic variations (35): 56 M

\rightarrow 62M events* 2min \sim 2M CPU hours

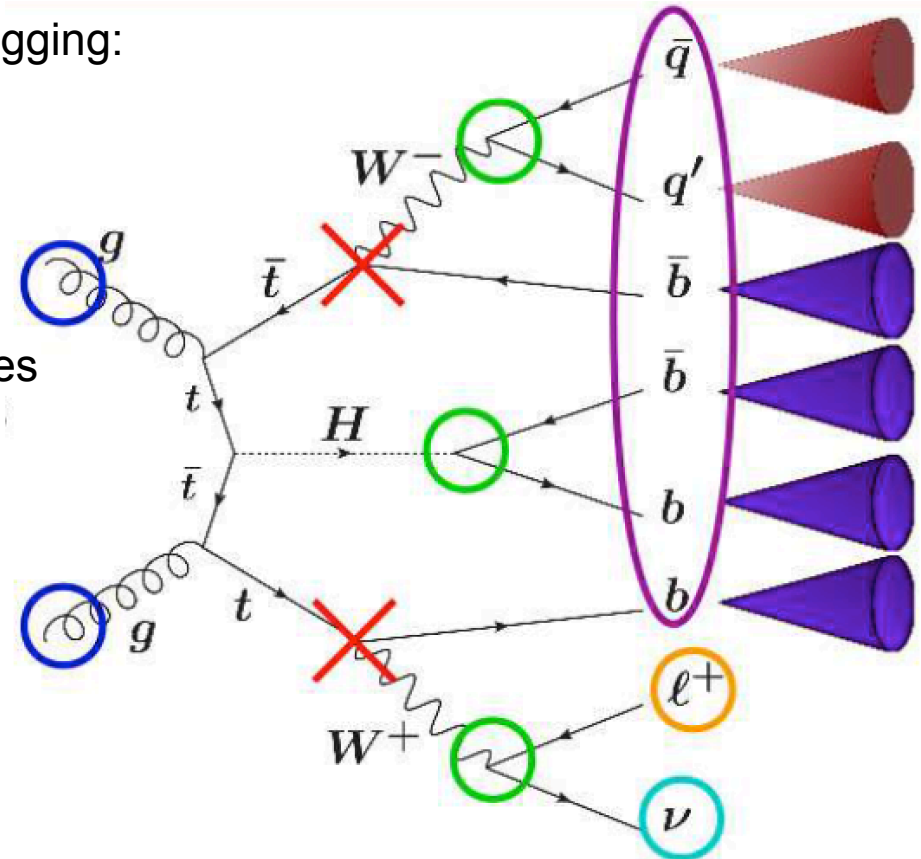

Number of dimensions: $10 \times 4 = 40$

Momentum conservation and initial $p_T=0 \rightarrow -8$

6 jets with known eta, phi and mass $\rightarrow -6 \times 3 = -18$

Lepton with known four momentum (delta-function for detector response) $\rightarrow -4$

Solve p_z neutrino using W mass constrain (NWA for Wlep) $\rightarrow -4$

Total: **6**



ATLAS Simulation
 $\sqrt{s} = 8 \text{ TeV}, 20.3 \text{ fb}^{-1}$

Single lepton

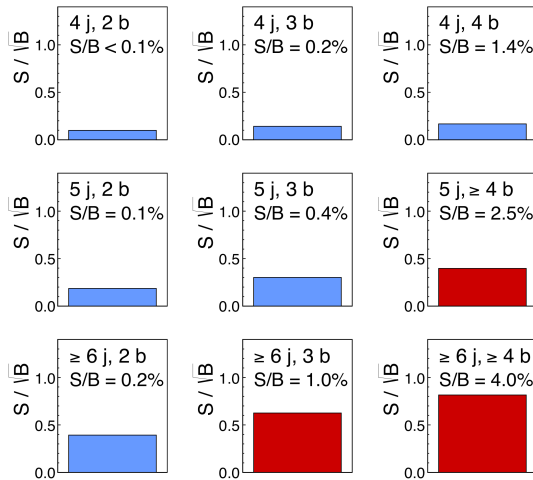

NN are trained using several types of variables:

- object kinematics (p_T^{jet}),
- dijet pairs properties ($\Delta\eta_{jj}^{\text{max}\Delta\eta}$)
- global event variables (centrality)
- matrix element method (for single lepton ch.):
 - Neyman-Pearson likelihood ratio D1
 - summed signal log-likelihood SSLL

$$\text{sep} = \frac{1}{2} \sum_{\text{bins}} \frac{(y_{\text{sig}} - y_{\text{bkg}})^2}{y_{\text{sig}} + y_{\text{bkg}}}$$

Neyman-Pearson likelihood ratio

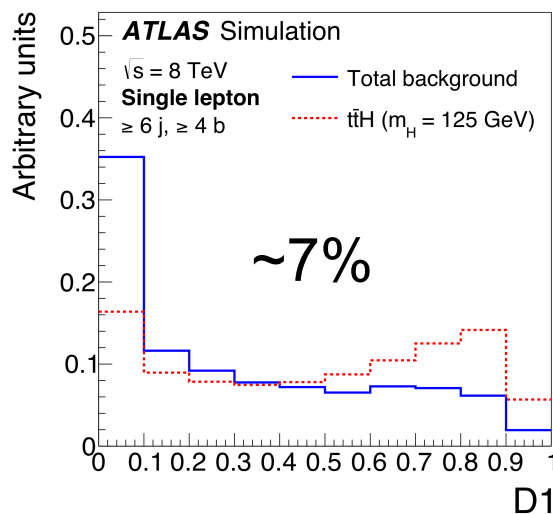

centrality = $\Sigma p_T / \Sigma E$

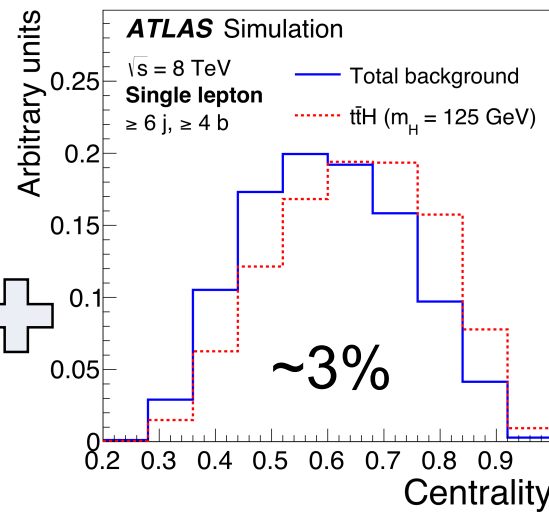

NN output

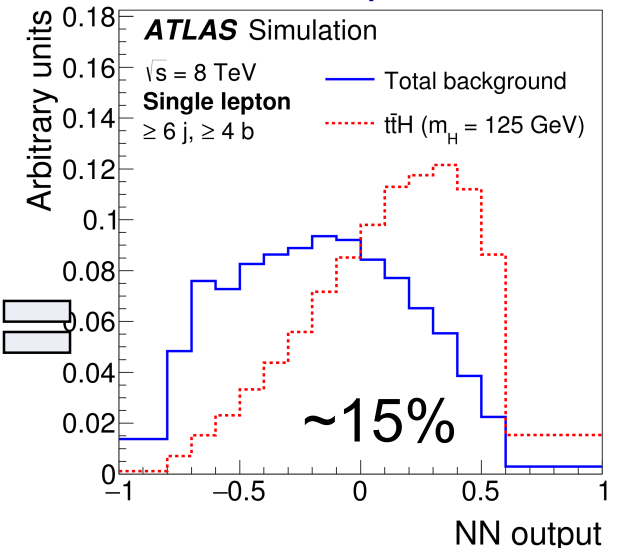



Dilepton

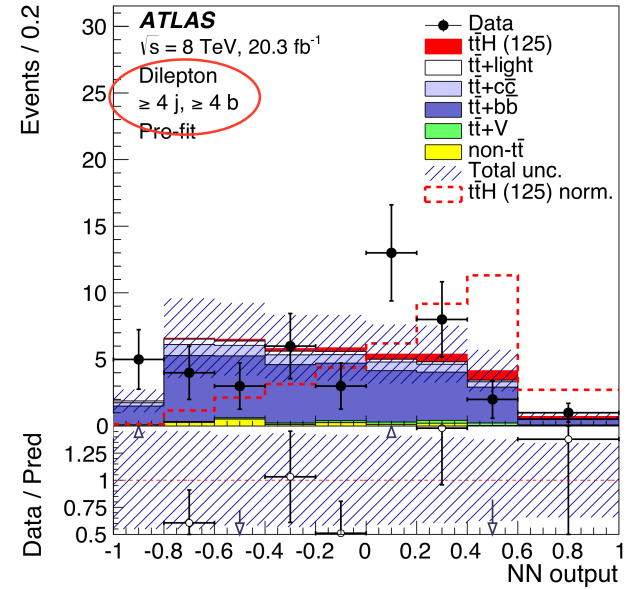
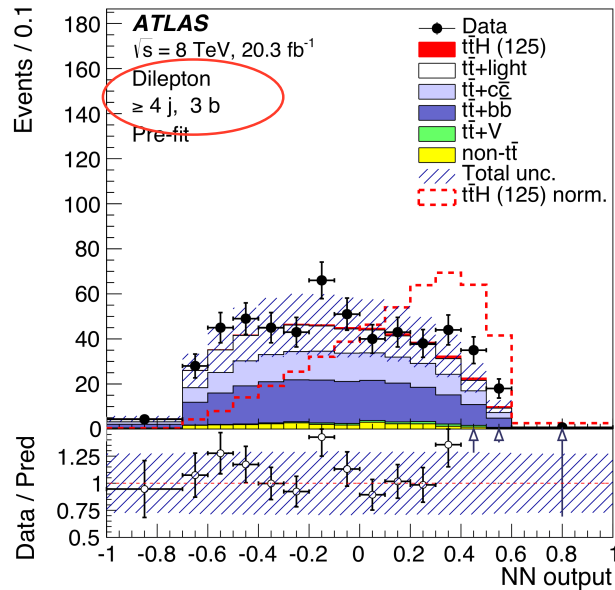

Single lepton

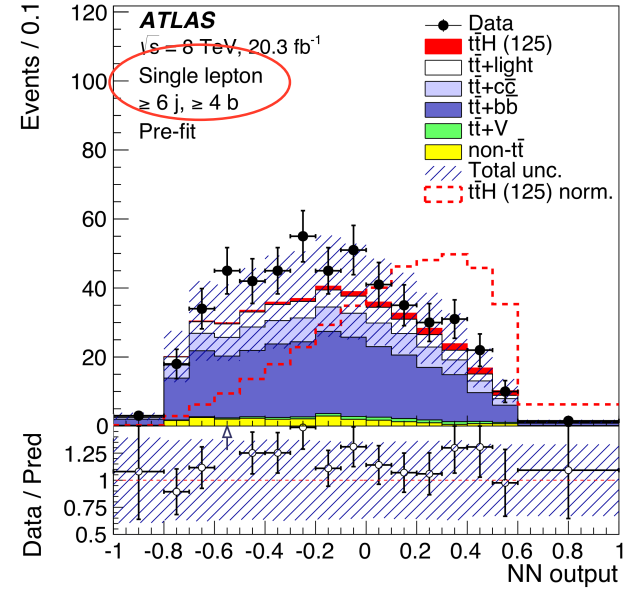
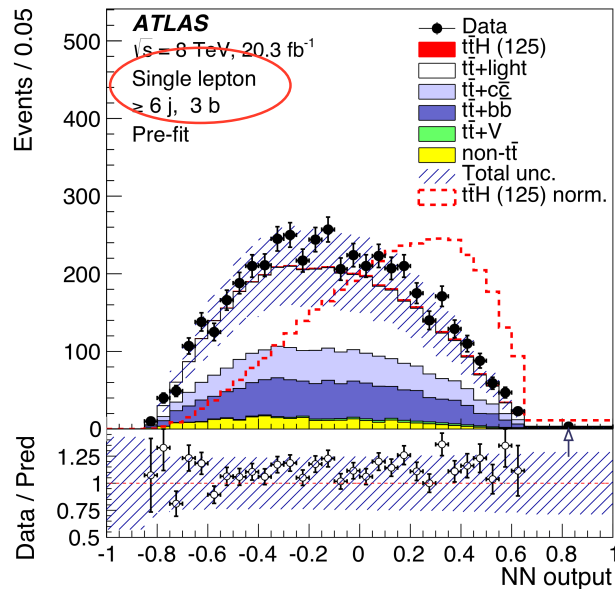

Signal extracted via binned likelihood fit $L(\mu, \theta)$ to all analysis regions under S+B hypothesis

$$L(\mu, \theta) = L_{Pois}(\mu, \theta) \cdot \prod_p \frac{1}{\sqrt{2\pi}} \exp\left(-\frac{\theta_p^2}{2}\right) \cdot \prod_{i,j} \frac{1}{\sqrt{2\pi}\sigma_{\gamma,ij}} \exp\left(-\frac{(\gamma_{ij} - 1)^2}{2\sigma_{\gamma,ij}^2}\right)$$

$$L_{Pois}(\mu) = \prod_j \prod_i^{reg\ bins(j)} \frac{(\mu s_{ij} + b_{ij})^{n_{ij}}}{n_{ij}!} \exp(-(\mu s_{ij} + b_{ij}))$$

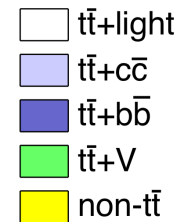

- parameter of interest: signal strength $\mu = \sigma/\sigma_{SM}$
- nuisance parameters θ_p : systematic uncertainties
- nuisance parameters $\sigma_{\gamma,ij}$: MC statistical uncertainty per bin

→ Find the best values for μ and θ_p by minimizing the log L

- obtain fitted uncertainty on μ
- high-statistics control samples can constrain the “a priori” nuisance parameters values:
 - tt modelling - across 2b regions
 - tt+HF - 3b / $\geq 4b$ -tags regions

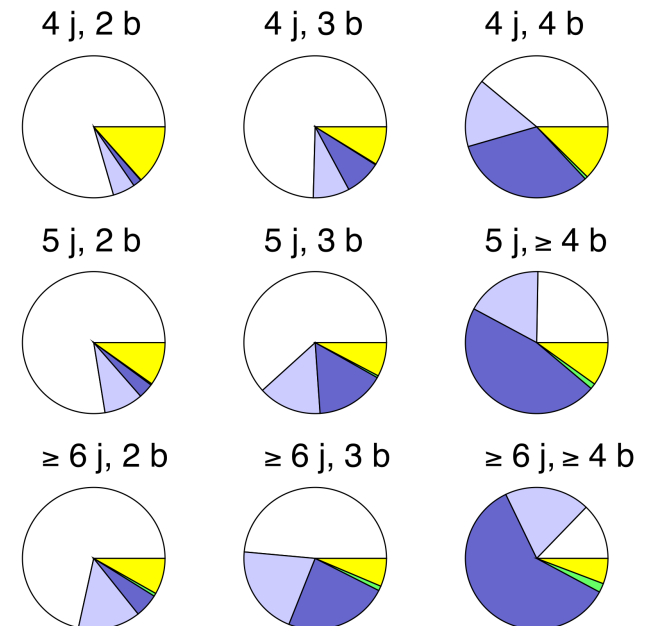

→ Calculate the experimental sensitivity in terms of the significance (i.e. level of disagreement between the data and the background-only hypothesis expressed as Gaussian standard deviations σ)



Systematic uncertainty	Type	Components
Luminosity	N	1
Physics Objects		
Electron	SN	5
Muon	SN	6
Jet energy scale	SN	22
Jet vertex fraction	SN	1
Jet energy resolution	SN	1
Jet reconstruction	SN	1
<i>b</i> -tagging efficiency	SN	6
<i>c</i> -tagging efficiency	SN	4
Light jet-tagging efficiency	SN	12
Background Model		
<i>t</i> \bar{t} cross section	N	1
<i>t</i> \bar{t} modelling: p_T reweighting	SN	9
<i>t</i> \bar{t} modelling: parton shower	SN	3
<i>t</i> \bar{t} +heavy-flavour: normalisation	N	2
<i>t</i> \bar{t} + <i>c</i> \bar{c} : HF reweighting	SN	2
<i>t</i> \bar{t} + <i>c</i> \bar{c} : generator	SN	4
<i>t</i> \bar{t} + <i>b</i> \bar{b} : NLO Shape	SN	8
W+jets normalization	N	3
W p_T reweighting	SN	1
Z+jets normalization	N	3
Z p_T reweighting	SN	1
Multijet normalisation	N	3
Multijet shape	S	2
Single top cross section	N	1
Single top model	SN	1
Diboson+jets normalization	N	3
<i>t</i> \bar{t} V cross section	N	1
<i>t</i> \bar{t} V model	SN	1
Signal Model		
<i>t</i> \bar{t} H scale	SN	2
<i>t</i> \bar{t} H Generator	SN	1
<i>t</i> \bar{t} H hadronization	SN	1
<i>t</i> \bar{t} H PDF	SN	1

- Luminosity (2.8%)

S = shape, N = normalization



Systematic uncertainty	Type	Components
Luminosity	N	1
Physics Objects		
Electron	SN	5
Muon	SN	6
Jet energy scale	SN	22
Jet vertex fraction	SN	1
Jet energy resolution	SN	1
Jet reconstruction	SN	1
<i>b</i> -tagging efficiency	SN	6
<i>c</i> -tagging efficiency	SN	4
Light jet-tagging efficiency	SN	12
Background Model		
<i>t</i> \bar{t} cross section	N	1
<i>t</i> \bar{t} modelling: p_T reweighting	SN	9
<i>t</i> \bar{t} modelling: parton shower	SN	3
<i>t</i> \bar{t} +heavy-flavour: normalisation	N	2
<i>t</i> \bar{t} + <i>c</i> \bar{c} : HF reweighting	SN	2
<i>t</i> \bar{t} + <i>c</i> \bar{c} : generator	SN	4
<i>t</i> \bar{t} + <i>b</i> \bar{b} : NLO Shape	SN	8
W+jets normalization	N	3
W p_T reweighting	SN	1
Z+jets normalization	N	3
Z p_T reweighting	SN	1
Multijet normalisation	N	3
Multijet shape	S	2
Single top cross section	N	1
Single top model	SN	1
Diboson+jets normalization	N	3
<i>t</i> \bar{t} V cross section	N	1
<i>t</i> \bar{t} V model	SN	1
Signal Model		
<i>t</i> \bar{t} H scale	SN	2
<i>t</i> \bar{t} H Generator	SN	1
<i>t</i> \bar{t} H hadronization	SN	1
<i>t</i> \bar{t} H PDF	SN	1

- **Luminosity** (2.8%)
- **Physics objects**
 - leptons (2%)
 - jets: ID, JVF, JER (4%), JES (10%)
 - tagging (5-20%)

S = shape, N = normalization



Systematic uncertainty	Type	Components
Luminosity	N	1
Physics Objects		
Electron	SN	5
Muon	SN	6
Jet energy scale	SN	22
Jet vertex fraction	SN	1
Jet energy resolution	SN	1
Jet reconstruction	SN	1
<i>b</i> -tagging efficiency	SN	6
<i>c</i> -tagging efficiency	SN	4
Light jet-tagging efficiency	SN	12
Background Model		
<i>t</i> \bar{t} cross section	N	1
<i>t</i> \bar{t} modelling: p_T reweighting	SN	9
<i>t</i> \bar{t} modelling: parton shower	SN	3
<i>t</i> \bar{t} +heavy-flavour: normalisation	N	2
<i>t</i> \bar{t} + <i>c</i> \bar{c} : HF reweighting	SN	2
<i>t</i> \bar{t} + <i>c</i> \bar{c} : generator	SN	4
<i>t</i> \bar{t} + <i>b</i> \bar{b} : NLO Shape	SN	8
W+jets normalization	N	3
W p_T reweighting	SN	1
Z+jets normalization	N	3
Z p_T reweighting	SN	1
Multijet normalisation	N	3
Multijet shape	S	2
Single top cross section	N	1
Single top model	SN	1
Diboson+jets normalization	N	3
<i>t</i> \bar{t} V cross section	N	1
<i>t</i> \bar{t} V model	SN	1
Signal Model		
<i>t</i> \bar{t} H scale	SN	2
<i>t</i> \bar{t} H Generator	SN	1
<i>t</i> \bar{t} H hadronization	SN	1
<i>t</i> \bar{t} H PDF	SN	1

- **Luminosity** (2.8%)
- **Physics objects**
 - leptons (2%)
 - jets: ID, JVF, JER (4%), JES (10%)
 - tagging (5-20%)
- **Background model**
 - tt+jets
 - cross-section (6%)
 - parton shower model (10-15%)
 - reweighting to data (6%)
 - tt+bb/cc normalisation (50%)
 - tt+bb/cc modelling
 - small backgrounds

S = shape, N = normalization



Systematic uncertainty	Type	Components
Luminosity	N	1
Physics Objects		
Electron	SN	5
Muon	SN	6
Jet energy scale	SN	22
Jet vertex fraction	SN	1
Jet energy resolution	SN	1
Jet reconstruction	SN	1
<i>b</i> -tagging efficiency	SN	6
<i>c</i> -tagging efficiency	SN	4
Light jet-tagging efficiency	SN	12
Background Model		
<i>t</i> \bar{t} cross section	N	1
<i>t</i> \bar{t} modelling: p_T reweighting	SN	9
<i>t</i> \bar{t} modelling: parton shower	SN	3
<i>t</i> \bar{t} +heavy-flavour: normalisation	N	2
<i>t</i> \bar{t} + <i>c</i> \bar{c} : HF reweighting	SN	2
<i>t</i> \bar{t} + <i>c</i> \bar{c} : generator	SN	4
<i>t</i> \bar{t} + <i>b</i> \bar{b} : NLO Shape	SN	8
W+jets normalization	N	3
W p_T reweighting	SN	1
Z+jets normalization	N	3
Z p_T reweighting	SN	1
Multijet normalisation	N	3
Multijet shape	S	2
Single top cross section	N	1
Single top model	SN	1
Diboson+jets normalization	N	3
<i>t</i> \bar{t} V cross section	N	1
<i>t</i> \bar{t} V model	SN	1
Signal Model		
<i>t</i> \bar{t} H scale	SN	2
<i>t</i> \bar{t} H Generator	SN	1
<i>t</i> \bar{t} H hadronization	SN	1
<i>t</i> \bar{t} H PDF	SN	1

- **Luminosity** (2.8%)
- **Physics objects**
 - leptons (2%)
 - jets: ID, JVF, JER (4%), JES (10%)
 - tagging (5-20%)
- **Background model**
 - tt+jets
 - cross-section (6%)
 - parton shower model (10-15%)
 - reweighting to data (6%)
 - tt+bb/cc normalisation (50%)
 - tt+bb/cc modelling
 - small backgrounds
- **Signal model**
 - scale and PDF choice, MC generator, hadronisation

S = shape, N = normalization



Systematic uncertainty	Type	Components
Luminosity	N	1
Physics Objects		
Electron	SN	5
Muon	SN	6
Jet energy scale	SN	22
Jet vertex fraction	SN	1
Jet energy resolution	SN	1
Jet reconstruction	SN	1
<i>b</i> -tagging efficiency	SN	6
<i>c</i> -tagging efficiency	SN	4
Light jet-tagging efficiency	SN	12
Background Model		
<i>t</i> \bar{t} cross section	N	1
<i>t</i> \bar{t} modelling: p_T reweighting	SN	9
<i>t</i> \bar{t} modelling: parton shower	SN	3
<i>t</i> \bar{t} +heavy-flavour: normalisation	N	2
<i>t</i> \bar{t} + <i>c</i> \bar{c} : HF reweighting	SN	2
<i>t</i> \bar{t} + <i>c</i> \bar{c} : generator	SN	4
<i>t</i> \bar{t} + <i>b</i> \bar{b} : NLO Shape	SN	8
W+jets normalization	N	3
W p_T reweighting	SN	1
Z+jets normalization	N	3
Z p_T reweighting	SN	1
Multijet normalisation	N	3
Multijet shape	S	2
Single top cross section	N	1
Single top model	SN	1
Diboson+jets normalization	N	3
<i>t</i> \bar{t} V cross section	N	1
<i>t</i> \bar{t} V model	SN	1
Signal Model		
<i>t</i> \bar{t} H scale	SN	2
<i>t</i> \bar{t} H Generator	SN	1
<i>t</i> \bar{t} H hadronization	SN	1
<i>t</i> \bar{t} H PDF	SN	1

- **Luminosity** (2.8%)

- **Physics objects**

- leptons (2%)
- jets: ID, JVF, JER (4%), JES (10%)
- tagging (5-20%)

- **Background model**

- tt+jets
 - cross-section (6%)
 - parton shower modelling (10-15%)
 - reweighting to data (6%)
 - tt+bb/cc normalisation (50%)
 - tt+bb/cc modelling
- small backgrounds

- **Signal model**

- scale and PDF choice, MC generator, hadronisation

S = shape, N = normalization

Many systematic uncertainties, both theoretical and experimental



% change in yield in $\geq 6 j, \geq 4 b$	Pre-fit			
	$t\bar{t}H$ (125)	$t\bar{t} + \text{light}$	$t\bar{t} + c\bar{c}$	$t\bar{t} + b\bar{b}$
Luminosity	± 2.8	± 2.8	± 2.8	± 2.8
Lepton efficiencies	± 1.4	± 1.4	± 1.4	± 1.5
Jet energy scale	± 6.4	± 13	± 11	± 9.2
Jet efficiencies	± 1.7	± 5.2	± 2.7	± 2.5
Jet energy resolution	± 0.1	± 4.4	± 2.5	± 1.6
b -tagging efficiency	± 9.2	± 5.6	± 5.1	± 9.3
c -tagging efficiency	± 1.7	± 6.0	± 12	± 2.4
Light jet-tagging efficiency	± 1.0	± 19	± 5.2	± 2.1
High p_T tagging efficiency	± 0.6	–	± 0.7	± 0.6
$t\bar{t}$ modelling: p_T reweighting	–	± 5.4	± 6.1	–
$t\bar{t}$ modelling: parton shower	–	± 13	± 16	± 11
$t\bar{t}$ heavy-flavour: normalisation	–	–	± 50	± 50
$t\bar{t}$ heavy-flavour: modelling	–	± 11	± 16	± 8.3
Theoretical cross sections	–	± 6.3	± 6.3	± 6.3
$t\bar{t}H$ modelling	± 2.7	–	–	–
Total	± 12	± 32	± 59	± 54

Background systematics much larger than expected signal yield!

Total background uncertainty: ~40%

Expected S/B: ~4%



ttbb normalization uncertainty is greatly reduced!

Pre-fit

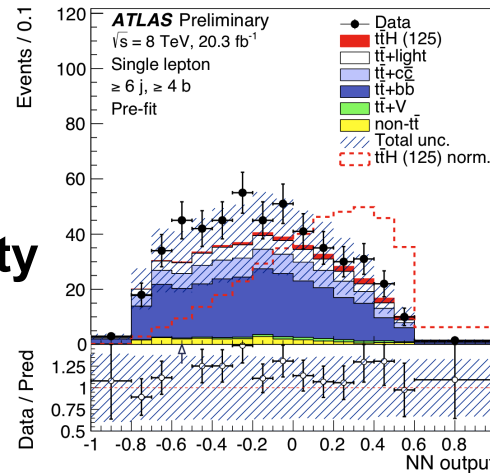

Postfit

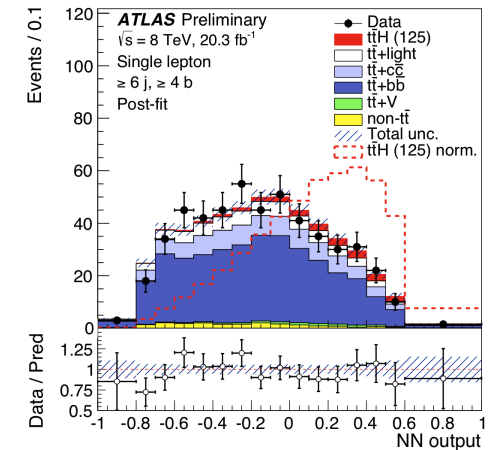

$\geq 6 j, \geq 4 b$	Pre-fit				Post-fit			
	$t\bar{t}H$ (125)	$t\bar{t} + \text{light}$	$t\bar{t} + c\bar{c}$	$t\bar{t} + b\bar{b}$	$t\bar{t}H$ (125)	$t\bar{t} + \text{light}$	$t\bar{t} + c\bar{c}$	$t\bar{t} + b\bar{b}$
Luminosity	± 2.8	± 2.8	± 2.8	± 2.8	± 2.6	± 2.6	± 2.6	± 2.6
Lepton efficiencies	± 1.4	± 1.4	± 1.4	± 1.5	± 1.3	± 1.3	± 1.3	± 1.3
Jet energy scale	± 6.4	± 13	± 11	± 9.2	± 2.3	± 5.3	± 4.7	± 3.6
Jet efficiencies	± 1.7	± 5.2	± 2.7	± 2.5	± 0.7	± 2.3	± 1.2	± 1.1
Jet energy resolution	± 0.1	± 4.4	± 2.5	± 1.6	± 0.1	± 2.3	± 1.3	± 0.8
b -tagging efficiency	± 9.2	± 5.6	± 5.1	± 9.3	± 5.0	± 3.1	± 2.9	± 5.0
c -tagging efficiency	± 1.7	± 6.0	± 12	± 2.4	± 1.4	± 5.1	± 10	± 2.1
Light jet-tagging efficiency	± 1.0	± 19	± 5.2	± 2.1	± 0.6	± 11	± 3.0	± 1.1
High p_T tagging efficiency	± 0.6	–	± 0.7	± 0.6	± 0.3	–	± 0.4	± 0.3
$t\bar{t}$ modelling: p_T reweighting	–	± 5.4	± 6.1	–	–	± 4.7	± 5.4	–
$t\bar{t}$ modelling: parton shower	–	± 13	± 16	± 11	–	± 3.6	± 10	± 6.0
$t\bar{t}$ heavy-flavour: normalisation	–	–	± 50	± 50	–	–	± 28	± 14
$t\bar{t}$ heavy-flavour: modelling	–	± 11	± 16	± 8.3	–	± 3.6	± 9.1	± 7.1
Theoretical cross sections	–	± 6.3	± 6.3	± 6.3	–	± 4.1	± 4.1	± 4.1
$t\bar{t}H$ modelling	± 2.7	–	–	–	± 2.6	–	–	–
Total	± 12	± 32	± 59	± 54	± 6.9	± 9.2	± 23	± 12



- Best fit signal strength
 $\mu = 1.5 \pm 1.1$
in agreement with SM expectation

- Observed (expected) significance of signal
 $1.4 (1.1) \sigma$

- Observed (expected) exclusion limits
 $\sigma < 3.4 (2.2) \times \sigma_{SM} @ 95 \text{ CL}$

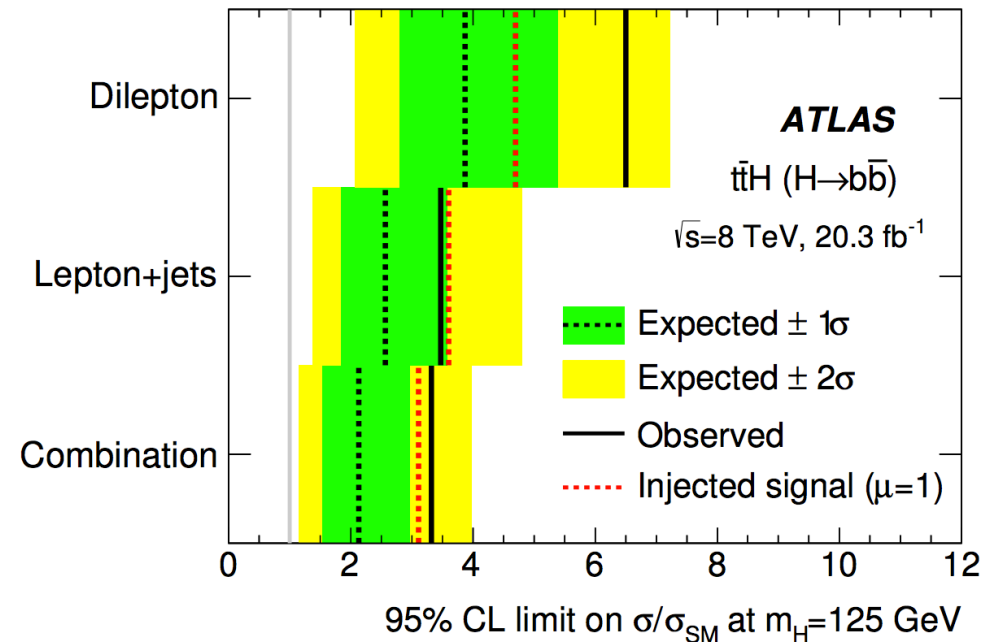
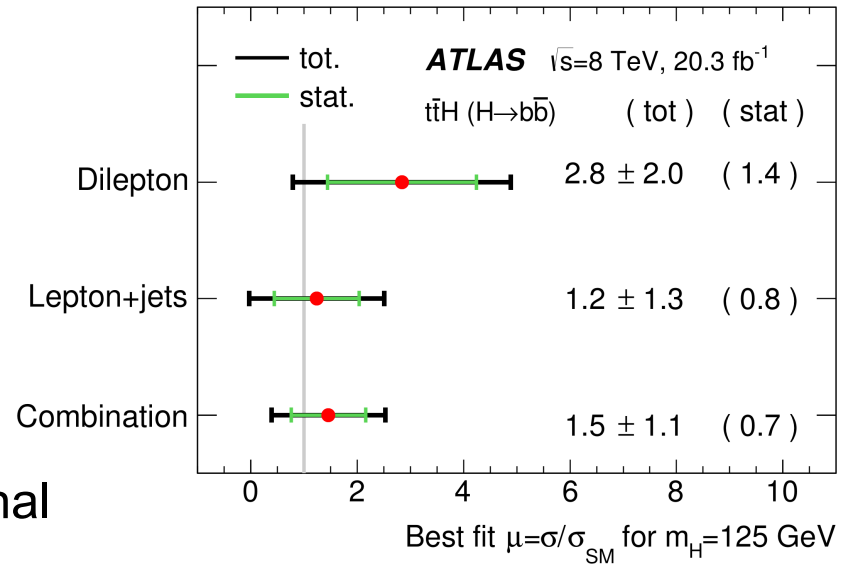

- Best fit signal strength
 $\mu = 1.5 \pm 1.1$
in agreement with SM expectation
- Observed (expected) significance of signal
 $1.4 (1.1) \sigma$
- Observed (expected) exclusion limits
 $\sigma < 3.4 (2.2) \times \sigma_{SM} @ 95 \text{ CL}$

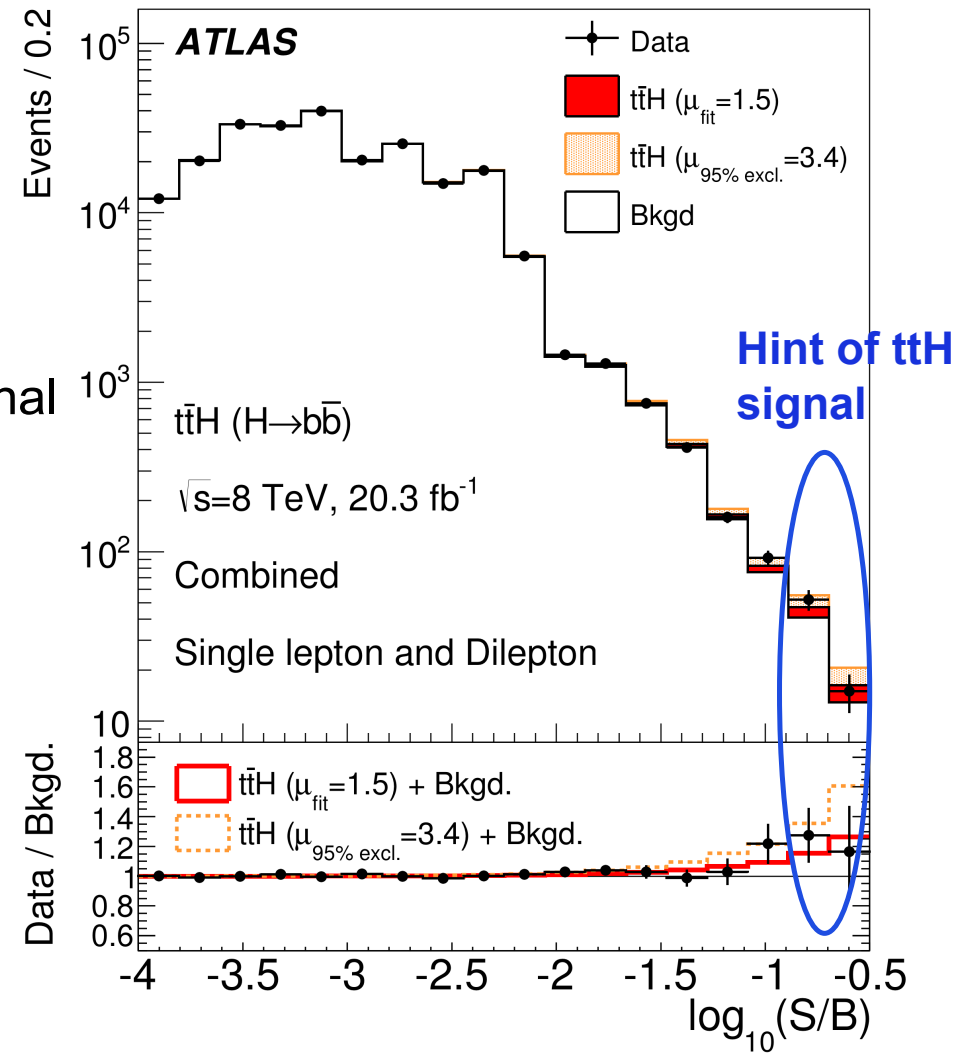

Fitted values of nuisance parameters with largest impact on μ

- Largest effect on μ : normalisation of $t\bar{t}+b\bar{b}$ bkg.
 - is reduced by more than 1/2 from initial 50%
 - the fit prefers an increase (pulled up) in this bkg. of ~40%
- $t\bar{t}+b\bar{b}$ modelling uncertainties affecting the shape of this bkg. also have a significant effect.
 - largest one: the renormalisation scale choice

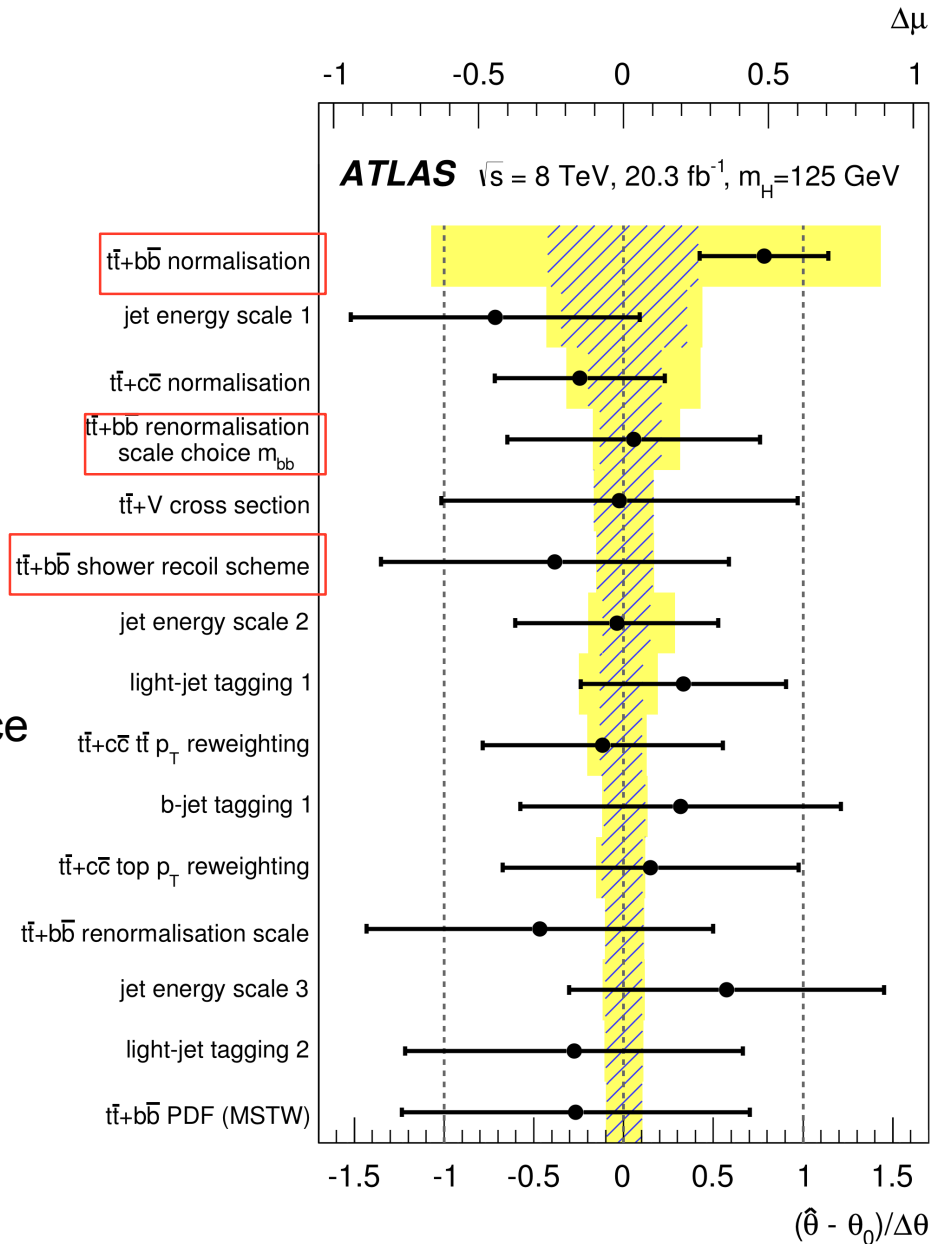
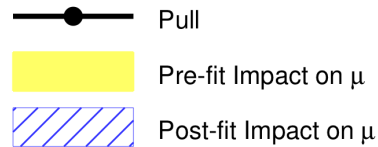

Search for $ttH(H \rightarrow \text{multilepton})$ in ATLAS

[arXiv:1506.05988](https://arxiv.org/abs/1506.05988), accepted by Phys. Lett.

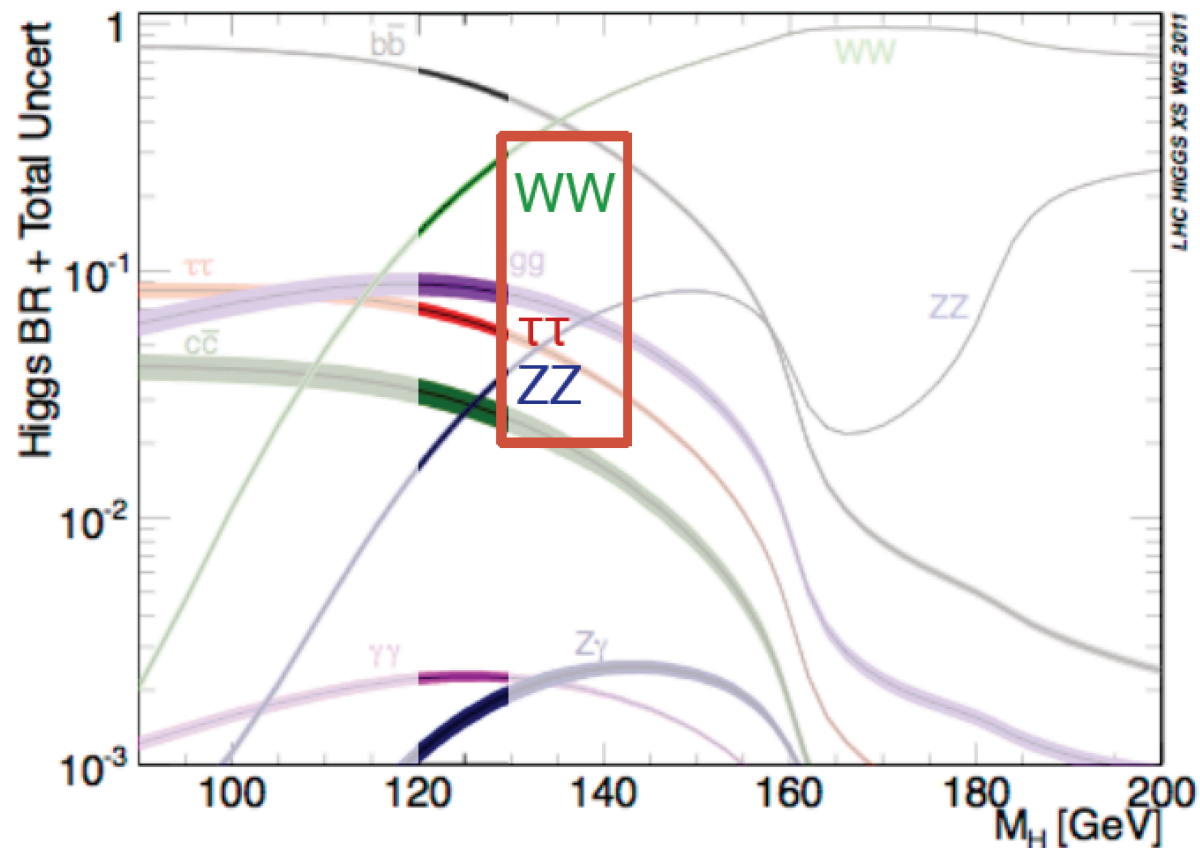

Search for ttH (H → multilepton)

- Sensitive to $H \rightarrow WW, \tau\tau, ZZ$

- Consider 5 final states:

- 2 SS leptons (e/μ), no τ_{had}
- 3 leptons (e/μ), total charge ± 1
- 2 SS leptons (e/μ), 1 τ_{had}
- 4 leptons (e/μ)
- 1 lepton (e/μ), 2 τ_{had}

Category	Higgs boson decay mode			
	WW^*	$\tau\tau$	ZZ^*	Other
$2\ell 0\tau_{\text{had}}$	80%	15%	3%	2%
3ℓ	74%	15%	7%	4%
$2\ell 1\tau_{\text{had}}$	35%	62%	2%	1%
4ℓ	69%	14%	14%	4%
$1\ell 2\tau_{\text{had}}$	4%	93%	0%	3%

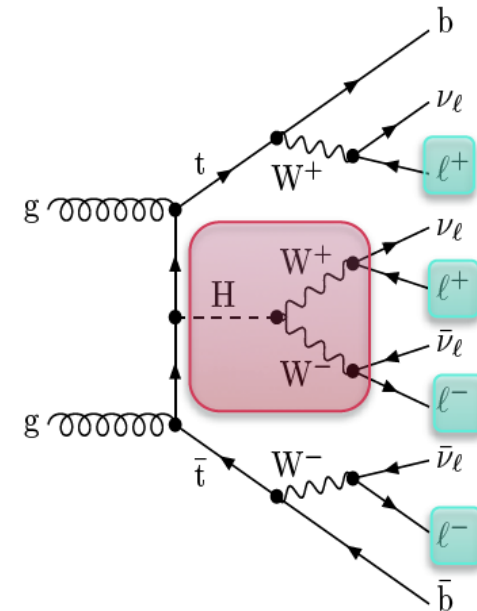
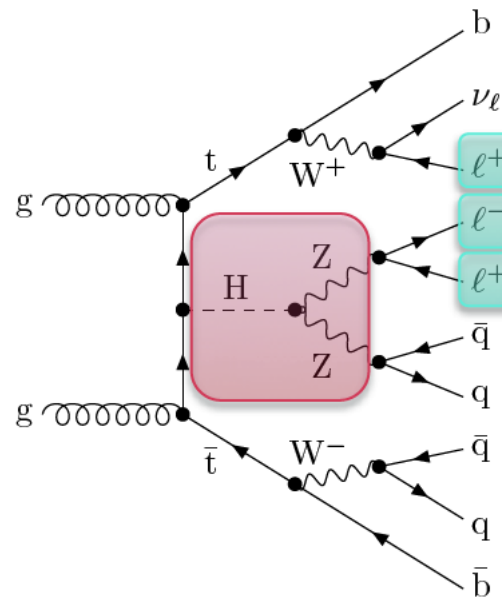
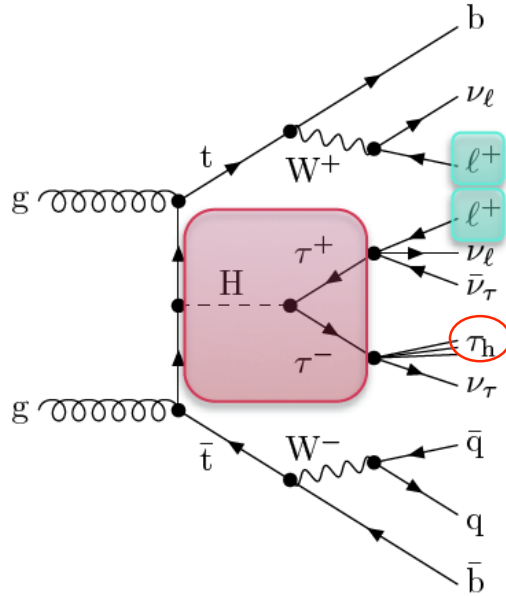



- Sensitive to H→WW, $\tau\tau$, ZZ

- Consider 5 final states:

- **2 SS leptons (e/ μ), no τ_{had}**
- **3 leptons (e/ μ), total charge ± 1**
- **2 SS leptons (e/ μ), 1 τ_{had}**
- **4 leptons (e/ μ)**
- **1 lepton (e/ μ), 2 τ_{had}**

Category	Higgs boson decay mode			
	WW*	$\tau\tau$	ZZ*	Other
$2\ell 0\tau_{\text{had}}$	80%	15%	3%	2%
3ℓ	74%	15%	7%	4%
$2\ell 1\tau_{\text{had}}$	35%	62%	2%	1%
4ℓ	69%	14%	14%	4%
$1\ell 2\tau_{\text{had}}$	4%	93%	0%	3%

- Low rates, but high purity S/B: 0.1-4

- Main backgrounds:

ttV (irreducible, from MC)

tt with non-prompt light leptons (data-driven)

non-prompt taus (MC, validated with data-driven)



Search for $t\bar{t}H$ ($H \rightarrow \text{multilepton}$)

- Best fit signal strength
 $\mu = 2.1^{+1.4}_{-1.2}$
 consistent with SM expectation
- Observed (expected) upper limit
 4.7 (2.4) $\times \sigma_{\text{SM}}$ @ 95 CL

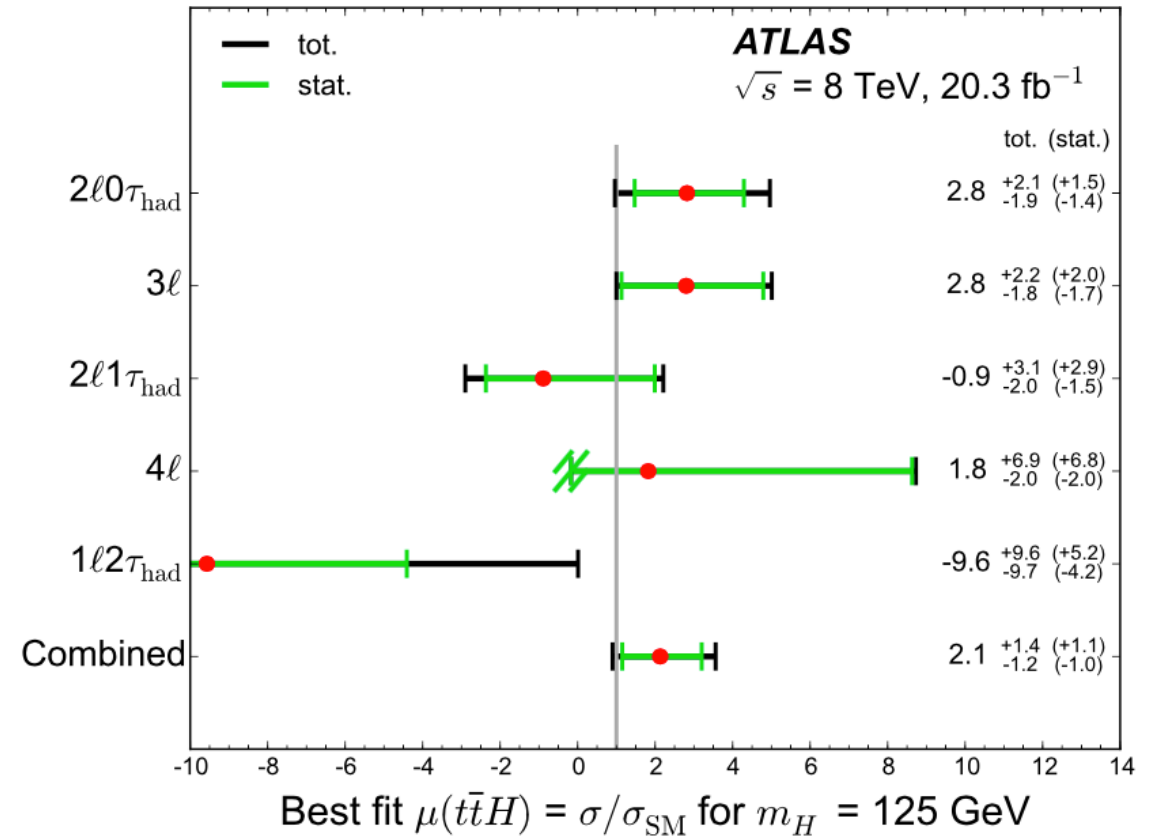

Search for $ttH(H \rightarrow \gamma\gamma)$ in ATLAS

Eur. Phys. J. C (2015) 75:349

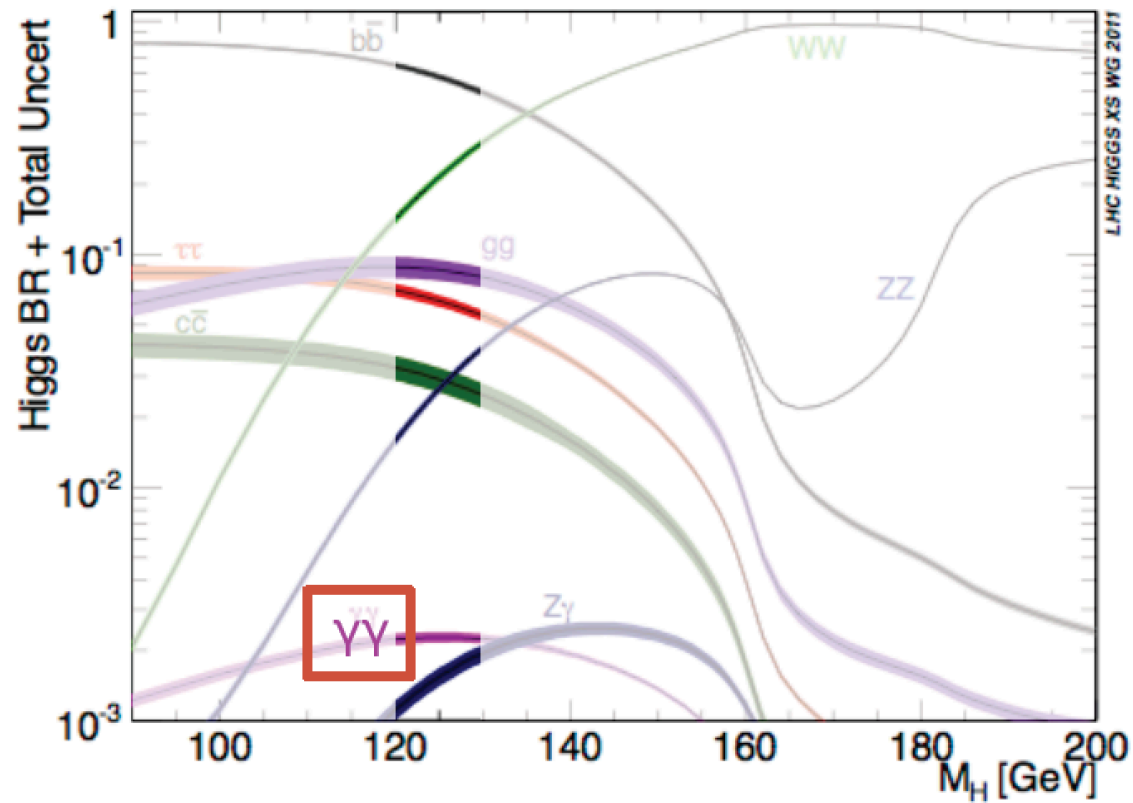



Search for ttH ($H \rightarrow \gamma\gamma$)

- Small BR (0.23%), but excellent mass resolution
- Categorize signal events according to the tt decay mode (leptonic or hadronic). Exploit high jet multiplicity and b-jet content of signal to optimize ttH sensitivity (and to suppress other Higgs production, while keeping good acceptance for tH).
- Discriminant variable: $m_{\gamma\gamma}$
Background determined in sideband analysis.

ttH ($H \rightarrow \gamma\gamma$) candidate event

2 photons, $p_{T1}=61, 39$ GeV, $m_{\gamma\gamma}=126.6$ GeV

1 electron, $p_T=90$ GeV

$E_{\text{miss}}^T = 43$ GeV

4 jets, $p_T=75, 71, 50, 39$ GeV, 1 muon-tagged jet

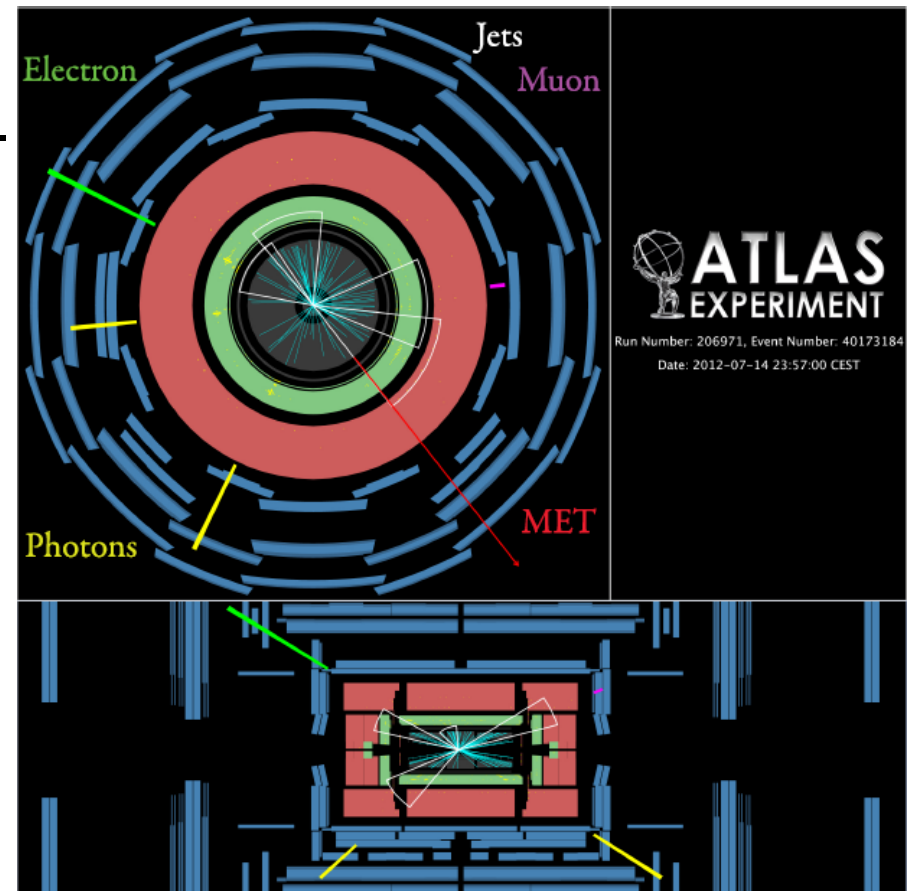



Search for ttH (H → γγ)

- Best fit signal strength
 $\mu = 1.3^{+2.6}_{-1.8}$
Consistent with SM expectation
- Observed (expected) upper limit
 $6.7 (4.9) \times \sigma_{SM} @ 95 \text{ CL}$

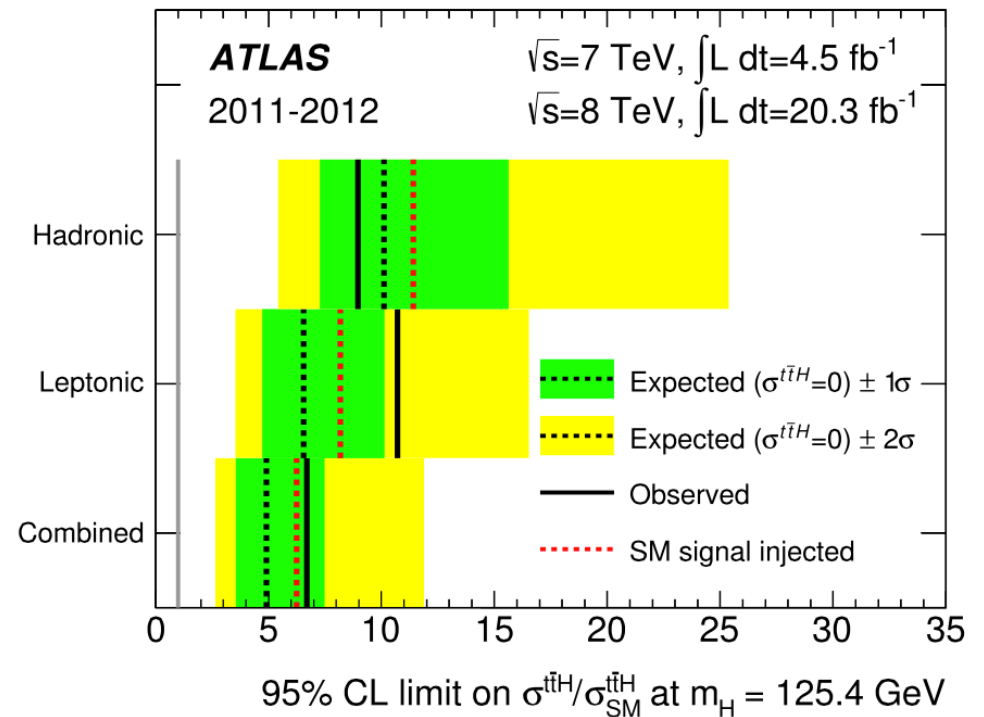

	Observed upper limit @ 95 CL	Expected upper limit @ 95 CL	Signal strength
H → bb	3.4 x σ_{SM}	2.2 x σ_{SM}	1.5 ± 1.1
H → multilepton	4.7 x σ_{SM}	2.4 x σ_{SM}	2.1 ^{+1.4} _{-1.2}
H → γγ	6.7 x σ_{SM}	4.9 x σ_{SM}	1.3 ^{+2.6} _{-1.8}

Currently only upper limits on ttH...



Combinations





ATLAS

Individual analysis

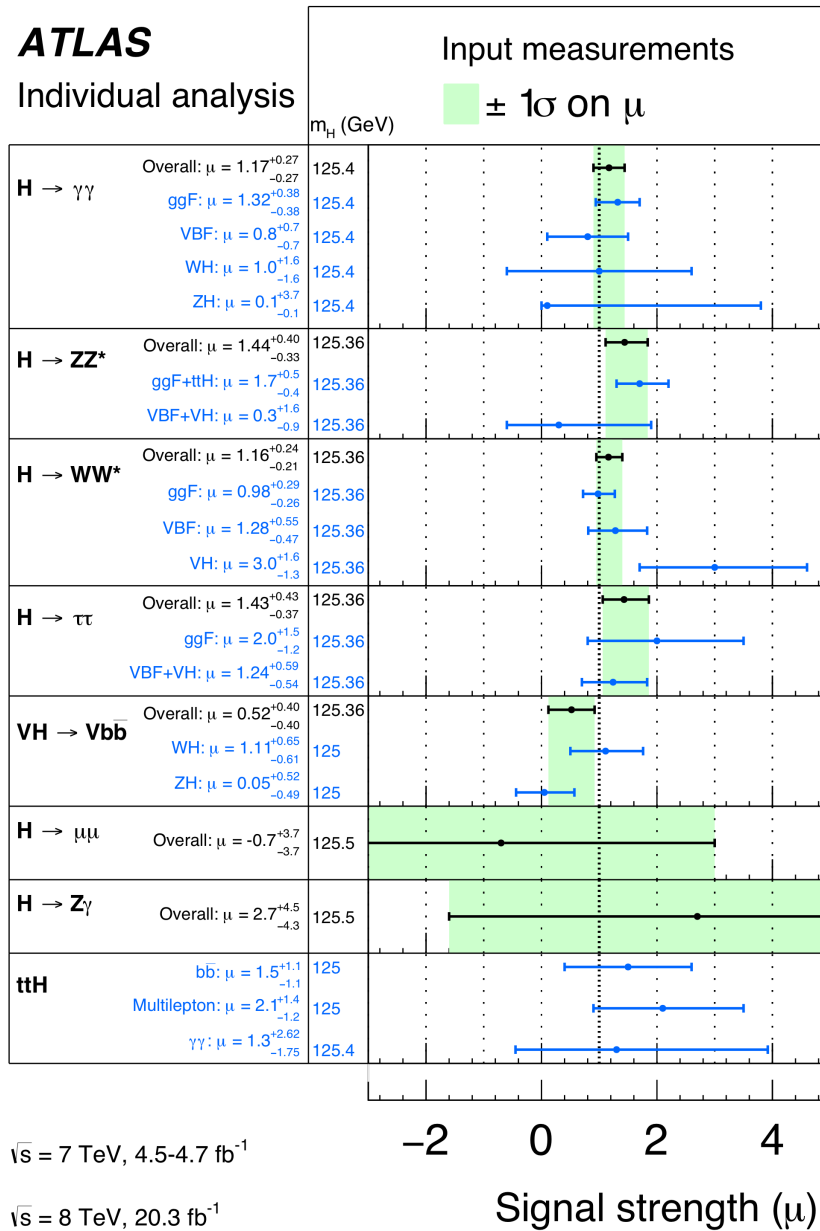

Summary of signal-strength measurements from individual analyses.

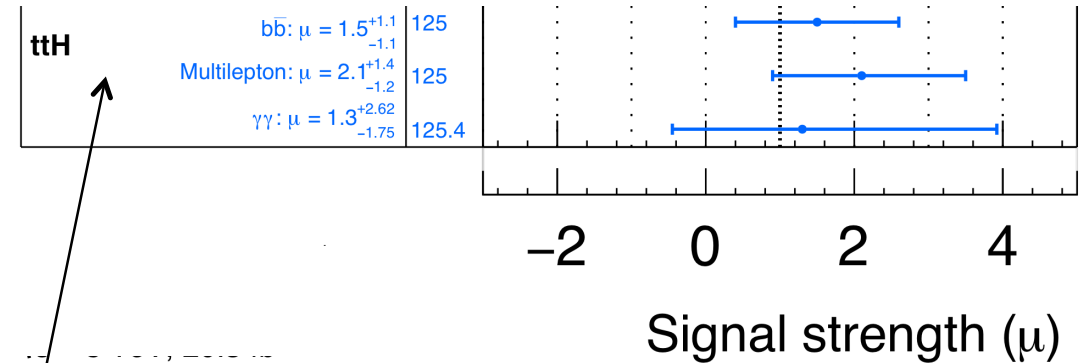

Grouping by production mechanism
to extract information on each production processes assuming SM values for decay channels

$$\mu_{ggF} = 1.23^{+0.23}_{-0.20}$$

$$\mu_{VBF} = 1.23 \pm 0.32$$

$$\mu_{VH} = 0.80 \pm 0.36$$

$$\mu_{ttH} = 1.81 \pm 0.80$$

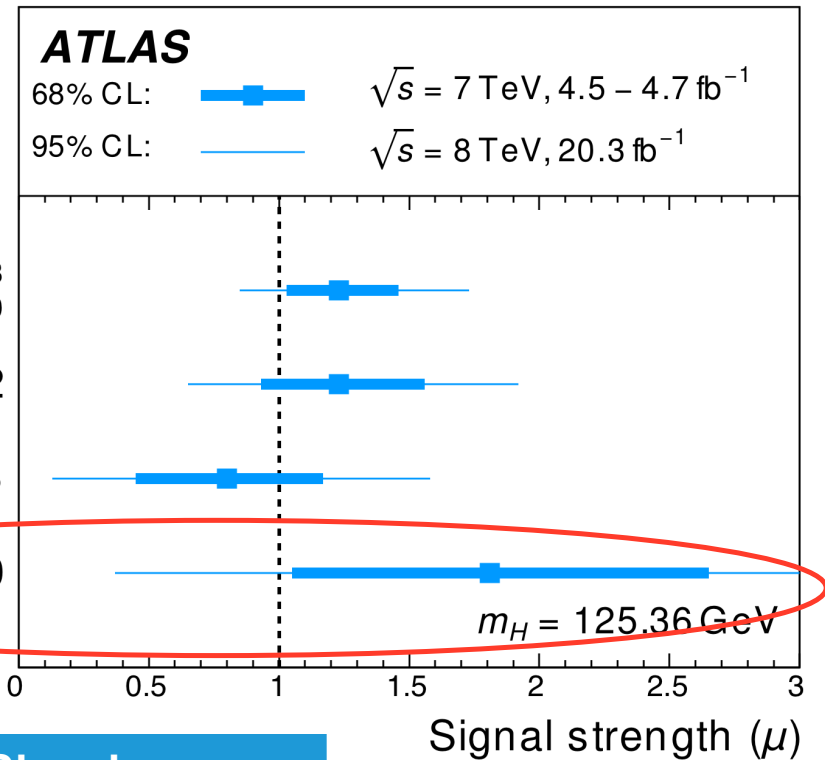

	Observed upper limit @ 95 CL	Expected upper limit @ 95 CL	Signal strength
$H \rightarrow b\bar{b}$	$3.4 \times \sigma_{SM}$	$2.2 \times \sigma_{SM}$	1.5 ± 1.1
$H \rightarrow \text{multilepton}$	$4.7 \times \sigma_{SM}$	$2.4 \times \sigma_{SM}$	$2.1^{+1.4}_{-1.2}$
$H \rightarrow \gamma\gamma$	$6.7 \times \sigma_{SM}$	$4.9 \times \sigma_{SM}$	$1.3^{+2.6}_{-1.8}$
Combination	$3.2 \times \sigma_{SM}$	$1.4 \times \sigma_{SM}$	1.81 ± 0.80



- The precise measurement of the top Yukawa coupling may provide insights on the underlying mechanism for EWSB and whether or not the top quark plays a role in it.
 - The program of searches for ttH production at the LHC is well underway, with all main decay modes being explored ($H \rightarrow bb$, WW , $\tau\tau$, ZZ and $\gamma\gamma$):
 - $H \rightarrow bb$ has turned out to be just as challenging as anticipated.
Much experience has been gained on how to reduce the impact from systematic uncertainties by exploiting high-statistics data samples.
Recent progress on the theoretical description of tt+jets background being exploited.
Jet substructure techniques potentially promising in this channel.
 - Expect combination of all ttH channels soon, also with CMS.
- ttH observation and Yukawa coupling measurement will be a highlight in Run 2**
- We are in a good starting position to perform it 😊**



BACK-UP



Variable	Definition	NN rank			
		$\geq 6j, \geq 4b$	$\geq 6j, 3b$	$5j, \geq 4b$	$5j, 3b$
$D1$	Neyman–Pearson MEM discriminant (Eq. (4))	1	10	-	-
Centrality	Scalar sum of the p_T divided by sum of the E for all jets and the lepton	2	2	1	-
$p_T^{\text{jet}5}$	p_T of the fifth leading jet	3	7	-	-
$H1$	Second Fox–Wolfram moment computed using all jets and the lepton	4	3	2	-
$\Delta R_{bb}^{\text{avg}}$	Average ΔR for all b -tagged jet pairs	5	6	5	-
SSL	Logarithm of the summed signal likelihoods (Eq. (2))	6	4	-	-
$m_{bb}^{\text{min } \Delta R}$	Mass of the combination of the two b -tagged jets with the smallest ΔR	7	12	4	4
$m_{bj}^{\text{max } p_T}$	Mass of the combination of a b -tagged jet and any jet with the largest vector sum p_T	8	8	-	-
$\Delta R_{bb}^{\text{max } p_T}$	ΔR between the two b -tagged jets with the largest vector sum p_T	9	-	-	-
$\Delta R_{\text{lep}-bb}^{\text{min } \Delta R}$	ΔR between the lepton and the combination of the two b -tagged jets with the smallest ΔR	10	11	10	-
$m_{uu}^{\text{min } \Delta R}$	Mass of the combination of the two untagged jets with the smallest ΔR	11	9	-	2
$A_{\text{plan}_{b-\text{jet}}}$	$1.5\lambda_2$, where λ_2 is the second eigenvalue of the momentum tensor[92] built with only b -tagged jets	12	-	8	-
N_{40}^{jet}	Number of jets with $p_T \geq 40\text{GeV}$	-	1	3	-
$m_{bj}^{\text{min } \Delta R}$	Mass of the combination of a b -tagged jet and any jet with the smallest ΔR	-	5	-	-
$m_{jj}^{\text{max } p_T}$	Mass of the combination of any two jets with the largest vector sum p_T	-	-	6	-
H_T^{had}	Scalar sum of jet p_T	-	-	7	-
$m_{jj}^{\text{min } \Delta R}$	Mass of the combination of any two jets with the smallest ΔR	-	-	9	-
$m_{bb}^{\text{max } p_T}$	Mass of the combination of the two b -tagged jets with the largest vector sum p_T	-	-	-	1
$p_{T,uu}^{\text{min } \Delta R}$	Scalar sum of the p_T of the pair of untagged jets with the smallest ΔR	-	-	-	3
$m_{bb}^{\text{max } m}$	Mass of the combination of the two b -tagged jets with the largest invariant mass	-	-	-	5
$\Delta R_{uu}^{\text{min } \Delta R}$	Minimum ΔR between the two untagged jets	-	-	-	6
m_{jjj}	Mass of the jet triplet with the largest vector sum p_T	-	-	-	7



Variable	Definition	NN rank		
		$\geq 4j, \geq 4b$	$\geq 4j, 3b$	$3j, 3b$
$\Delta\eta_{jj}^{\max} \Delta\eta$	Maximum $\Delta\eta$ between any two jets in the event	1	1	1
$m_{bb}^{\min} \Delta R$	Mass of the combination of the two b -tagged jets with the smallest ΔR	2	8	-
$m_{b\bar{b}}$	Mass of the two b -tagged jets from the Higgs candidate system	3	-	-
$\Delta R_{hl}^{\min} \Delta R$	ΔR between the Higgs candidate and the closest lepton	4	5	-
N_{30}^{Higgs}	Number of Higgs candidates within 30 GeV of the Higgs mass of 125 GeV	5	2	5
$\Delta R_{bb}^{\max} p_T$	ΔR between the two b -tagged jets with the largest vector sum p_T	6	4	8
$A_{\text{plan}_{\text{jet}}}$	$1.5\lambda_2$, where λ_2 is the second eigenvalue of the momentum tensor built with all jets	7	7	-
$m_{jj}^{\min} m$	Minimum dijet mass between any two jets	8	3	2
$\Delta R_{hl}^{\max} \Delta R$	ΔR between the Higgs candidate and the furthest lepton	9	-	-
m_{jj}^{closest}	Dijet mass between any two jets closest to the Higgs mass of 125 GeV	10	-	10
H_T	Scalar sum of jet p_T and lepton p_T values	-	6	3
$\Delta R_{bb}^{\max} m$	ΔR between the two b -tagged jets with the largest invariant mass	-	9	-
$\Delta R_{lj}^{\min} \Delta R$	Minimum ΔR between any lepton and jet	-	10	-
Centrality	Sum of the p_T divided by sum of the E for all jets and both leptons	-	-	7
$m_{jj}^{\max} p_T$	Mass of the combination of any two jets with the largest vector sum p_T	-	-	9
H_4	Fifth Fox–Wolfram moment computed using all jets and both leptons	-	-	4
p_T^{jet3}	p_T of the third leading jet	-	-	6

ttH signal: PowHel+Pythia (ATLAS), Pythia (CMS)

Backgrounds:

- tt+jets: Powheg+Pythia (ATLAS), MadGraph+Pythia (CMS)
- ttW, ttZ: MadGraph+Pythia
- W/Z/ γ^* +jets: Alpgen+Pythia (ATLAS), MadGraph+Pythia(CMS)
- Single top: Powheg+Pythia (ATLAS), Powheg+Pythia (CMS)
- Dibosons: **ALPGEN+HERWIG** (ATLAS), Pythia (CMS)
- Multijets: normalization and shape data-driven (matrix method)

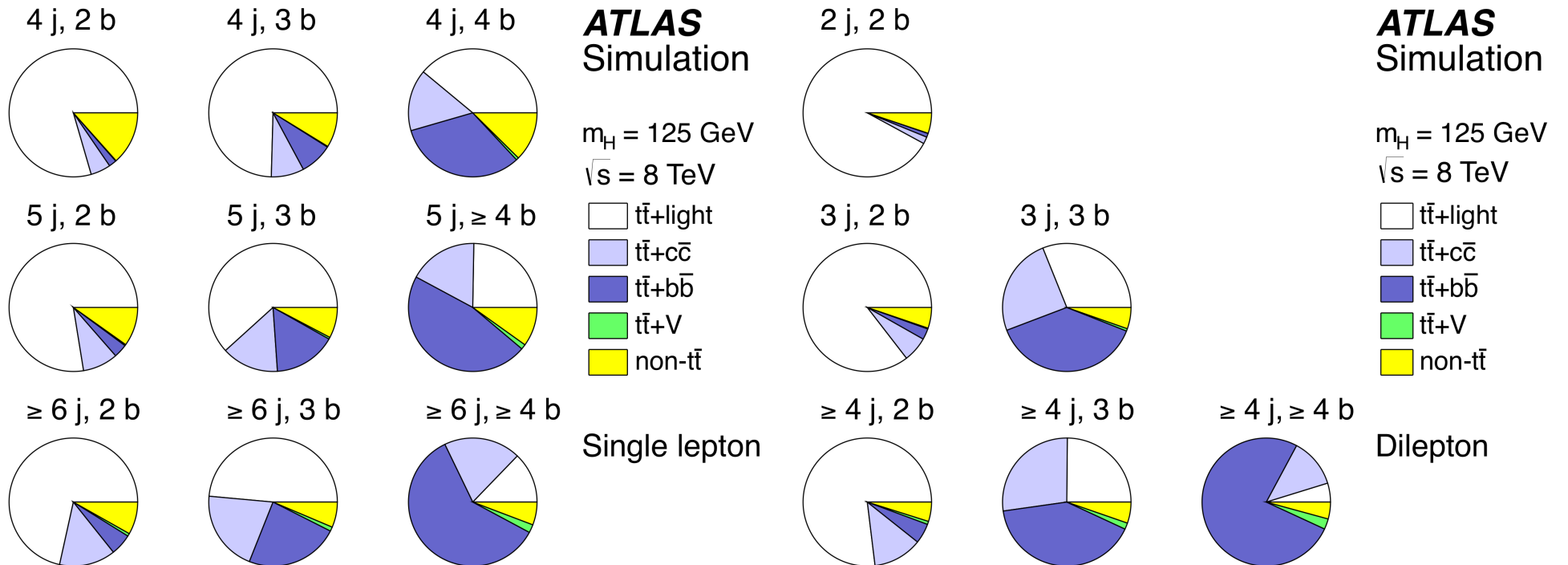
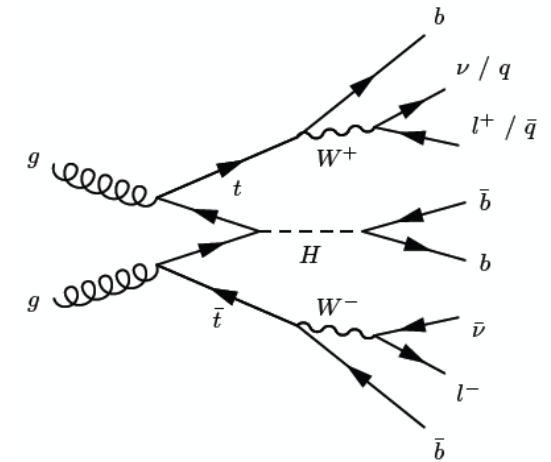



4 j, 2 b

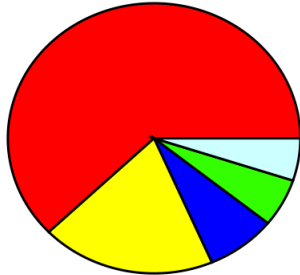

4 j, 3 b

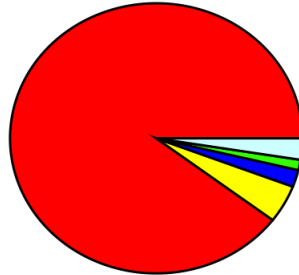

4 j, 4 b

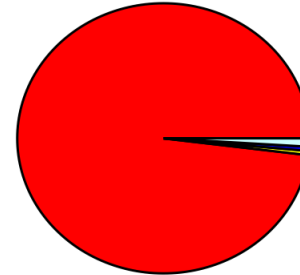

ATLAS Simulation

$m_H = 125 \text{ GeV}$
 $\sqrt{s} = 8 \text{ TeV}$



5 j, 2 b

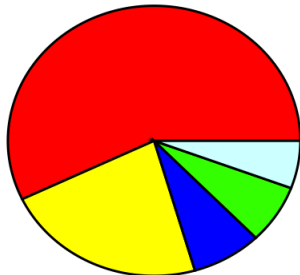

5 j, 3 b

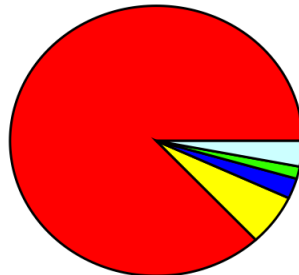

5 j, ≥ 4 b

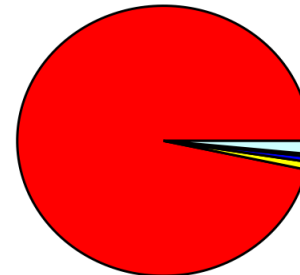

≥ 6 j, 2 b

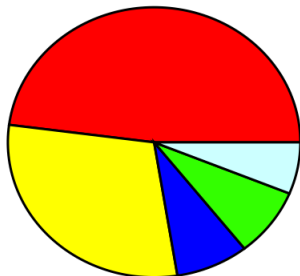

≥ 6 j, 3 b

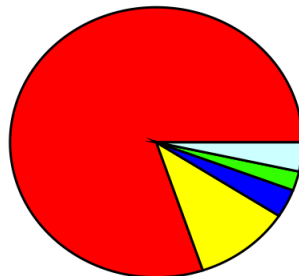

≥ 6 j, ≥ 4 b

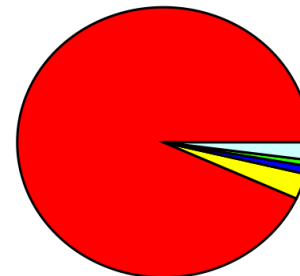

Single lepton

Lepton+tau

- similar to dilepton analysis
- low statistics
- significant tau fakes contribution from light jets

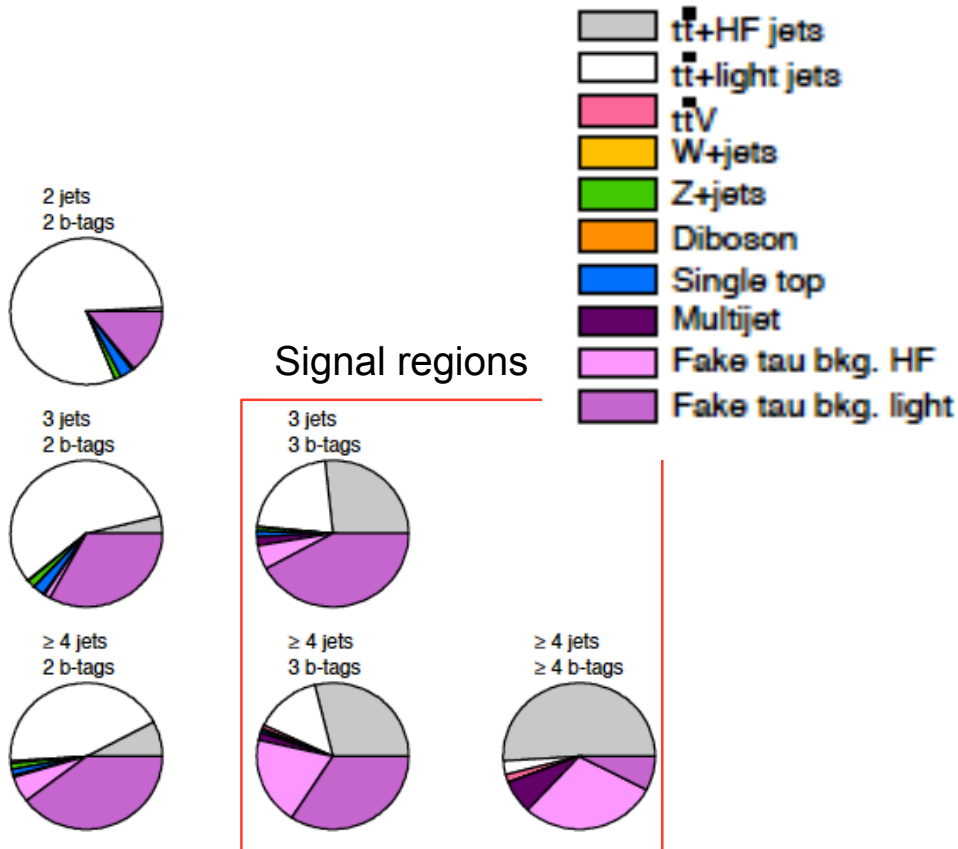

All-hadronic

8 jets, 4 b-jets
main background:
QCD, derived in data
control regions with =2 b-jets

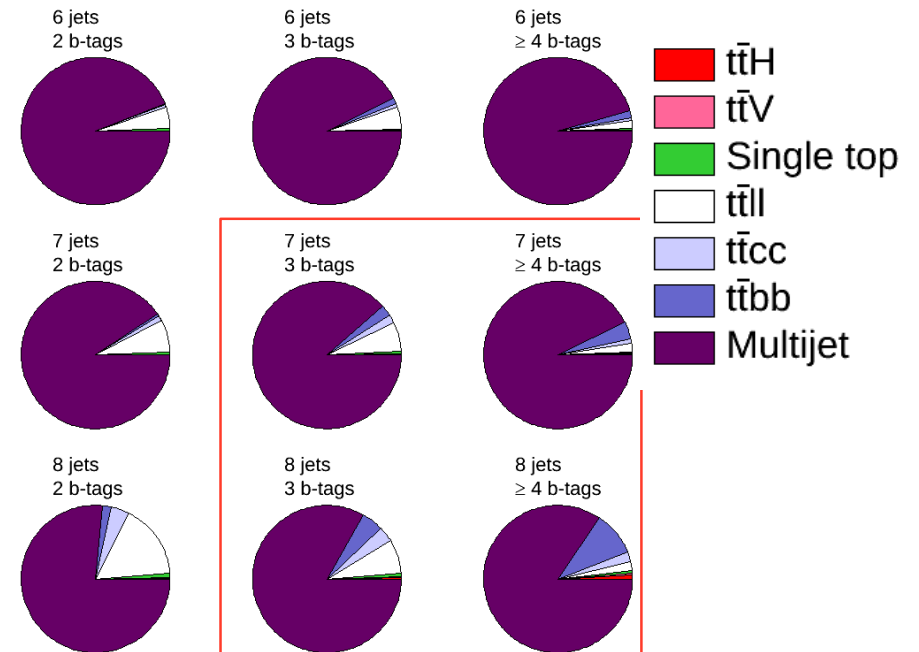
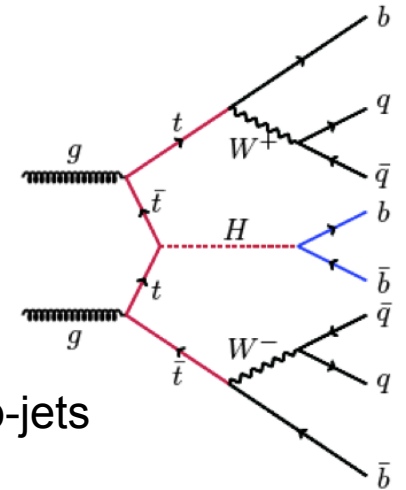



B-TAGGING CALIBRATION

TRUTH TAGGING (tag rate function) instead of direct b-tagging

- essential to have meaningful shapes and deal with low statistics (high # b-jets)
- the idea behind is that:
 - there is not a real cut on N_b jets (i.e no direct b-tagging but keep all events for a given N_{jets})
 - instead, all events are weighted according to the probability to have N_b in an event with N_{jets}

$$\begin{aligned}
 \blacktriangleright P_{N_B=1} &= \sum_{i=1}^{N_J} \left(\epsilon_i \prod_{j \neq i} (1 - \epsilon_j) \right) \\
 \blacktriangleright P_{N_B=0} &= \prod_{j=1}^{N_J} (1 - \epsilon_j) \\
 \blacktriangleright P_{N_B \geq 1} &= 1 - P_{N_B=0} \\
 \blacktriangleright P_{N_B=2} &= \sum_{i=1}^{N_J} \left[\epsilon_i \sum_{j=i+1}^{N_J} \left(\epsilon_j \prod_{k \neq i, k \neq j} (1 - \epsilon_k) \right) \right]
 \end{aligned}$$

Build all possible perm. and the associated probability
To use the tagged jets: pick randomly one perm.

- it relies on two assumptions:
 - the tagging efficiency is correctly parameterised as a function of p_T , η and flavour
 - the probability of tagging a jet is independent of the presence of other jets in the event



ttH SIGNAL MODELLING

- PowHel+Pythia8 was used in Run 1
- need to assess associated unc:
scale choice, showering model, PDF set, etc.
- study of new NLO generators (MadGraph5_aMC@NLO, Sherpa, Powheg) is ongoing towards Run 2

tt+jets BACKGROUND MODELLING

- modelled with Powheg+Pythia
- top p_T and tt p_T reweighted to match data (diff. cross section measurement at 7 TeV)

- ongoing studies with other generators

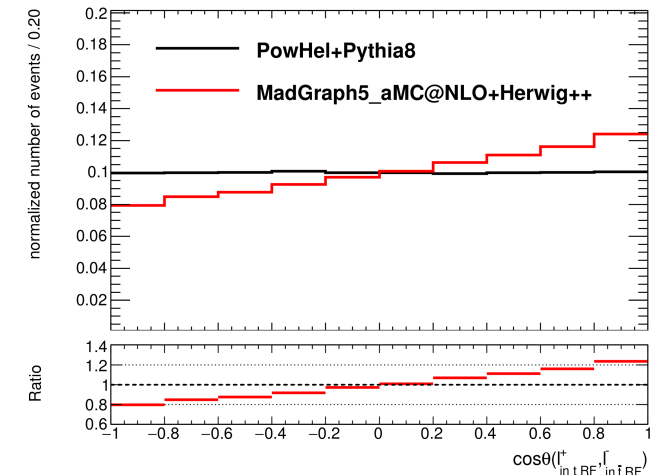
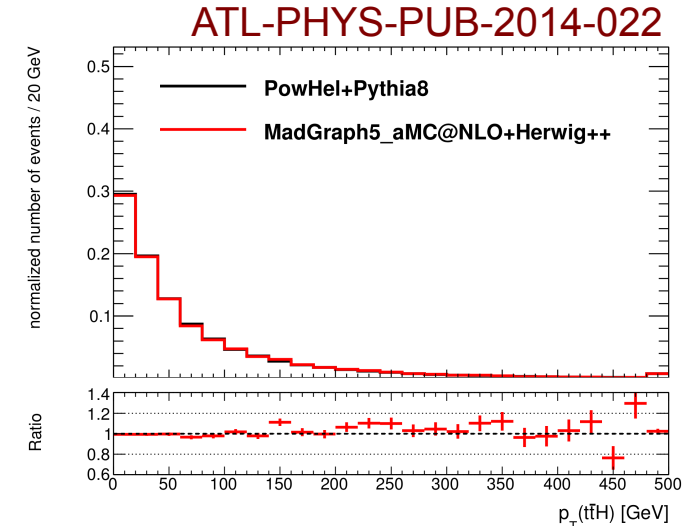
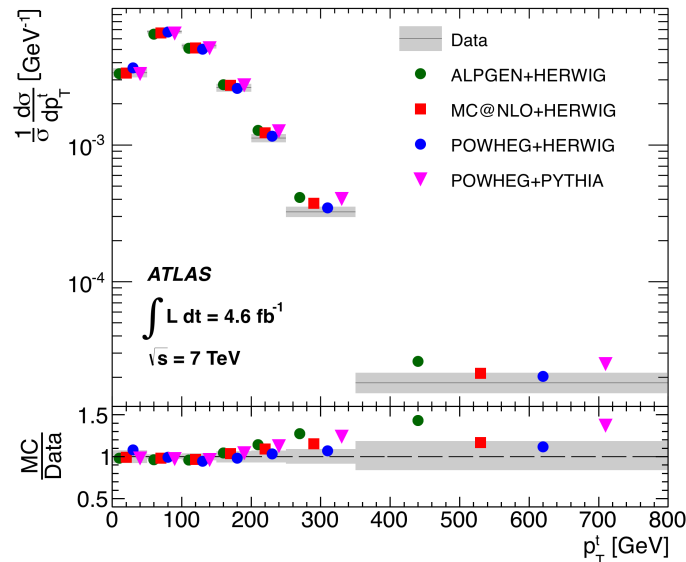

Observables sensitive to spin correlations: useful tool for enhancing sensitivity of S/B on ttH

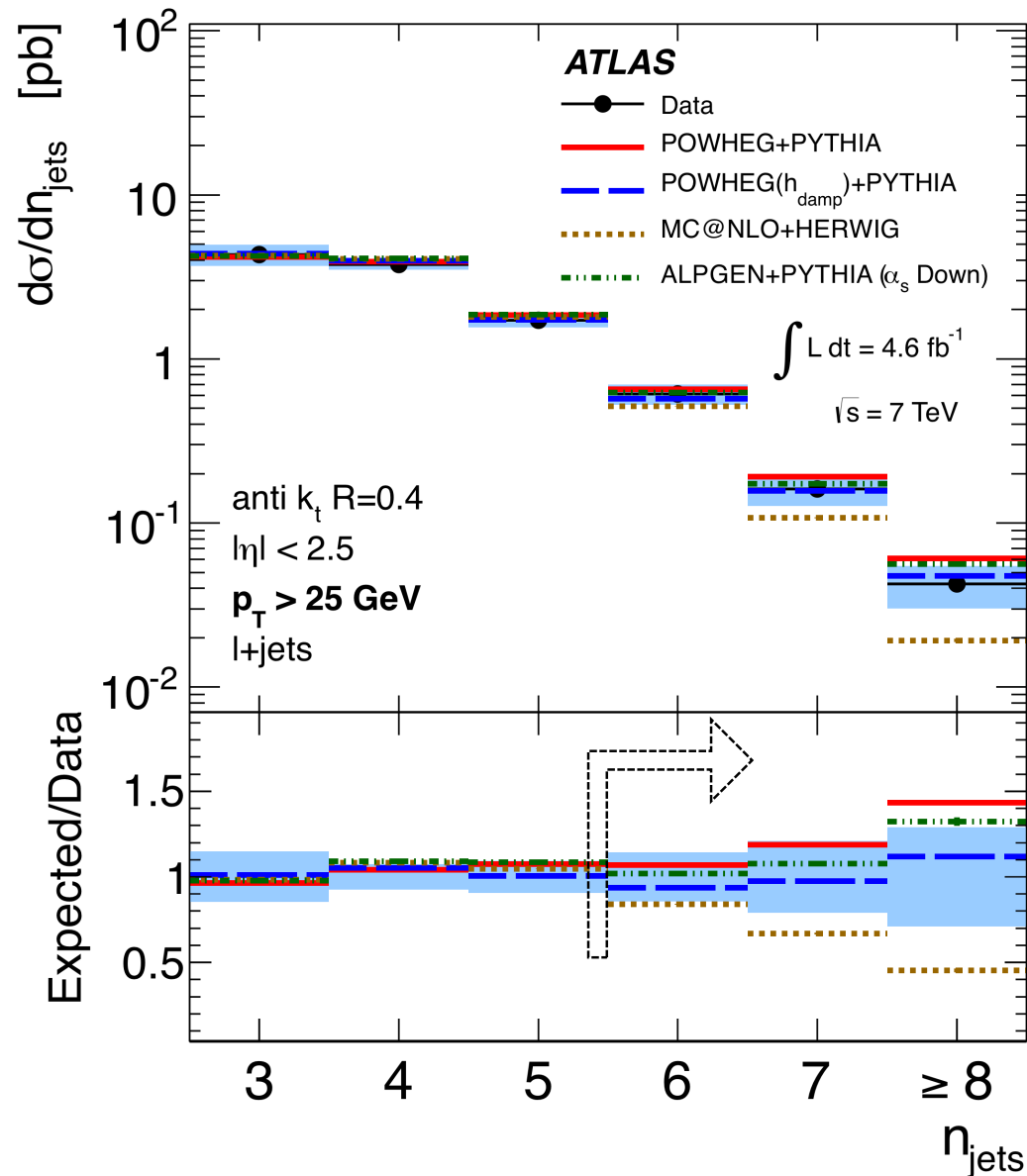

h_{damp} : parameter to regulate hardness of first radiation

Same order (NLO) generators show different behaviour:

- MC@NLO deviates from data for ≥ 5 jets
 - Powheg+Pythia provides a reasonable description of data.
- It was observed that changing one of the settings ($h_{\text{damp}} = m_{\text{top}}$), the agreement with data improves.

Ongoing activities:

- New generators available such as MadGraph5_aMC@NLO and Sherpa are also been studied.



Leading jet p_T is correlated with $t\bar{t}$ system at high- p_T

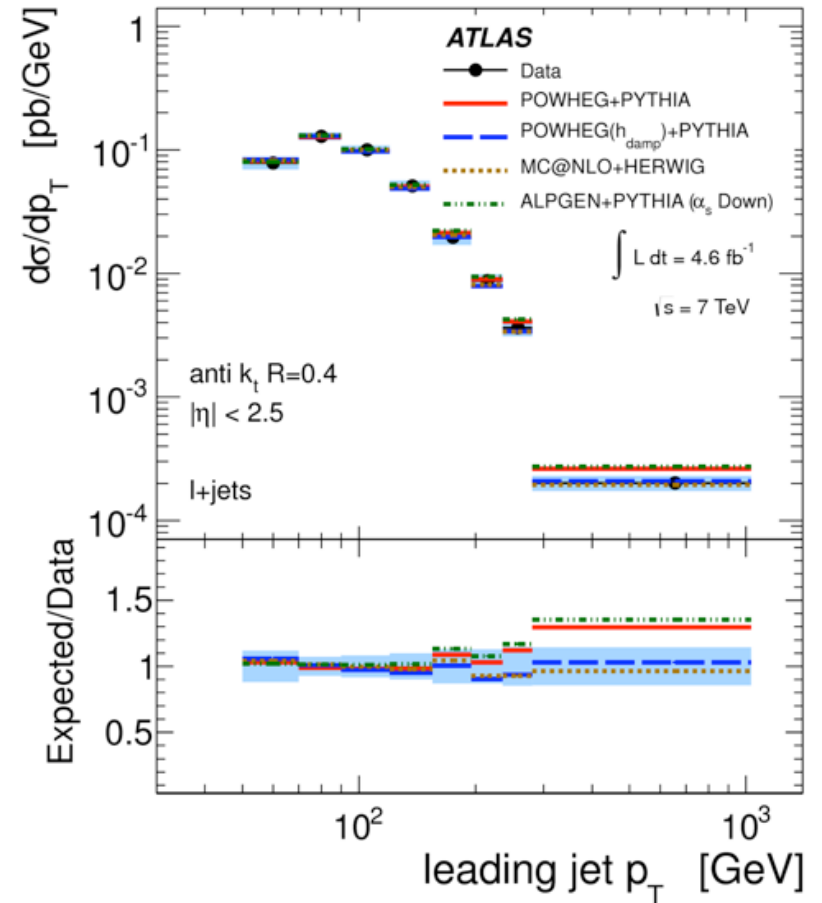
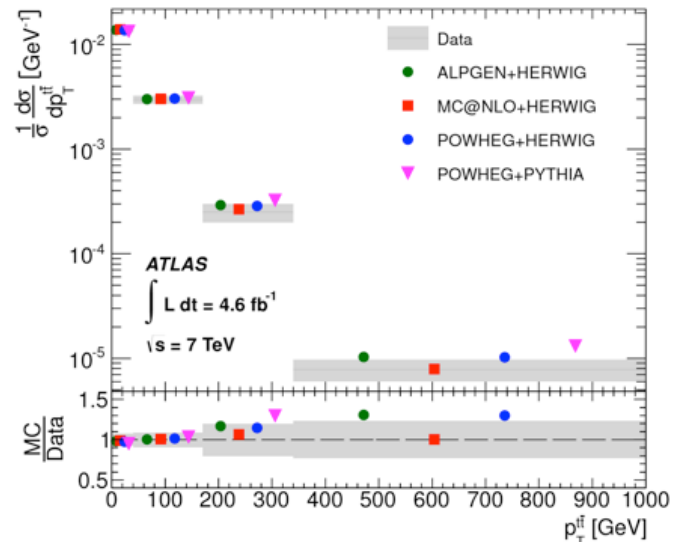
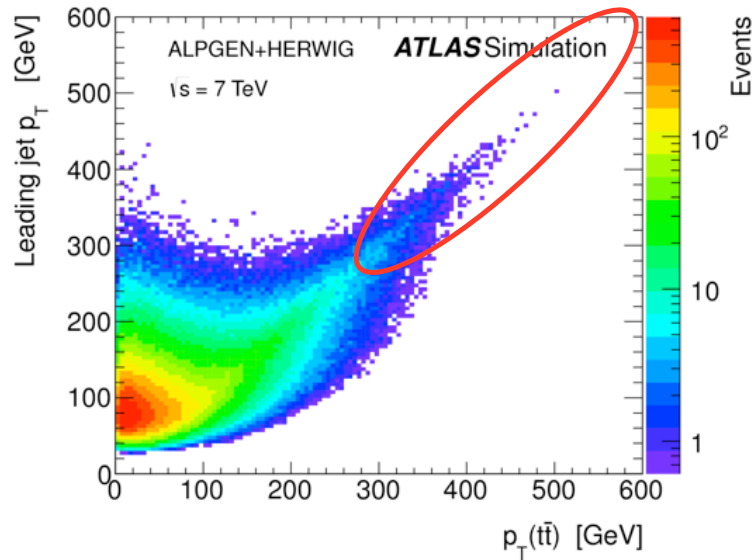

- All generators agree for jet $p_T < 100 \text{ GeV}$ for up to 4th jet.
- Leading jet p_T is best described by MC@NLO and Powheg ($h_{\text{damp}} = m_{\text{top}}$)+Pythia.
- Default Powheg+Pythia describes well p_T of 2nd jet and higher.

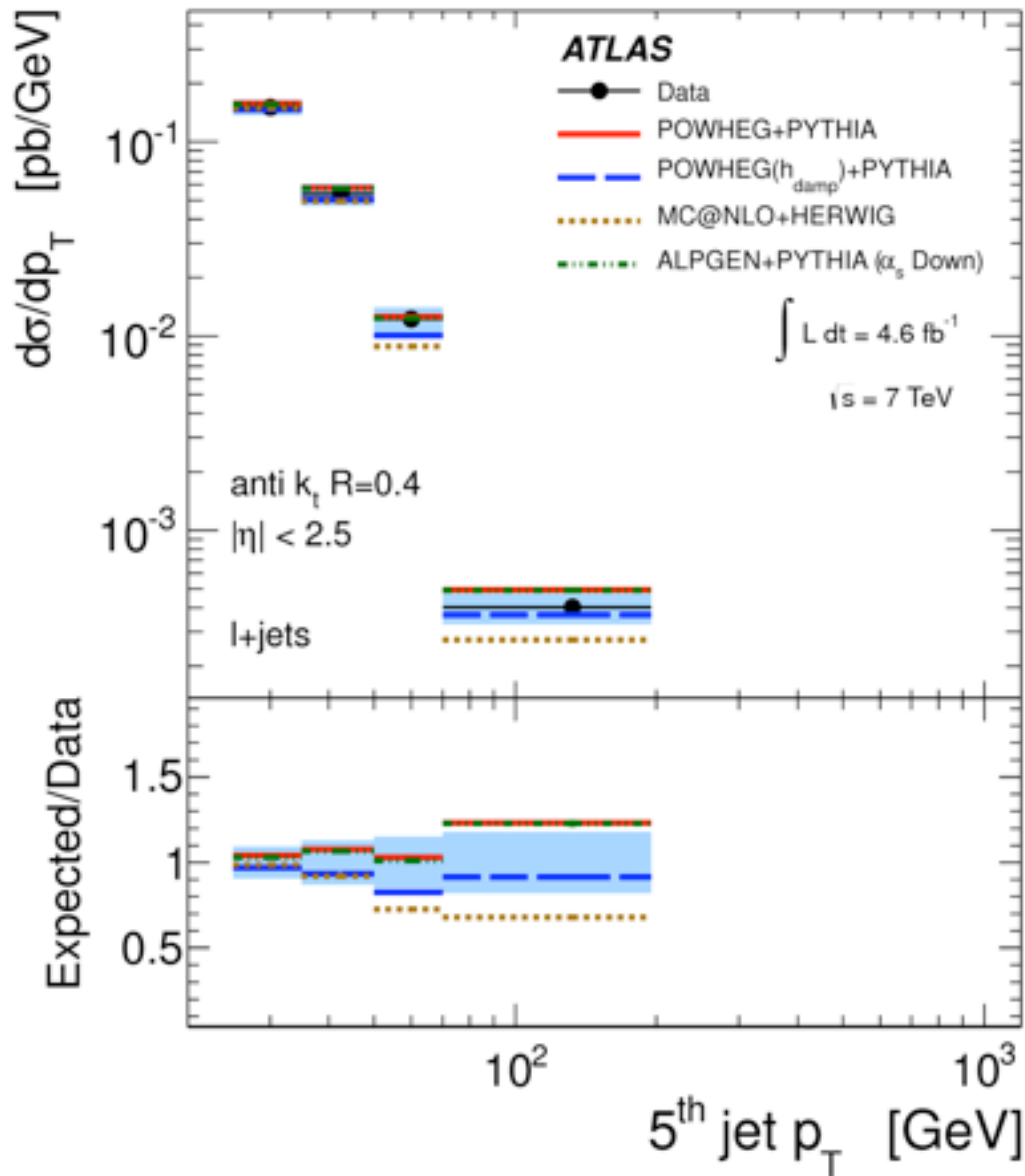

- Significant difference between generators in the description of 5th jet p_T , reflects different ISR/FSR models
- similar conclusions as for jet multiplicity: MC@NLO predicts softer 5th jet p_T than observed in data.



ttH modelling

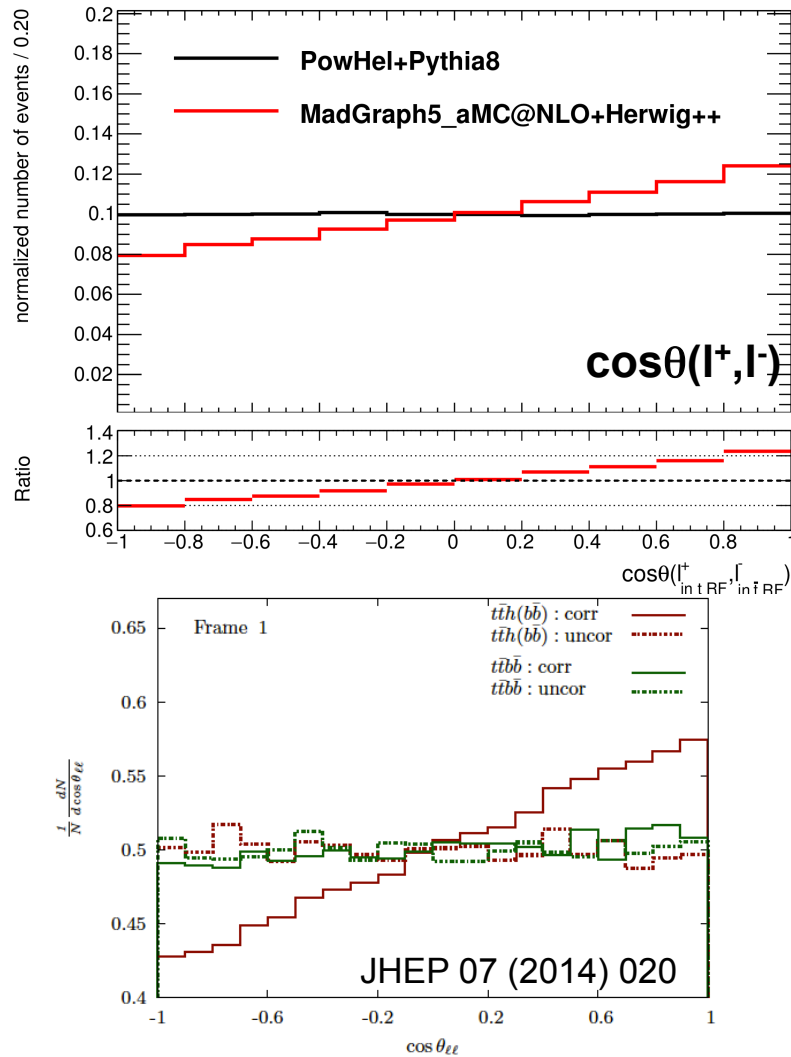

Observables sensitive to spin correlations: useful tool for enhancing sensitivity of S/B on ttH

ttbar modelling

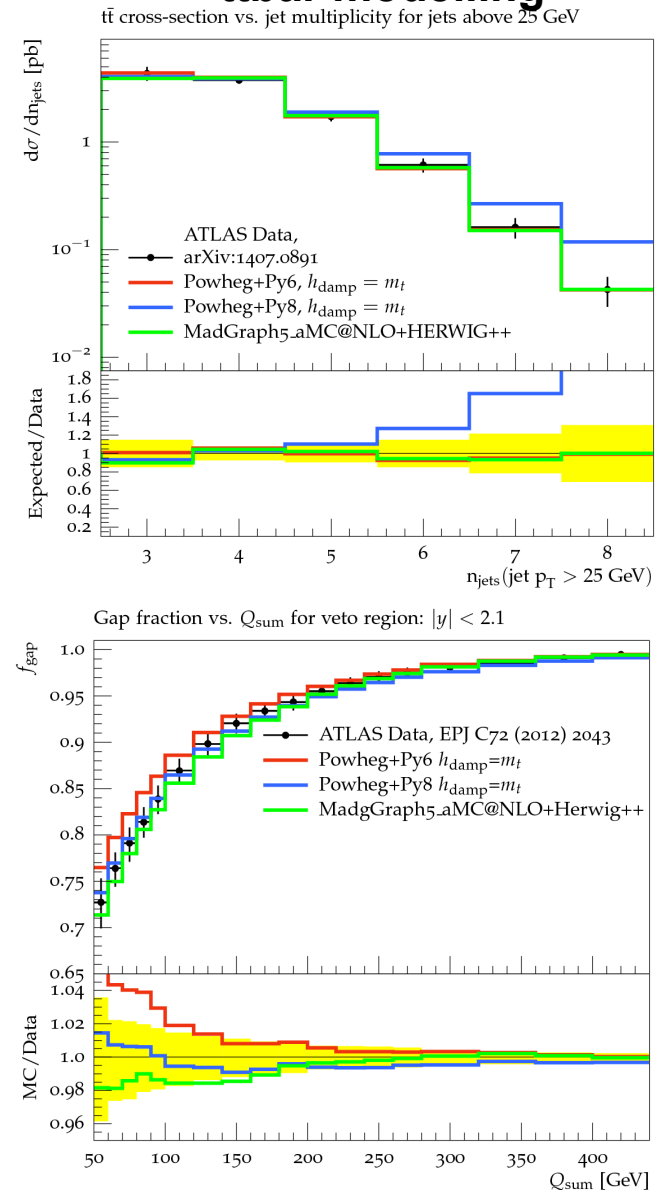



- luminosity (2.8%)
- cross-section normalisation (includes ttbb and ttcc 50% norm. unc.)
- b-tagging, c-tagging, mis-tagging
- JES (22 EV: 3 stat, 3 detector, 4 modelling, 2 mixed, 2 flavour, 4 pile-up, 2 eta-inter., 1 b-jes, 1 single part.)
- JER
- JETEFF
- JVF
- lepton ID/trigger/reco SF, energy scale and resolution
- tau ID SF and energy scale (+ others related to tau fake estimation ?)
- ttH modelling (scale, parton shower, PDF)
- ttbar+light modelling:
 - RW to data: 9 unc. from diff. XS measurement
 - parton shower: 1 unc.
- tt+cc modelling:
 - RW to data: 2 unc. (no top pt and no ttbar RW)
 - parton shower: 1 unc.
 - diff. variations obtained with MadGraph (since no NLO is available): 4 or 5 unc.
- tt+bb modelling:
 - parton shower: 1 unc.
 - NLO shape (Sherpa): 8 unc.
 - scale variations: factor of 2 up/down
 - different functional form for the scale:
 - factorisation scale (R_{Mbb}), renormalisation scale (Q_{CMMPS}) and global scale (glo_soft)
 - PDF(MSTW,NNPDF) - compared with CT10
 - shower recoil scheme (CSS_KIN)



Search for ttH production in ATLAS

Search in different Higgs decay modes ($\gamma\gamma$, bb , $\tau\tau$, ZZ and WW).
For each of them, several channels are defined depending on the top quark pair decay mode (all hadronic, lepton+jets, di-lepton).
Each channel is further divided into different analysis regions.
Very different analysis strategy.

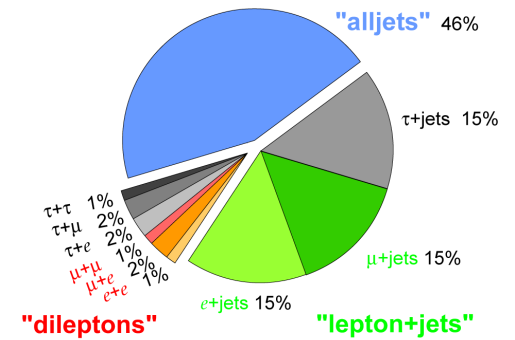

Higgs decay	Channels	Characteristics
$H \rightarrow bb$ BR=58%	l+jets (e/μ+jets)	most abundant, but overwhelmed by irreducible tt +HF background
	dilepton ($ee/\mu\mu/e\mu$)	small tt BR, only b-jets
	lepton+tau ($e\tau/\mu\tau$)	tau id. and fake estimation
$H \rightarrow \text{multileptons}$ ($WW, ZZ, \tau\tau$) BR=30%	all hadronic	multijets, combinatorics
	several signatures: 2l SS 2l SS +1 τ 3l+0 τ with $ Q(3l) =1$ 1l+2 τ with $ Q(2\tau) =0$ 4l with $ Q(4l) =0$	low rates but high purity (S/B: 0.1-4) \rightarrow good compromise, but sensitive to tt +W/Z backgrounds
	leptonic (1 or 2 l) all hadronic	clean signature and resonance peak but tiny BR
$H \rightarrow \gamma\gamma$ BR<0.23%	leptonic (1 or 2 l) all hadronic	clean signature and resonance peak but tiny BR

t-channel

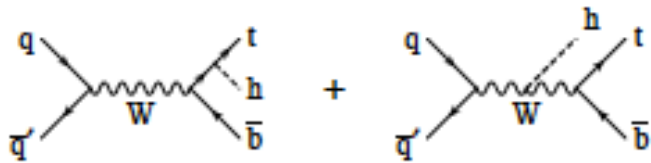
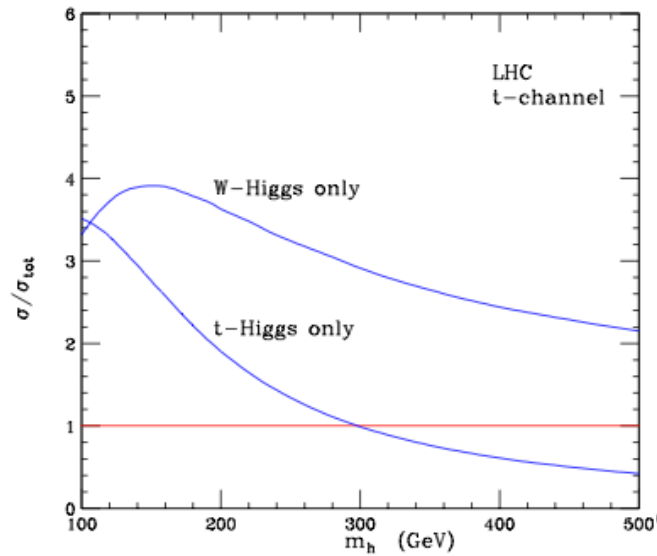

Wt associated production

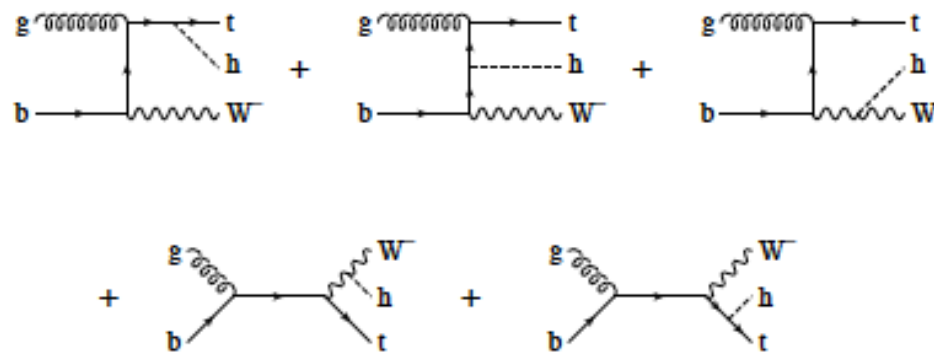
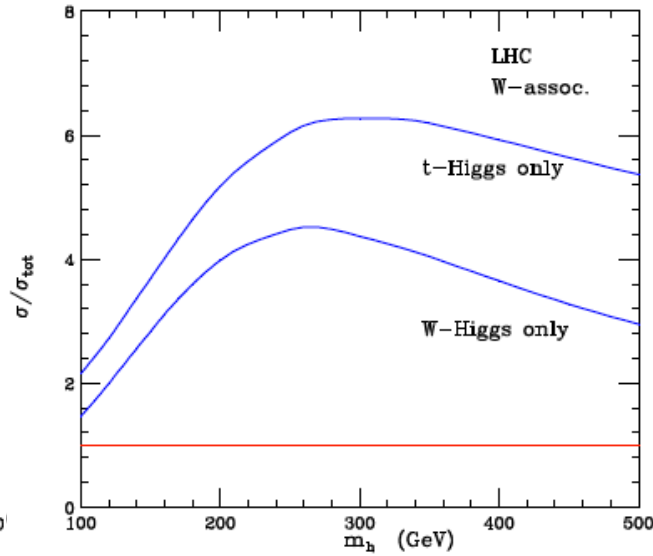

s-channel

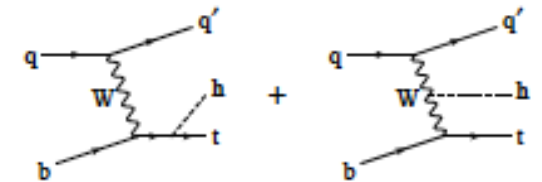
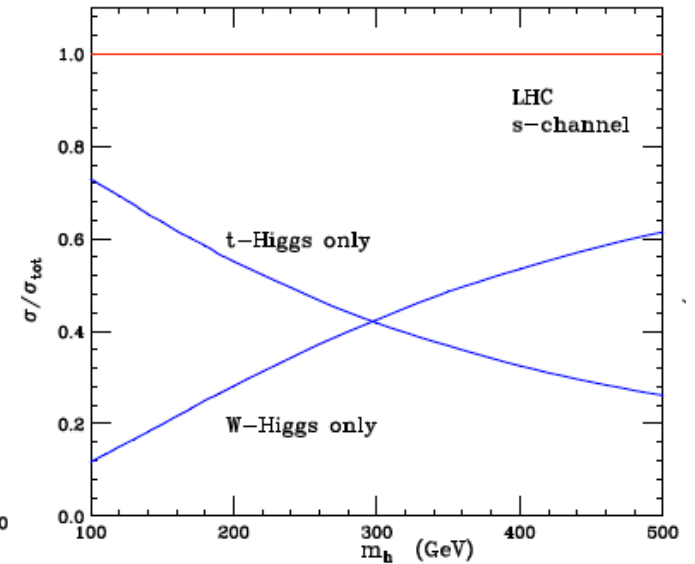

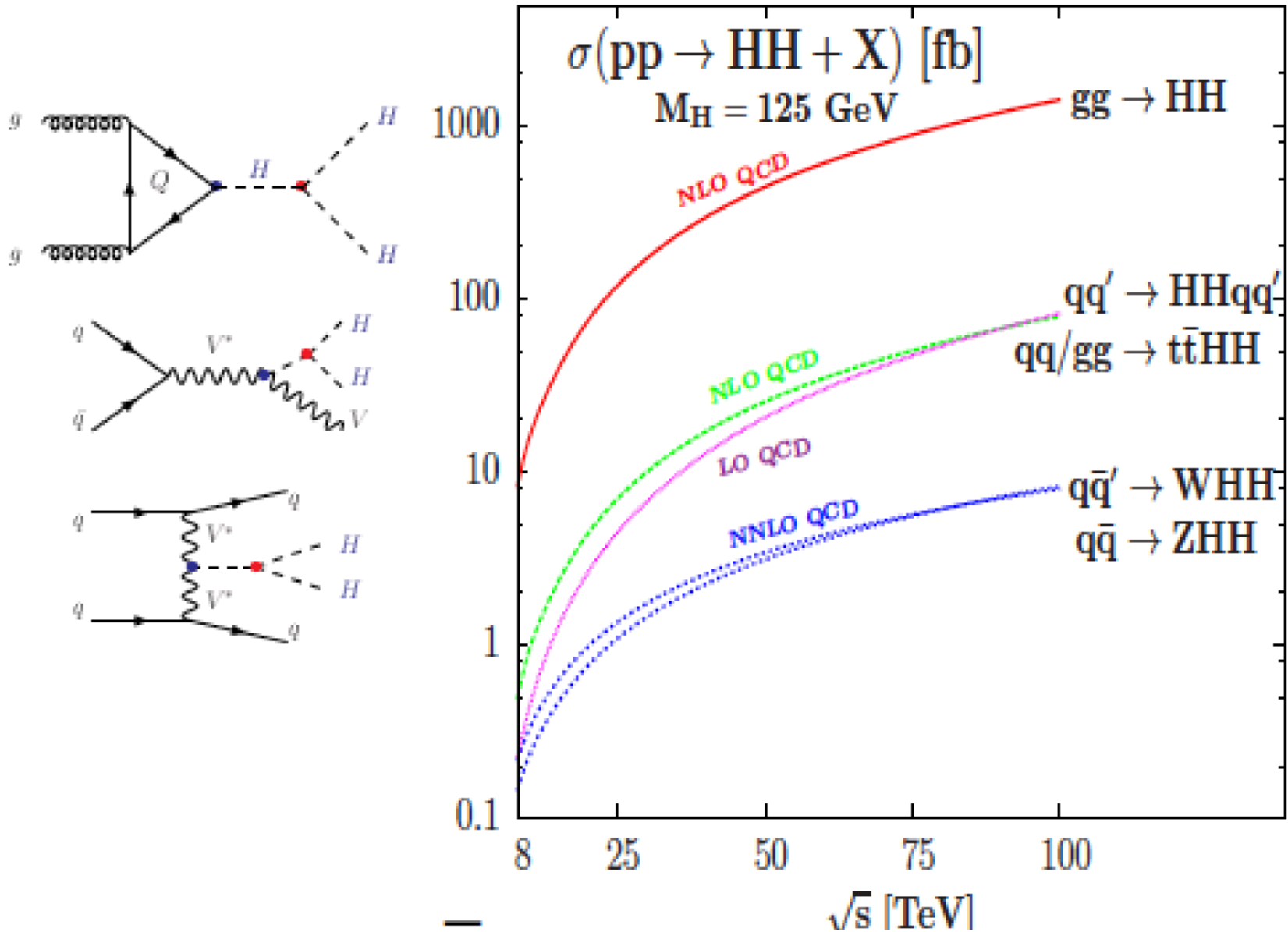

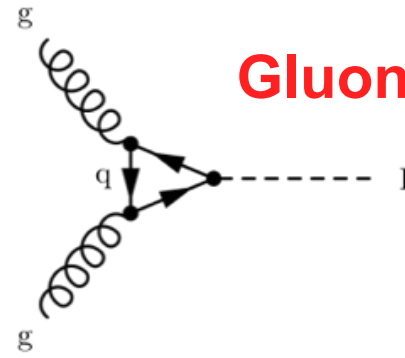
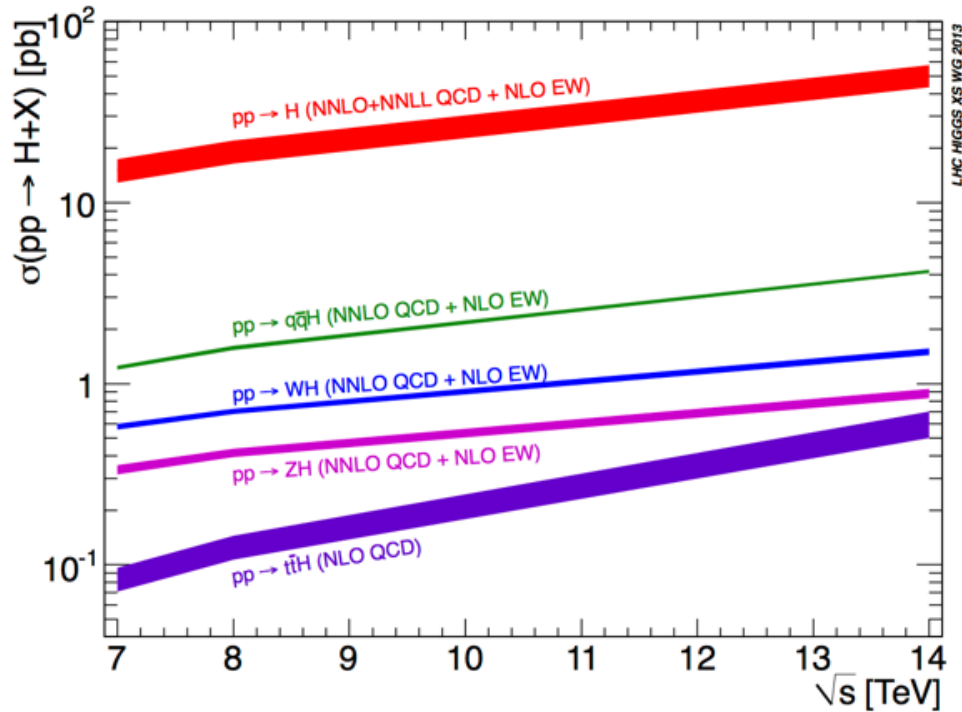

Gluon Fusion (ggF)

Largest cross-section.
Good for analysis with
already clean final states.

Vector Boson Fusion (VBF)

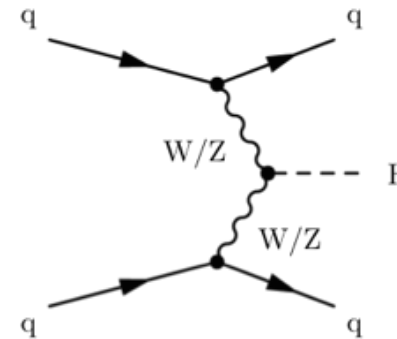

Unique signature
with forward jets.

Associated Production (VH)

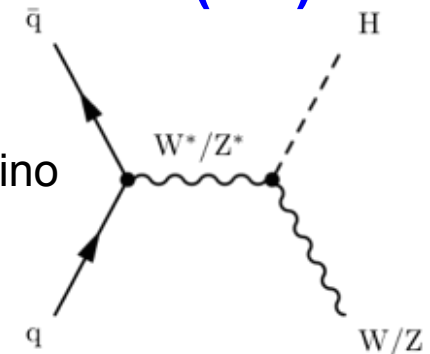

Unique signature
with lepton and neutrino
exploited in $H \rightarrow b\bar{b}$.

ttH

Unique signature with tops
exploited by various Higgs
decay modes.

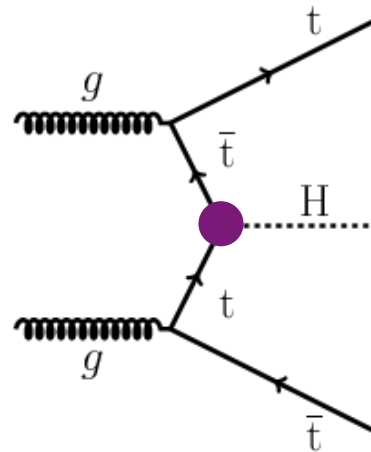



to massive Gauge bosons

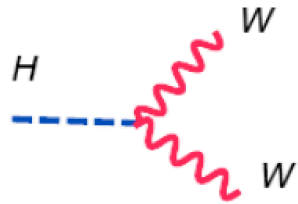

$$2i \frac{M_W^2}{v} g_{\mu\nu}$$

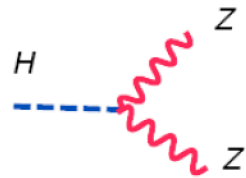

$$2i \frac{M_Z^2}{2v} g_{\mu\nu}$$

to fermions

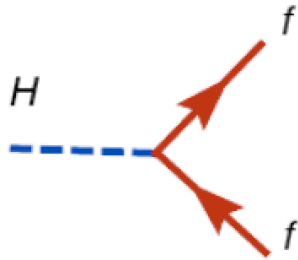

$$i \frac{m_f}{v} \delta_{ij}$$

to photons and gluons

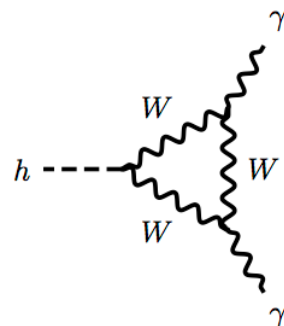
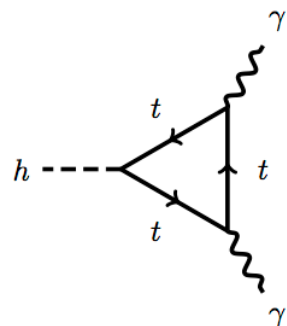

The Higgs does not couple to mass-less particles at tree-level: loop induced.

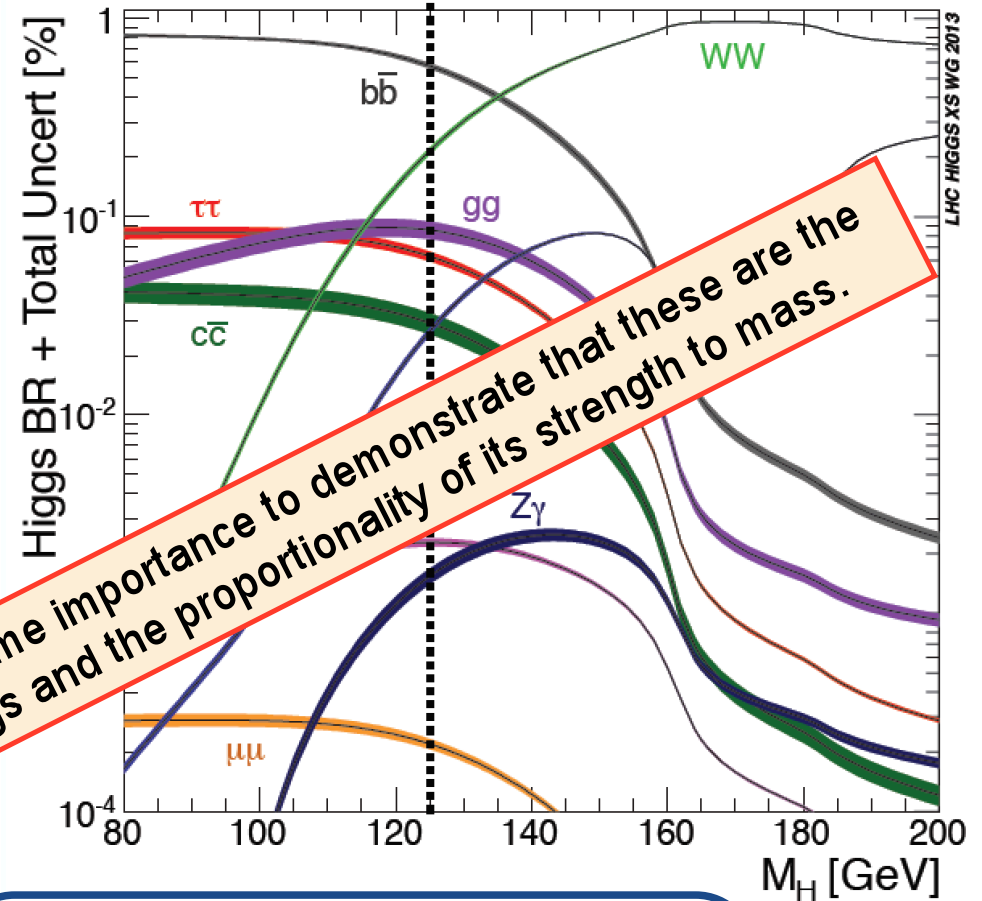

It is of prime importance to demonstrate that these are the couplings and the proportionality of its strength to mass.

SM branching ratio
at $m_H \sim 125$ GeV

$H \rightarrow bb$ 58%

$H \rightarrow WW^*$ 22%

$H \rightarrow \tau\tau$ 6.3%

$H \rightarrow ZZ^*$ 2.6%

$H \rightarrow \gamma\gamma$ 0.23%