

Finding Muons in ATLAS

Nicoletta Garelli
SLAC

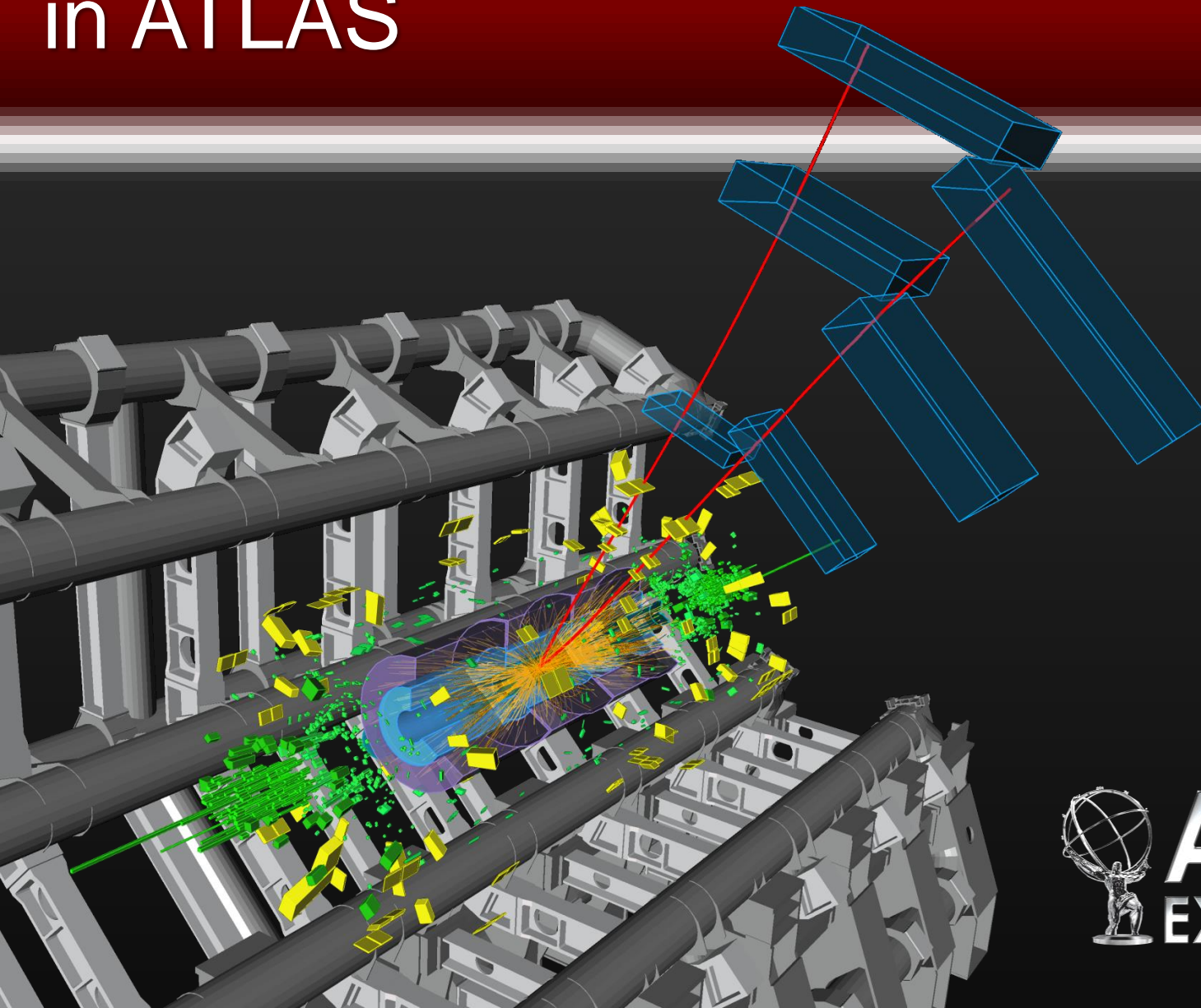

ATLAS
EXPERIMENT

Outline

- Introduction
 - Run1, Long Shutdown 1 and beginning of Run 2
- A new readout system for the Cathode Strip Chambers (CSC)
 - Limitations of the previous system
 - The RCE
 - Commissioning and first results
- Muon spectrometer run coordination
 - Highlights of LS1 activities
 - Recombine the 4 muon systems for Run 2
- Conclusions

LHC Run-1 in a Nutshell

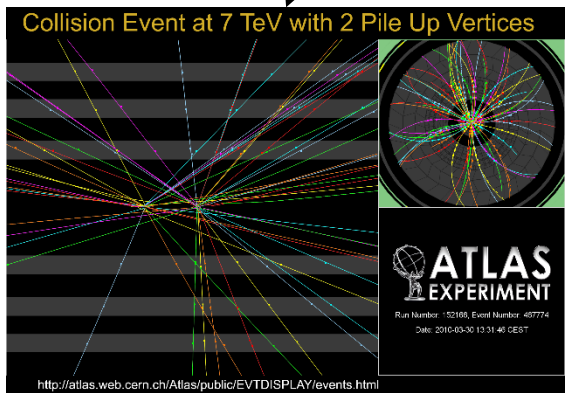
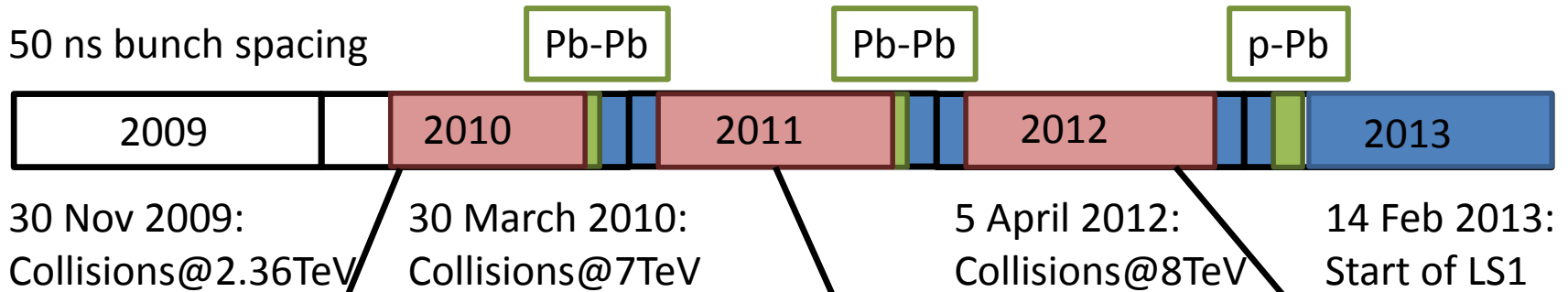

ATLAS pile-up (interactions per bunch crossing) increasing
 $O(2) \rightarrow O(10) \rightarrow O(25)$

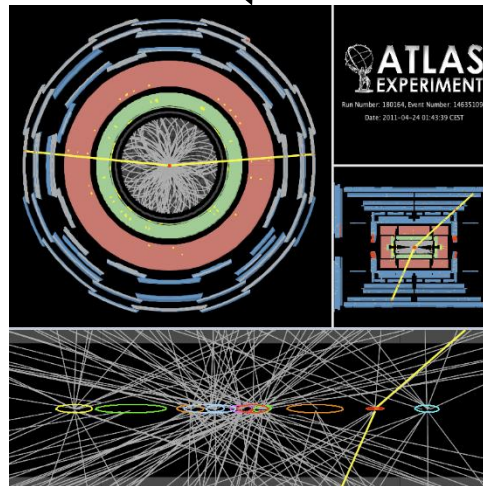

The design value was $O(20)$

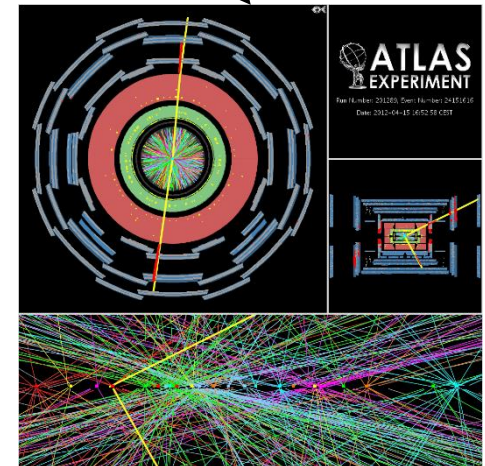

ATLAS Run-1 Achievements

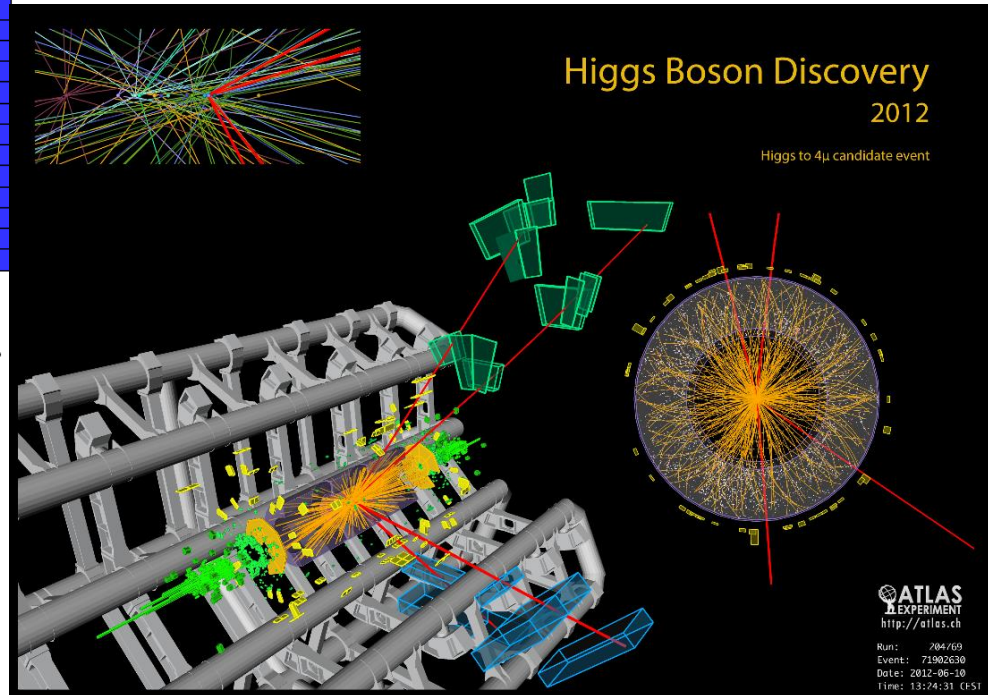
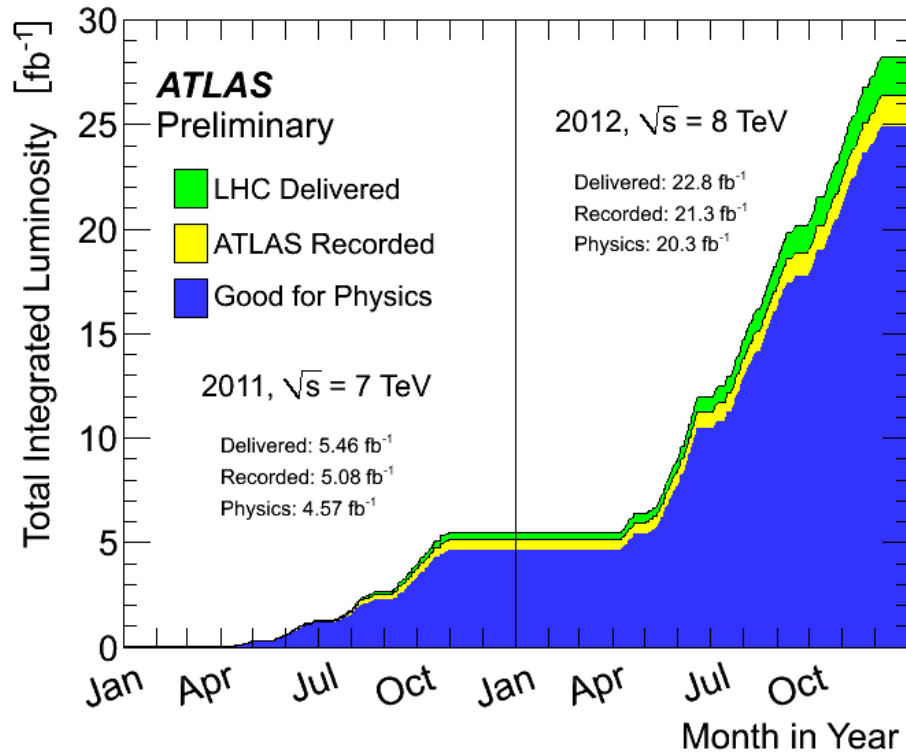

Run-2 LHC Plans & Conditions

- Long Shutdown 1 (LS1) = 2 years for upgrading the machine

Parameter	Run 1	Run 2
Center of Mass Energy	7 (8) TeV	13 (14) TeV
Bunch spacing	50 ns	25 ns
Integrated Luminosity	$\sim 30 \text{ fb}^{-1}$	$\sim 100 - 150 \text{ fb}^{-1}$
Peak Instantaneous luminosity	$7.5 \cdot 10^{33} \text{ cm}^{-2} \text{ s}^{-1}$	$1.3-1.5 \cdot 10^{34} \text{ cm}^{-2} \text{ s}^{-1}$
# bunches	1400	2550-2800
Pile-up	~ 30	~ 40

LHC Restart

- Feb 2014: ATLAS shafts closed
- Eastern April, 5th: First beams

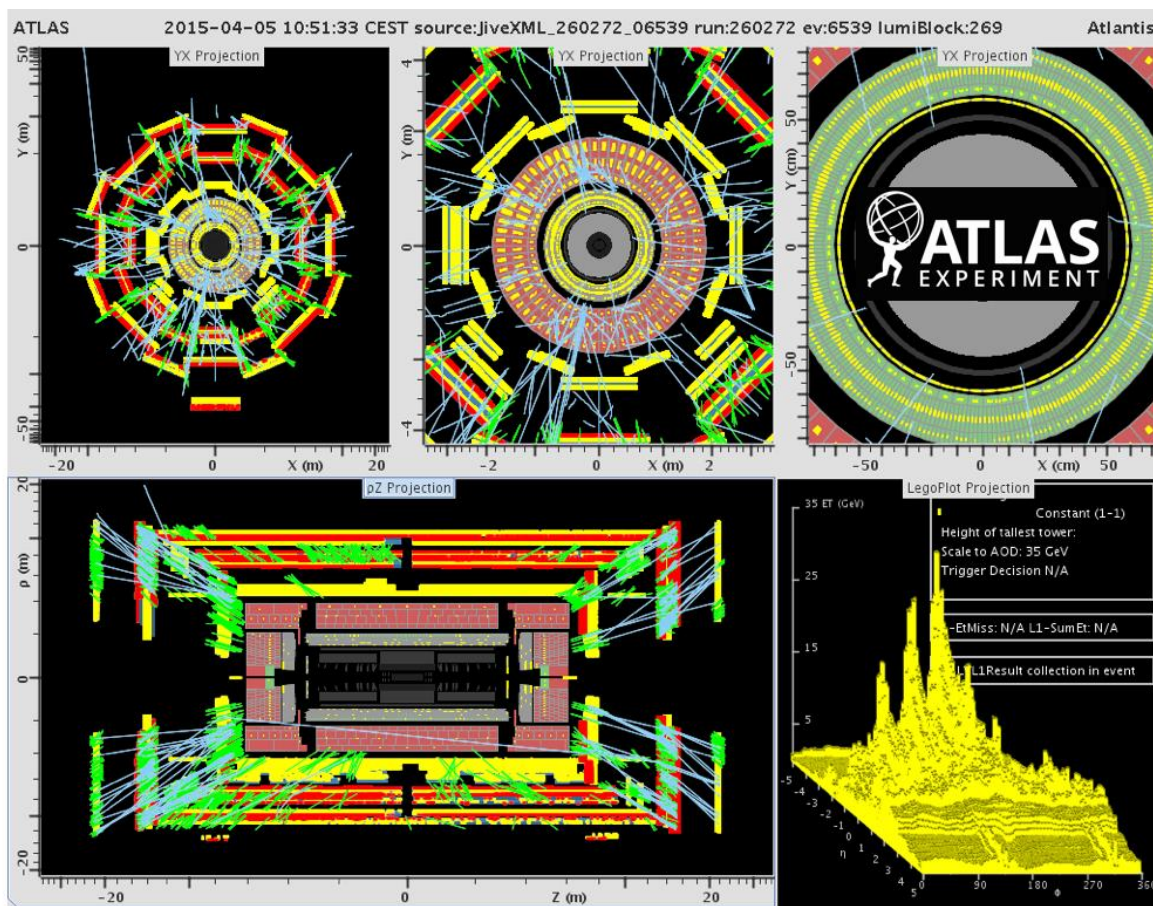

Small Note: One big wheel of the muon trigger system could not operate reliably till few hours before the first beam splashes → mistake in the configuration settings of the Trigger, Timing and Control distribution

Little example to show how important the re-commissioning phase is

LHC Schedule for 2015



We are here

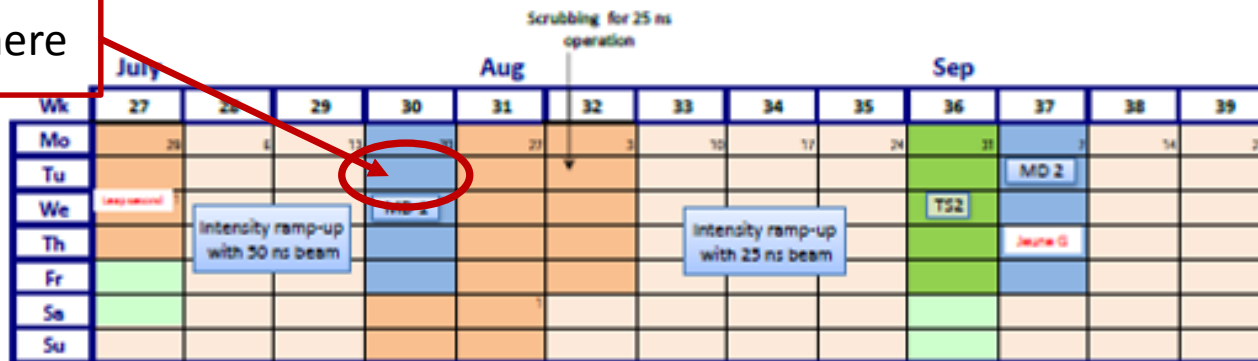

Jul 16: ~100 pb⁻¹ so far... a long way to go before stable LHC operation

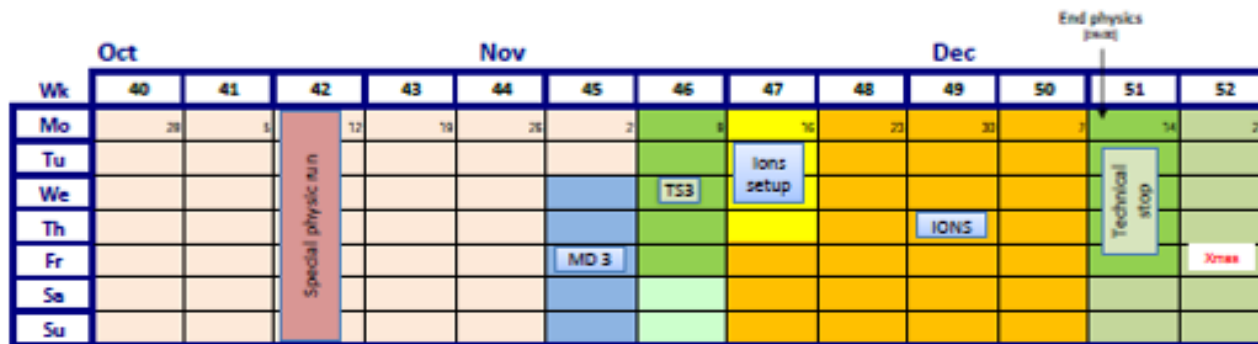

ATLAS Improvements and Additions during LS1 (best of)

- Additional fourth pixel sensors layer installed (Insertable B-Layer)
- New beam-pipe support with reduced material → reduced contribution to physics background
- Equipped and commissioned double layer RPC trigger chambers in the barrel feet region
- Repair broken front-end boards of LArg Calorimeter → back to 100% working detector
- **New readout system for small muon wheels (CSC)**

The ATLAS Muon Spectrometer

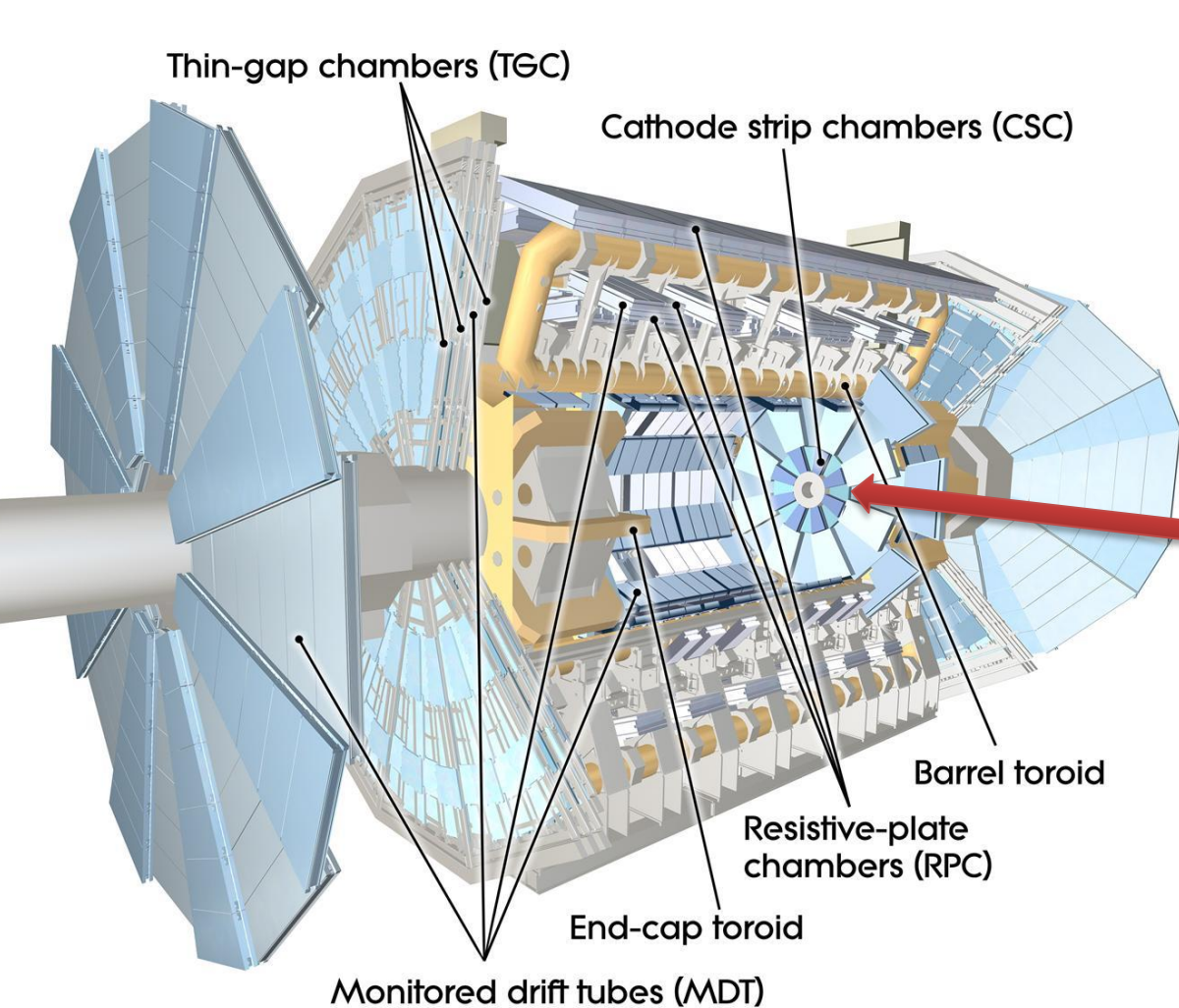

Muon Detection: charged particles emerging from calorimeters
 Muon Spectrometer: 4 sub-systems (different technologies) in air-core toroid magnet

- Trigger chambers: RPC (~600) and TGC (~3600)
- Precision chambers: **CSC (32)** and MDT (~1200)

Momentum resolution 2011

Region	σ_{ali} [TeV ⁻¹]
Barrel	0.130 ± 0.05
Endcap MDT	0.174 ± 0.05
Endcap CSC	0.146 ± 0.05

Cathode Strip Chambers (CSC)

- Located in the innermost layer of the EndCaps of the Muon spectrometer covering the region $2.0 \leq \eta \leq 2.7$
- Multiwire proportional chambers operated using Ar/CO₂ (80%:20%) at atmospheric pressure
- The position is measured by the induced charge on the segmented cathode strips by the avalanche formed on the anode wire

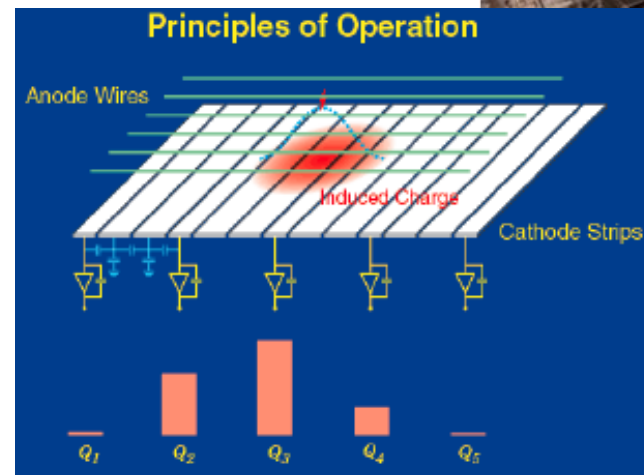

Big Data to Process

On-detector readout

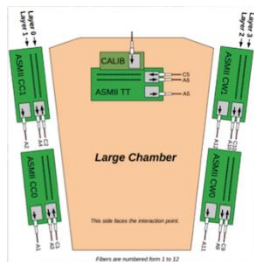

1 event = 5760 B

570 MB/s
@ 100 kHz

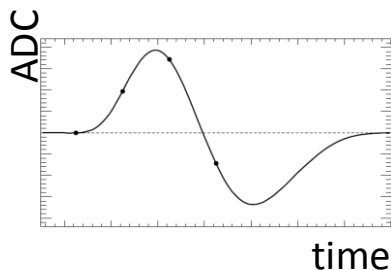

Off-detector readout



Read-Out Driver (ROD)

Max bw =
200 MB/s

ATLAS
fragment

Central DAQ and Trigger



- Despite being a small detector, CSC produces a large data volume of unparsified data
- ROD must perform the “feature extraction”: threshold cut, out-of-time rejection and cluster finding
 - Nominally process 4 time-samples (50 ns blocks) per event

The Off-Detector Electronics (Run I)

- All ATLAS detectors use **ROD** boards plugged in a VME crate
- **Common:**
 - VMEbus communication
 - Single Board Computer in each crate where common software controls and configures the system
 - Rack infrastructure (cooling, monitoring)
- **Custom**
 - Firmware
 - Interface with the central trigger and timing system. CSC used one Timing Interface Module (TIM) per crate
 - Rear modules to connect the RODs to the DAQ and Trigger system

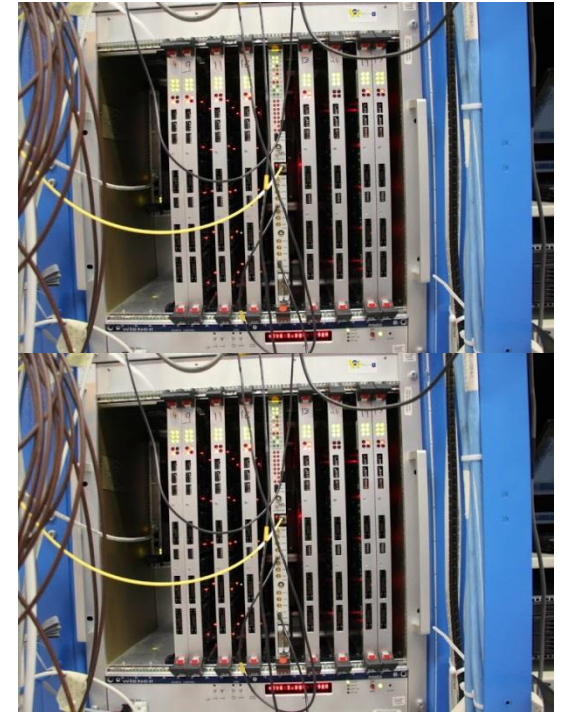

- **2 VME crates**
- **1 crate = 1 SBC, 8 RODs, 1 TIM**

Run 1 CSC Readout System Performance

- In 2008 CSC could not join the ATLAS data taking runs
 - ROD could not cope fast enough with the data processing
- SLAC team redesigned software and firmware to enable data taking in time for beam turn-on
 - Maintaining the same hardware
- CSC met design goals, but ROD limitations reached in 2012: $\sim 2\%$ deadtime with peak luminosity of $\sim 4 \cdot 10^{33} \text{ cm}^{-2} \text{ s}^{-1}$ and L1 rate of 70 kHz
- Several methods introduced to improve the situation
 - Data samples reduced from 4 to 2
 - Higher thresholds applied [ADC count should be greater than the threshold, which is configurable]

Run 1 ROD Limitations

Busy (dead-time) beyond 1% at 75 kHz, ok for Run 1, but not sustainable for Run 2

Run 1 – max performance

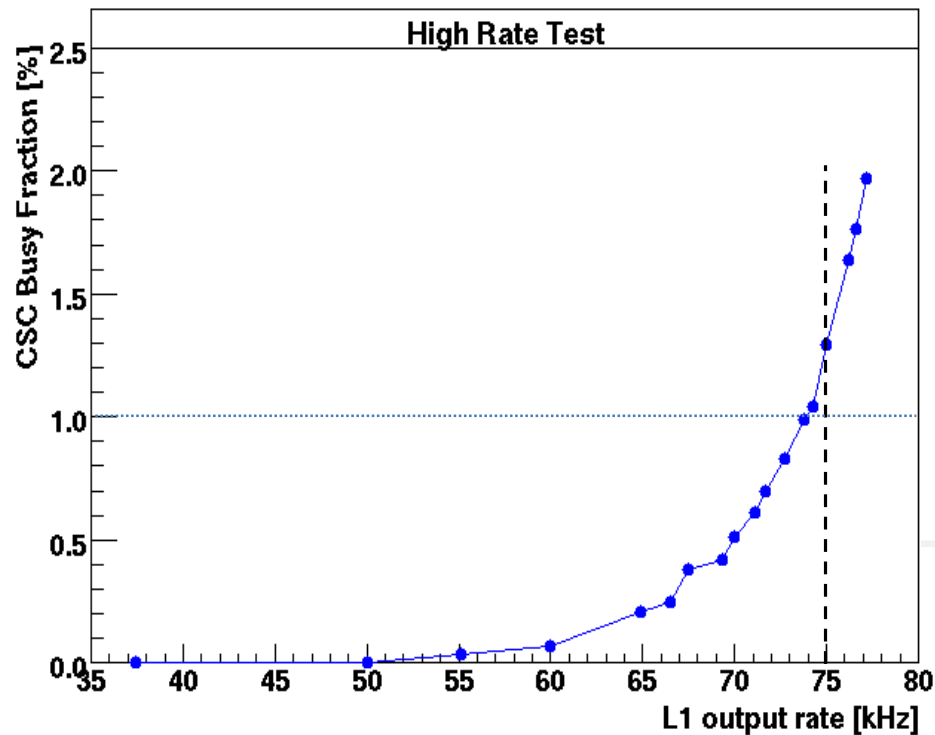

Run 2 expectations
Old ROD: Deadtime > 10%

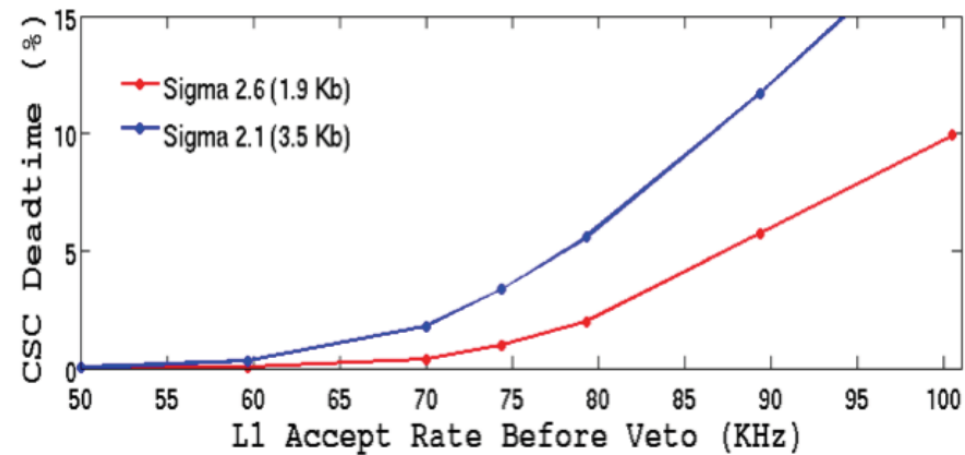

SLAC team engaged to deliver a new readout system within 2 years

The RCE: the Implementation for the CSC

- We decided to use the **Reconfigurable Cluster Element (RCE)**, a generic DAQ R&D component developed at SLAC 
 - Based on Advanced TeleCommunication Architecture (**ATCA**)
- We could have upgraded the VME-based hardware, but
 - CSC project: perfect match for the new RCE-based DAQ
 - LS1: the right moment for deploying a new system which can be used in the upgrade phases
 - Very stimulating to commission a new architecture into a well established project (the ATLAS DAQ system)

What is RCE?

- **RCE** (*Reconfigurable Cluster Element*): bundled set of hardware, firmware & software.
Physically it is a *System-On-Chip* (Xilinx ZYNQ) + interfaces + memory
- **ZYNQ**
 - New generation of Xilinx programmable device
 - Combine an FPGA with a processor, ARM dual-core @ 800 MHZ
 - Processor-centric: processor boots at reset and then configure FPGA
 - Software-centric development: user can use C/C++ for programming the processor

DPM & DTM

- RCEs housed in
 - Data Processing Modules (**DPM**): main task ‘feature extraction’
 - Data Transport Modules (**DTM**)
- 1 DPM per CSC chamber (each chamber read-out individually)
- TIM functionality replaced in DTM/DPM instead of dedicated hardware
- *Software*:
 - **RTEMS** (Open Source Real-Time kernel) for DPM
 - **ArchLinux** for DTM

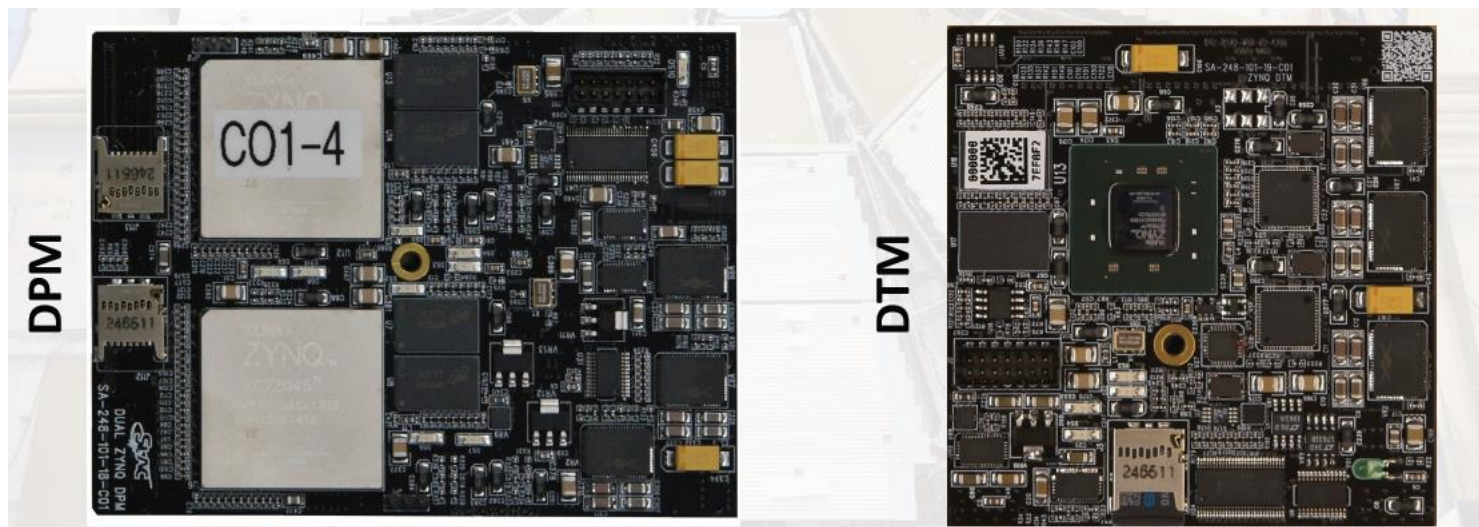

Cluster On Board (COB)

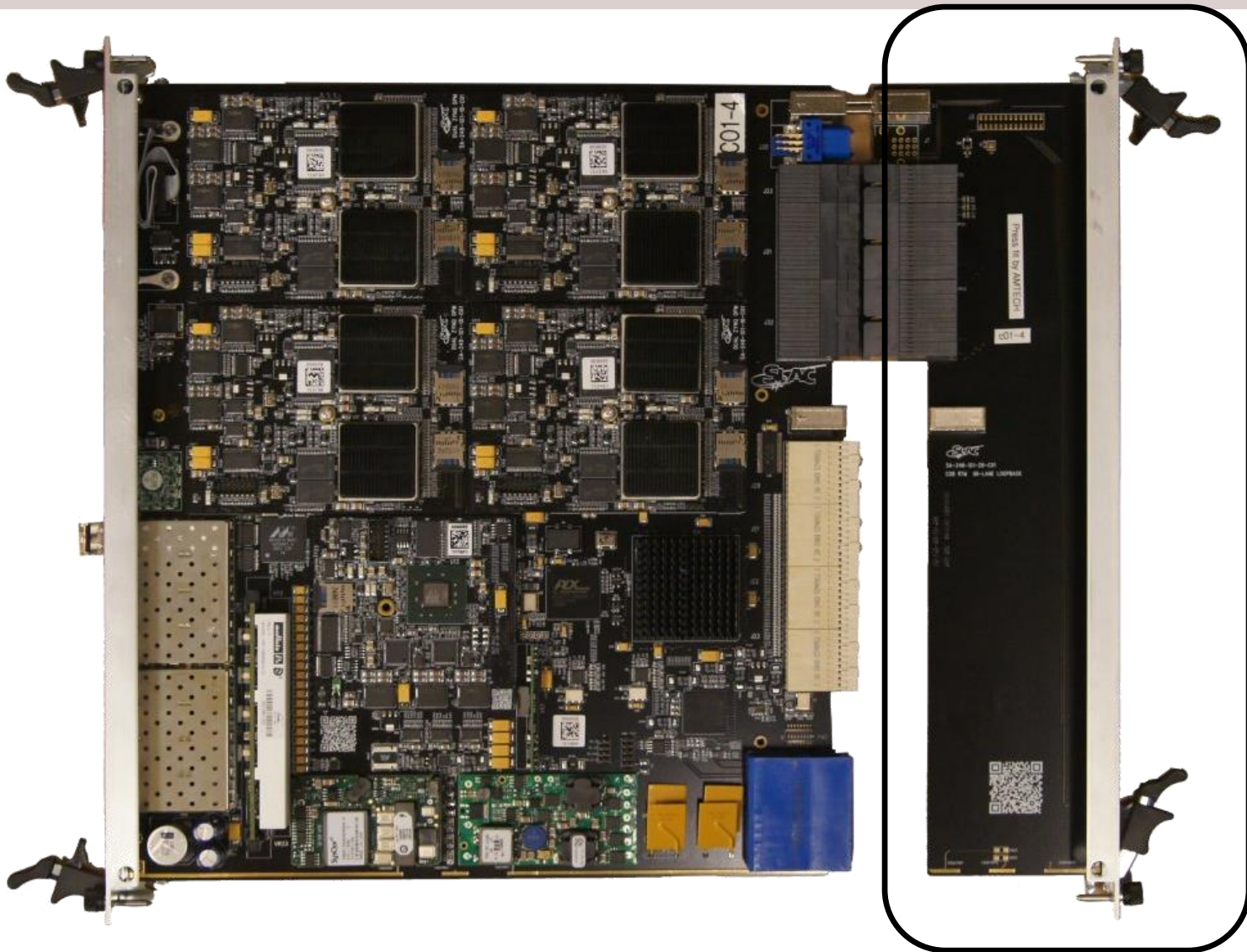

Rear
Transition
Module
(RTM)

New Hardware

- 1 ATCA shelf with 6 COBs +RTM
- 1 PC, the control processor
 - 24 core netbooted PC
- 1 Ethernet switch

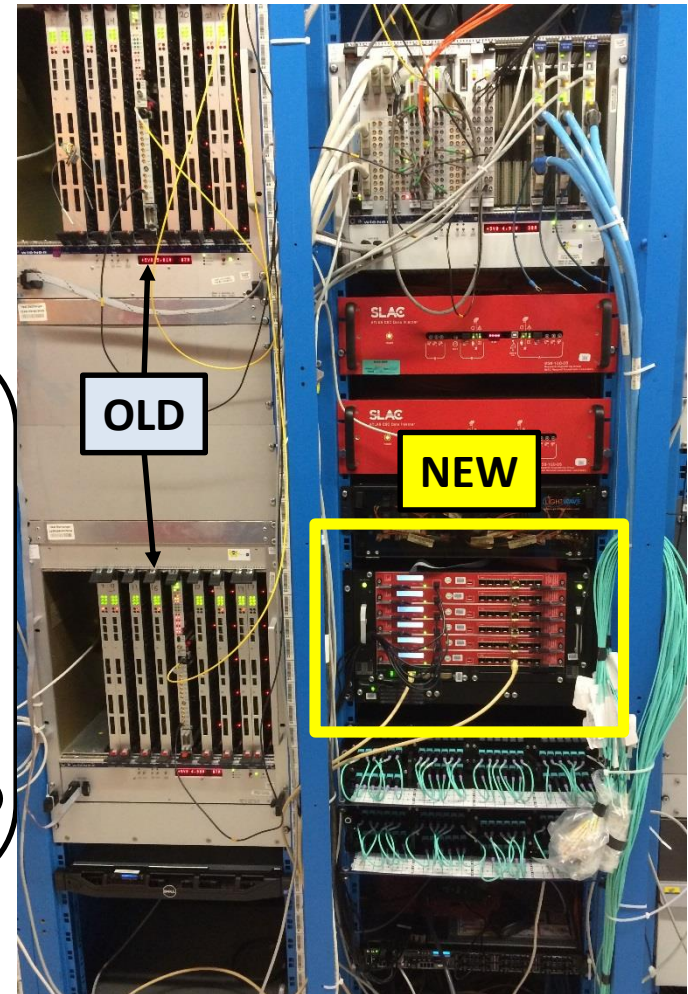
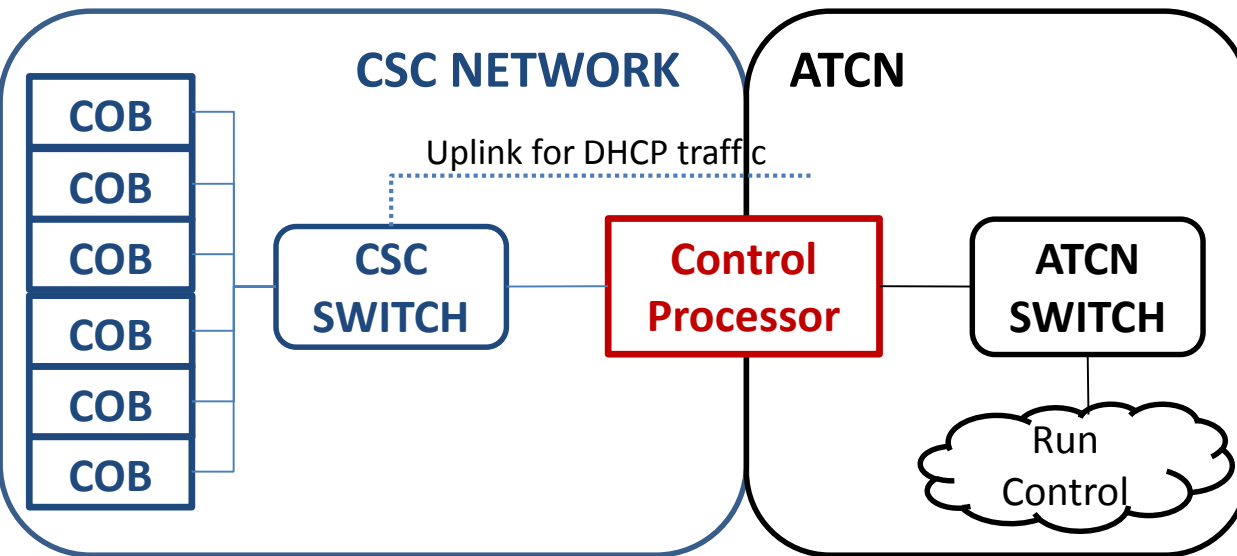

The New Rack Infrastructure

- Equipping the new rack in the service counting room was not easy
 - Establish the rack cooling distribution: ATCA shelves require horizontal cooling; VME crates vertical cooling
 - Design and install a **patch panel** for fast and safe interchange of readout systems (old and new) during the commissioning
- The ATCA shelf is monitored and controlled via the ATLAS Detector Control System (DCS)
 - Led to the development of a common interface between the ATCA and the DCS SCADA system

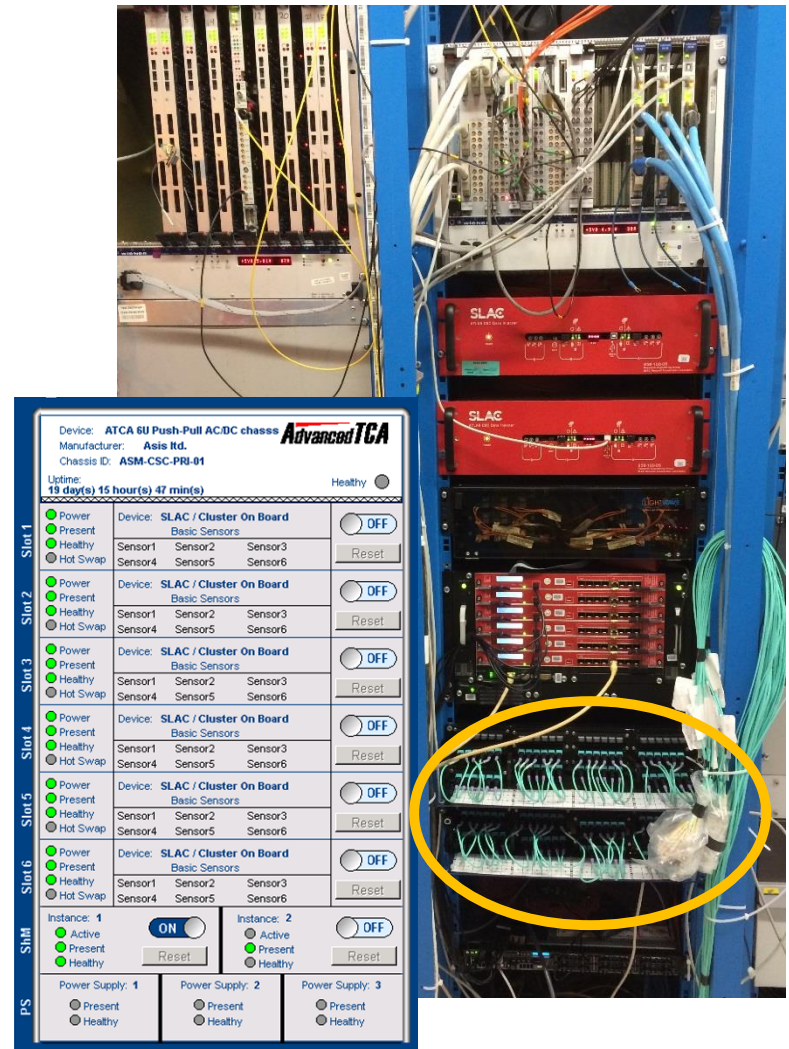

The Control Processor

- Connected ATLAS Technical Control Network (ATCN) and CSC network
- RCE are embedded system not exposed to external world and vice-versa
- On the control processor **one Readout Application per chamber** (for a total of 32) is started to initiate data taking
 - Readout Application implements interface with ATLAS run control finite state machine and sends/receives data from RCEs via network

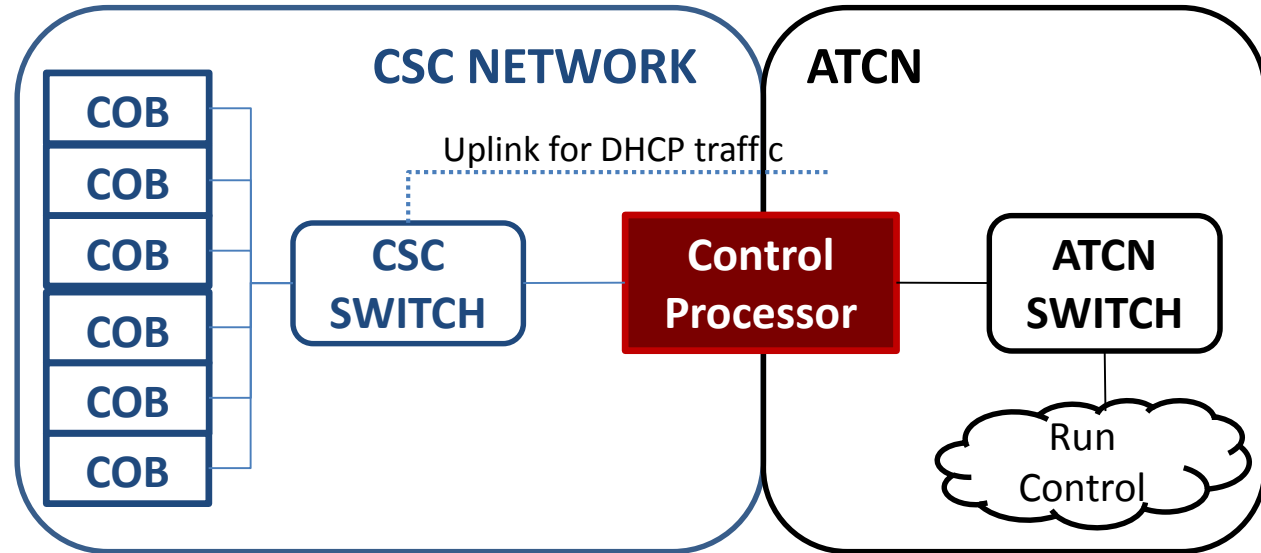

The RCE Middleware

- Establish communication protocol between control processor and RCEs via Ethernet (CSC network)
- First implementation: “VMEbus over TCP”
 - We simply ported the old interface software to TCP calls
 - System functionality proved
- We evaluated different options compatible with the network stack of RTEMS (no IPV6 support/headers)
- 1980’s technology to the rescue: **Open Network Computing (ONC) Remote Procedure Call (RPC)**
 - We just need to execute a function call over the network
 - RTEMS includes a port of ONC/RPC
 - External Data Representation for data serialization
 - We use strings as argument and return values to RPC
 - Payload is a string in JSON encoding
- New middleware in production system since May 2015

Automated Recoveries

- During Run 1 ATLAS deployed automated procedures to minimize deadtime during data taking in case of a malfunctioning component
- It is possible without stopping the run to:
 - Restart a part of the detector readout
 - Remove a component which is misbehaving
 - Eventually recover it later
- CSC had a poor implementation of the stop-less procedures in Run 1
- NOW: robust and fast recoveries with the new readout system
 - And we needed them in very few cases so far...

Detector - Counting Room Connection

- Data transferred from on-detector readout electronics via high-speed fiber optics (**G-Links**)
- Single optical fibers from chambers grouped in bundles of 12 fibers (MPO) connected to 2 patch panels on the calorimeter support structure
 - Patch panel connections very dense and difficult to manipulate
 - One broken connector after the opening/closure of end-cap during LS1
- From the patch panel, MPO fibers reach ROD system in counting room
- 320 G-links for event data + 120 G-links for configuration data
 - MPO fibers 7,8 not used

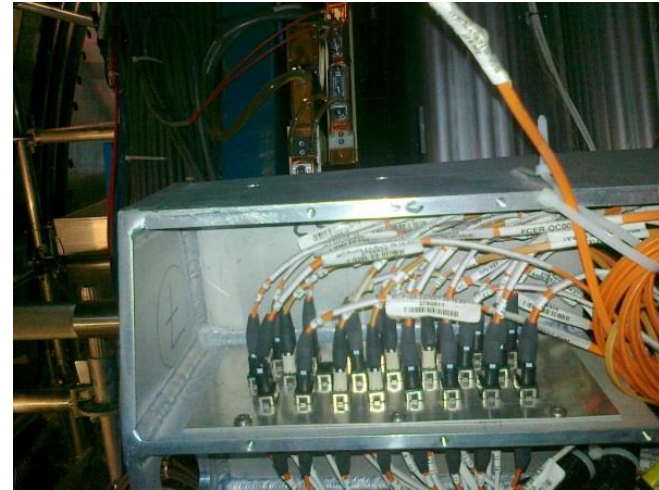

The G-link Issue 1/2

- At configure, the RCE firmware establish the G-link protocol
 - All chambers must be 'locked' to transmit data
- Some hardware problems
- But also some firmware bugs promptly fixed

25.01.2015 G-link lock status

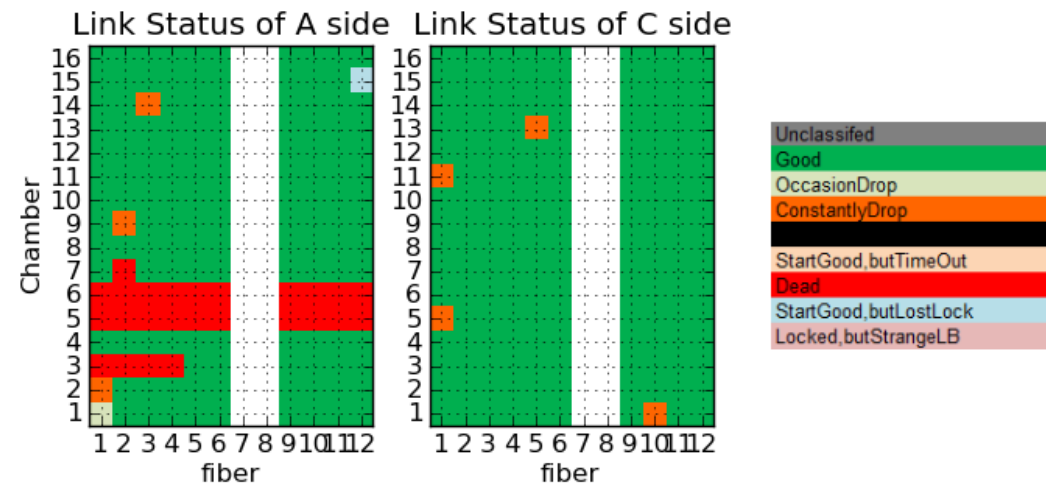

The G-link Issue 2/2

Status in March and June 2015

Still one G-link misbehaves... investigations on-going

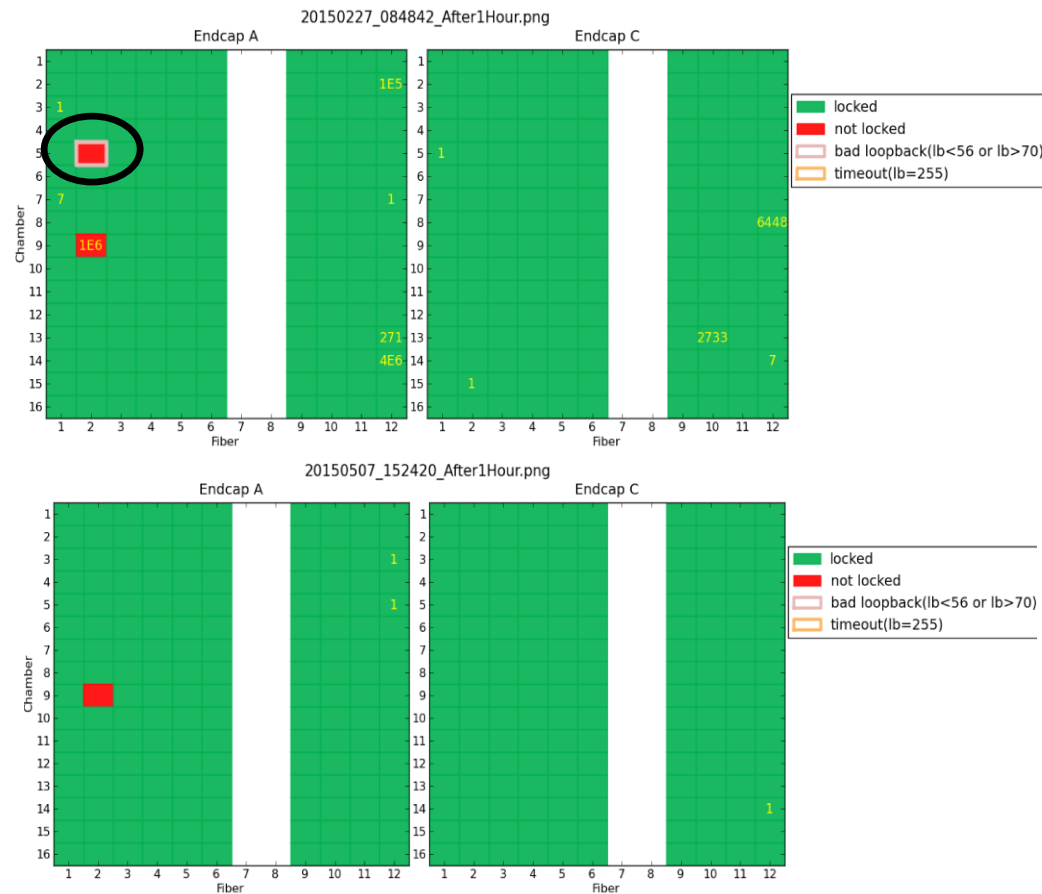

Installed splitter + patch panel to recover a single broken fiber



Some G-links become bad while running and recover few minutes later

The Feature Extraction (FEX)

- FPGA (firmware)
 - Extract from the wave-form 4 (nominal), 8, 12 (new, useful for signal tail studies) 50 ns time samples
 - Peak occurs in the second or third time sample
 - Threshold comparison: second or third time sample is compared to the threshold: if time sample > threshold → strip accepted as well as nearest strips
 - Handle also overlapping events, when an additional L1 trigger arrives within 200 ns of the previous L1
- ARM (software)
 - Receive time samples from the FEX firmware
 - Convert bit map of accepted channels to a list of clusters
 - DMA's the data from the firmware
 - Assembles time samples into events
 - Formats the event, *i.e.* the assembled time samples
 - Outputs the formatted event to the DAQ and Trigger system

The Data Reduction

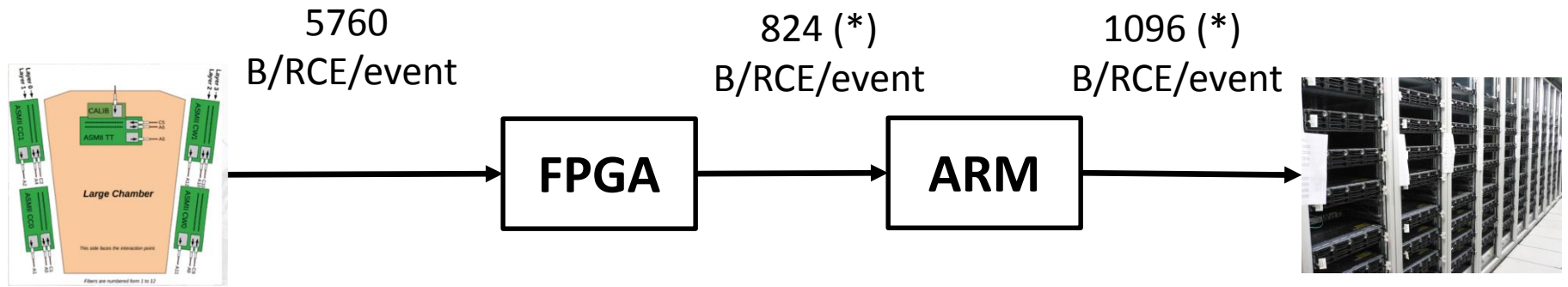

- **Each RCE is handling about 5Gbits/sec, or, with 6 active RCEs, 30Gbits/sec @ 100kHz event rate per COB**
 - This is well below RCE actual capabilities (by a factor of >10)
- **Future direction:**
 - 33% inflation of the data volume from the FPGA data to the output
 - ARM is adding control/meta information and performing a checksum
 - A new design could reduce these 1096 bytes to just around 500 bytes
- (*) Data reduction varies with luminosity (from 1/60 to 1/6)

CSC Running at L1=100 kHz

ATLAS TDAQ SOFTWARE - Partition part_CSCNRC

File Commands Access Control Settings Logging Level Help

Commit & Reload Load Panels

ERS IS DVS ED DBS LM OH

RUN CONTROL STATE RUNNING

Run Control Commands

SHUTDOWN INITIALIZE

UNCONFIG CONFIG

STOP START

HOLD TRG RESUME TRG

Beam Stable ●

Run Information & Settings

Run type: Calibration

Run number: 245400

Super Master Key:

LHC Clock Type:

Recording: Enabled

Start time: 14-Nov-2014 00:24:33

Stop time:

Total time: 0 h, 15 m, 20 s

Information Counters Settings

Run Control Segments & Resources Dataset Tags DFPANEL

Common Rates Others

IS Information

L1 HLT RE

Rate (Hz)

Time

Maximum period to plot: 0 Days 2 Hours 0 Minutes

Subscription criteria WARNING ERROR FATAL INFORMATION Expression Subscribe

TIME	SEVERITY	APPLICATION	NAME	MESSAGE
00:22:23	INFORMATION	IGUI	INTERNAL	Database commit and reload is done
00:22:23	INFORMATION	IGUI	INTERNAL	No database files to reload
00:22:18	INFORMATION	IGUI	INTERNAL	Committing database changes and reloading it...
00:21:50	WARNING	CSC-TCC-Contro... rc:ApplicationSig...		Application "CSC-TTC-RCD" on host "sbc-csc-tcc-01.cern.ch" died while exiting on signal 6. Logs are "/clients/logs/sbc-csc-tcc-01/tdaq-05-04-00/part_CSCNRC/CSC-TTC-RCD_sbc-csc-tcc-01.cern.ch_1415920701.out/err".
00:21:50	WARNING	CSC	rc:TransitionInter...	Transition "CONFIGURE" has been interrupted

Clear Message format SHORT LONG Visible rows 100 Current ERS subscription sev=ERROR or sev=WARNING or sev=FATAL

First Achievements with Cosmic Data

- Combined cosmic data taking with muon triggers
- Some events with all 8 layers hit
- Event rate $\sim 6\text{Hz}$ for events with more than 4 layers hit

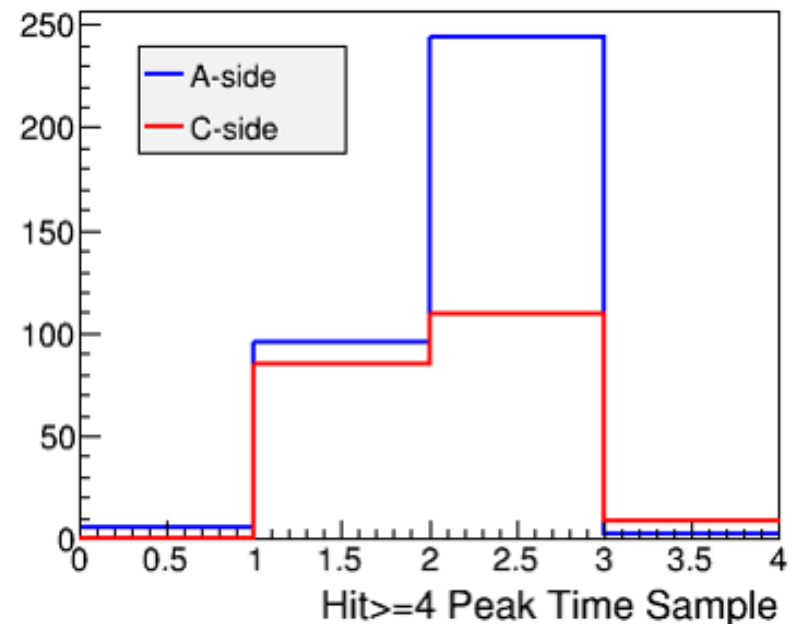
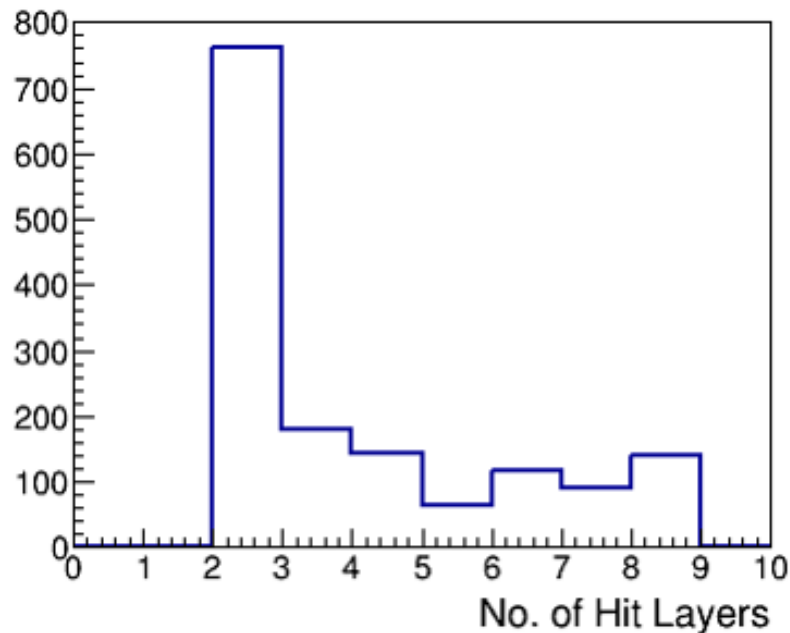

ATLAS Event Display of Cosmic Ray Event

 **ATLAS**
EXPERIMENT
<http://atlas.ch>

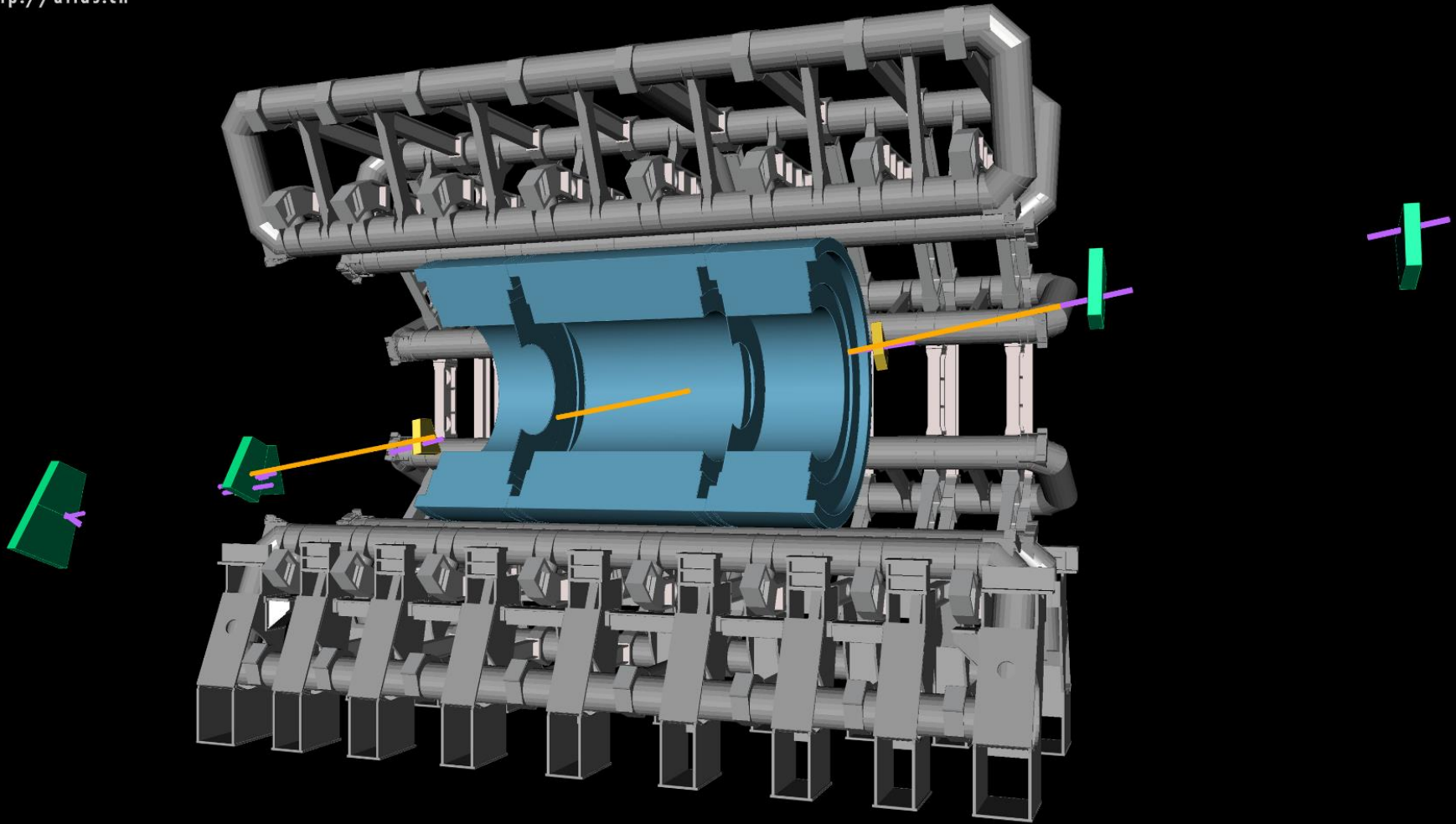

Run: 252226
Event: 3082155
2015-02-15 18:10:30 CEST

N.Garelli (SLAC)

CSC Timing

- **Beam Splash data** (left) showed the correct time difference between the two endcaps (50 ns)
- **Collision data** (right) show the same peaking time for the two endcaps

Peaking time vs Sector

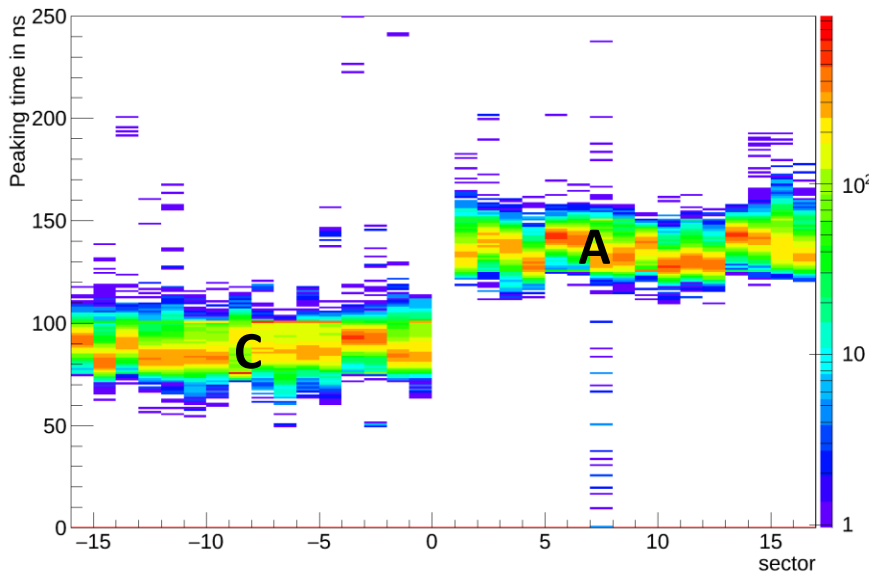

Cluster peaking time, $Q_{\max} > 10$. * F001/3.1, $60 < Q_{\max} < 2000$ counts

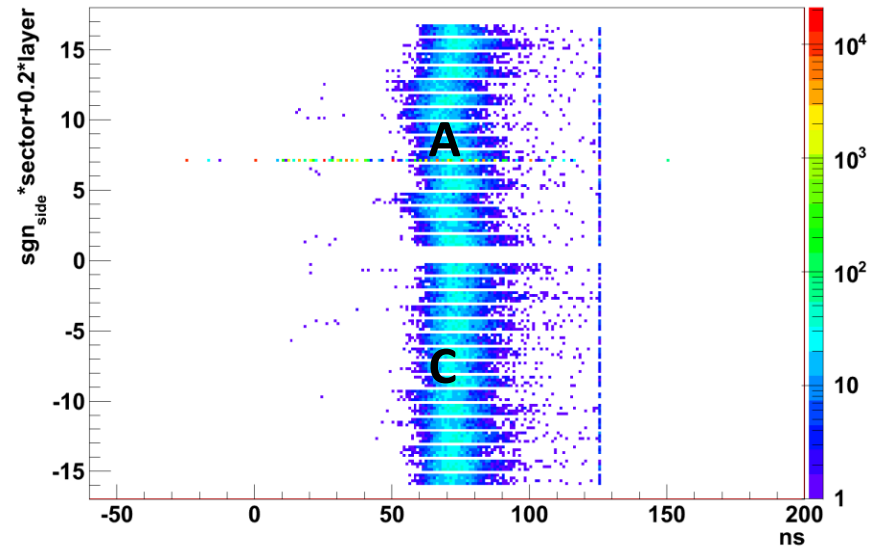

New CSC Readout: a Success

Within 2 years we put together a readout system from scratch which meets (exceeds) all the requirements



OLD ROD	NEW ROD
L1 max rate ~ 70 kHz	L1 max rate > 100 kHz
1 ROD treats 2 chambers	1 RCE treats 1 chamber
Extra board for the TTC distribution	Directly embedded distributed TTC system
Usage of bulky HOLA card	S-link logic in RCE firmware
Usage of high power G-link HDMP chips	G-link logic in RCE firmware

Work in Progress to produce a plot showing the 100 kHz rate capability at Run 2 occupancy, next seminar

Coordinating all Muon Systems

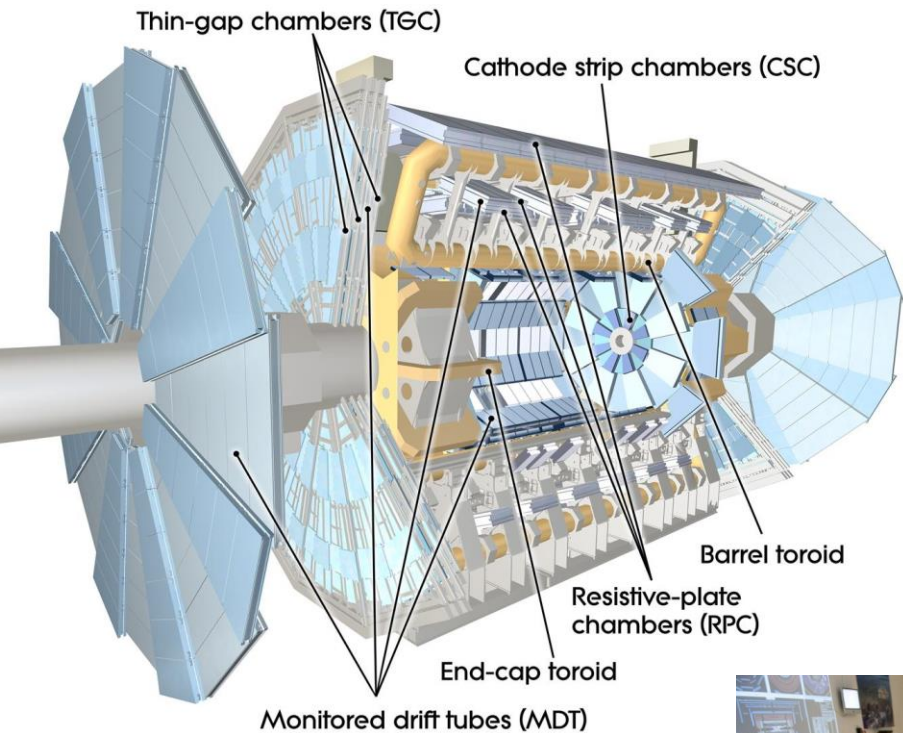

Since early 2014 I am Muon Run Coordinator ➡ also take care of all other Muon subsystems

- Completion of LS1 activities
- Ensure smooth data taking
- Arrange special runs (e.g. alignment, timing)



MDT

- MDT = Monitored Drift Tube Chambers
- Precision muon tracking detectors in both barrel and endcap
 - Working chambers close to 100%
- Endcap chambers doubled the readout rate in LS1, removing potential bottleneck

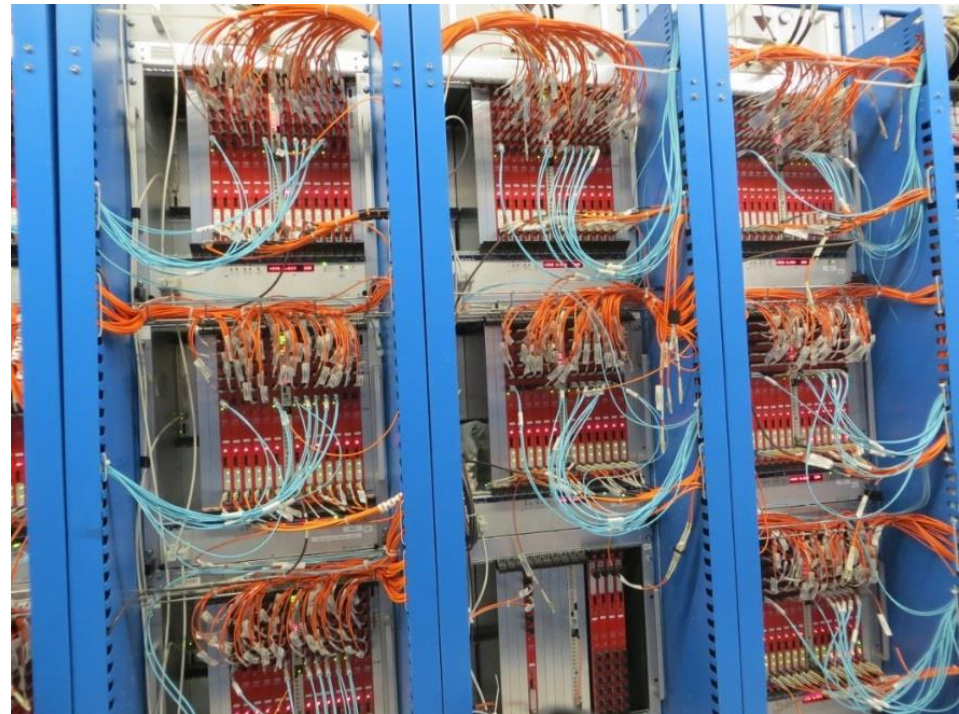

MDT/RPC Elevator Chambers

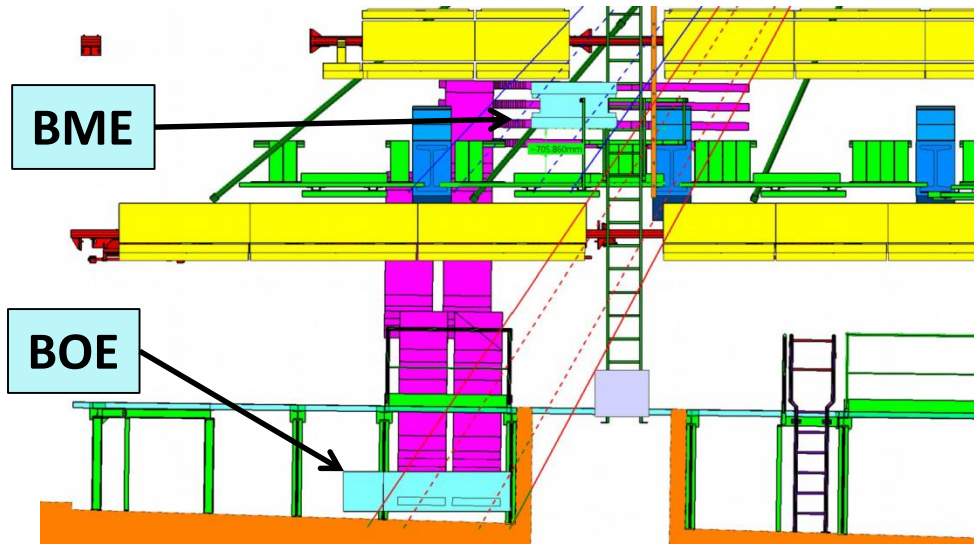

- Close coverage holes (0.9%) in sector 13
- BME = sMDT + new-type 1mm-gap RPC
 - RPC secondary readout enters MDT mezzanine boards (phase 2 studies)

- **Service connections**
 - More complicated and time-consuming than expected
- **BME status**
 - sMDT & RPC secondary readout included in ATLAS run
 - RPC chambers still to be commissioned



MDT Actual Point of Attention

- Regular noise bursts during physics runs
 - Inner barrel A sectors 6-13 (HV from the same rack)
- A month ago MDT reported noise bursts too, also seen by the electromagnetic calorimeter, which disappeared by itself
 - Inner barrel C and the Larg C side
 - All those chambers shared the HV line

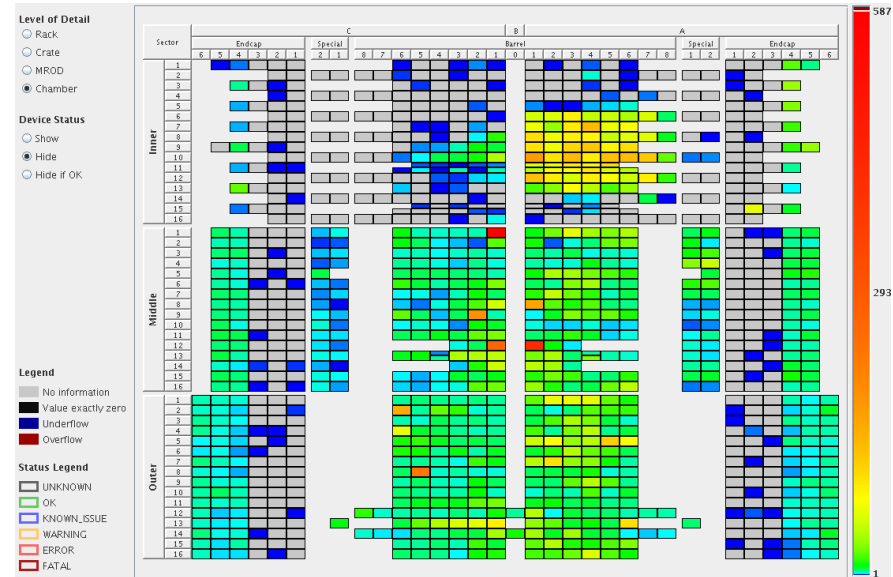
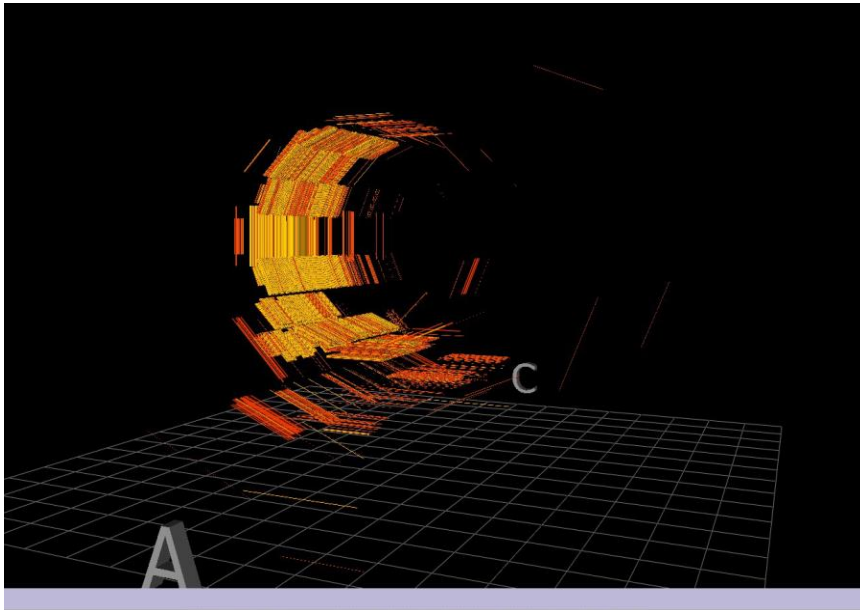

Resistive Plate Chambers (RPC)

- Barrel trigger
- **Gas inlet repair work in LS1**
 - ~400 chambers with leaks, 100 of them found in 2014
- **RPC chambers in feet sectors**
 - Two layers of RPCs in BO feet sectors (12/14), to cover holes (2.8%)
 - 20 chambers installed since before Run 1 w/o readout/trigger electronics
 - **Commissioning to be finished**

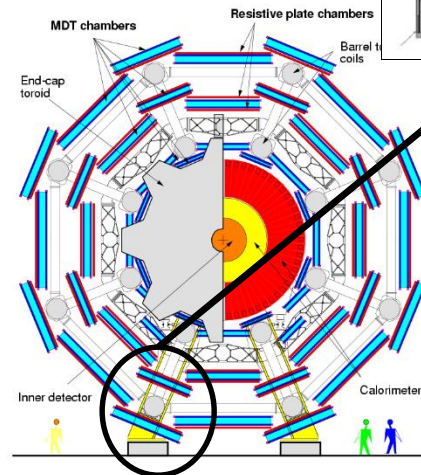
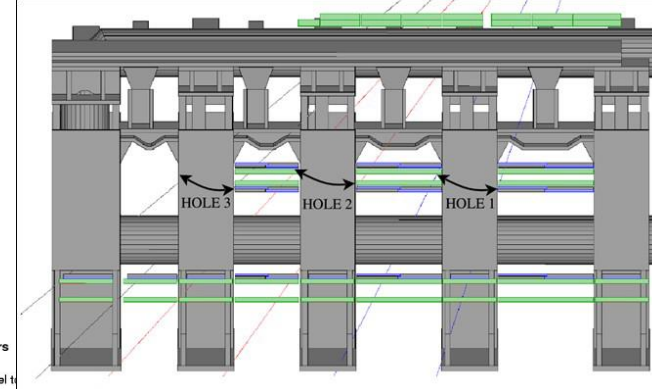

TGC Additional Coincidence

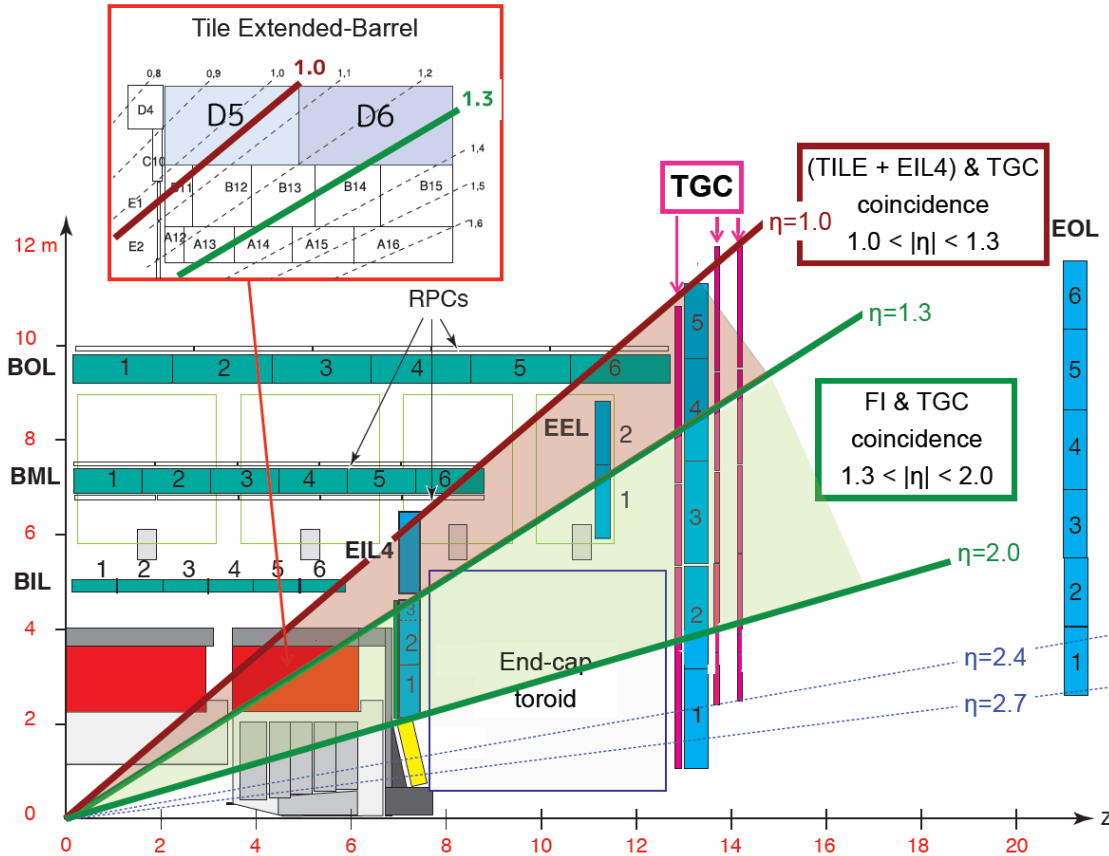

Thin Gap Chambers (TGC)
 TGC inner chambers (EI/FI) in small wheel added to coincidence logic with big wheel ($1.0 < \eta < 1.9$)

- Not available in Run 1
- New boards installed at the end of LS1
- Trigger validation on-going

Tile- μ coincidence using Tile calorimeter (D5, D6 layers) and TGC EIL4 chambers ($1.0 < \eta < 1.3$)

- Commissioning on-going

TGC Points of Attention

- During Run 1 TGC system produced large fraction of deadtime caused by series of large size of data in a short time (Noise burst events)
 - FIFO overflow
 - Timing misalignment
- Noise burst stopper for Run 2
 - Firmware to veto noise burst events
 - Still under commissioning
- Storm of corrupted fragments during Run 2 causing deadtime
 - Cause not understood
 - Burst of events?

Alignment & TGC Timing

- To bring all regions to 50 μm resolution:
 - A toroid-off cosmic run for the barrel
 - A toroid-off collision run to collect 30M-50M muons for the endcap
 - Start collecting data on Sat 4 July \rightarrow LHC problems \rightarrow ATLAS decided to postpone it
- In the shade of the attempted endcap alignment: TGC time scan

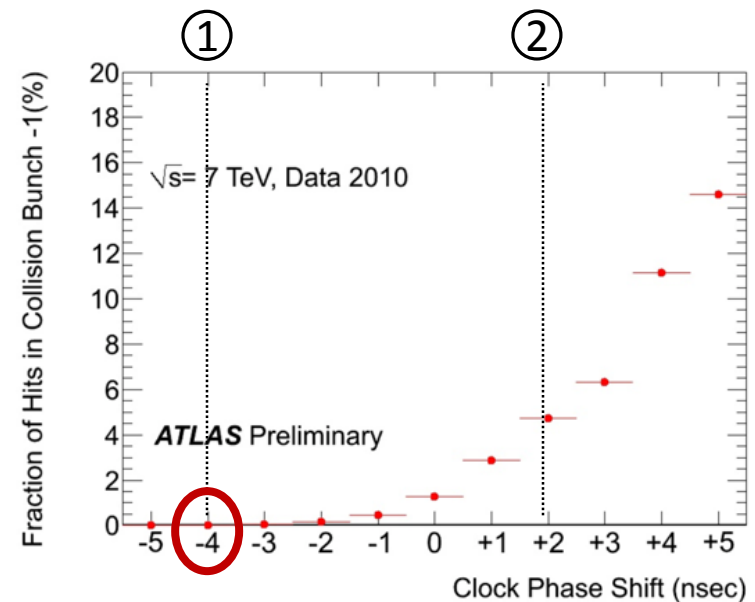
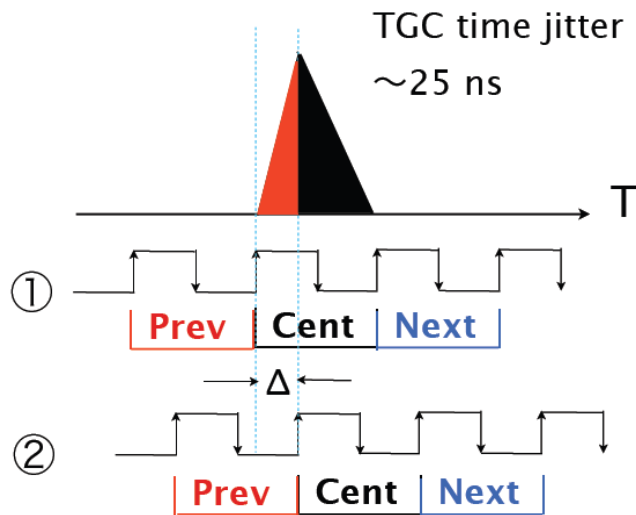

We keep Run 1 settings

Efficiency

Muon reconstruction efficiency measured using $Z \rightarrow \mu^+\mu^-$ decays

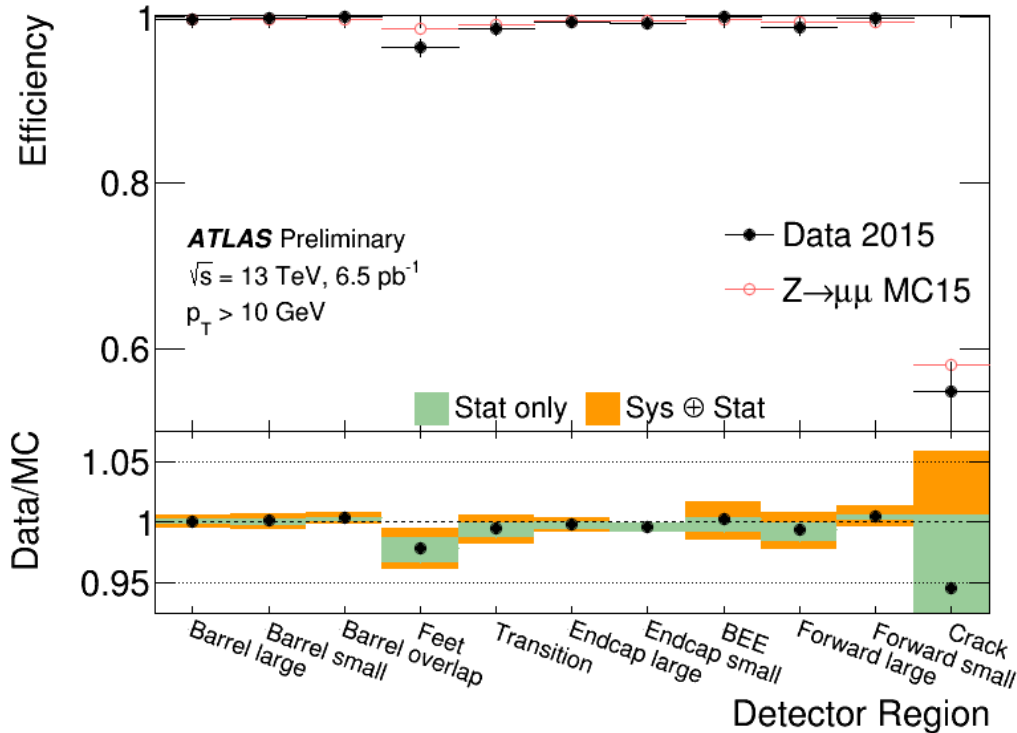

- TGC shows a very good data/MC agreement
- RPC is $\sim 10\%$ less efficient in data
 - 3% feet /elev. chambers, 4% timing, 3% to be understood

First Run 2 Data

Dimuon invariant mass distribution for oppositely charged, muon pairs with $p_T > 4$ GeV and $|\eta| < 2.5$ GeV

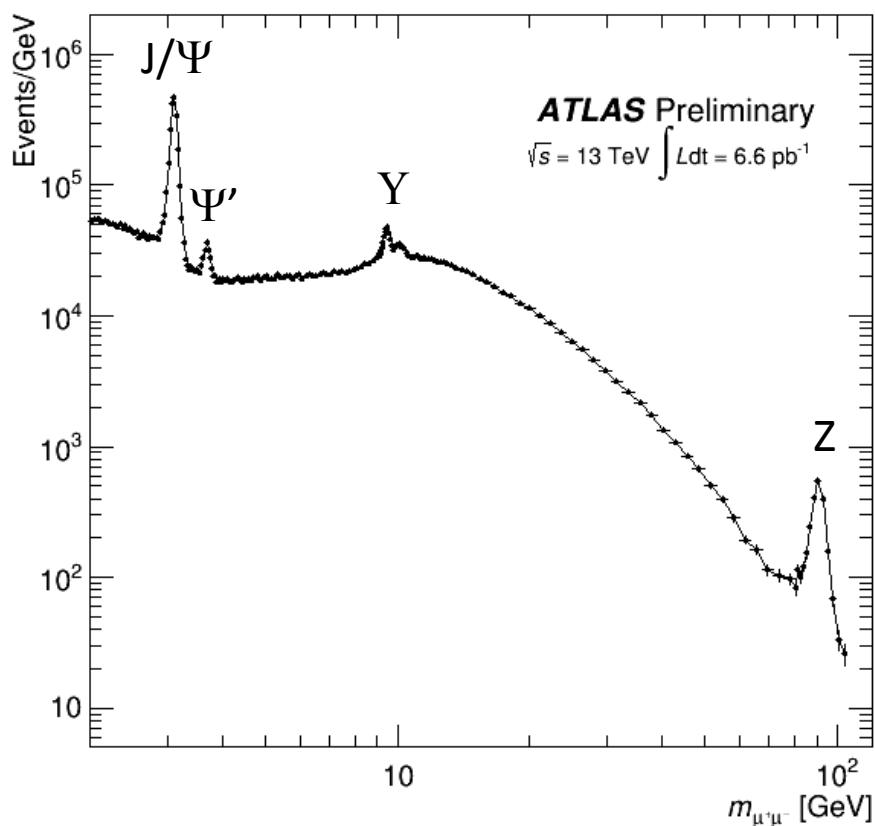

J/ Ψ mass. MC calibration done with Run 1 data \rightarrow good agreement with data

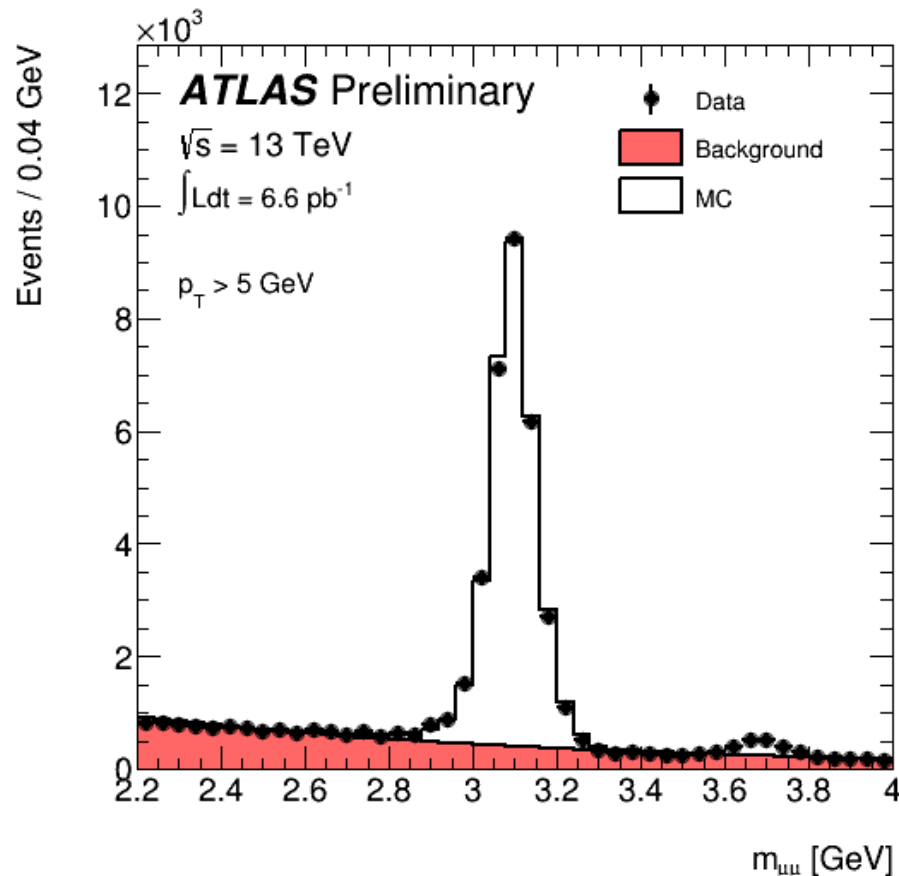

Conclusion

- During LS1 the ATLAS experiment carried on many upgrade activities to face the challenge of Run 2
 - Higher beam energy, higher trigger rates
- **The new readout system for the small muon wheels (CSC) was one of the critical update and it has been successfully developed, deployed and commissioned**
 - Work well and reliably at 100kHz L1 rate
- All four muon systems had a dense program during LS1 and some items are still under final commissioning
 - Work on going to consolidate the new additions
- **Muon Spectrometer getting ready to 25 ns LHC operations**

THANK YOU



Run: 267639
Event: 9576943
2015-06-14 08:51:30 CEST

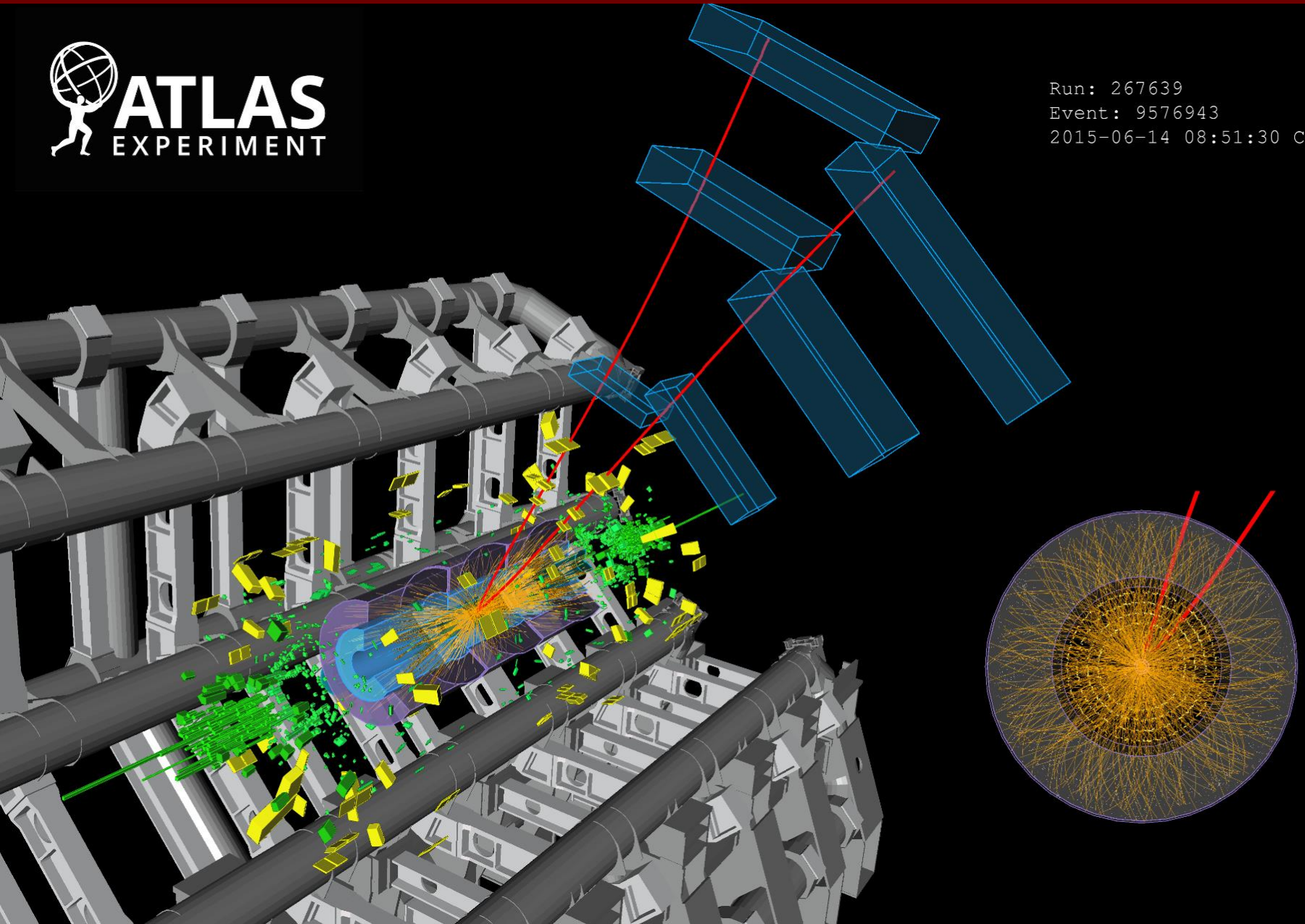

BACKUP

Naming Convention

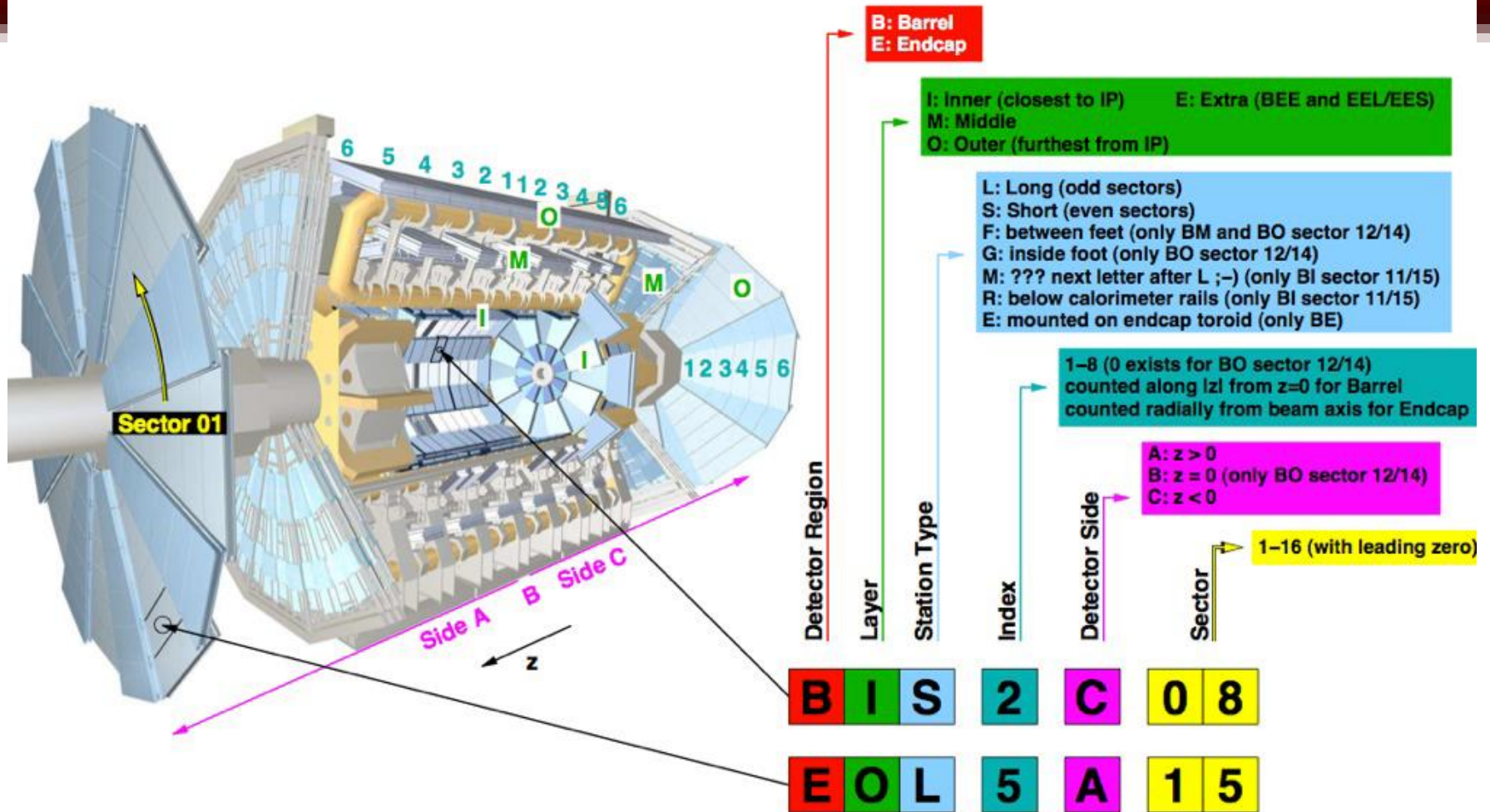

- All MDT chamber names consist of 7 characters
- Chambers with same station Index (and same side) form a projective tower = crossed by tracks from the IP. Losing eg 2 MLs in the same tower = hole in coverage/momentum rec.

Link to Offline Processing

- Each CSC chamber is now read out individually
 - Additional flexibility for the system
- The event format is close to the old CSC format
 - Contains the data (**RPU block**) of **one chamber** instead of two due to the new doubled ROS links (16 fragments → 32 fragments)
- A new, disjoint set of source IDs (to distinguish from the old data)
 - adapted ROD decoder and bytestream converter
- All changes implemented downstream (HLT)
 - Region selector, cabling map, geometry, etc.
- All successfully tested at the end of 2014