

Advanced Manufacturing for RF Sources and Systems

Julian Merrick

Feb 11, 2026

What defines an 'RF Source'?

RF Sources turn electrical power into RF power in a usable format.

- Vacuum Electronic Devices (VED)
- Solid State Power Amplifier (SSPA)



VED and Modulator



SSPA System

E. Montesinos

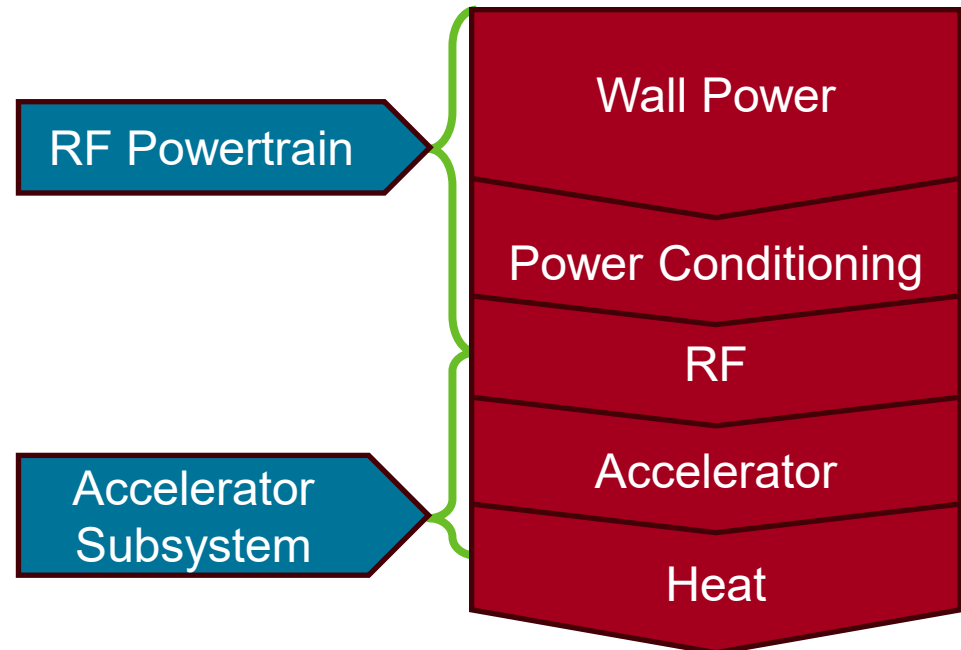

RF Powertrain: VED and SSPA

An accelerator's effective RF source is more hardware than just an SSPA, klystron or magnetron

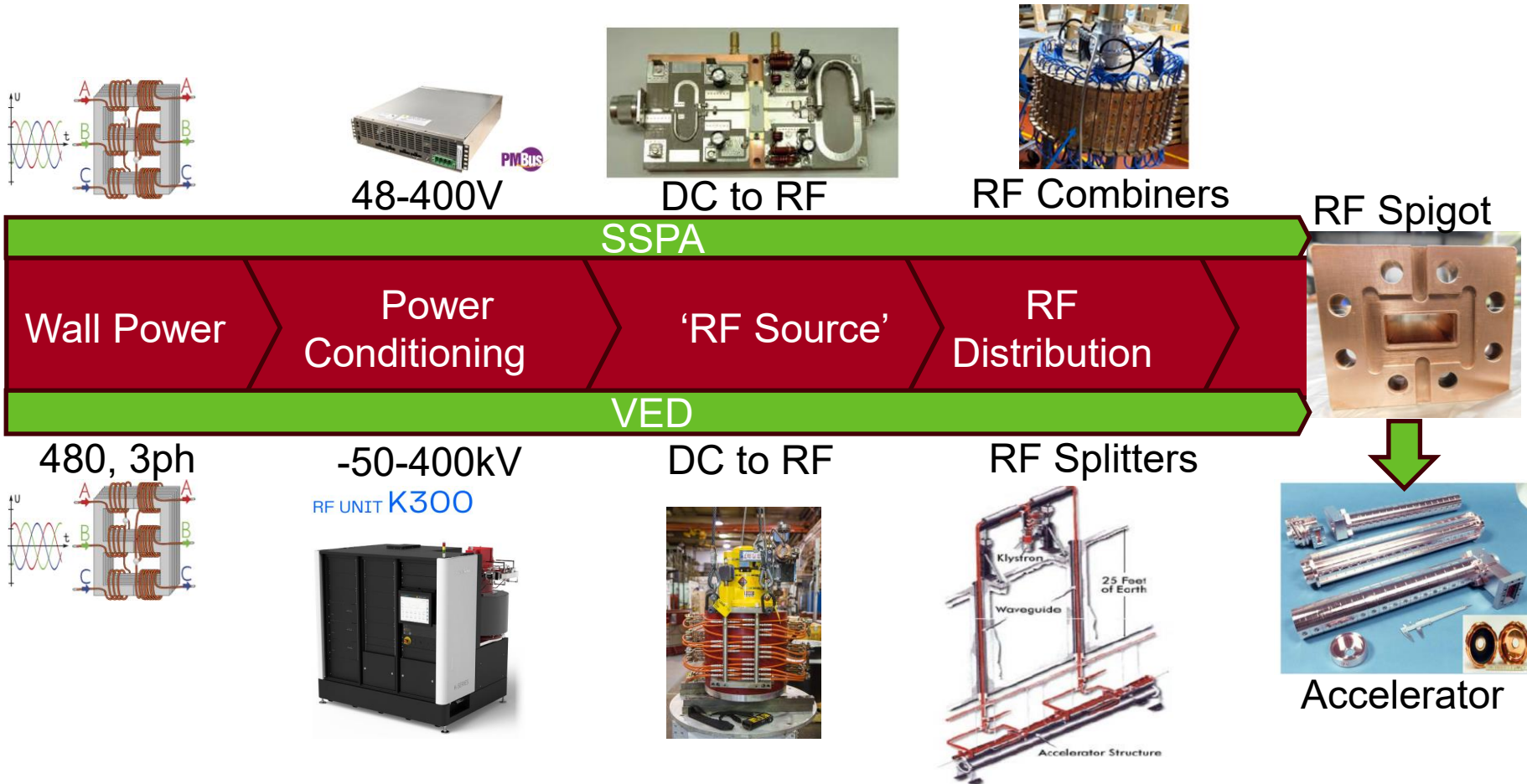

VED vs SSPA Performance Differentiation

VED have higher peak power capabilities, traditionally used as the RF source for NC accelerators

SSPA are better suited for lower peak power applications operation synchrotron, and SC applications

Form, fit ,and function replacement for RF systems must take the entire powertrain into account. If substantial facility modifications are required that can be a non-starter for adopting new technologies.

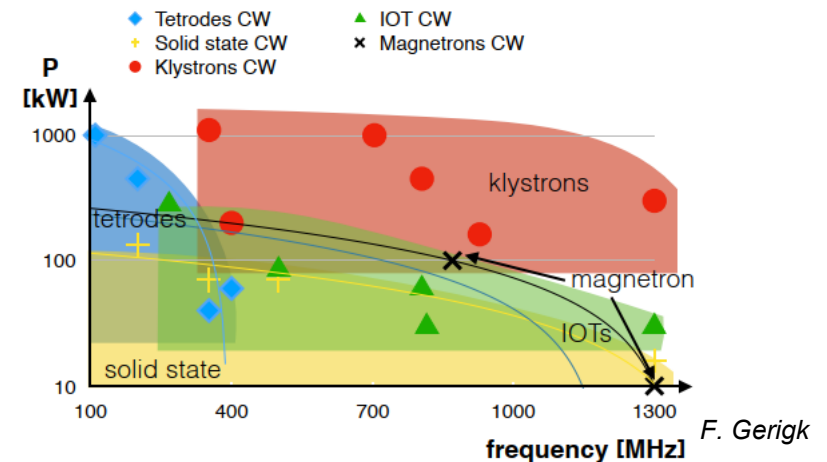
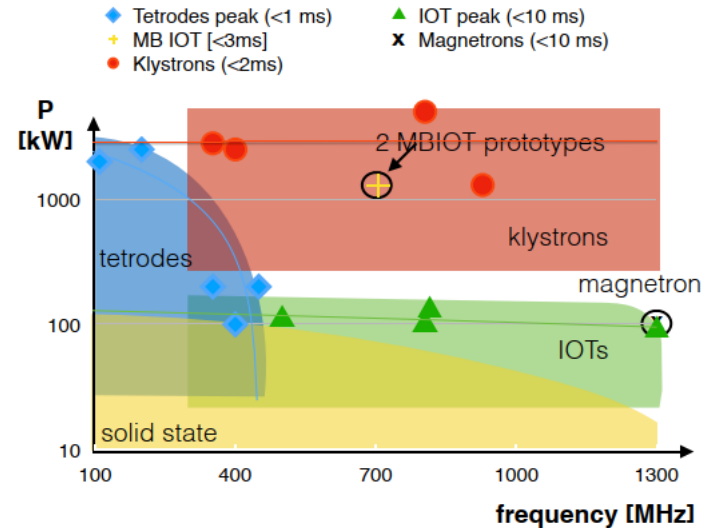

Peak Power vs Frequency (Top)
CW Power vs Frequency (Bottom)

Supply Chain Consolidation

VED Suppliers

- Canon
 - e2V
 - MPP (CPI)
 - Stellant (L3)
- } TransDigm Group

SSPA

- Many manufacturers, but few manufactures of turnkey accelerator class systems

High power VED manufacturing is a niche industry, now with a single domestic supplier. Within that market accelerator class RF sources are specialized (very high power, low bandwidth)

Legacy supply chains have consolidated or pivoted to serve other industries.

- Cathodes
- Windows
- Specialty/Rare Earth Alloys

ORNL/TM-2025/4359

Oak Ridge National Laboratory Summary Report of the First Long-Pulse and CW Klystron Workshop

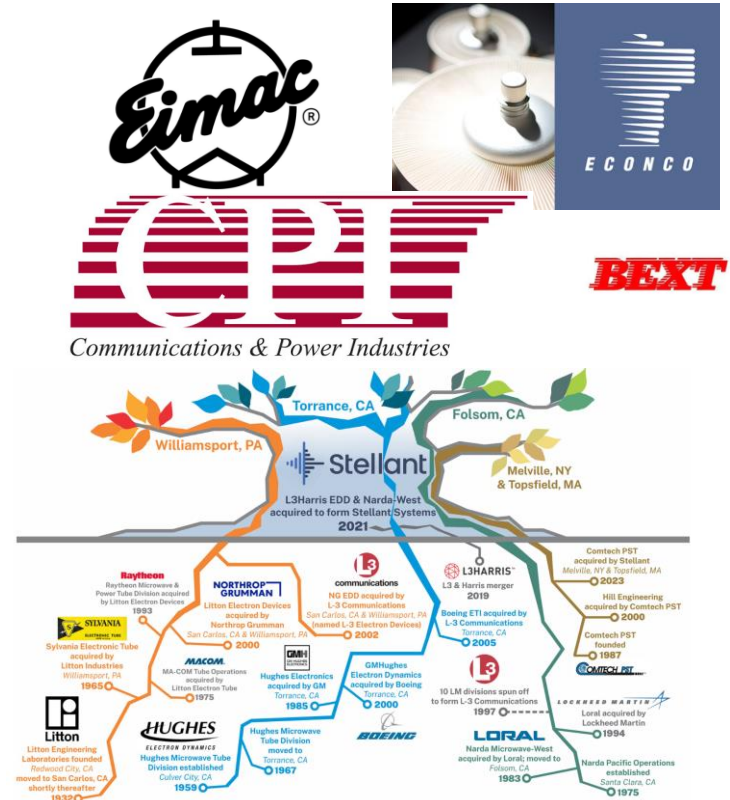

In June 2024, TransDigm Inc. acquired the Electron Device Business from Communications & Power Industries and established CPI Electron Device Business.

CLEVELAND, Dec. 31, 2025 /PRNewswire/ -- TransDigm Group Incorporated (NYSE: TDG) today announced it has entered into a definitive agreement to acquire Stellant Systems, Inc. ("Stellant" or "the Company"), a portfolio company of Arlington Capital Partners, for approximately \$960 million in cash, including certain tax benefits.

Demand of RF Sources for Accelerators

There is a misalignment between RF source manufacturers business needs and development of new capabilities in the DOE

Scientific demand for RF Sources is often discontinuous

- High demand during system commissioning
- Low demand during facility operation
- Many non-standard RF Source variants

Accelerator pulsed RF power needs are still difficult to reach with SSPA, however industry largely uses solid state devices in a wide array of applications

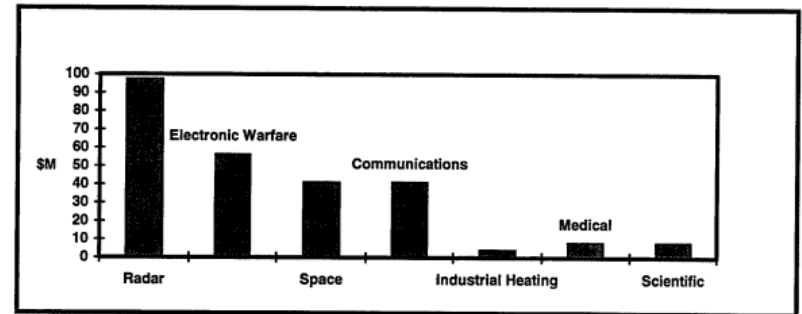
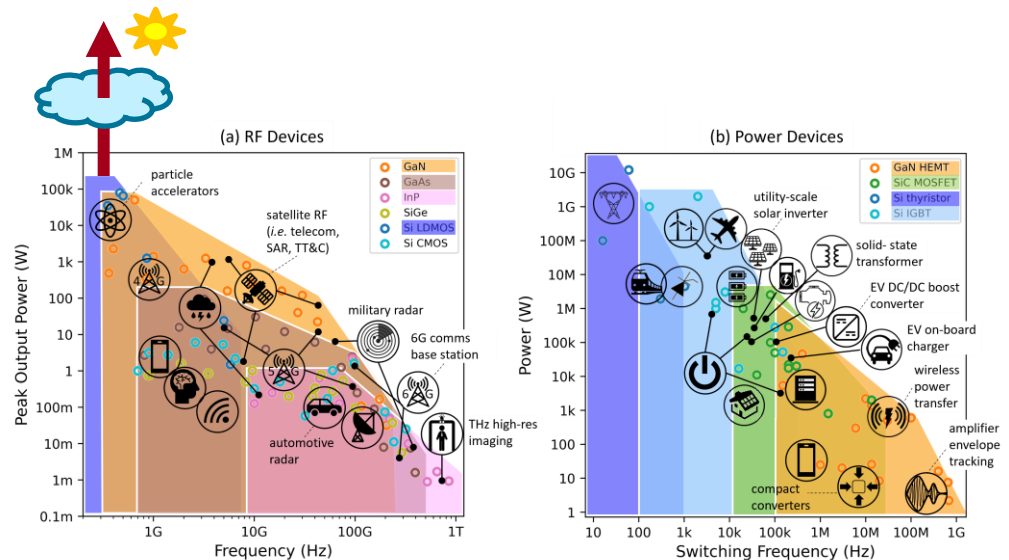

Figure 10: U.S. Microwave Tube Sales (FY95) by Application Area

Source: Technology Service Corporation⁵



What do New Manufacturing Technologies Enable?

Efficient utilization of information in fabrication processes

- Increased use of CNC/automated processes
- Additive manufacturing
 - Enables new design spaces
 - Tooling free fabrication
 - Common Material Feed Stocks
- New methods of working with materials
- Agile manufacturing practices → lower lead times
- Realignment with industry processes → higher availability manufacturing



New Designs



Aluminum Oxide



System Integration



Maximilien

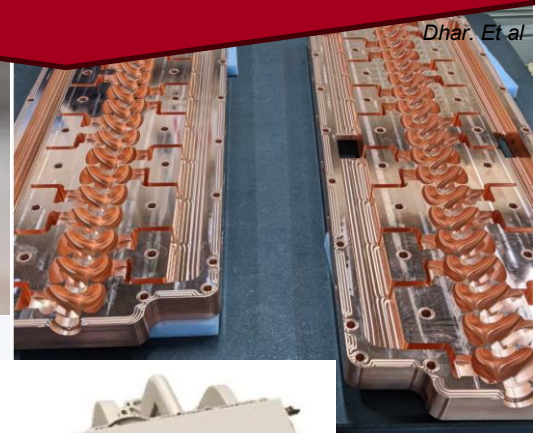

Dhar. Et al

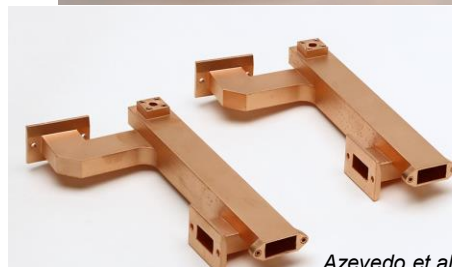

Azevedo et al



New Manufacturing Methods Enable Design Integration

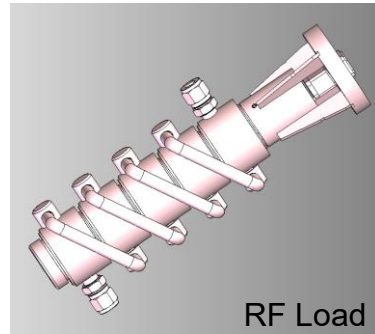
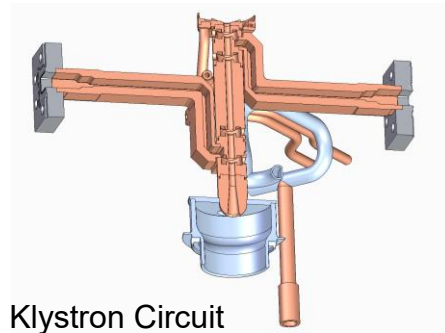

Complex Assembly
Simple Parts

Assembly tends to be manual:

- Brazing
- Welding
- Fasteners

Automated part fabrication makes complexity more practical:

- CNC Machining
- Additive Manufacturing

Part complexity allows for more optimization and integration

Manufacturing
Advances

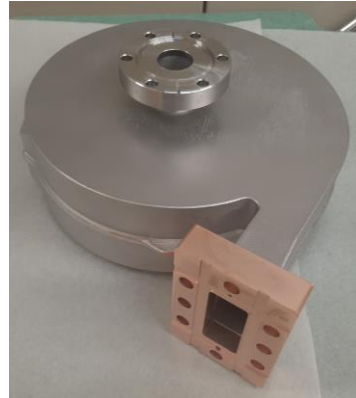
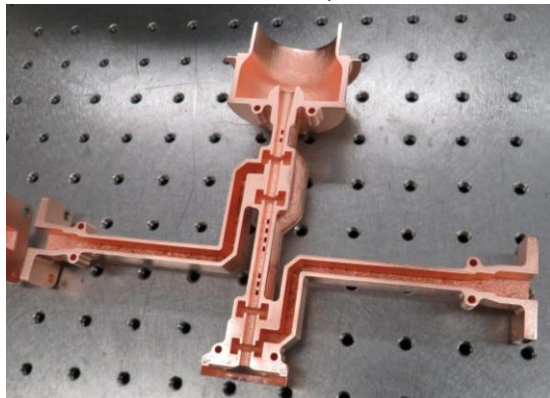

Complex Higher
Performance Parts
Simple Assembly

Additive Manufacturing

Why Additive Manufacturing (AM)?

- Reduces the cost of complexity
- Enables new designs
- Complements traditional manufacturing methods

Many additive manufacturing services commercially available:

- E-Beam:
 - Refractory and reactive metals
- Laser Sintering:
 - Net shape solid metal parts
- Stereolithography
 - Cheap, precise, plastic fast
- Electroforming:
 - Precise metal parts

Additive:

- Near Net Shape Deposition
- Prototype Parts

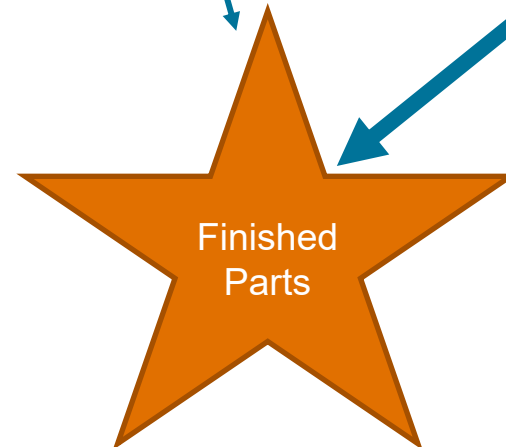

Traditional:

- Machining
- Polishing
- Tapping
- Welding
- Grinding

Explorations of Additive Manufacturing Methods

- Plated SLA plastic parts enable fast prototyping of RF structures
- Laser sintered processes enable vacuum compatible parts and new design paradigms

X-Band Test Cavities



Laser Sintered
Copper

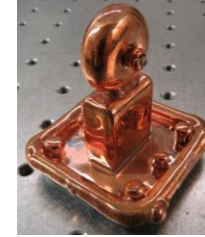

Electroformed
Copper

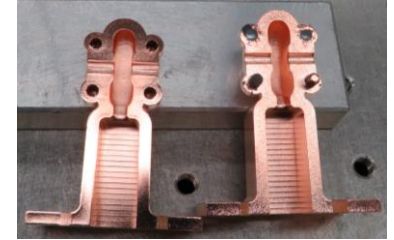

Copper on Plastic

HPRF C-Band Load

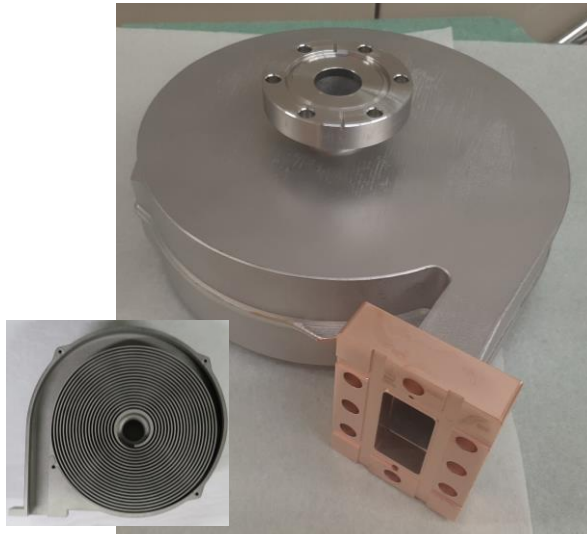

G. Mathesen, C. Wehner, J. Merrick

Gaussian Horn (Copper on Plastic)



M. Othman, C. Wehner, and J. Merrick

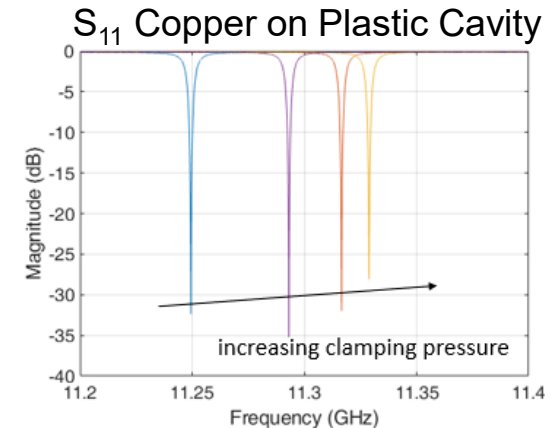

M. Othman, C. Wehner, and J. Merrick

SLAC's Focus: Process Validation for RF Applications

Accelerator systems have unique stringent requirements

- UHV Compatibility
- Surface finish
- Precision
- Very High Power
- Radiation compatibility

Integration with existing manufacturing processes is beneficial for adoption of new technologies

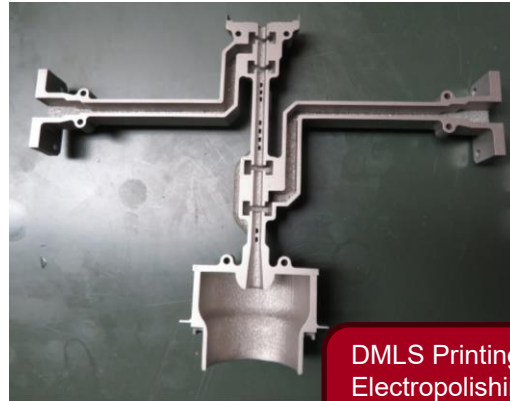

DMLS Printing
Electropolishing
Plating
Brazing

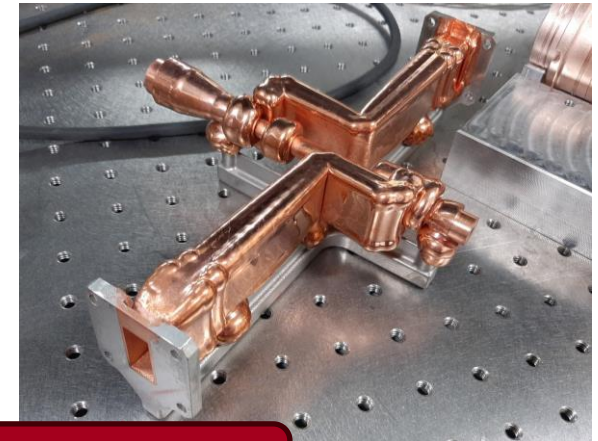
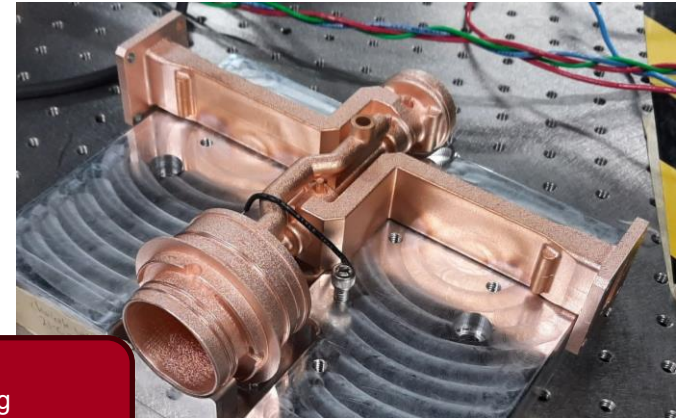

DMLS Printing
Multi-material Electroforming

Risk and Transition of Manufacturing Technologies

How can these new manufacturing technologies benefit RF powertrains?

- Decrease the cost of RF powertrains through system integration
- Expand the viable manufacturing supply base
- Enable new designs to increase system performance

Why don't we use new technologies and update legacy designs?

Risk/Cost

- New technologies must support a business case for industry adoption
- Variable demand has difficulty supporting R&D
- Reliability is a key metric for light source facilities

MRL Development Handoff

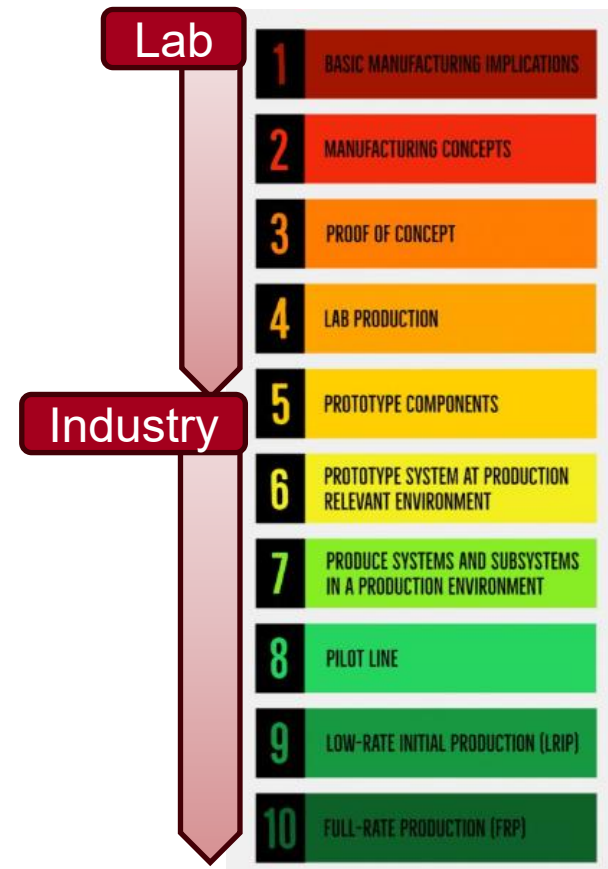

Summary

RF Powertrains are essential to enabling RF accelerator technologies

- To maintain current facilities there must be a supply of fit/function compatible RF Powertrains
- Demand levels and funding cadence have difficulty keeping specialized technologies in production by industry

Manufacturing advancements applied to accelerator RF powertrains can enable new capabilities and reduce costs for systems however effort is needed to increase the MRL/TRL for adoption in high reliability applications

Advances in system integration and optimization enabled by manufacturing technologies can increase power density of RF powertrains (SSPA and VED) enabling opportunities for legacy systems.



Year:	2018	2023	2028
RF Sources	High perveance, low voltage, high efficiency, multi-dimensional beams / Efficient modulators / Virtual prototyping tools / Prototypes / Energy recovery		
	Discrete Architecture	Distributed Architecture	Energy Recovery Concepts
Pulsed Sources Projected Cost Power Delivery Efficiency	Prototype Sources 20 \$/kW Peak Pulsed 65 MW/m 35%	Integrate with Accelerators 5 \$/kW Peak Pulsed 100 MW/m >50%	Technology Transfer 2 \$/kW Peak Pulsed 200 MW/m >70%
CW Sources Projected Cost Power Delivery Efficiency	CW sources 650 MHz / 1.3 GHz 5 \$/W Avg. CW 100 kW/m >50%	Cost-Effective CW Sources 2 \$/W Avg. CW 100 kW/m >70%	CW Sources at Facilities <1 \$/W Avg. CW 100 kW/m >80%

Radiofrequency Accelerator R&D Strategy Report 2017

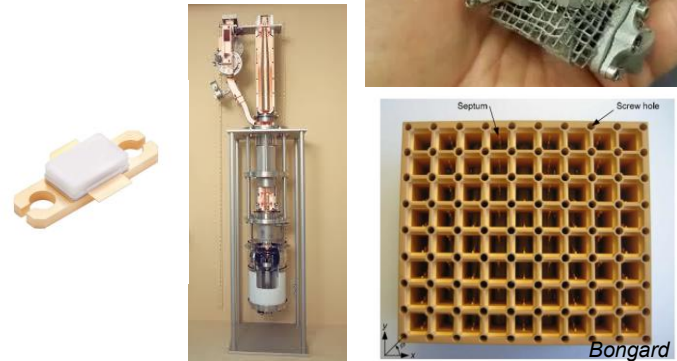

Questions?

SLAC