

# High Efficiency RF Sources

Mohamed Othman  
February 11, 2026

---

# Advanced Electron-Driven RF Sources

- Vacuum Electronics Devices (VEDs) remain the only viable technology for high-power (>50 kW) UHF/L-band generation with >50% electronic efficiency, but the architecture must evolve to meet efficiency needs

$$\text{Beam perveance } P = \frac{I}{v^{3/2}}$$

- Pulsed*:  $\gamma \sim 1.5-2$ , dominated by rf breakdown limits ( $P \uparrow \eta \downarrow$ ).
- CW*:  $\gamma < 1.1$ , dominated by space-charge depression and thermal dissipation limits ( $P \downarrow \eta \uparrow$ ).

2017 DOE Radiofrequency Accelerator R&D Strategy Report

## RF Source Roadmap

Year:	2018	2023	2028
RF Sources	High perveance, low voltage, high efficiency, multi-dimensional beams / Efficient modulators / Virtual prototyping tools / Prototypes / Energy recovery		
	Discrete Architecture	Distributed Architecture	Energy Recovery Concepts
Pulsed Sources Projected Cost Power Delivery Efficiency	Prototype Sources 20 \$/kW Peak Pulsed 65 MW/m 35%	Integrate with Accelerators 5 \$/kW Peak Pulsed 100 MW/m >50%	Technology Transfer 2 \$/kW Peak Pulsed 200 MW/m >70%
CW Sources Projected Cost Power Delivery Efficiency	CW sources 650 MHz / 1.3 GHz 5 \$/W Avg. CW 100 kW/m >50%	Cost-Effective CW Sources 2 \$/W Avg. CW 100 kW/m >70%	CW Sources at Facilities <1 \$/W Avg. CW 100 kW/m >80%

*RF sources become the leading cost driver for normal conducting accelerators and a significant cost driver for superconducting accelerators.*

*Only with innovative concepts for designing and building RF sources will dramatic reduction in cost and increased efficiency be achieved.” This same report suggests*

# SLAC High Power RF Research & Engineering Has Spanned 0.3 -100 GHz and up to 150 MW Peak Power

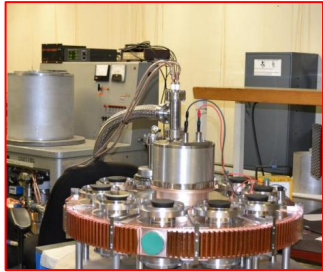

## SLAC/Stellant

**MB IOT**    **HE IOT**  
 700 MHz 1.2    1.3 GHz  
 MW    100 kW cW

GARD 2022  
 RF Acceleration Technology (RF)

*“Prioritize the development of high-efficiency RF sources, aiming to demonstrate a prototype tube with increased power efficiency and reduced costs within the next few years”.*

**SLAC** GARD Roadmap: RF sources

**Compact X-band**  
 11.4 GHz 300 kW

**XP**  
 X-Band  
 11.4 GHz, 50 MW  
 PPM focused

**5045 Klystron**  
 S-Band  
 • 2.856 GHz, 65 MW

**XL4 & XL5**  
 X-Band  
 11.4 GHz, 50 MW  
 @SLAC  
 CERN  
 Sinc. Trieste  
 PSI  
 BNL  
 LLNL

**B Factory Klystron**  
 476 MHz  
 1.2 MW CW

**W-Band Sheet Beam Klystron**  
 95 GHz

Span wide range  
 • 0.3 - 100 GHz  
 • 100 kW CW – 150 MW Peak

# 5045 Klystron: Efficiency Improvements

- 5045 klystron is the workhorse of LCLS
- Still significant opportunities for improvement in performance.
- Retrofitting the 5045 for higher efficiencies

Ongoing efforts toward modernizing 5045 production pipelines.



## Experimental work (2015-present)

1. Additional bunching cavities
2. Adding multi-stage depressed collector

**Table 1.** Calculated improvements in system efficiency for two SLAC klystrons.

	<b>XL4</b>	<b>5045</b>
<b>Peak Power (nom.)</b>	50MW	58MW
<b>Klystron efficiency</b>	41%	45%
<b>System Efficiency (no recovery)</b>	29%	37%
<b>Depressed Collector Efficiency (assumed)</b>	55%	55%
<b>System Efficiency (with recovery)</b>	50%	57%
<b>Collector Power (no recovery)</b>	22 kW	41 kW
<b>Collector Power (with recovery)</b>	8.8 kW	16 kW

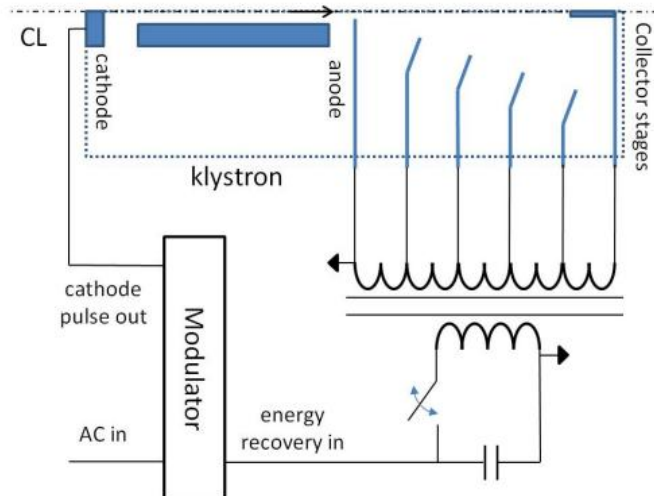

GARD Roadmap: RF sources

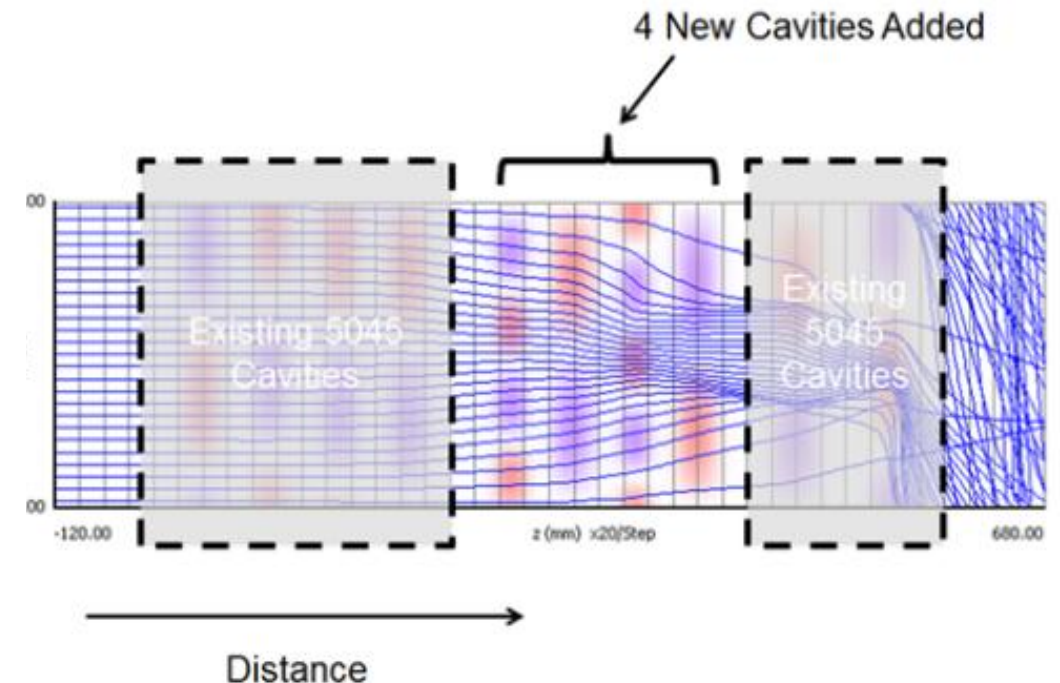

# Engineering of High Power Klystron Output Structures for Reduced Breakdowns and Increased Efficiency

- The 75XP4 is a high power SLAC klystron fitted with a PPM to produce 75 MW at 11.424 GHz.
- Output structure is a tapered impedance constant gradient traveling wave structure

Optimized the output structure to reduce RF breakdown risk and increase extracted power

- Adjusted output cell shape and iris to reduce peak E and H fields. Pulse heating reduced substantially
- Increased efficiency by >6%

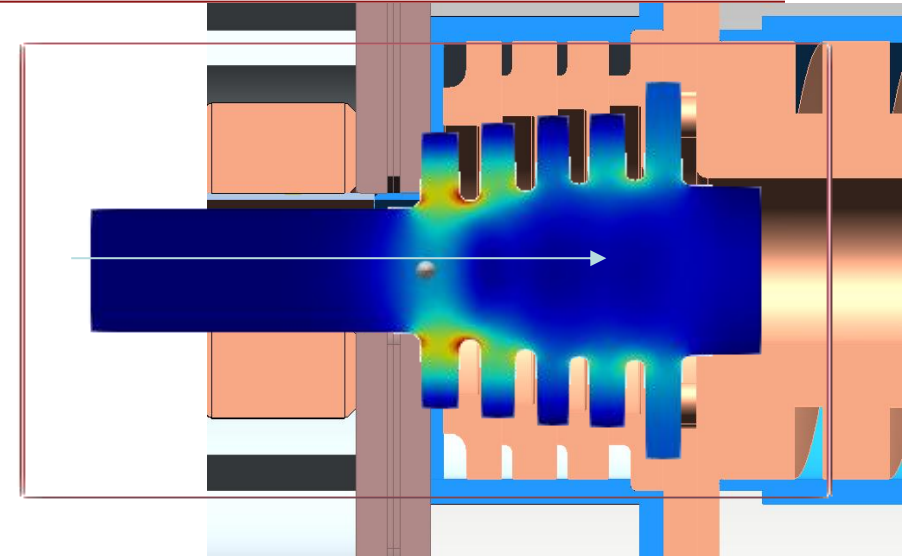
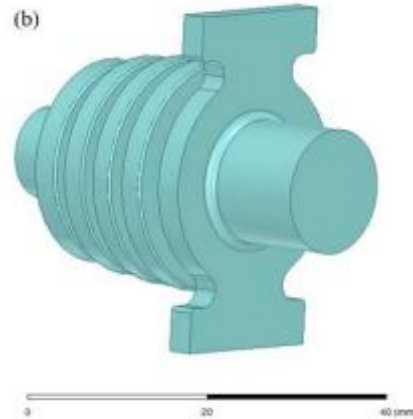
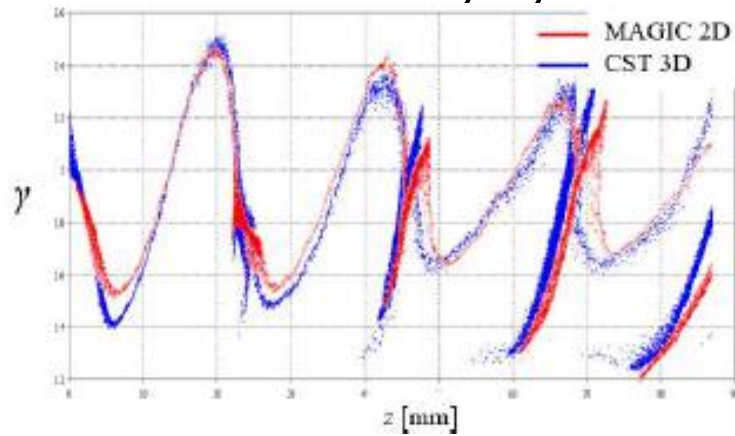

Output Pulse Heating Reduced  
152 K → 60 K at 75 MW

	Baseline	Redesigned
Peak E field	108 MV/m	<b>100 MV/m</b>
Peak H field	500 KA/m	<b>303 KA/m</b>
Poynting vector	2.24 W/um <sup>2</sup>	<b>2.24 W/um<sup>2</sup></b>
Pulsed heating 1.6 us pulse	<b>152 C</b>	<b>50 C</b>
Efficiency	59%	<b>65%</b>

# MB IOT – Route to Higher Beam-to-RF Efficiency

- MBIOT is a collaborative effort between SLAC and L3 (Stellant)
  - Power of 1.2 MW was demonstrated at 40 and 42 kV •
  - Efficiency above 65% from the 1.2 MW power level down to 650 kW
  - Gain over 20 dB was demonstrated at most power levels, with maximum gain of 21.9 dB

Prototype was successfully delivered to ESS

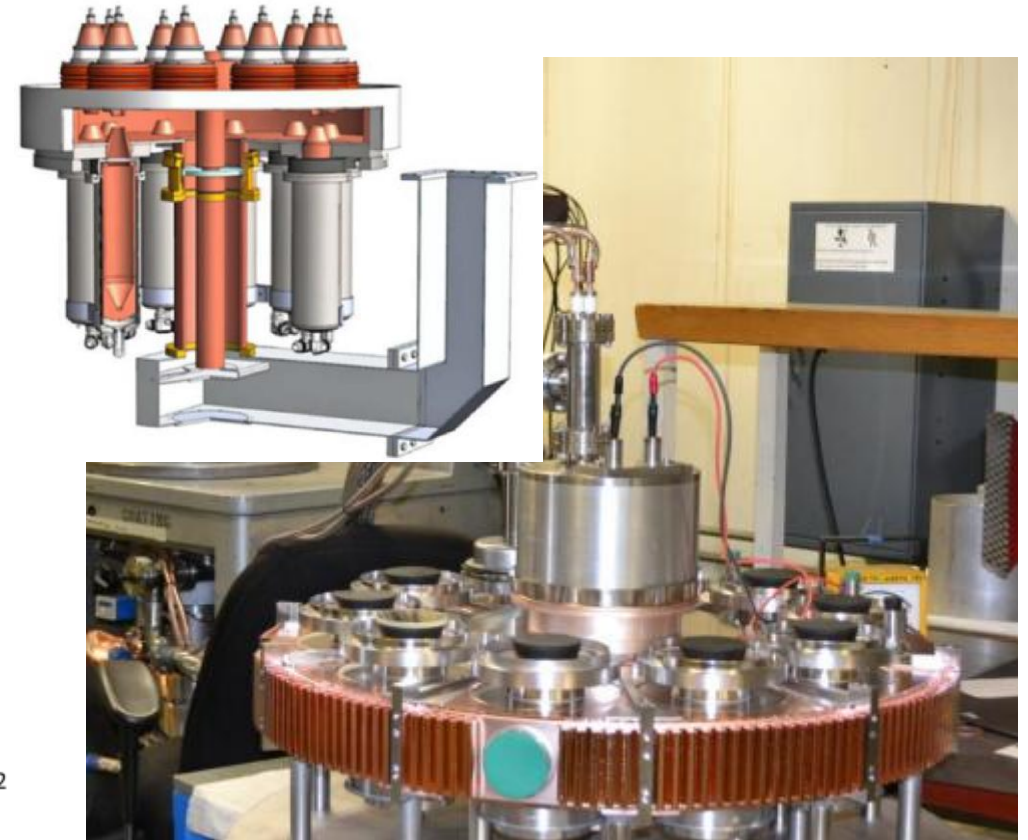
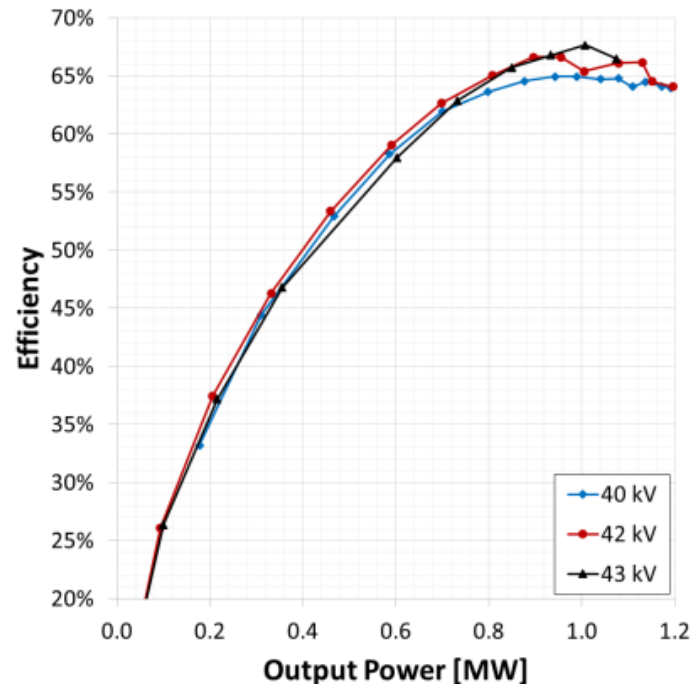
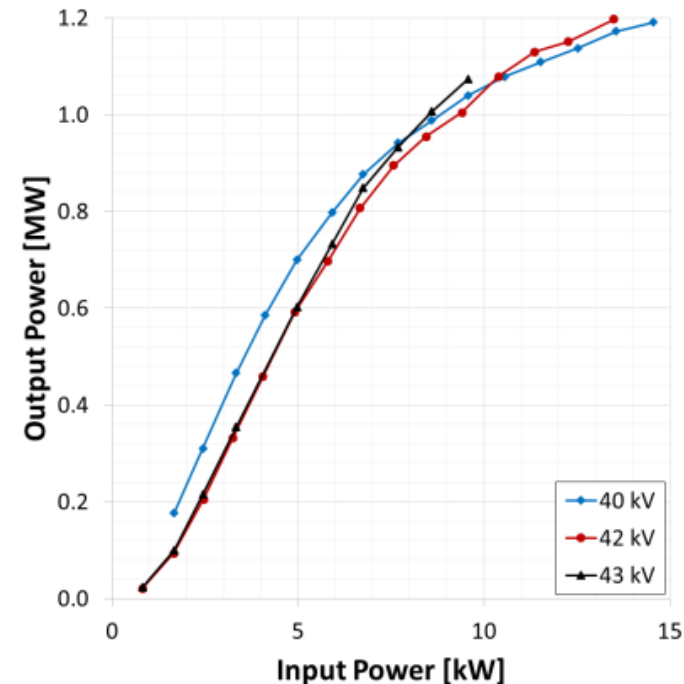

# High Efficiency IOT (HEIOT) - Concept

- The High-Efficiency IOT (HEIOT) program aims to deliver a scalable 1.3 GHz CW amplifier with 100 kW output and >80% wall-plug efficiency.
- Efficiency gains come from a 3D optimization of velocity distribution of the gated electron gun.

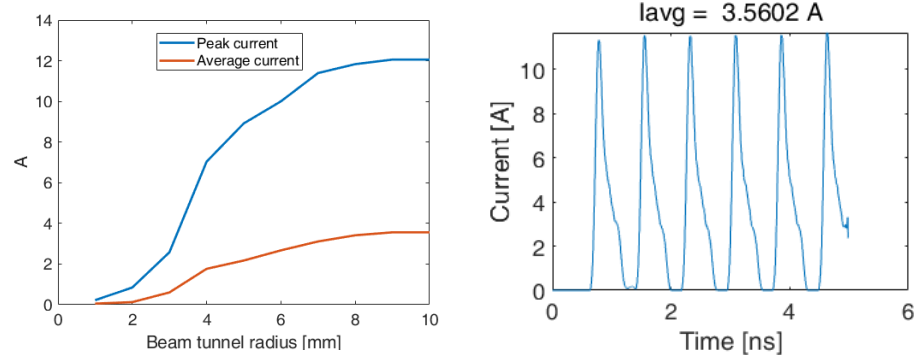

Parameter	Value
Cathode Voltage	40 kV
Frequency	1.3 GHz
Input RF power	550 W
Grid Bias	-220 V
Average Beam Current	3.2 A
Peak Focusing B-Field	470 G
Output Power	100 kW
Cavity configuration	Idler, 2 <sup>nd</sup> harmonic, output

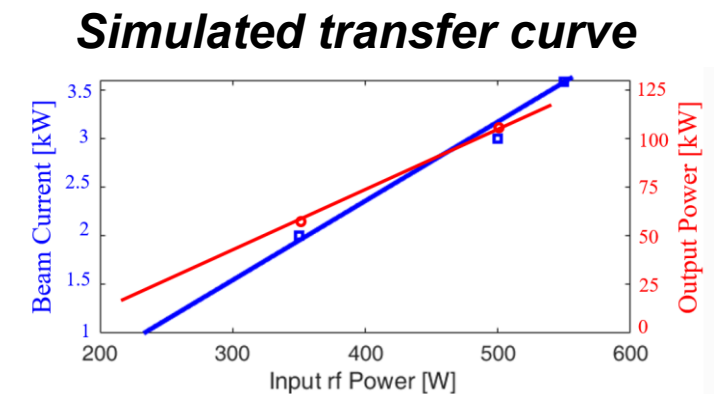
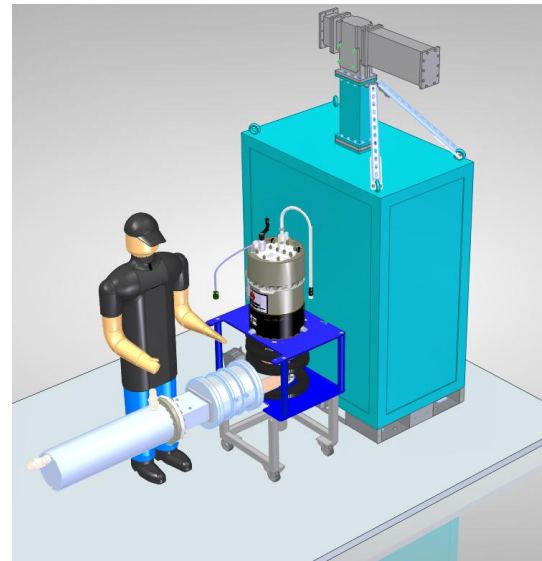
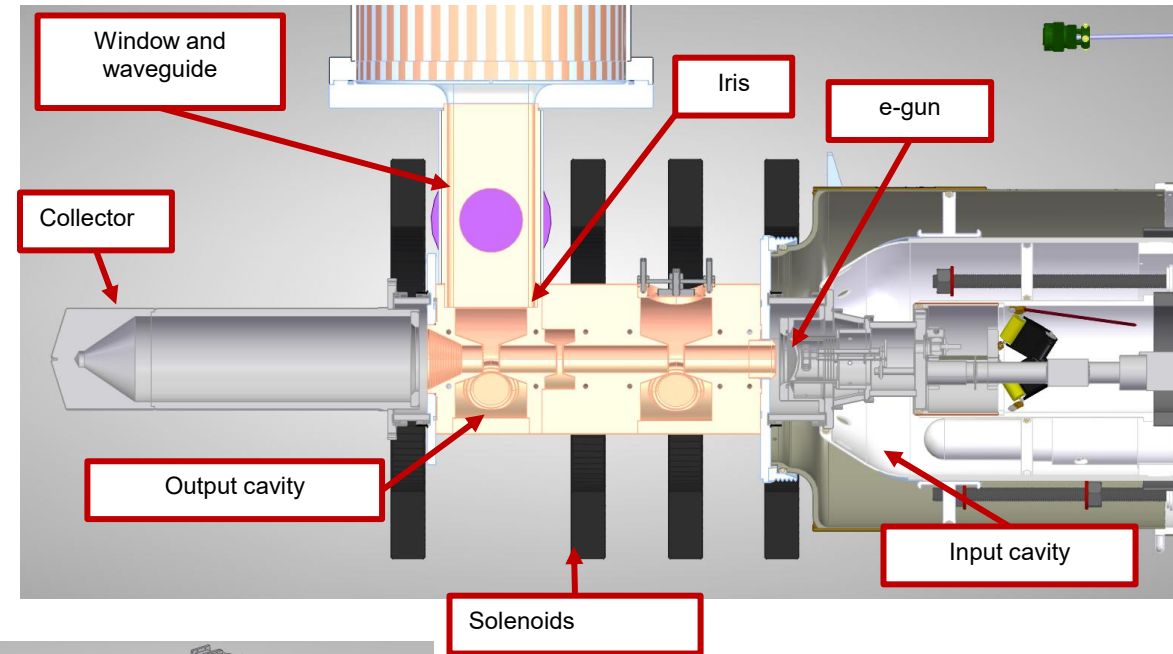

# High Efficiency IOT (HEIOT) - Design

- ACE3P provides accurate 3D models for advanced beam dynamics in space-charge limited RF guns.

**Cho Ng**

- The single-beam HEIOT RF circuit design achieves >80% efficiency at 100 kW and 1.3 GHz, incorporating complete 3D geometry effects.

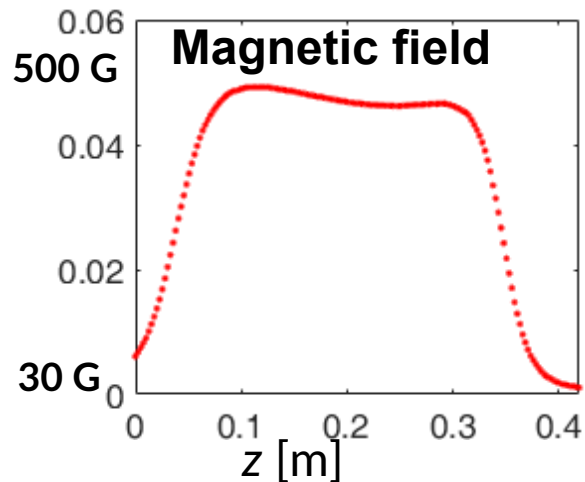
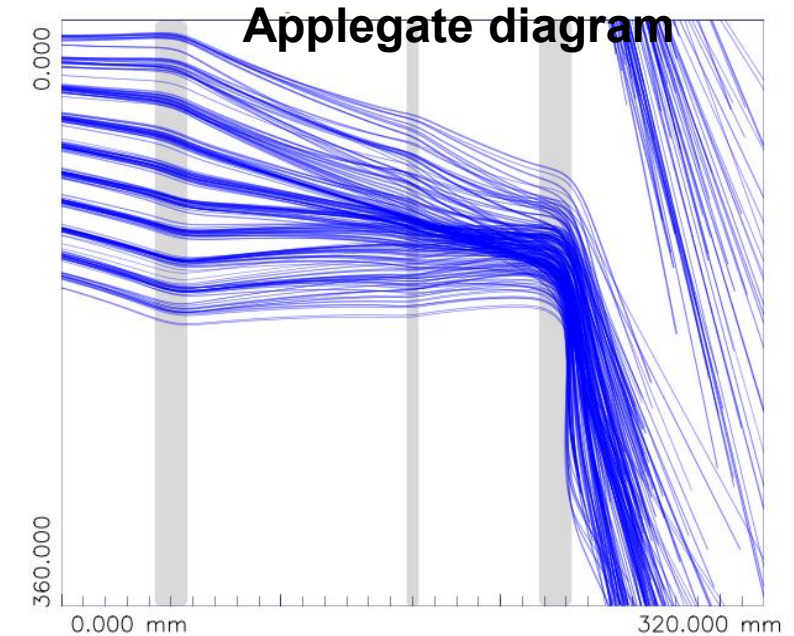
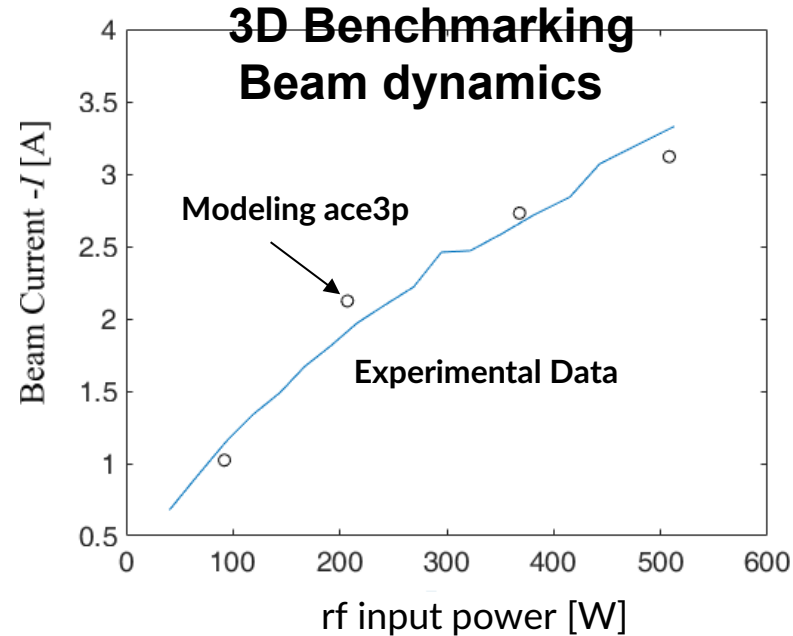

### Simulated thermal

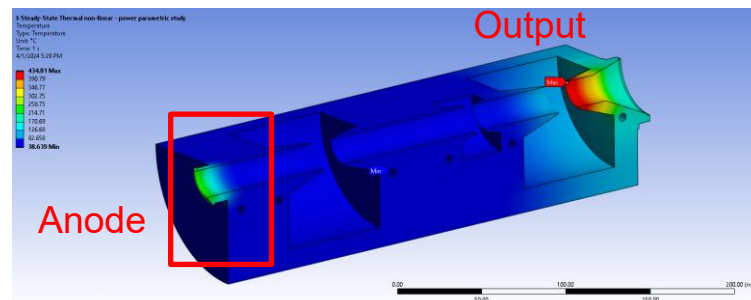

### Thermal model

Max. temperature vs input power  
HTC = 10000 W/m<sup>2</sup>/K

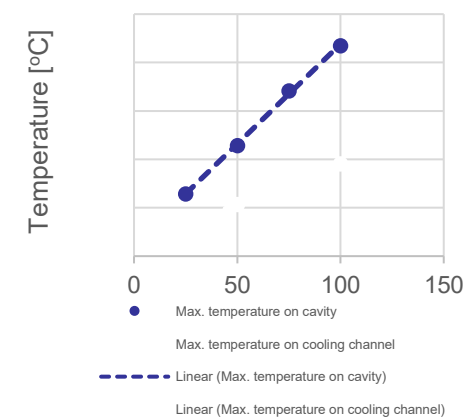

Max temperature vs film coefficient  
Power = 100 kW

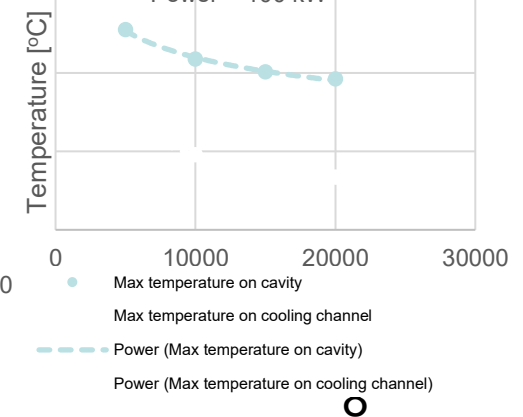

# High Efficiency IOT (HEIOT) - Production

- RF cavities have been fully fabricated, brazed, and assembled is in progress into the L-band test stand.
- Initial low-power and high-power input cavity conditioning and RF measurements are in progress.

This infrastructure provides a flexible environment to prototype, characterize, and iterate on next-generation high-efficiency RF sources with reduced turnaround time.

Cavity 1 - Gain fundamental Caity

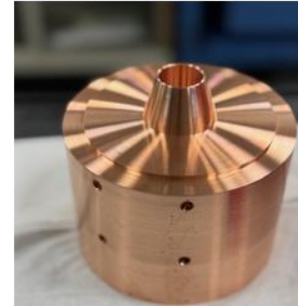

Cavity 3- output cavity assembly



Tuner



# Future Circular Collider (FCCee) RF needs

• FCC-ee has two unique RF needs.

- 400 MHz cavities minimize beam impedance and manage HOMs

- 800 MHz cavities double the accelerating gradient (20 MV/m vs. 10 MV/m)

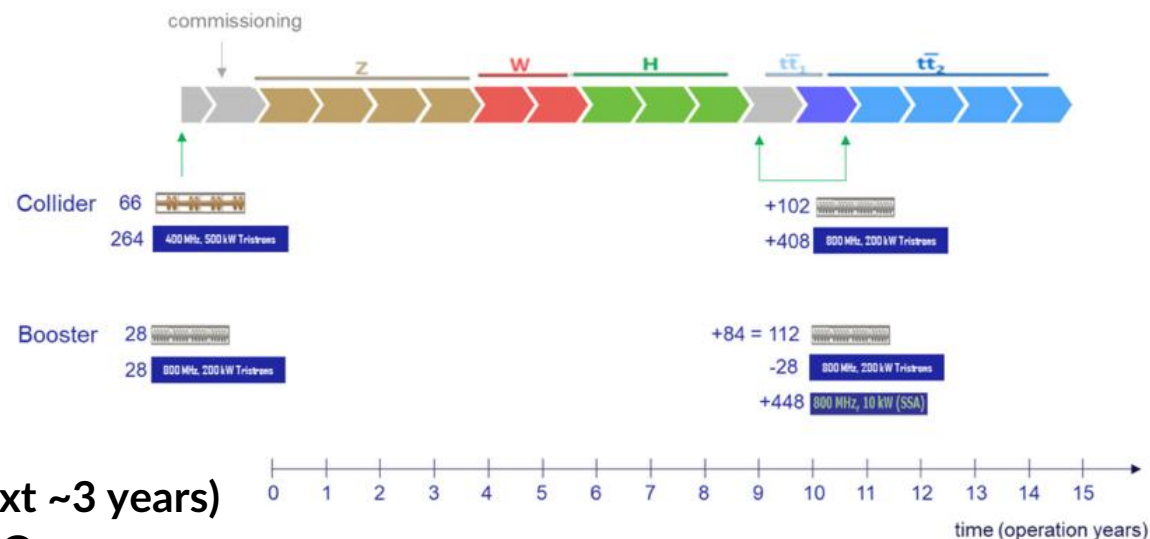

400 MHz baseline prototype (design/manufacture/test over the next ~3 years)

- TH2167HE 350 kW 67% efficiency (delivered) for HL-LHC
- TS MBK 1.3 MW >85% (in production)

			Phase 1			Phase 2			Total Installed RF Power (MW)
		Frequency (MHz)	Number	Power (MW)	Total RF Power (MW)	Number	Power (MW)	Total RF Power (MW)	
Collider	Tristron	400	264	0.5	132	-	-	-	218
	Tristron	800	-	-	-	408	0.2	82	
Booster	Tristron	800	28	0.2	6	-28	0.2	-6	
	SSA	800	-	-	-	448	0.01	4	
			Phase 1 RF Power (MW)			Phase 2 RF Power (MW)			
			138			80			

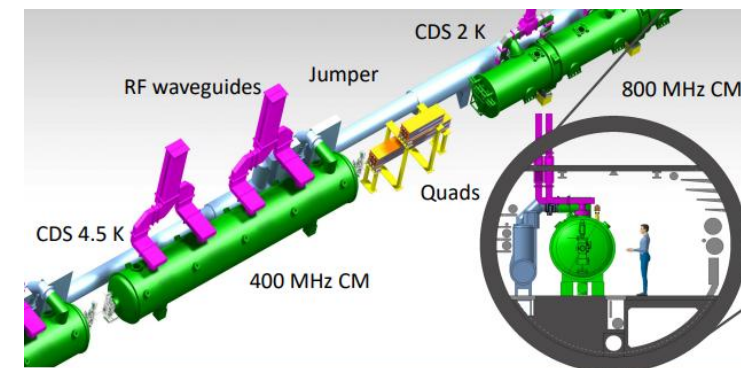

# Outlook for RF Sources – SLAC and Industrial Partnerships

- Scaling the production of high-power klystrons to meet next-generation collider requirements requires a strong, coordinated partnership.
- A parallel development hub with full Design → Fabrication → Test capability (vacuum electron device R&D + in-house simulation tools and build + high-power test).
- Leverage current industrial partnership with industry and test stand capabilities
- Mitigates single-point-of-failure risks (vendor bottlenecks, specialized tooling, long lead parts) and accelerates the FCC-ee RF roadmap via two independent build/test streams with industrial partnership.



## TWIN BUILD (Redundancy)

400 MHz, 500 kW CERN  
Design Copy Second  
Supply Chain

## COLLIDER EXPANSION

800 MHz, 200 kW Joint  
Engineering Scaled from  
400 MHz

## FAST-TRACK

800 MHz, 50 kW Rapid  
Prototype CERN Physics  
+SLAC + industry  
Hardware Low Cost,  
Short Lead Time

# 800 MHz Sources Development

- There is currently no commercially available high-efficiency (>80%) RF source at 800 MHz in the 50–200 kW power range.
- Standard commercial IOTs at this frequency (e.g., TV broadcast tubes) “can” operate at **>70% efficiency**.

Very high reliability with average >100 kh operation

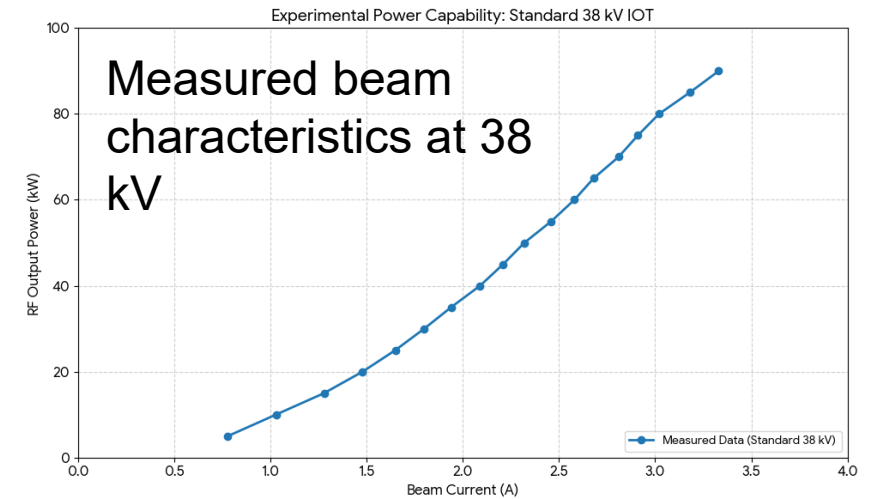

- Broadcast IOTs UHV operates from 470 – 800 MHz up to 90kW
- HE IOT techniques can be readily applied to achieve >85% at 50 kW

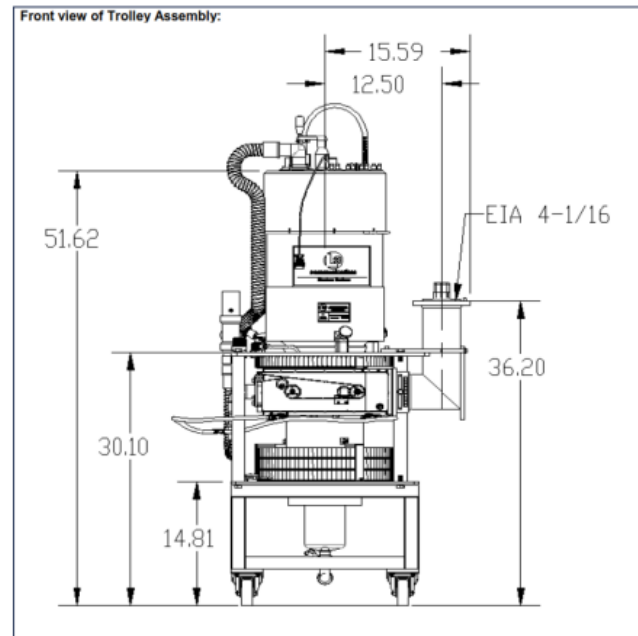

Frequency	800.xx MHz
Output Power	50 kW CW
Beam Voltage	30-40 kV
Beam Current	1.5-2 A
Core Technology	IOT Geometry, with harmonics and post acceleration
Target Efficiency	> 85%

# Preliminary Design of HE IOT at 800 MHz

- High-Efficiency IOT "1-2-1" scheme with the first cavity placed ~110 mm from the gun.
- ACE3P simulations confirm a stable 40 kV beam with 0.25  $\mu\text{P}$ .
- Employing a standard solenoid field with a peak of ~453 Gauss.

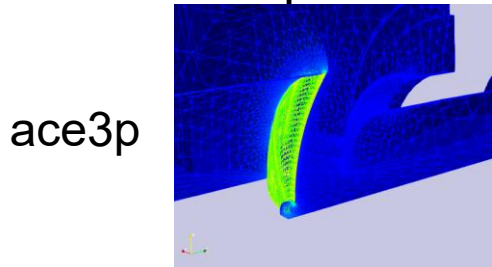

TESLA

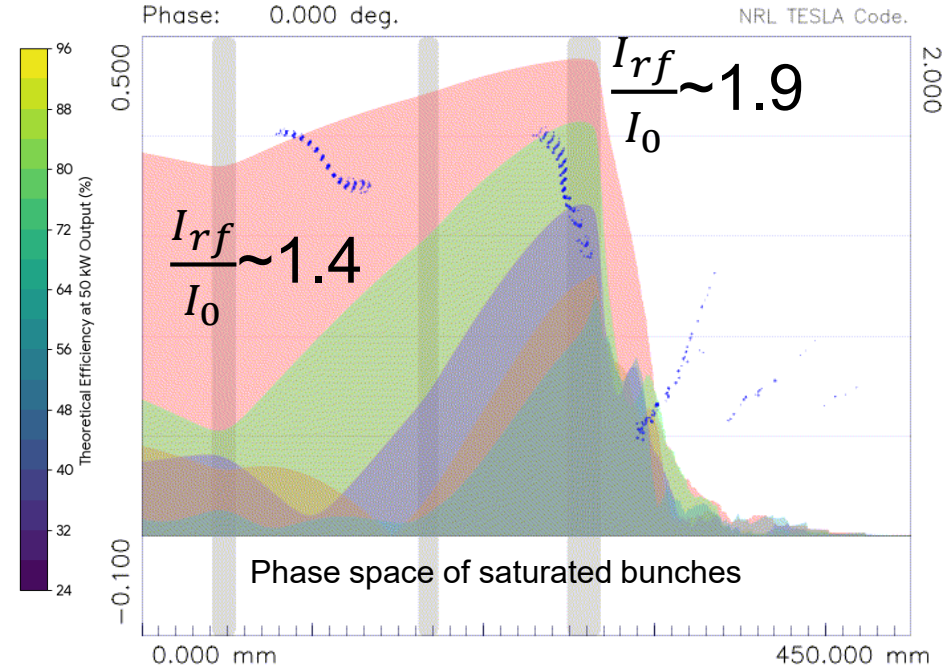
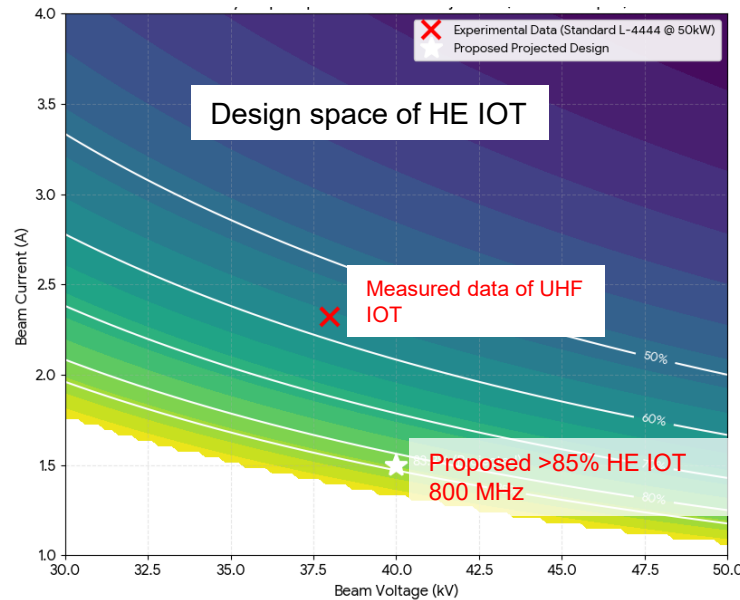
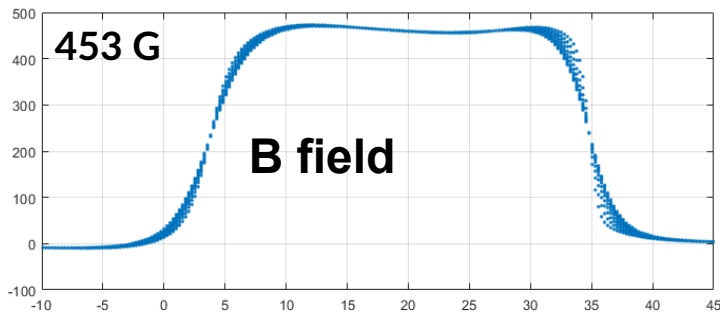

	Cav 1	Cav 2	Cav 3
$F_0$	808.7 MHz	1645 MHz	800 MHz
R/Q	142	139	140
$V_{rf}$	13 kV	5 kV	42 kV

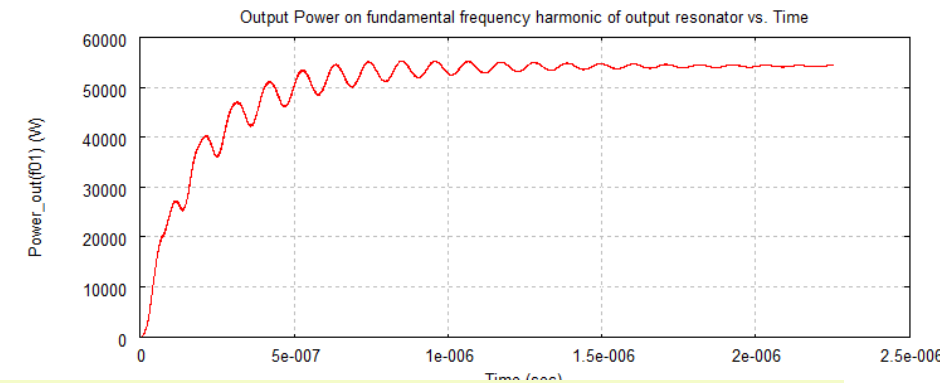

Scaling the proven HE-IOT platform to 800 MHz provides a robust and mechanically feasible path to meeting FCC-ee efficiency targets (>85%).

# Pathway to >85% Efficiency

- Initial design efficiency is 83% @ 50 kW
- Can we do better?
  - Pathway to >90%.

## Multi-staging (\*CERN)

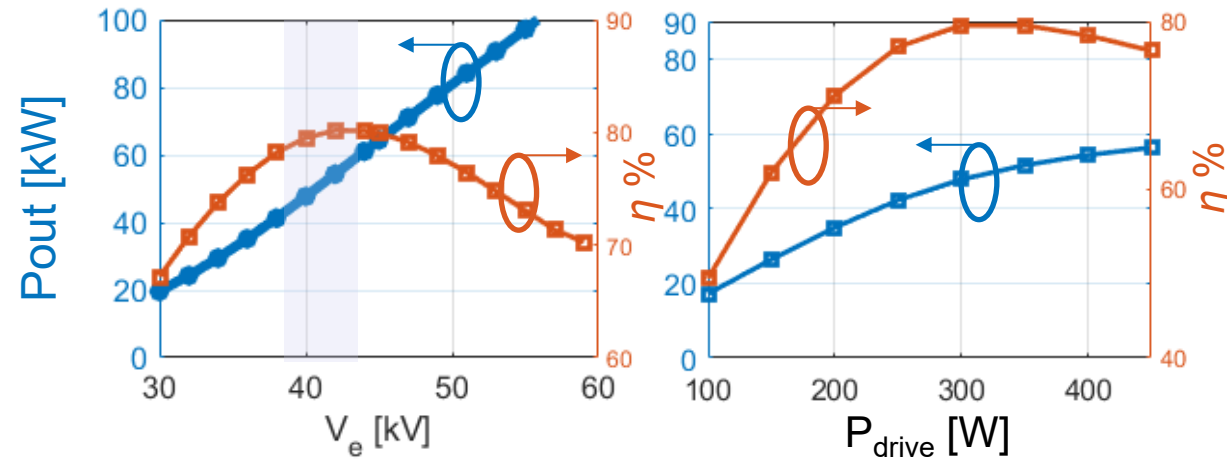
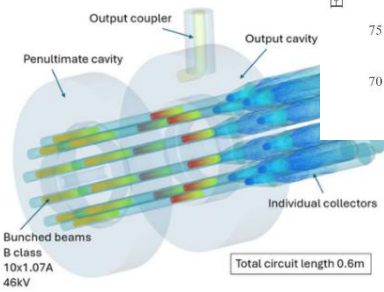
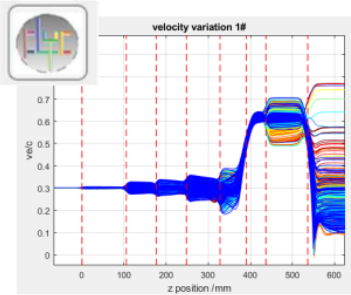

Syratchev I.

## Harmonic engineering (\*CCR)

Input cavity harmonics

$$V(t) = V1\sin(\omega t) + V2\sin(\omega 2t) + \dots$$

Cai, Jinchi, et al. "Beam optics study on a two-stage multibeam klystron for the future circular collider." *IEEE Transactions on Electron Devices* 69.8 (2022): 4563-4571.

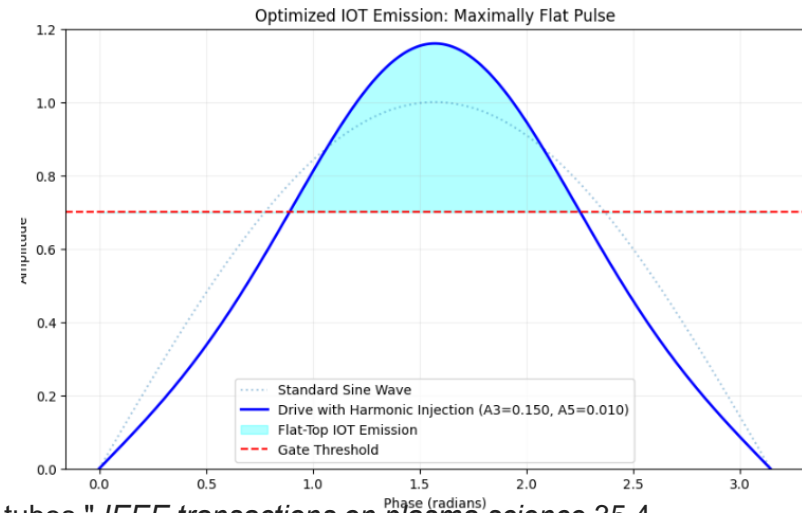

Freund, H. P., et al. "Time-domain simulation of inductive output tubes." *IEEE transactions on plasma science* 35.4 (2007): 1081-1088.

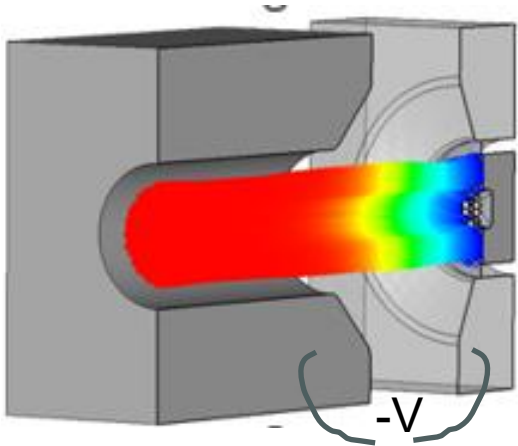

# HE IOT High Peak Power Concepts

*Scaling klystrons to lower frequencies increases length significantly.*

- Integration of pulse compressors to achieve ~MW pulsed from 150 kW CW sources

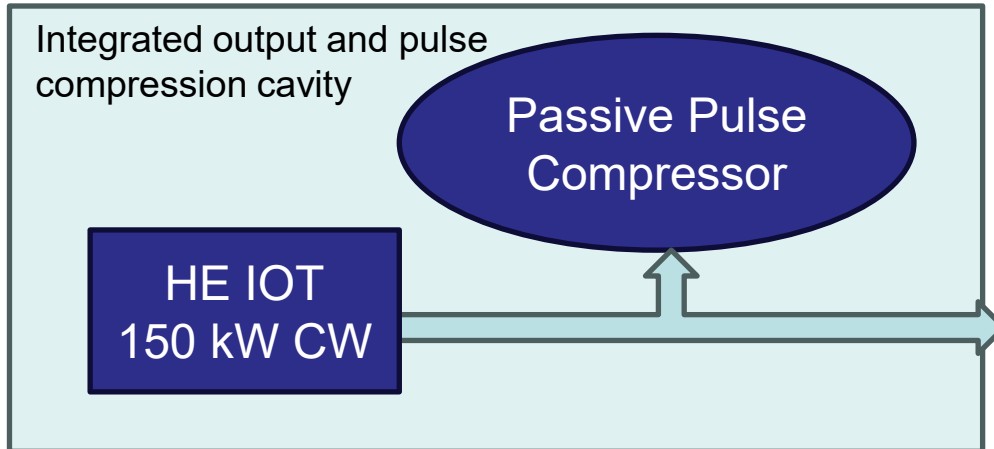

- high-Q, low-loss passive pulse compressors capable of handling multi-MW flat top pulses
- Pulse compressor cavity within the output for a fully integrated pulsed system

1 MW, 50 ns pulses, 10 Hz



- Multi-stage IOT to boot power to 1 MW

- *Lancaster/CERN TS MBK*
- *Jlab Magnetrons*

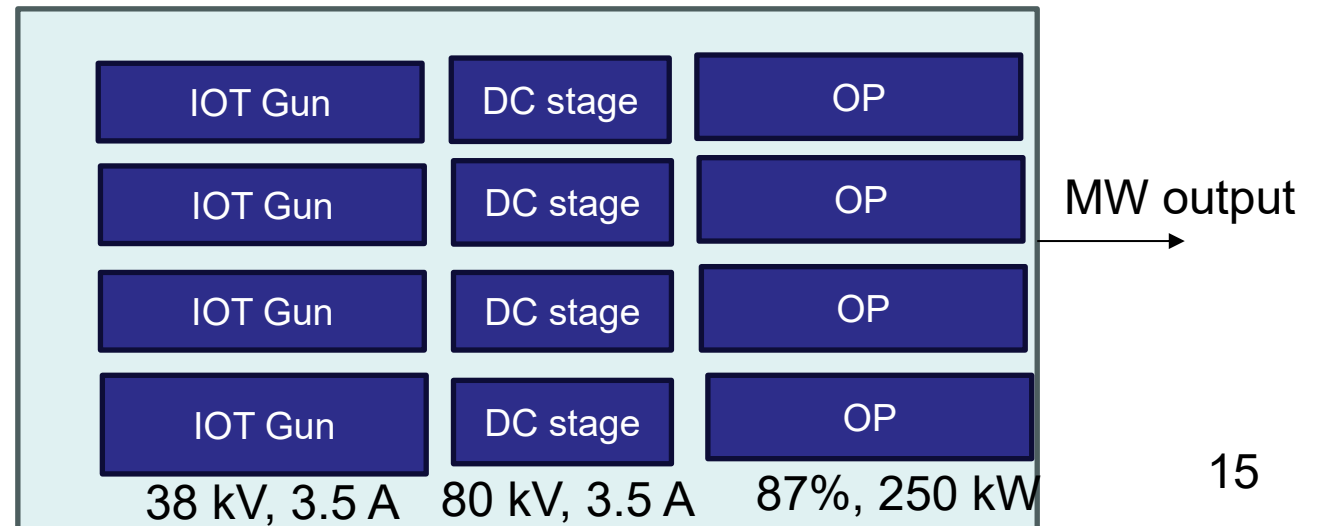

# Summary

---

- Landscape of high efficiency sources demands action toward leveraging strategic partnerships and collaborative programs
- Broad community engagement is required to support the scalable production of high-power klystrons for next-generation collider projects
- HE IOT: compact and scalable solution for wide frequencies range (400 MHz – 1.3 GHz) with the same topology
- Future potential of HE IOTs:
  - Collider application (FCCee or Muon collider)
  - Compact solution to UHF toward MW for industrial and medical applications