

CENNS-1ton
(a.k.a. COH-Ar-750)
for Precision Measurement
of Coherent Elastic Neutrino-Nucleus Scattering

Jonghee Yoo
Seoul National University

2026.02.10
SLAC FPD Seminar

CDMS (Early 2000)

CDMS Experiment

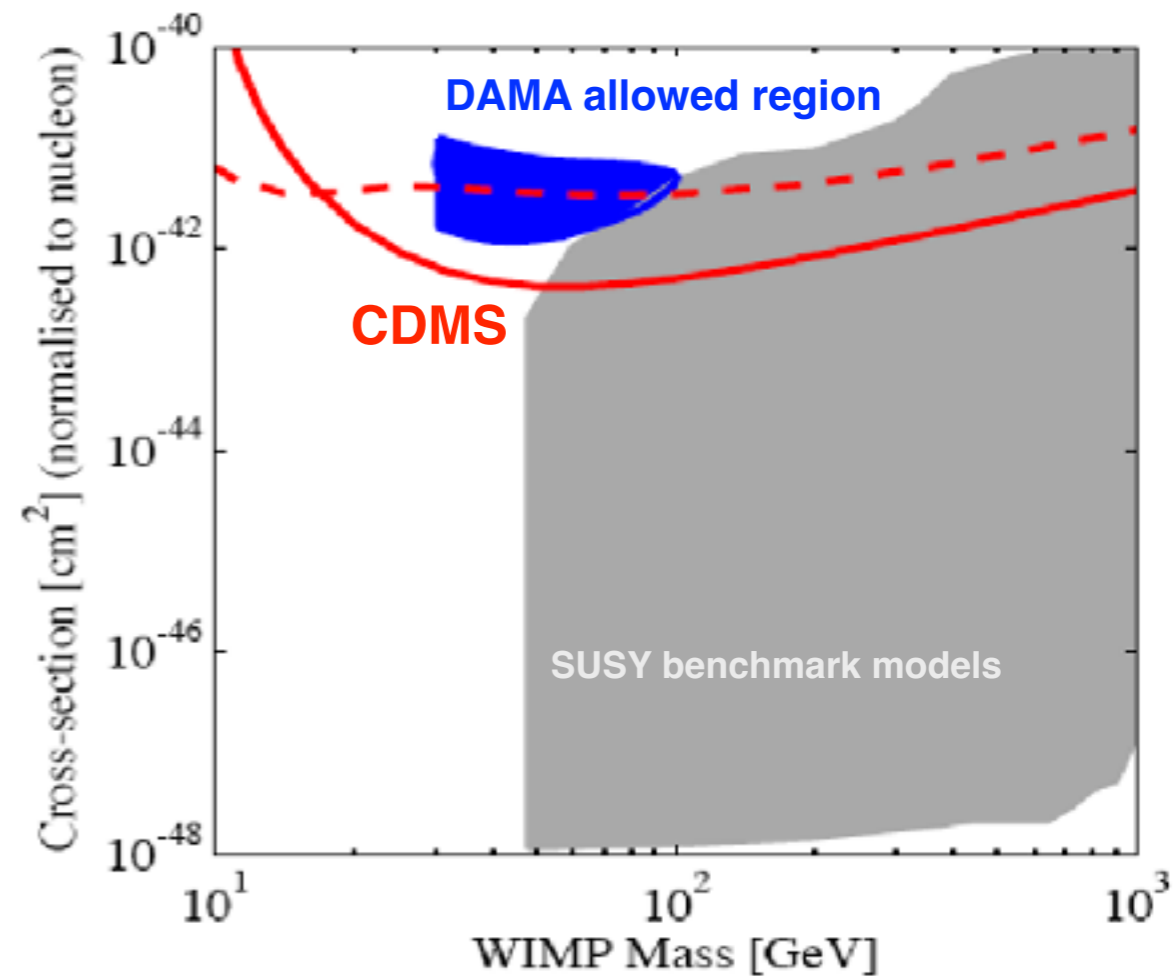
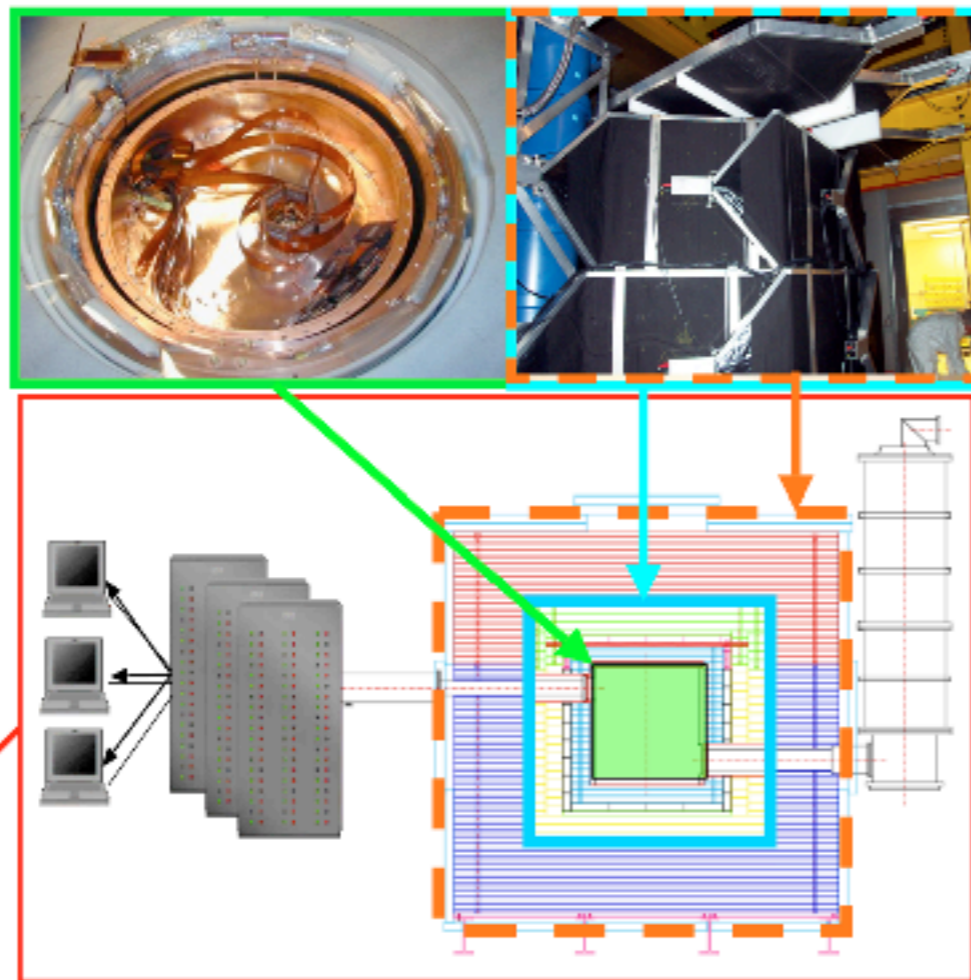
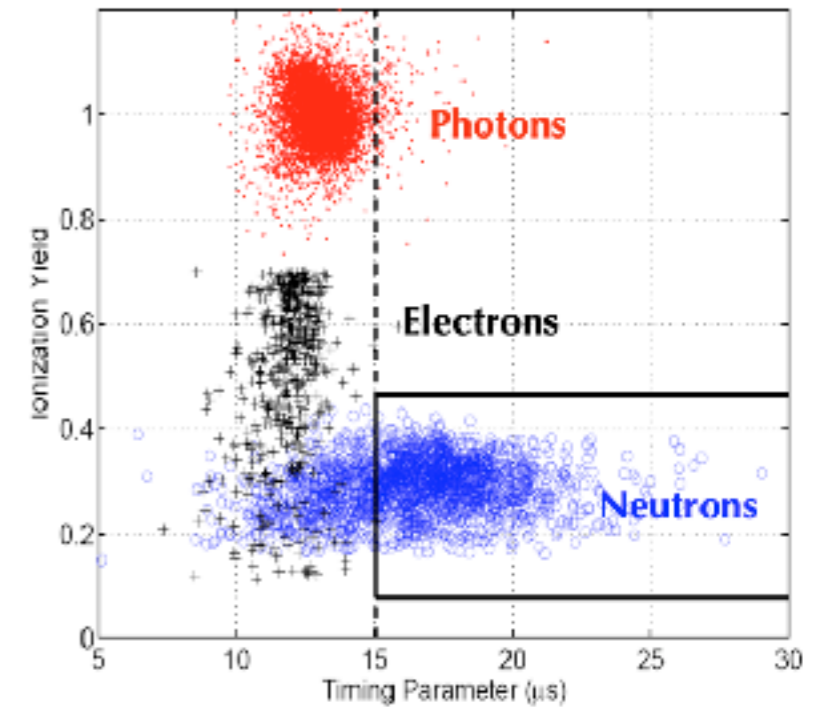
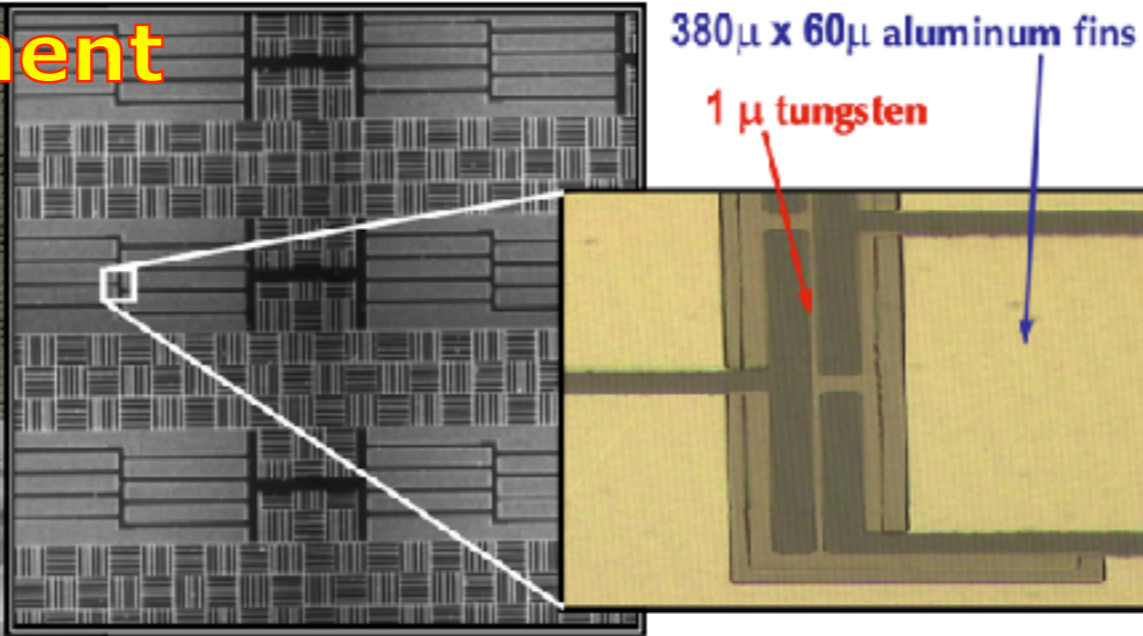
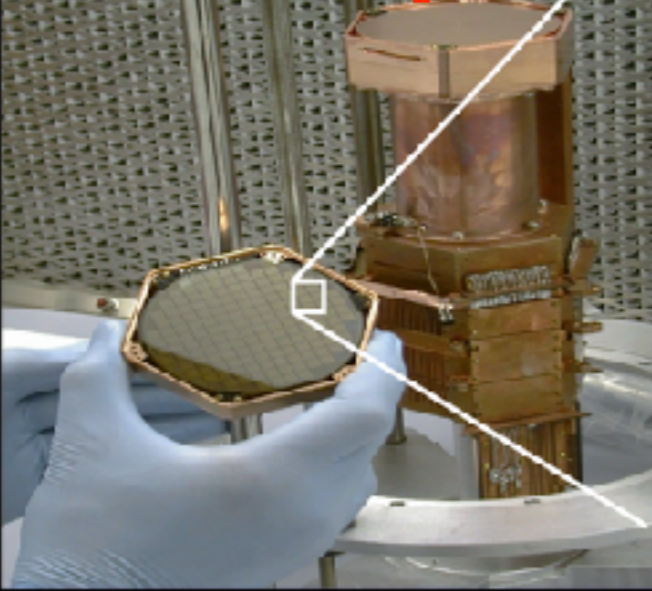

Solar Axions

Axion conversion by Coulomb field

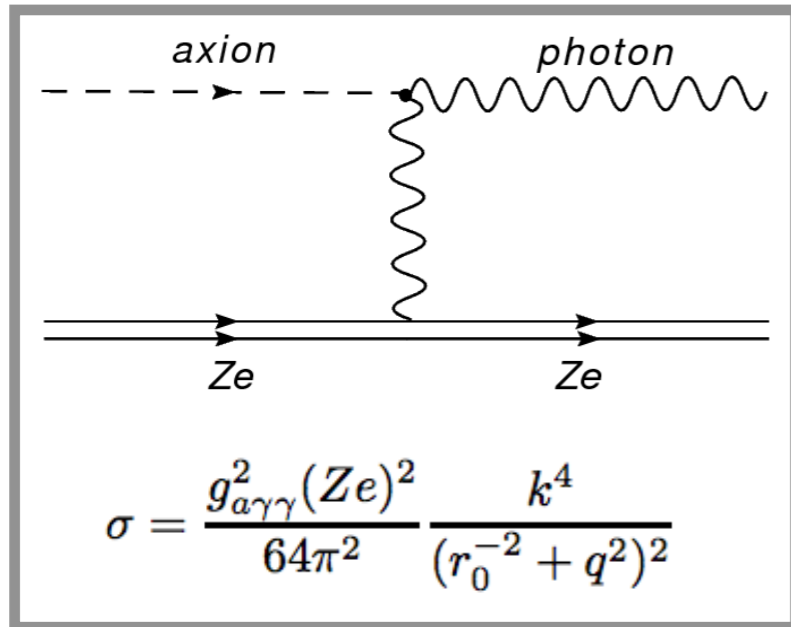

$$g_{a\gamma\gamma} = 10^{-8} \text{ GeV}^{-1}, k \approx \text{keV}, q \approx \text{keV}, Z \approx 100$$

$$\sigma \approx 10^{-43} \text{ cm}^2 !!$$

Bragg condition

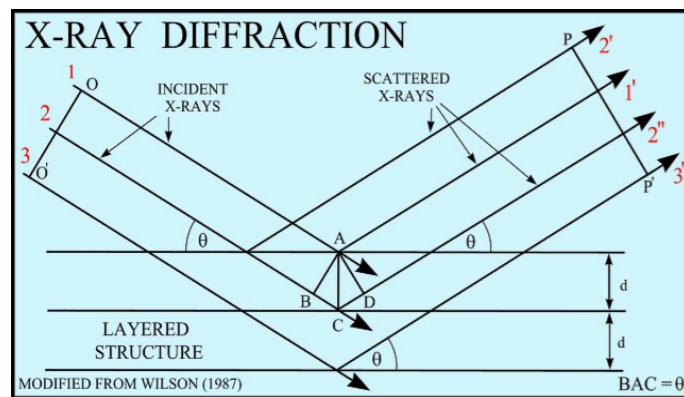

BRAGG LAW

$$2d(\sin\theta) = \lambda_0$$

where:
 d = lattice interplanar spacing of the crystal
 θ = x-ray incidence angle (Bragg angle)
 λ = wavelength of the characteristic x-rays

$$E_a = \hbar c \frac{|\vec{G}|^2}{2\hat{u} \cdot \vec{G}}$$



Solid Xenon Properties

Atomic number : Z	54	
Boiling point (1 [atm])	165	[K]
Melting point (1 [atm])	161	[K]
Triple point properties		
Density		
Gas	8.18×10^{-3}	[g/cm ³]
Liquid	2.96	
Solid	3.40	
Temperature	161.391	[K]
Pressure	612.2	[Torr]

$\Delta T = 4K$

Compact

	Gas	Liquid	Solid
W-value [eV]	21.5	15.6[1]	12.4[2] 19.5 [3]
Fano factor	< 0.17	0.0041 [1]	?
Electron drift velocity [cm/sec]	$\sim 10^5$ at 1[kV/cm]	3.0×10^5 [4] > 5[kV/cm]	5.0×10^5 [4] > 5[kV/cm]
Ion or Hole drift velocity [cm/sec]	Positive ion 0.76 at 1[kV/cm]	Positive ion 0.3 at 1[kV/cm]	Hole 18[4] at 1[kV/cm]

More electrons / keV ?

or less ?

?

Faster electron drift ?

Slow hole(?) drift
Single directional Luke-
phonon?

Solid Xenon Project

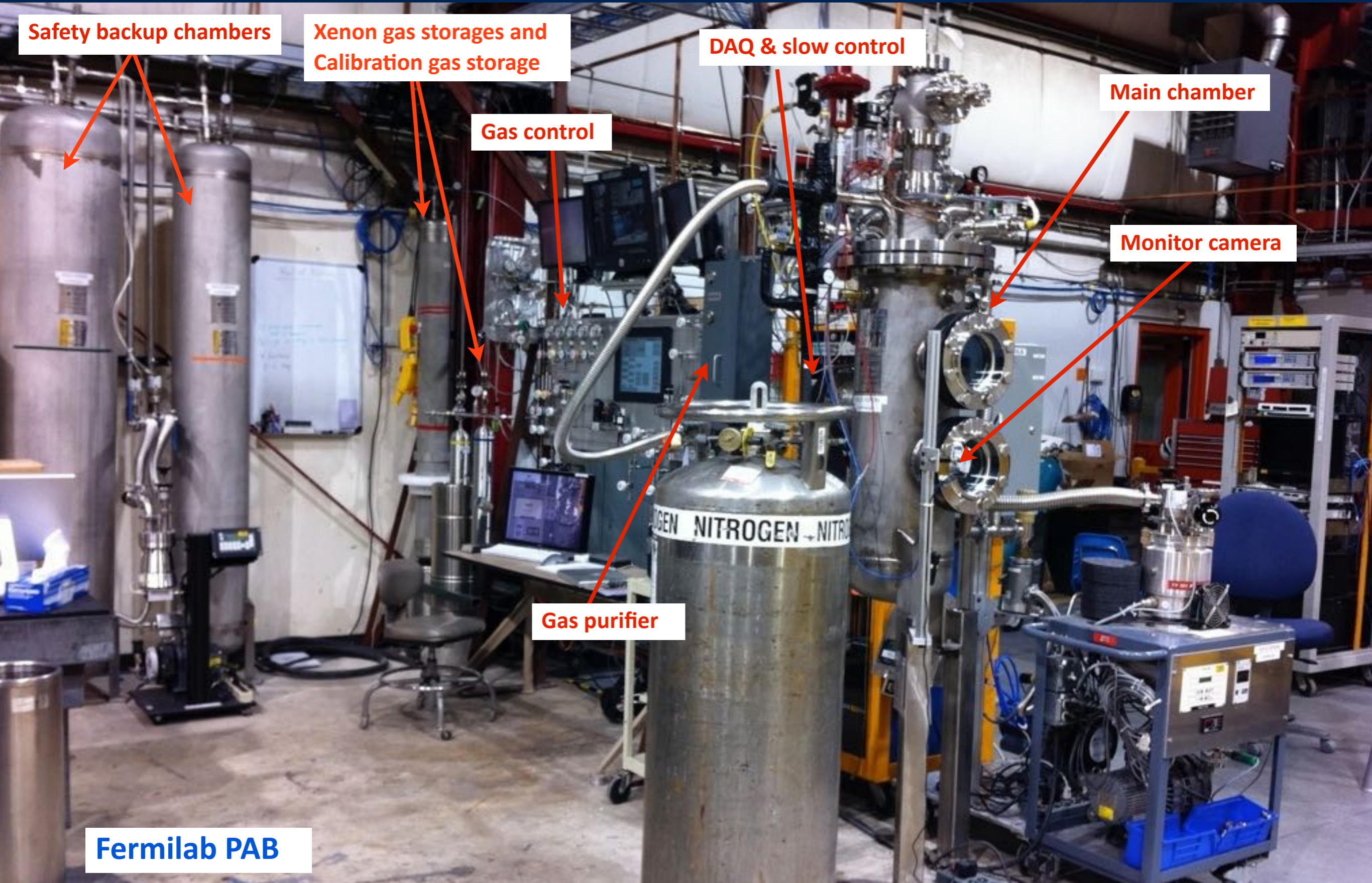

Fermilab PAB

Solid Xenon Project

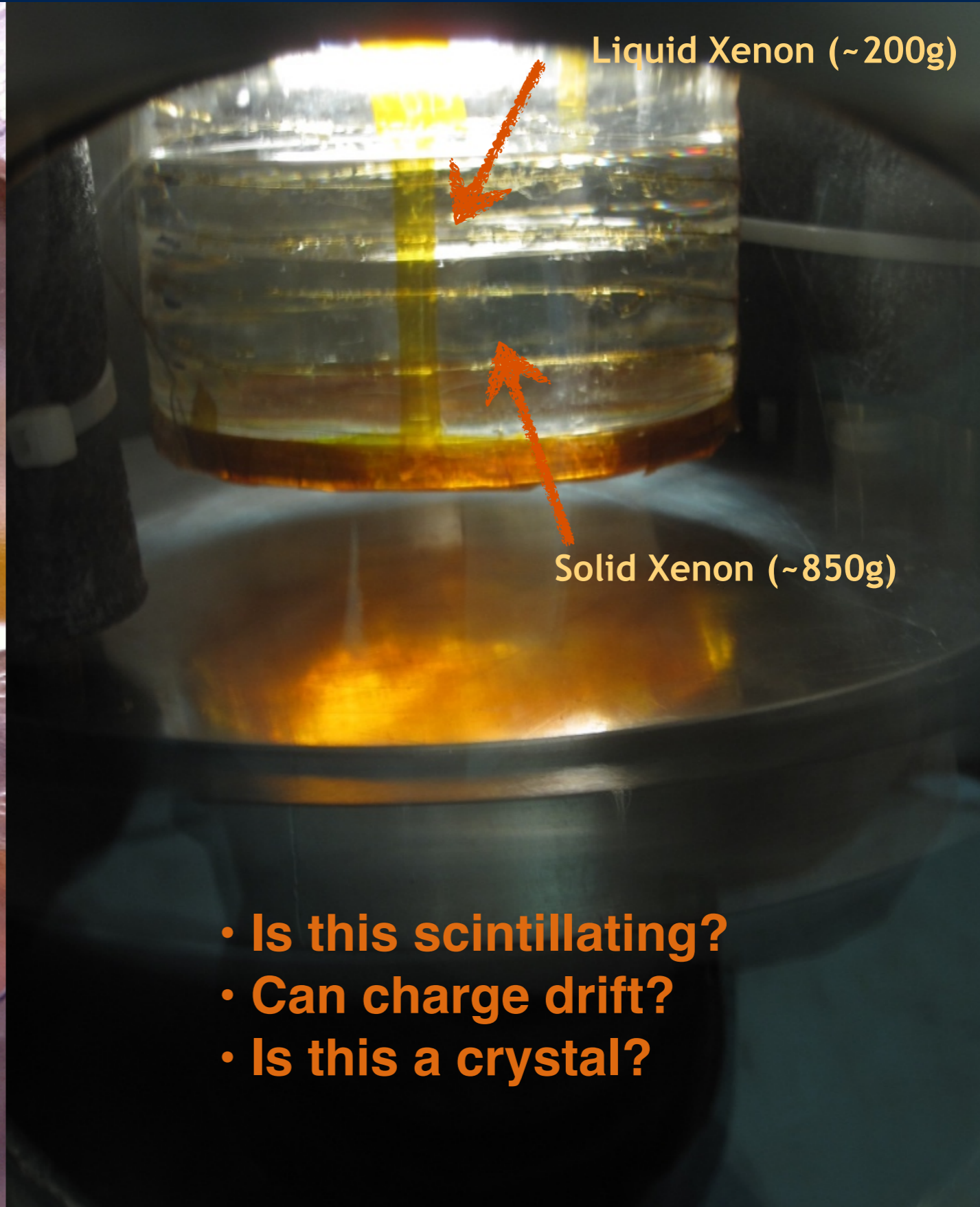
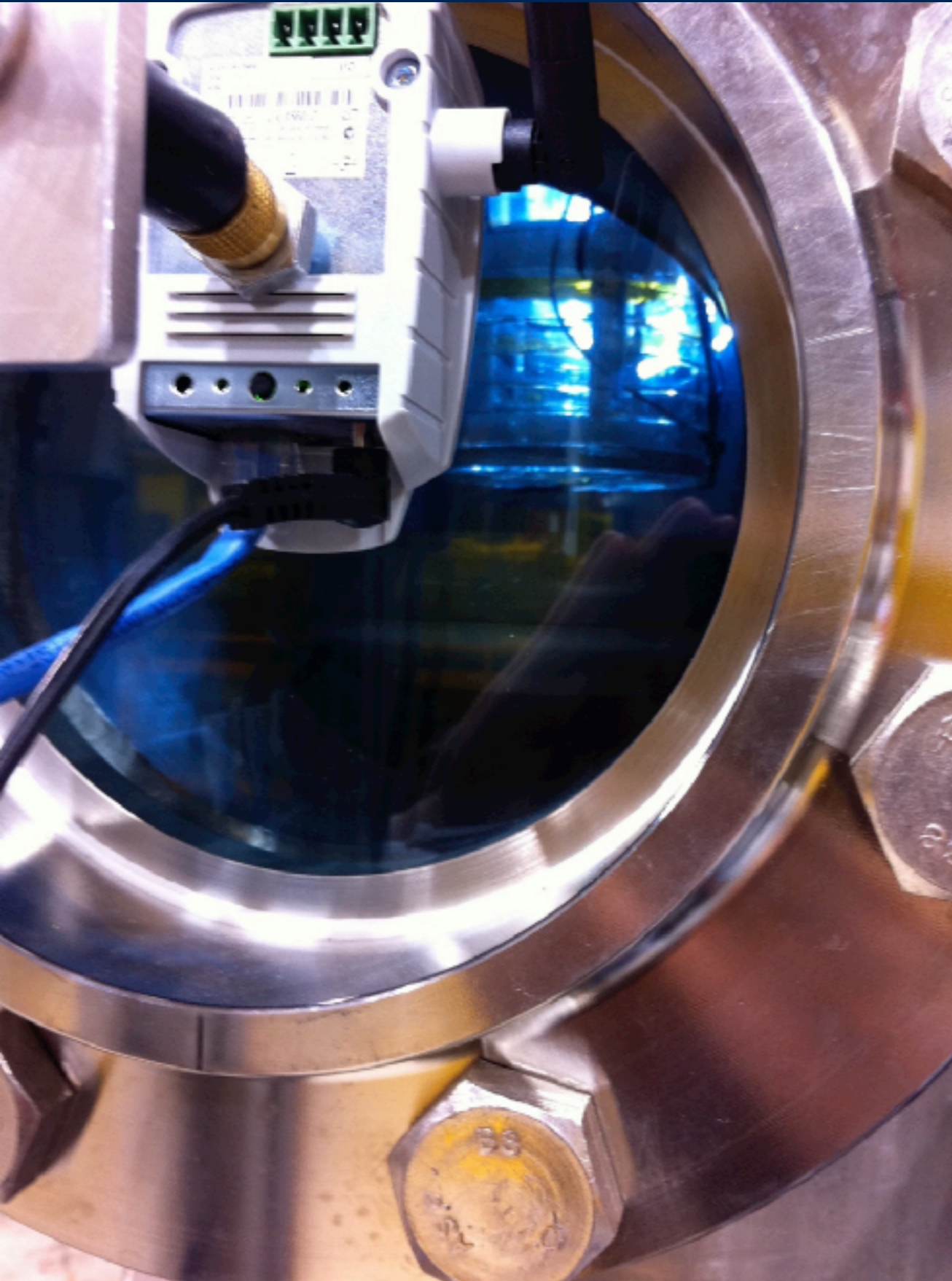

- Is this scintillating?
- Can charge drift?
- Is this a crystal?

Solid Xenon

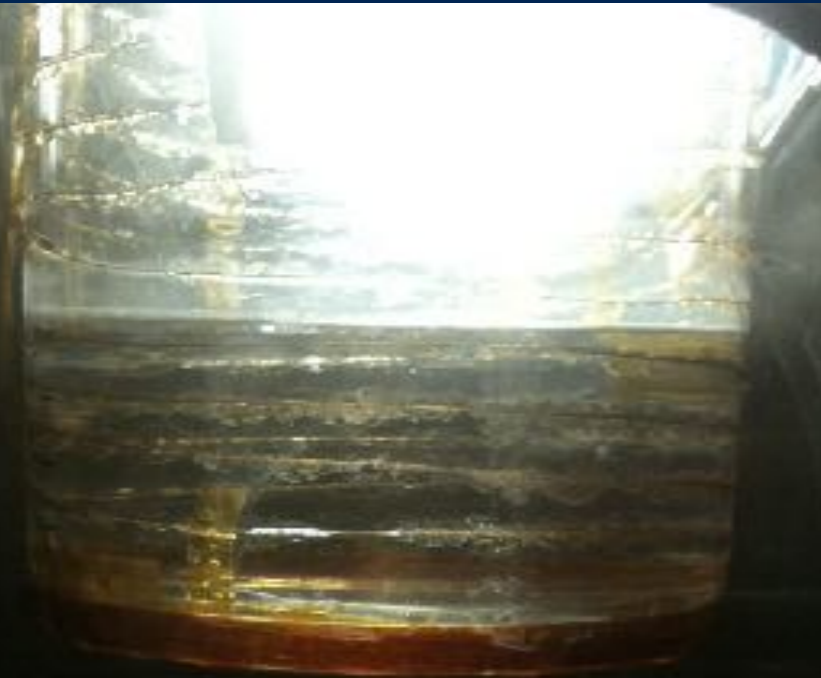

Liquid Xenon
Set temperature at 164K & 1atm



Frozen Xenon
Failure of temperature control



Frost Xenon
Failure of pressure control

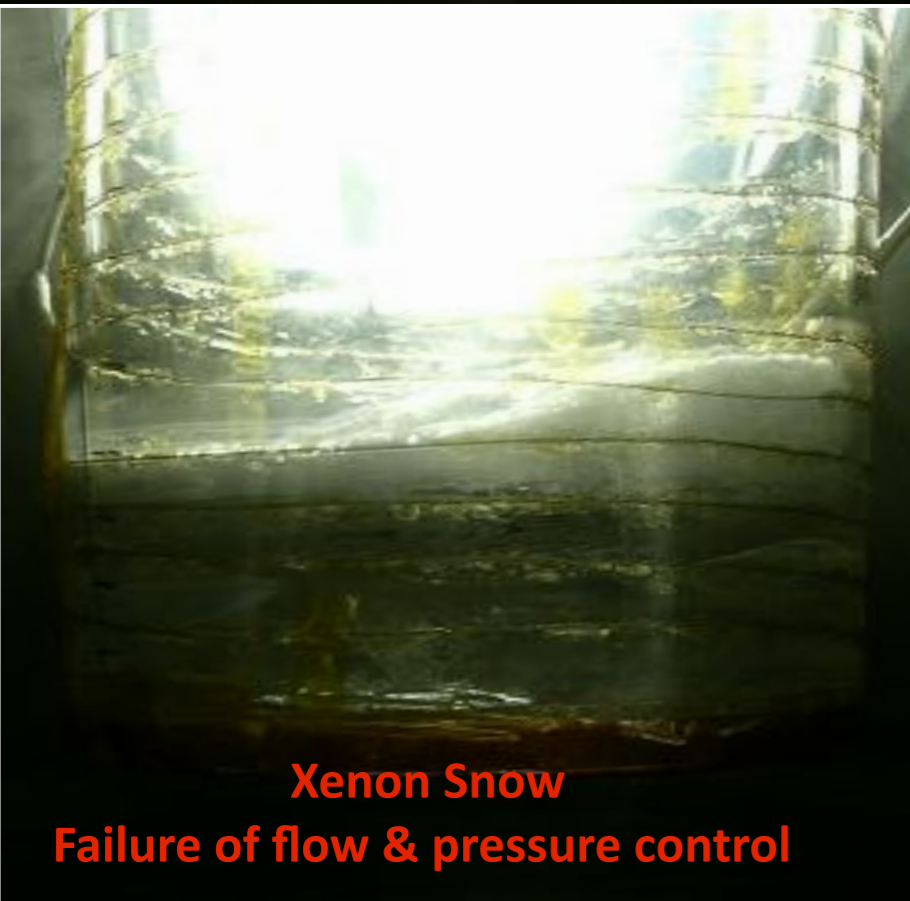

Xenon Snow
Failure of flow & pressure control



Polycrystalline Xenon
Failure of stability control (T&P)

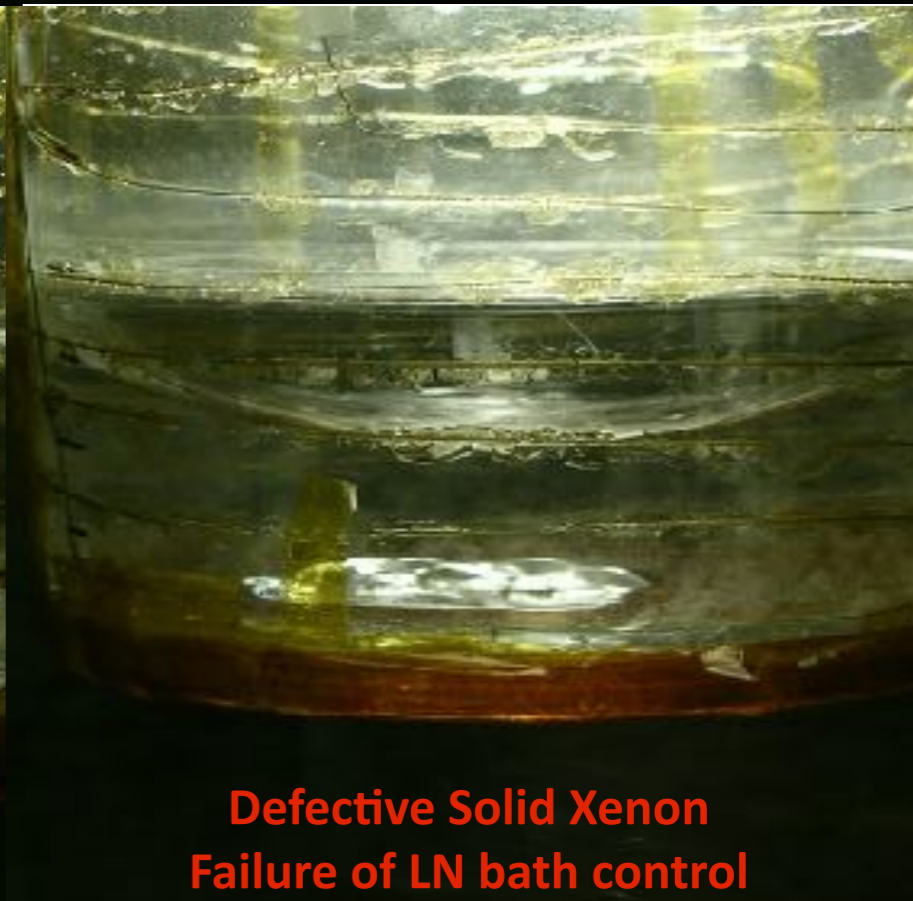

Defective Solid Xenon
Failure of LN bath control

Solid Xenon Scintillation

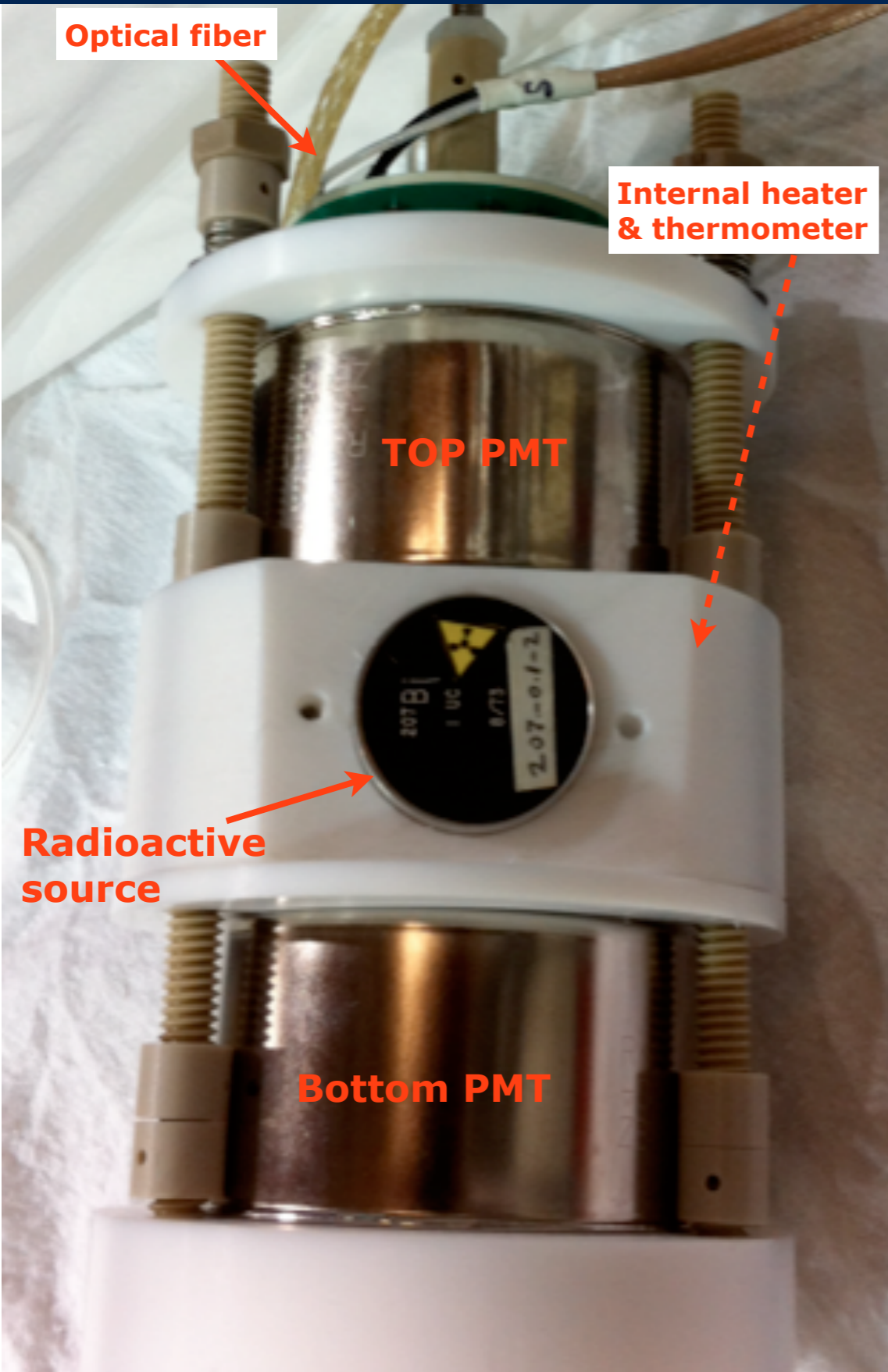

Single PE responses do not change

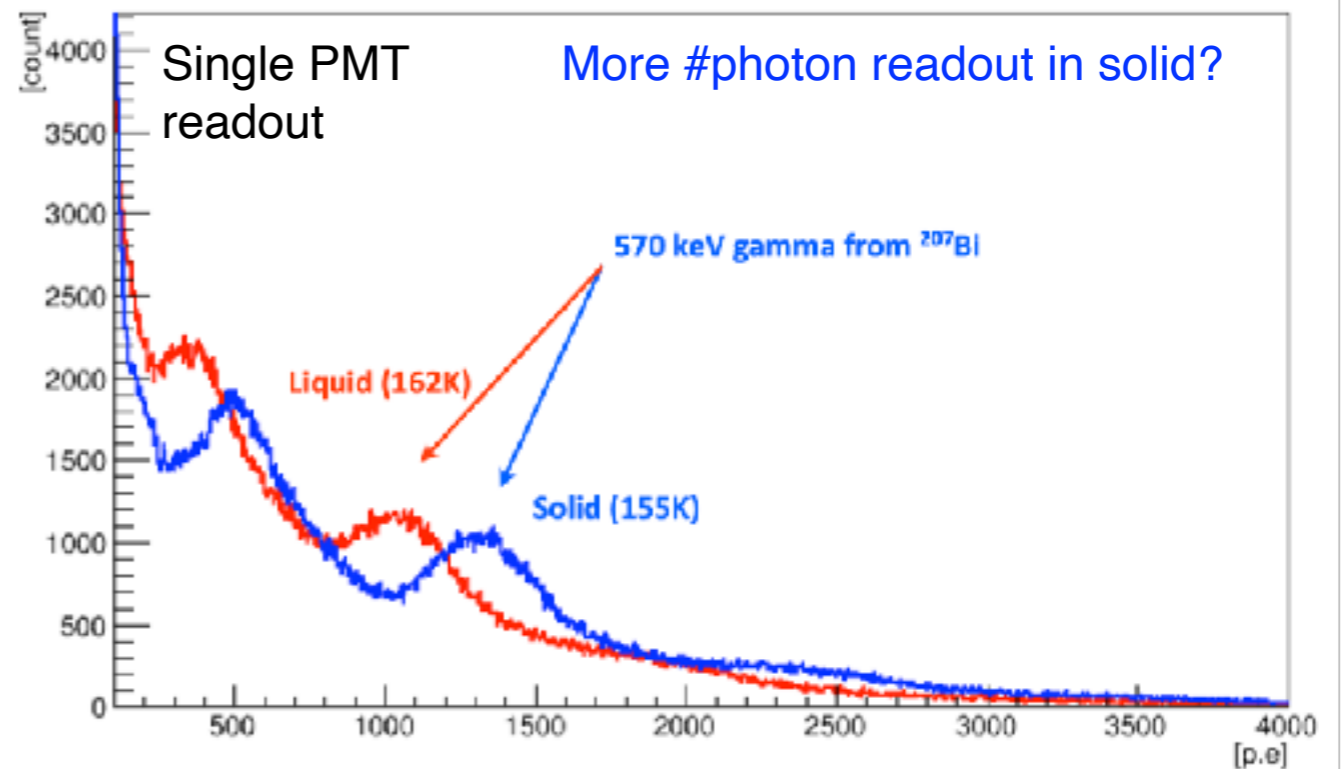
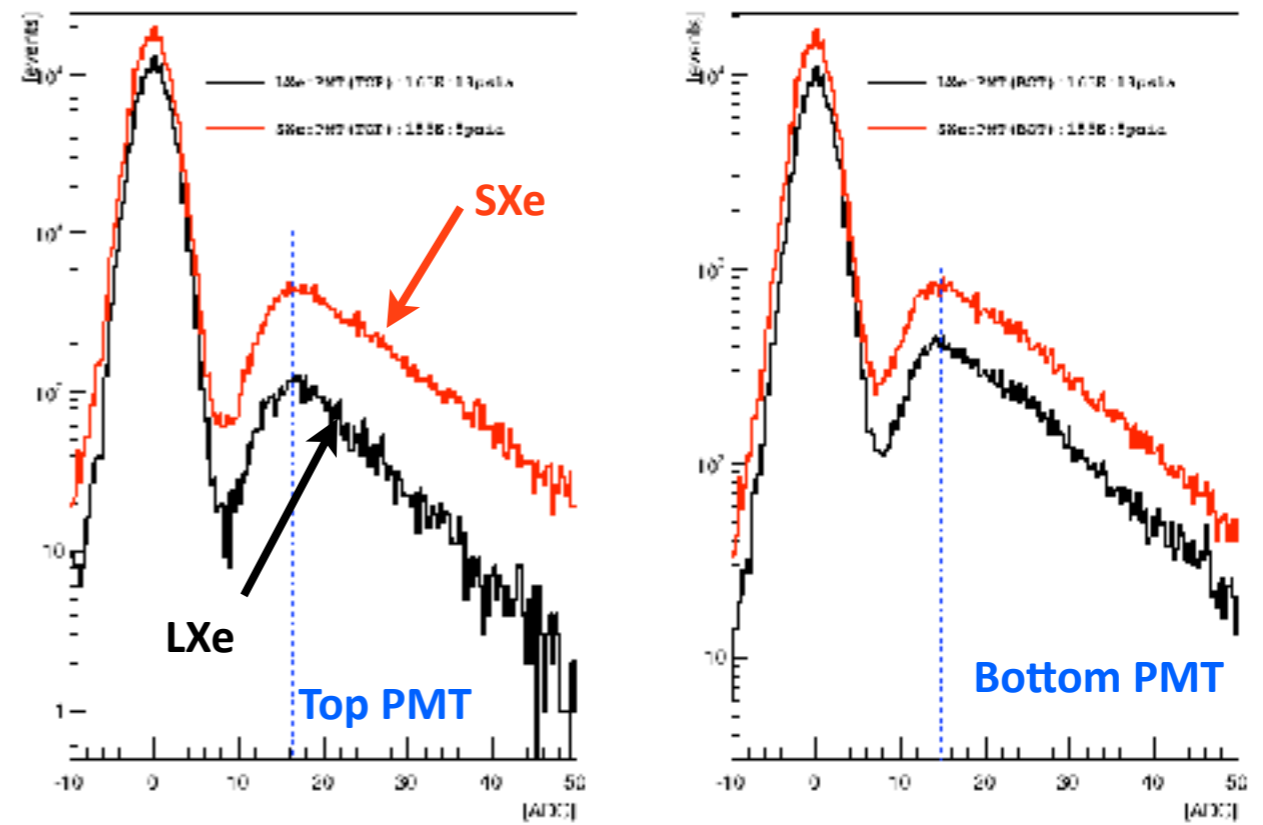

Solid Xenon TPC

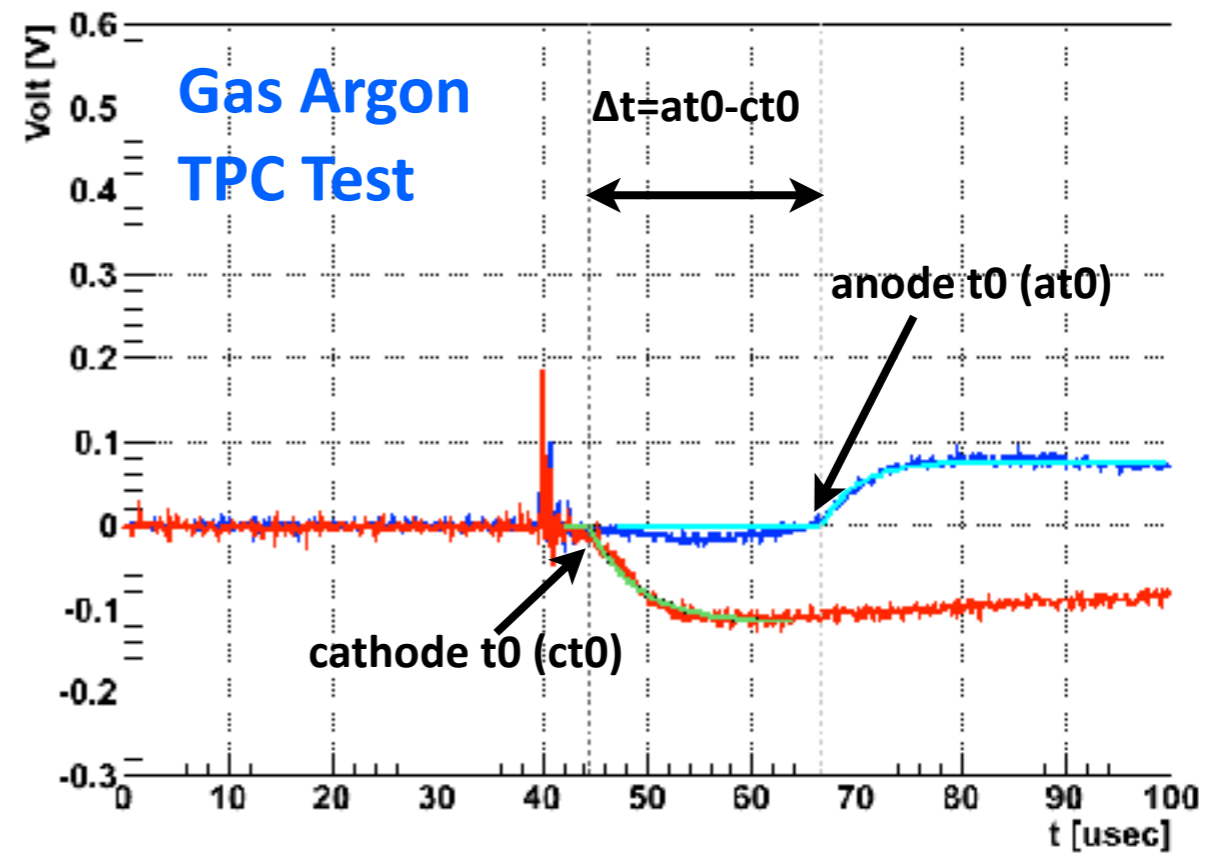
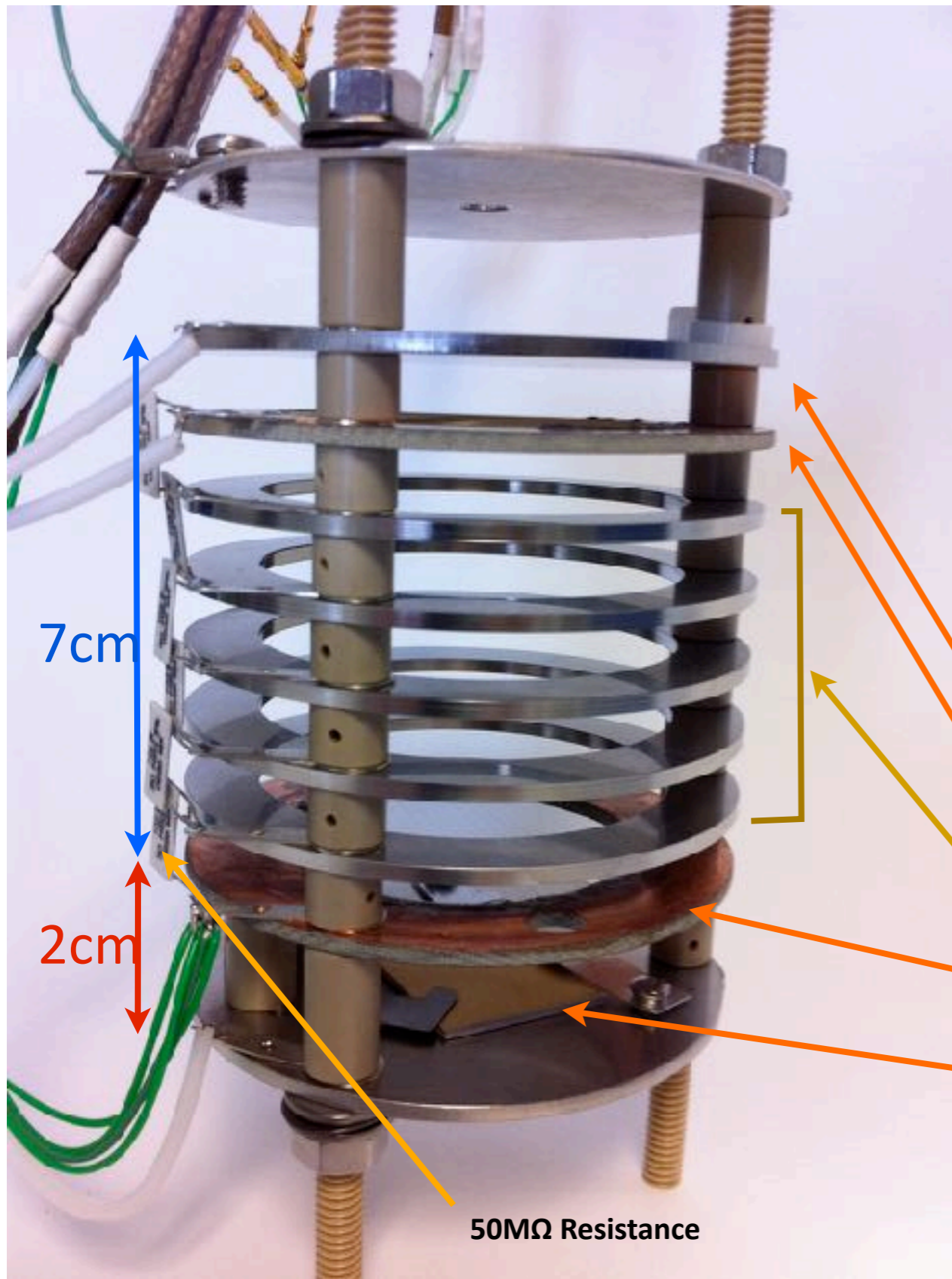

Solid Xenon TPC

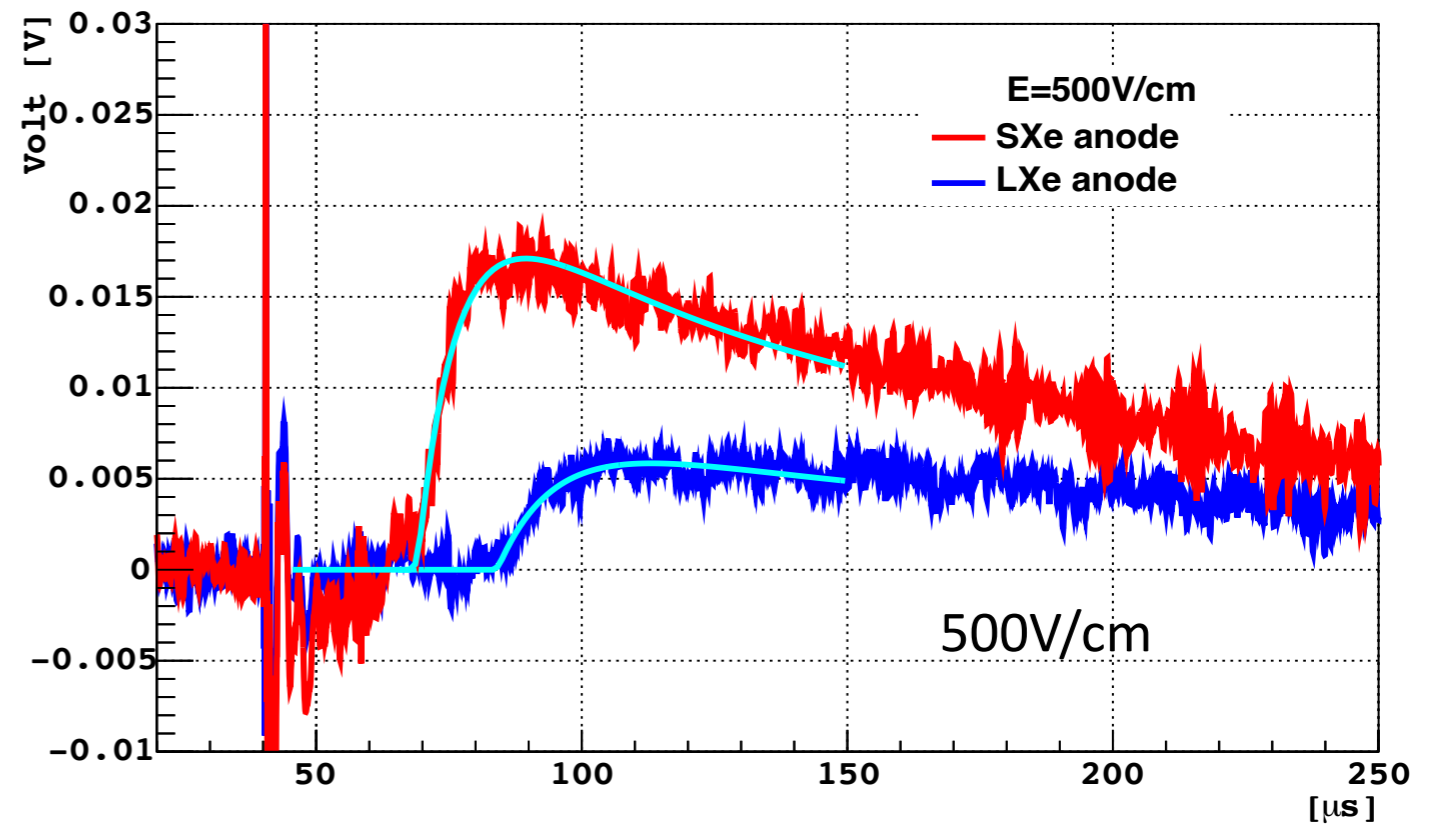
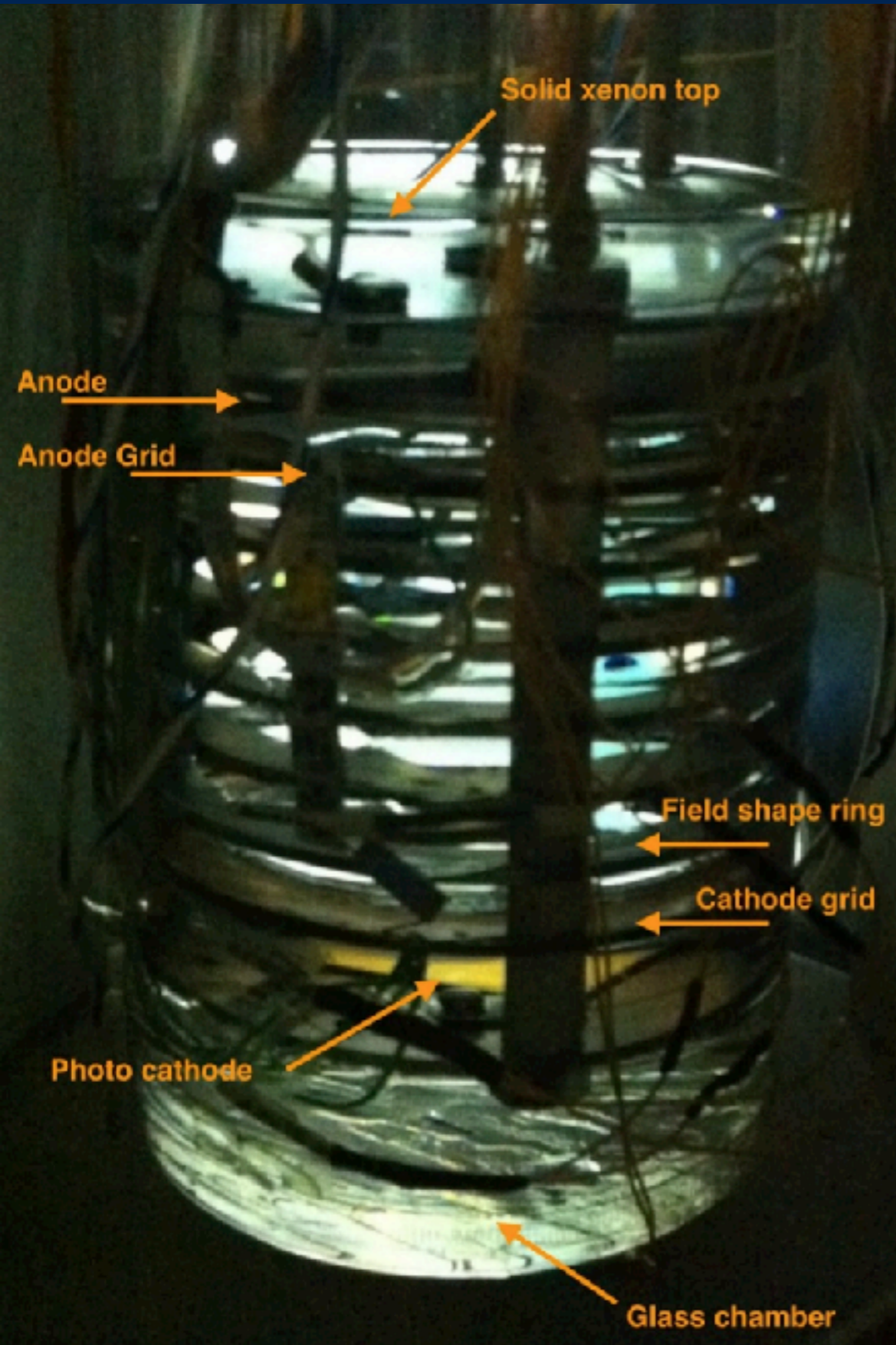

- 2.3kg optically transparent solid xenon demonstrated
(JINST 10 (2015) P04009)
- Electron drift distance: 8.7 cm
→ Longest electron drift in solid xenon!
Electrons drift 2x faster in solid xenon (157K)
compared to that in liquid (163K)
(JINST 10 (2015) P08011)

Solid Xenon TPC

JINST 10 (2015) 04, P04009

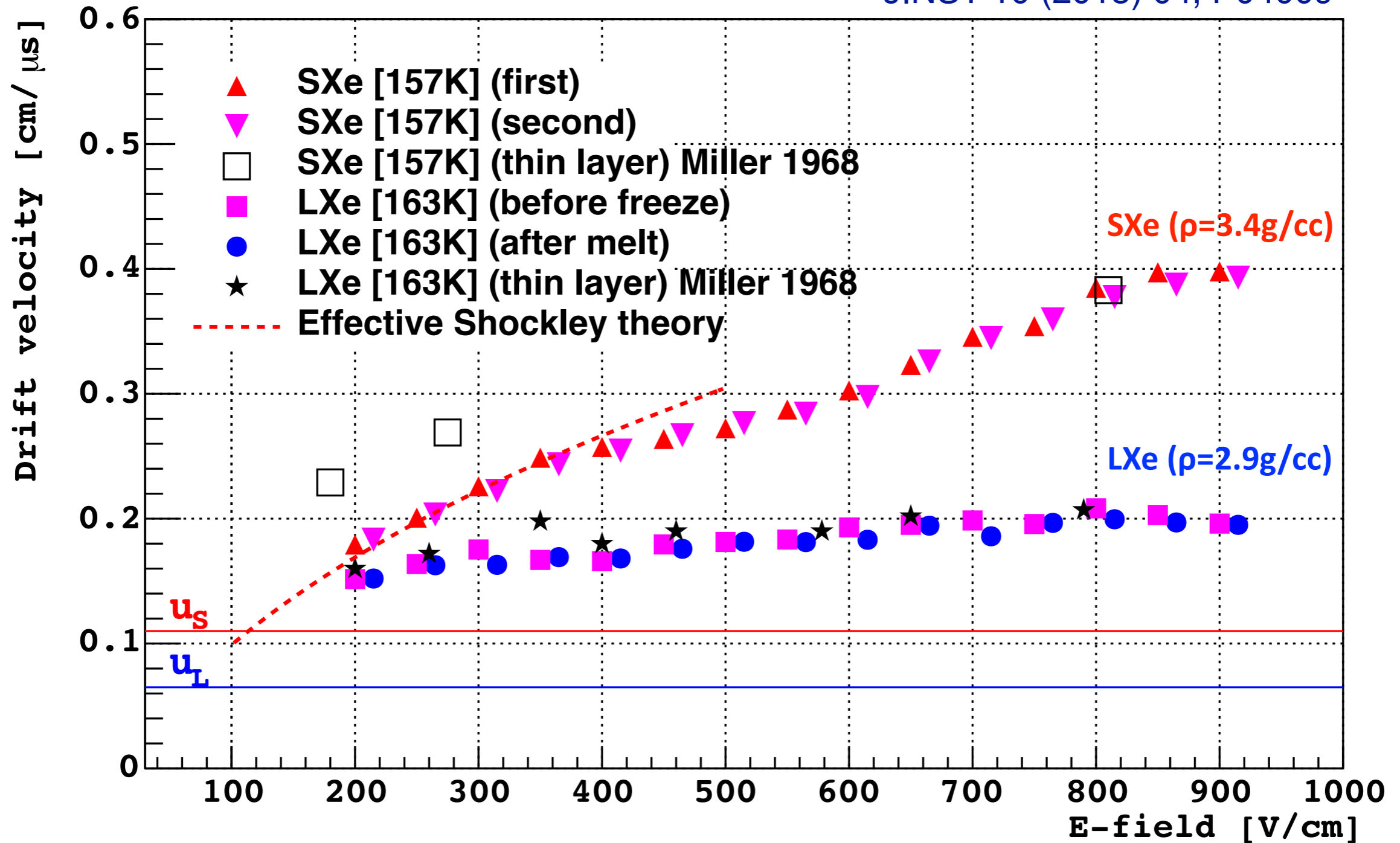

The scalability of solid xenon is the biggest issue!

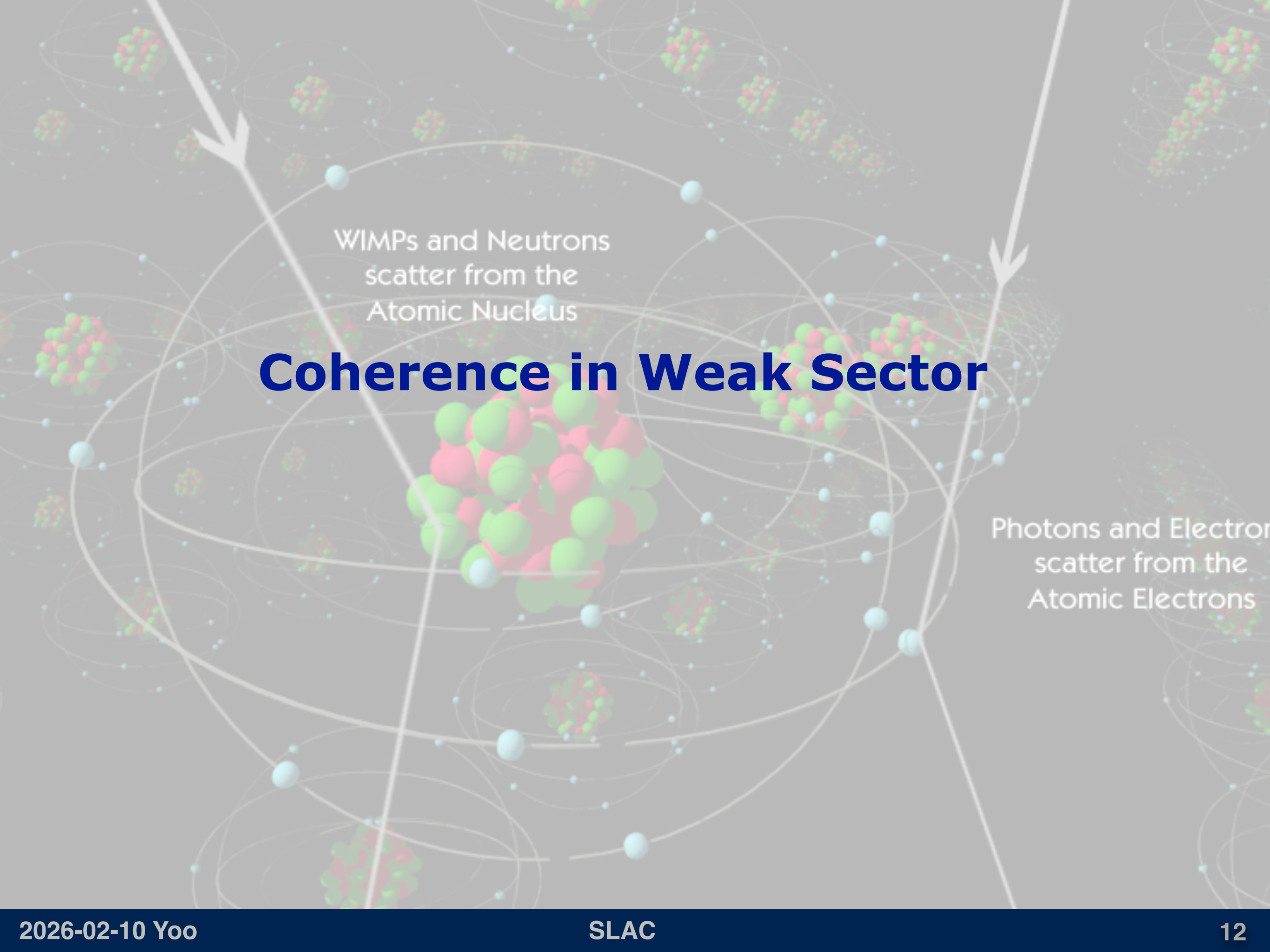

WIMPs and Neutrons
scatter from the
Atomic Nucleus

Coherence in Weak Sector

Photons and Electrons
scatter from the
Atomic Electrons

Direct Detection of Dark Matter

WIMPs (Weakly Interacting Massive Particles)
coherent scatter from the entire nucleus

WIMPs and Neutrons
scatter from the
Atomic Nucleus

Photons and Electrons
scatter from the
Atomic Electrons

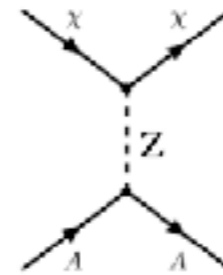

$$\sigma_{\chi N} \simeq \frac{4}{\pi} \mu^2 [Z f_p + (A - Z) f_n]^2$$

$$\frac{dR}{dE} = \frac{\sigma_0}{m_\chi} \frac{A^2}{2\mu_n^2} F_A^2(E) \times \rho_0 \int_{v_{\min}} \frac{f(v)}{v} dv$$

CEvNS Physics

- Largest cross sections in low-energy range: **small neutrino detectors**
- Clean SM predictions: **BSM sensitivity**
- Sensitivity to neutrino magnetic moment
- Sensitivity to measure Weak Mixing angle ($\sin^2 \theta_W$) at low energies
- Measurements of neutron formfactors: nuclear structure
- Nuclear reactor monitoring: non-proliferation application
- Precision flavor-independent neutrino flux measurements for oscillation experiments
- Sterile neutrino searches
- Sensitivity to study energy transport in supernovae
- Supernova neutrino detection
- Input for dark matter direct detection: precise determination of the neutrino floor

CEvNS

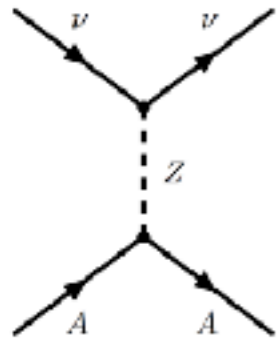

$$\mathcal{L}_{eff} = \frac{G_F}{\sqrt{2}} l^\mu j_\mu$$

$$\frac{d\sigma}{dT} = \frac{G_F^2 M}{2\pi} G_V^2 \left[2 - \frac{2T}{E_\nu} - \frac{MT}{E_\nu^2} \right]$$

$$G_V = [g_V^p Z F_p(Q^2) + g_V^n N F_n(Q^2)]$$

$$g_V^p = \frac{1}{2} (1 - 4 \sin^2 \theta_w) \quad g_V^n = -\frac{1}{2}$$

$$\sin^2 \theta_w \simeq 0.231$$

$$\sigma_{CEvNS} \simeq \frac{G_F^2}{4\pi} E_\nu^2 N^2 F_n(Q^2)^2$$

Coherence Condition

$$E_\nu < \frac{1}{R_N} \simeq 50 \text{ MeV}$$

Maximum recoil energy

$$T_{\max} \simeq \frac{2E_\nu^2}{M}$$

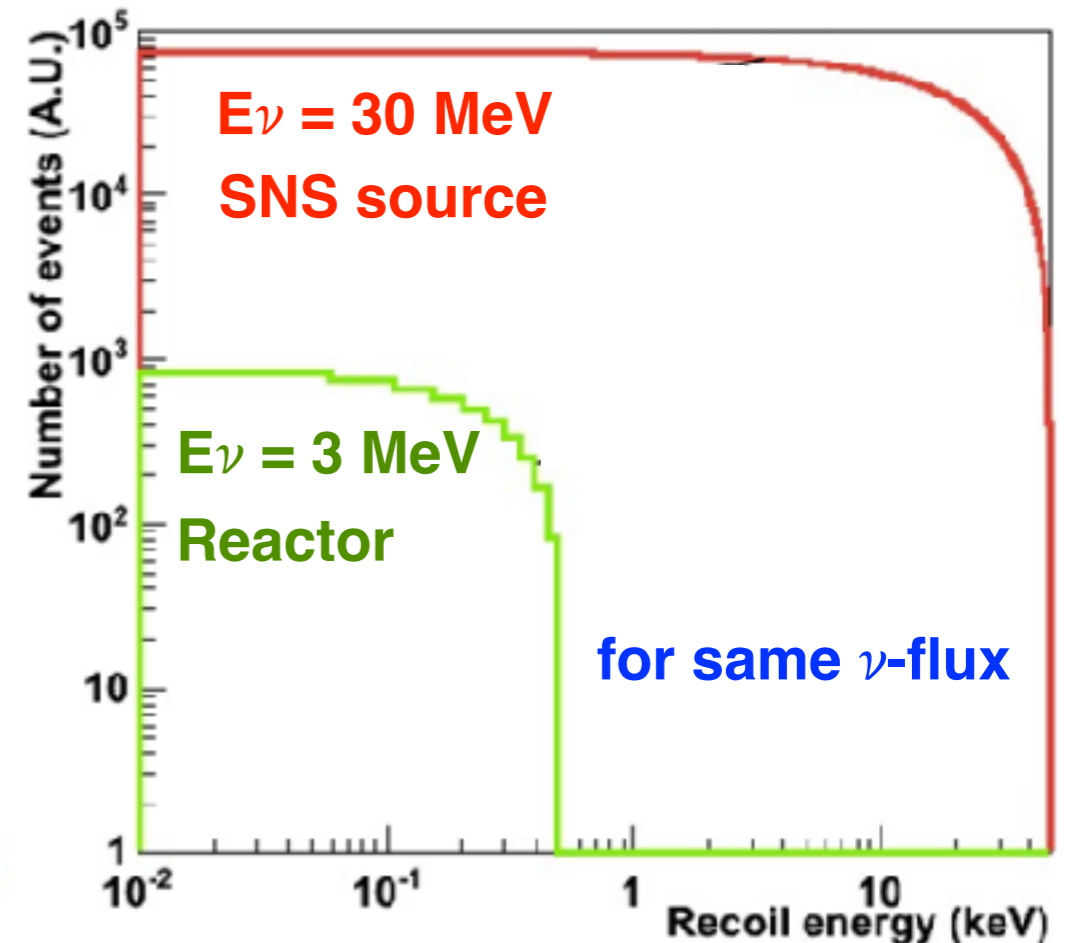
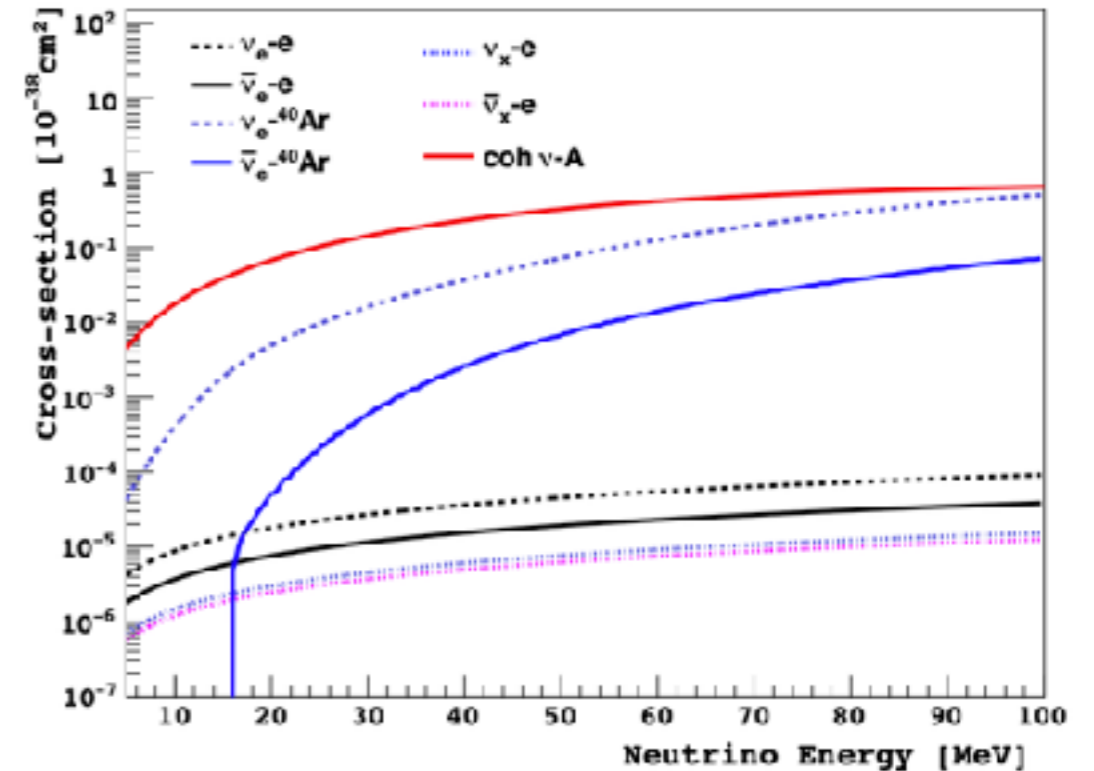

Reactor CEvNS

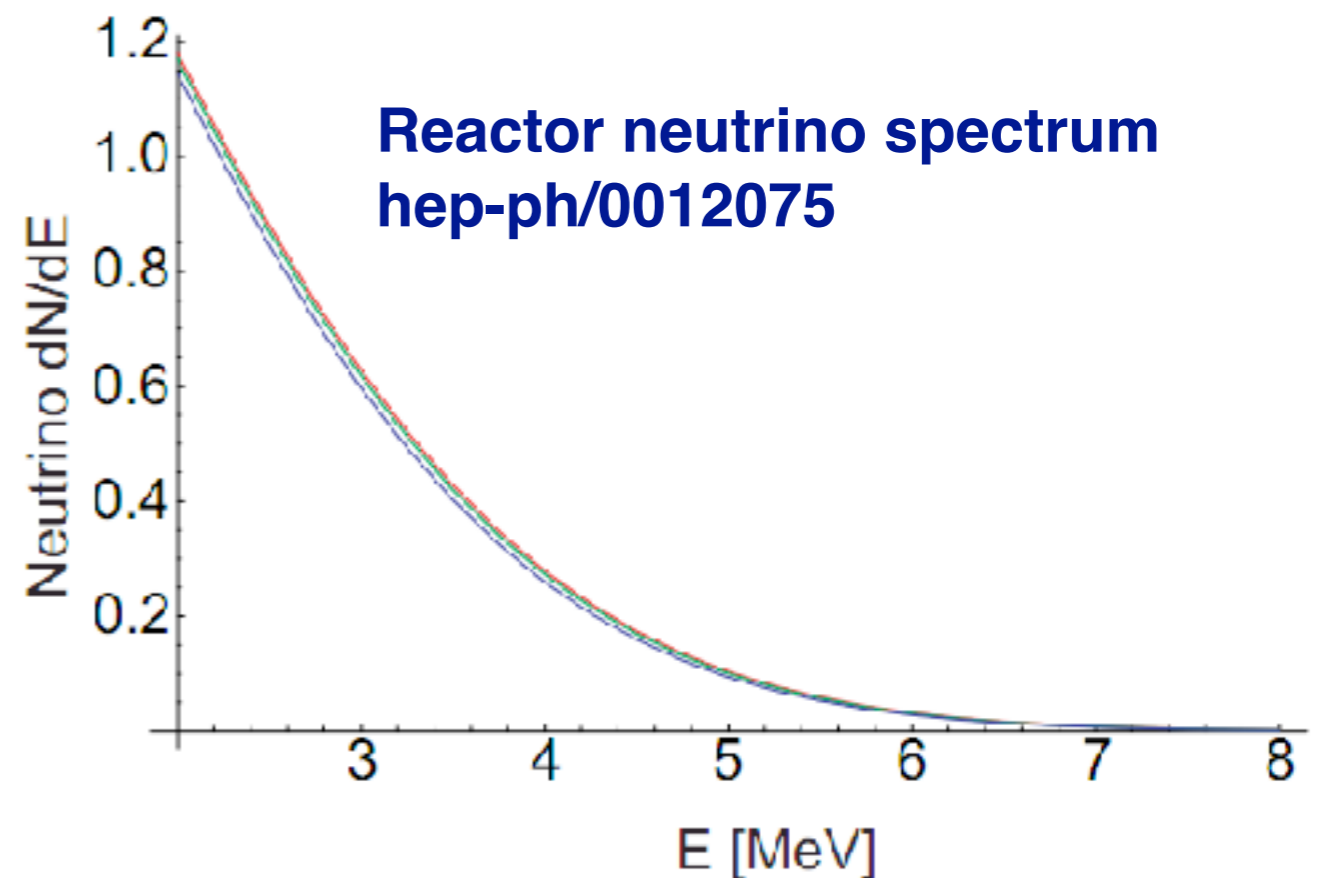

$$E_{max} \simeq \frac{2E_{\nu}^2}{M} < \text{keV}$$

$$\Phi = 10^{20} \bar{\nu}_e / \text{sec} / 4\pi R^2 \quad (\Phi = 10^{12} \bar{\nu}_e / \text{sec} / \text{cm}^2 @ 20 \text{ m})$$

- **Requires Ultra-clean, kg-size, sub-keV threshold detector**
- Need to overcome steady state backgrounds and detector noise
- Reactor off-time can be used for background subtraction
- Detector development is very challenging for a realistic experiment

Neutrino Source @ Fermilab



Fermilab Booster Neutrino Beam

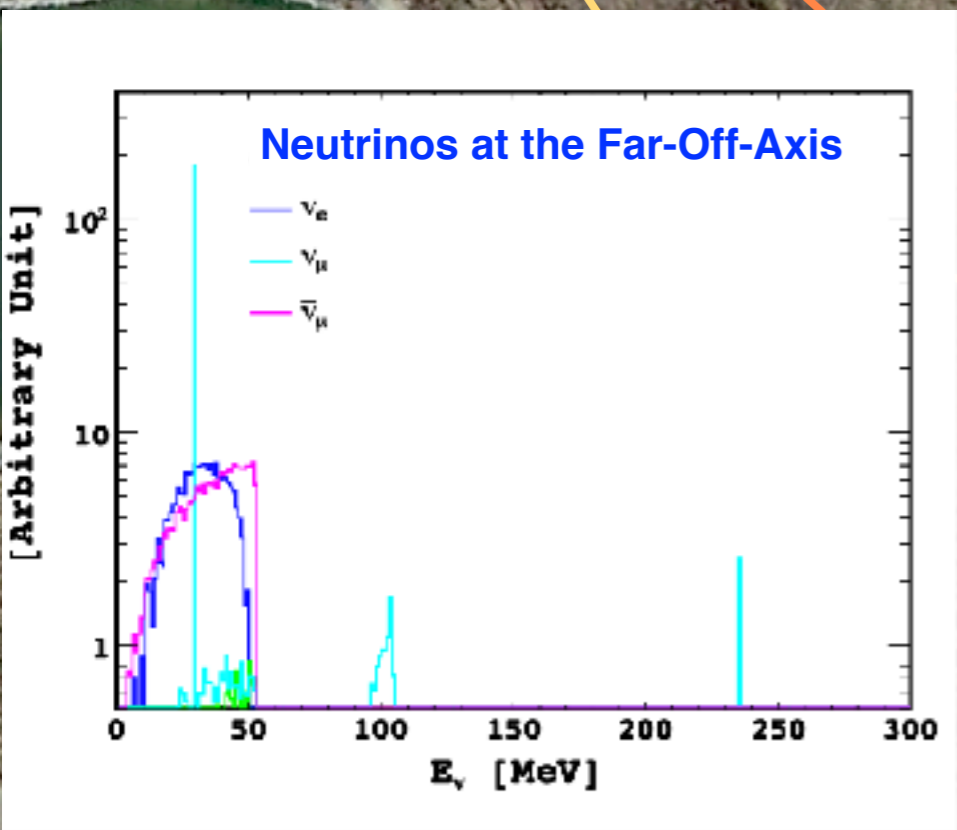
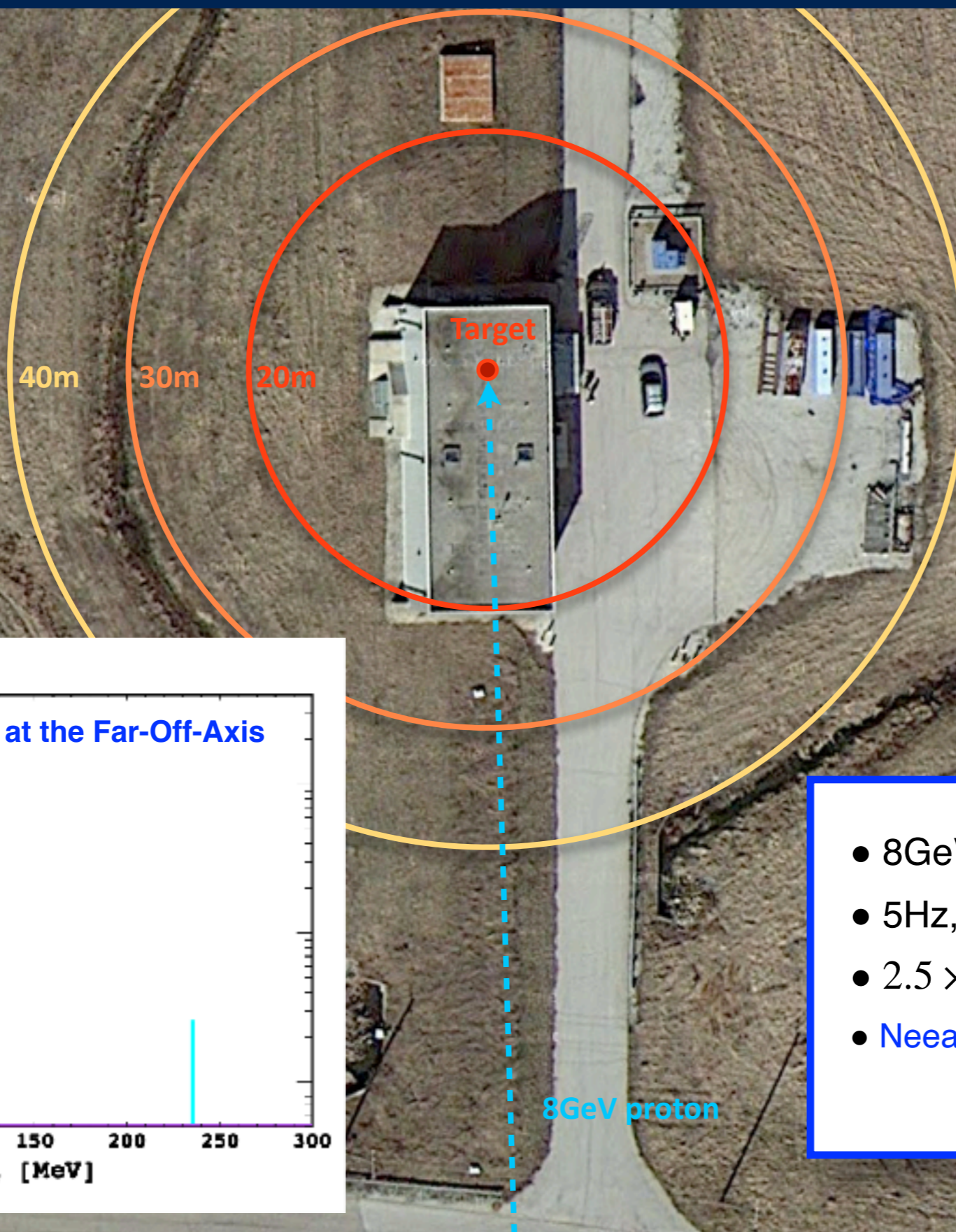

- 8GeV proton beam on Be target
 - 5Hz, 5×10^{12} POT
 - $2.5 \times 10^6 \nu/cm^2/s$ @ 20m from target
 - Nee a ton-scale CEvNS detector
- PRD 89, 072004 (2014)

Argon

- **Pulse-Shape Discrimination (PSD):** A single-phase LAr shows different excitation between ER & NR
 - **PSD performance:** rejection power 10^8 , leakage rate of ER events to NR range 10^{-8}
 - **Electron Recoils induce mostly triplet excitation:** $3p \rightarrow 4p$ $\tau_t = 1600 \text{ ns}$
 - **Nuclear Recoils induce mostly singlet excitation:** $3s \rightarrow 4s$ $\tau_s = 6 \sim 8 \text{ ns}$
- **Abundance:** Argon makes up about 1% of Earth's atmosphere
- **Transparency:** Argon is transparent to its own 128 nm scintillation light
- **Drawback:** ^{39}Ar (beta decay rate $\sim 1\text{Bq/kg}$, $T_{1/2} = 268 \text{ yr}$) \rightarrow induce Electron Recoil events
- **Underground Argon (UAr):** UAr in a CO_2 well in Colorado, the ^{39}Ar activity was 1/1400 compared to AAr

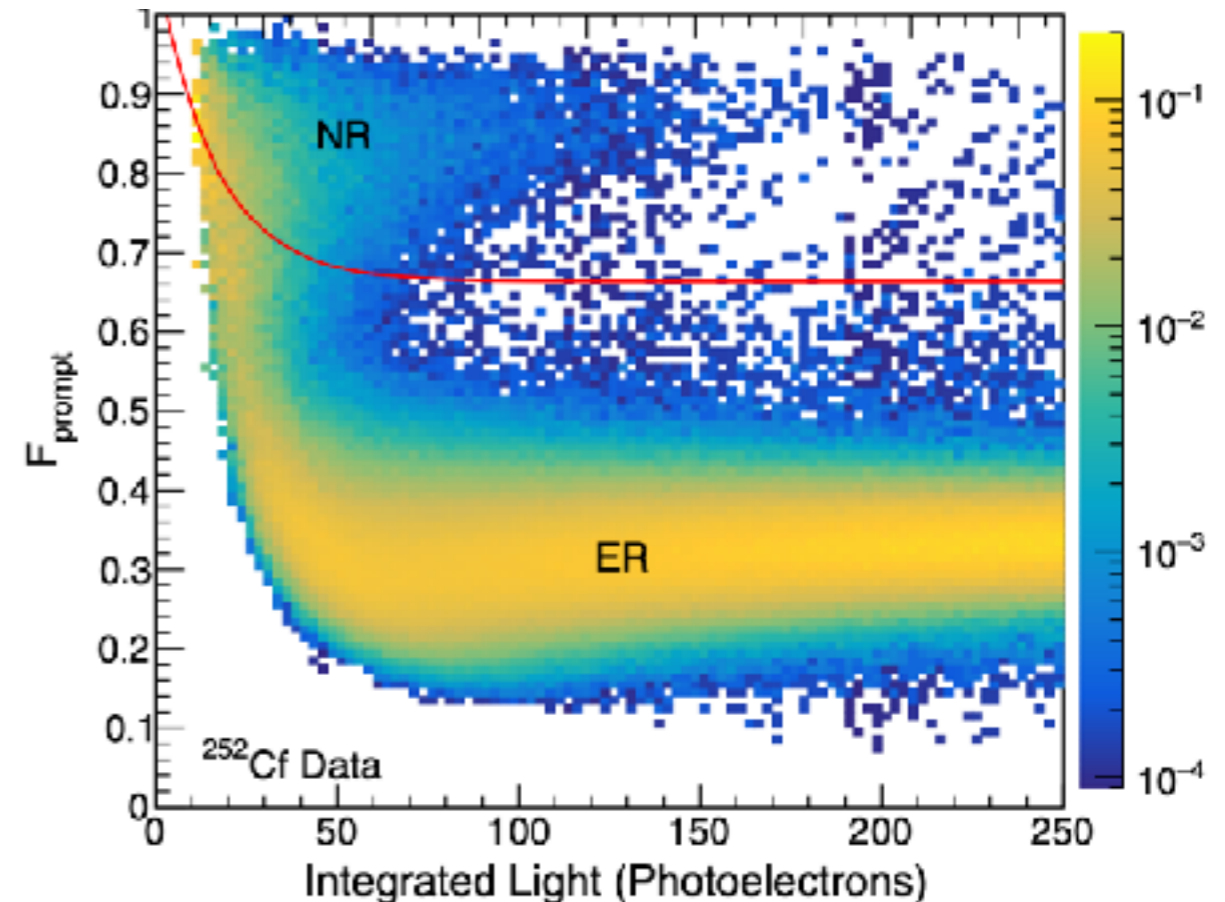
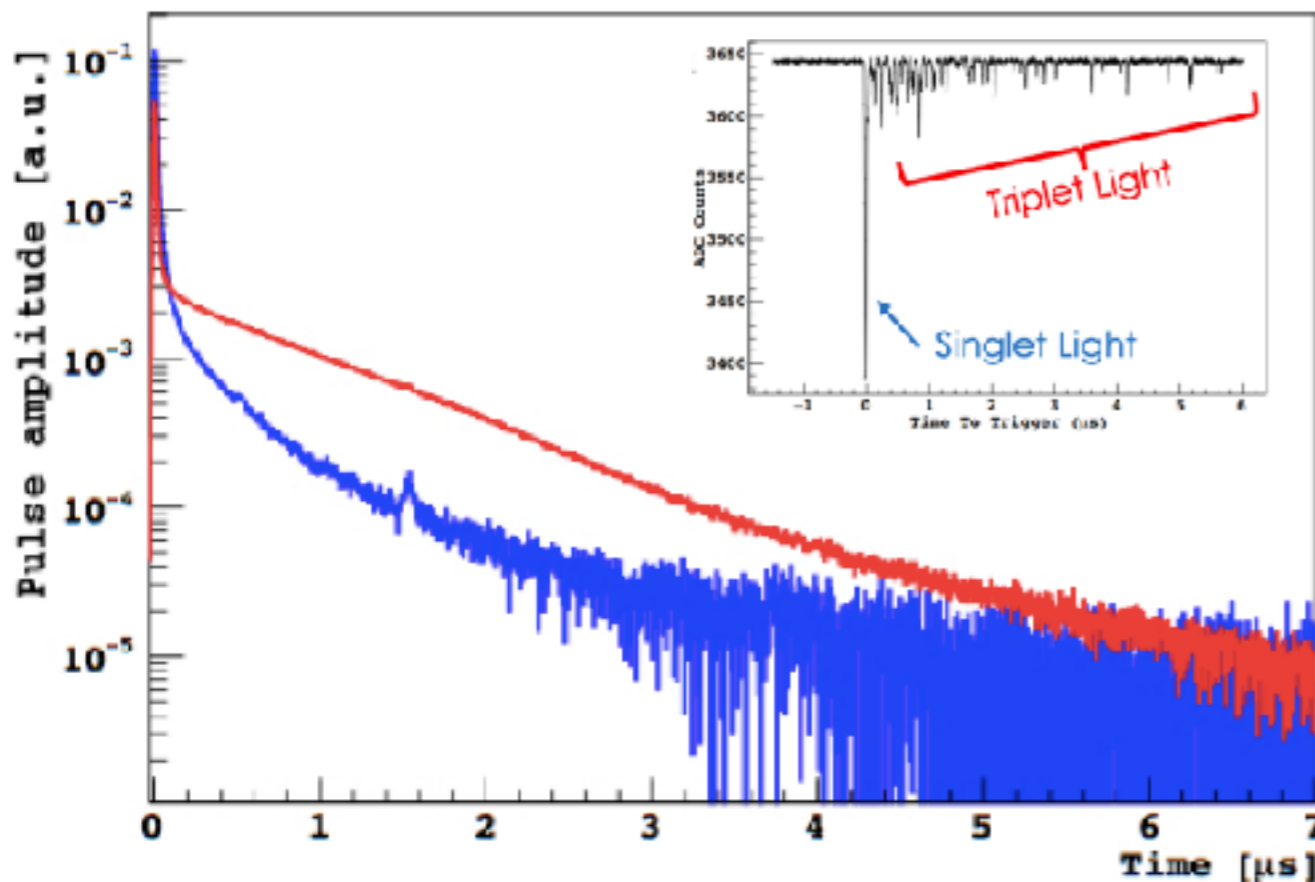

CENNS Project

Low background single-phase liquid argon scintillation detector

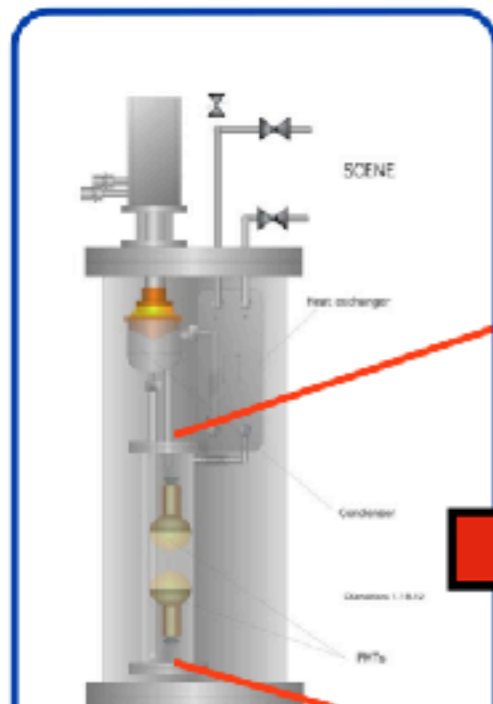

1-kg detector 2012

- Operational experience
- Measure scintillation light efficiency of nuclear recoils in LAr

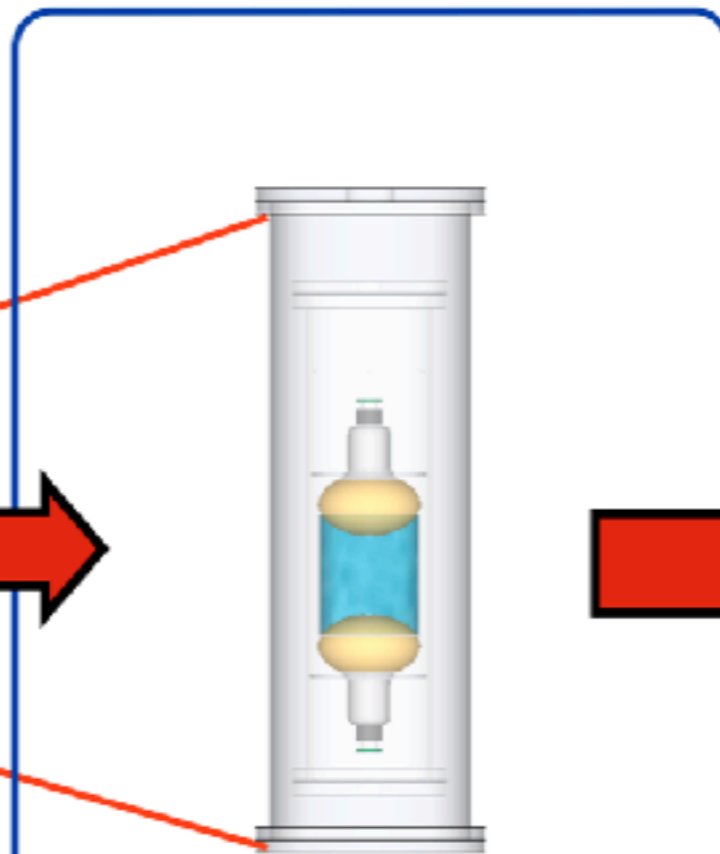

10-kg detector 2013~2014

- Study beam induced neutron shielding near the beam target
- Characterize the BNB neutron backgrounds in LAr target
- Understand design issues of the ton-scale detector (LAr detector test stand)

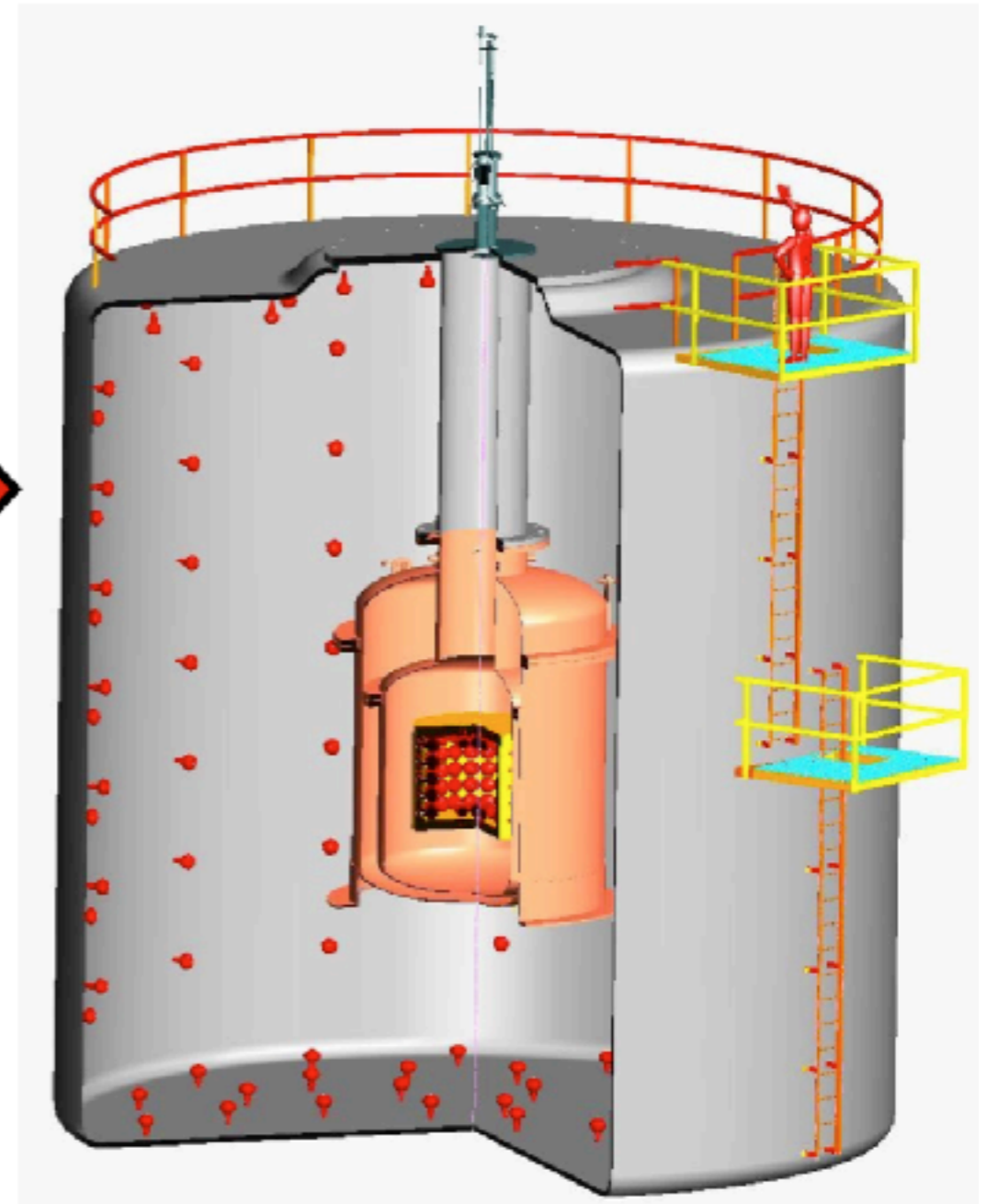

Ton-scale detector for the CENNS experiment

LAr Detector R&D: 1kg Detector

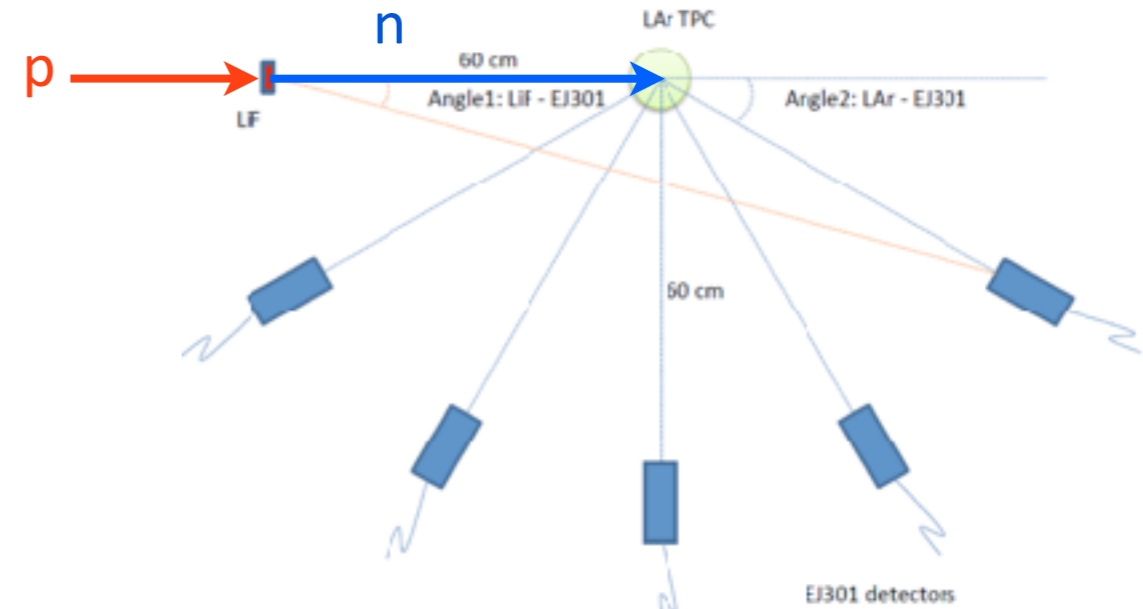
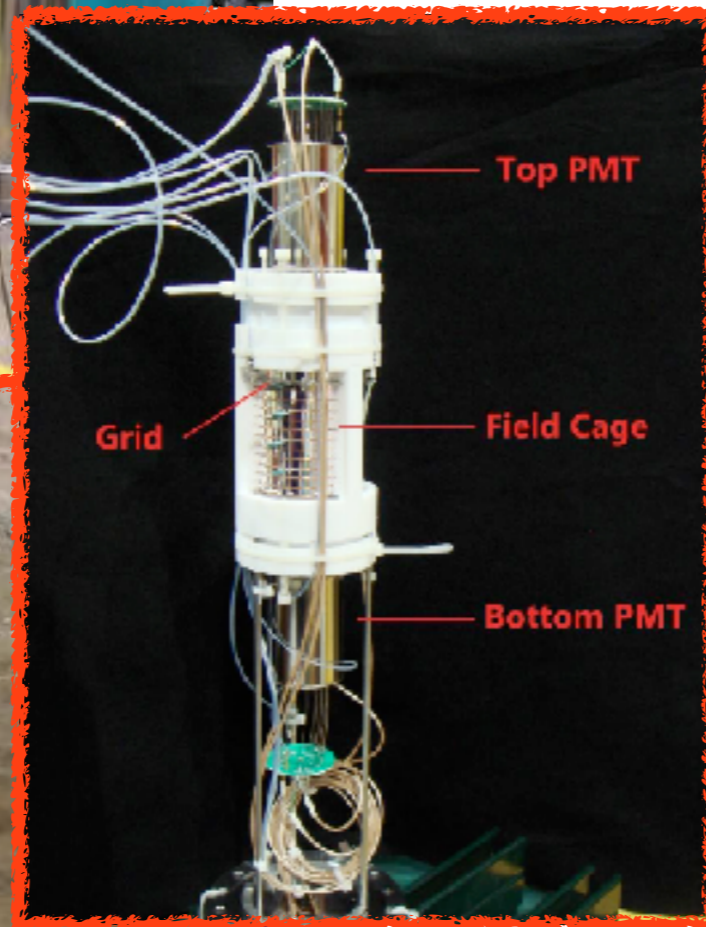
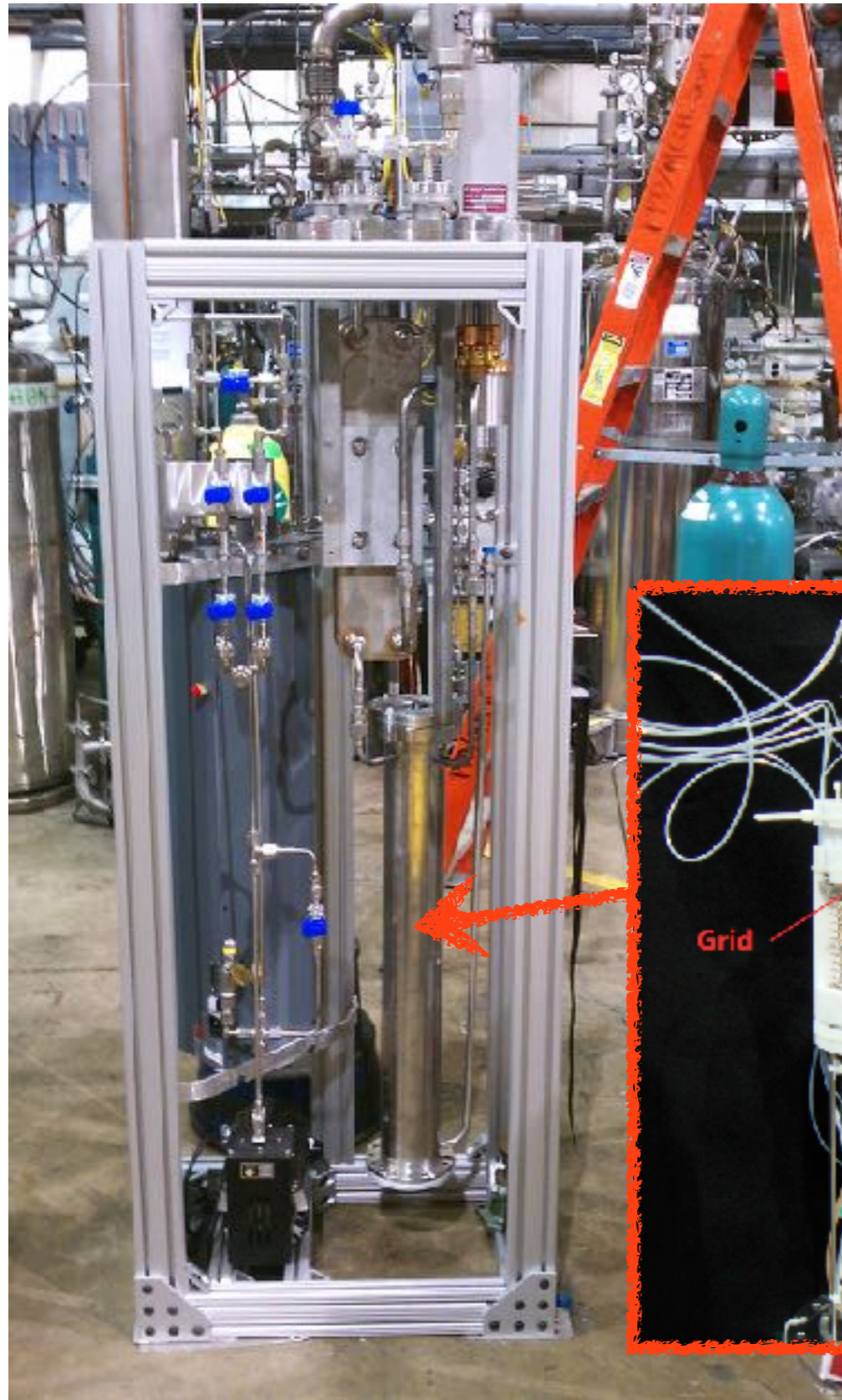

Proof of the detector principle

- Test both [single-phase](#) and dual-phase TPC
- Measure scintillation light yield in low-energy (< 50 keV) nuclear recoils
- Use pulsed neutron beam at U. Notre Dame
- PRD 91, 092007 (2015)



1kg Detector Performance

Gamma Light Yield (single phase)

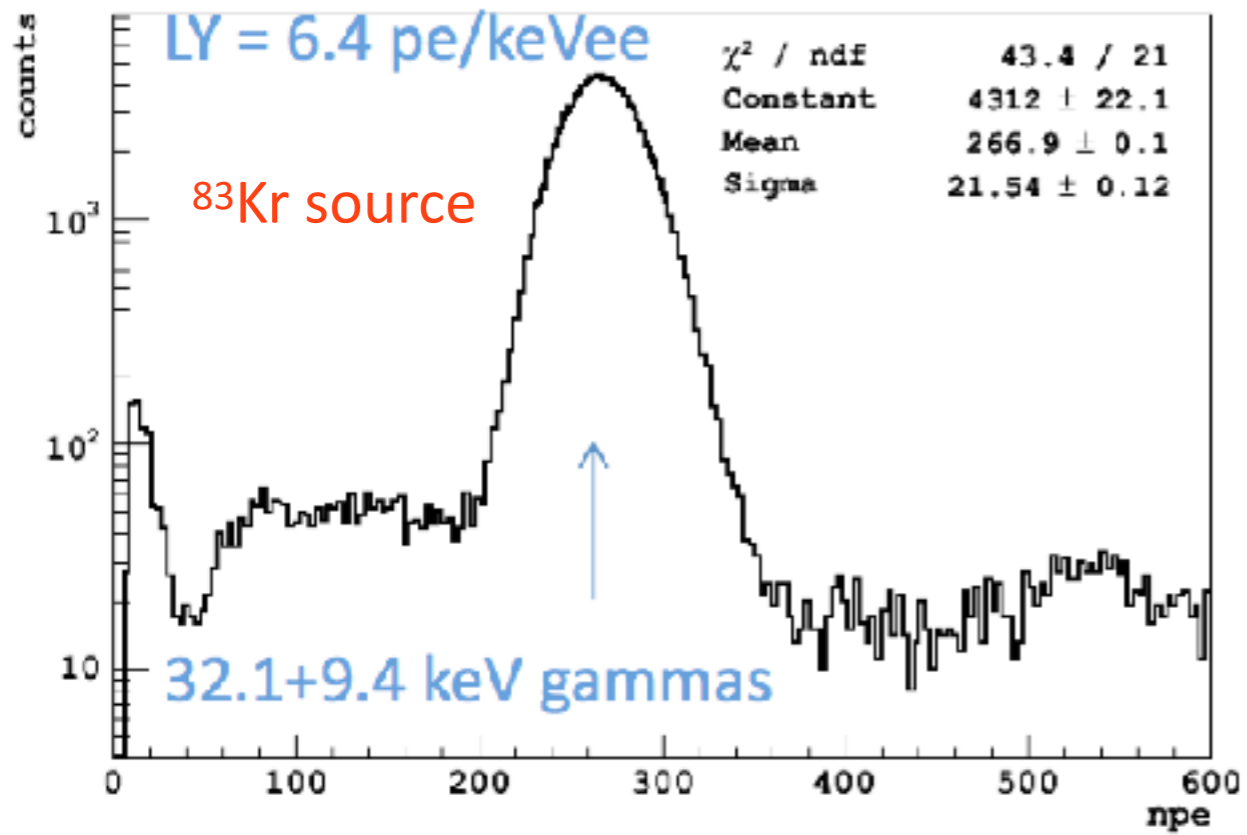

Pulse Shape Discrimination

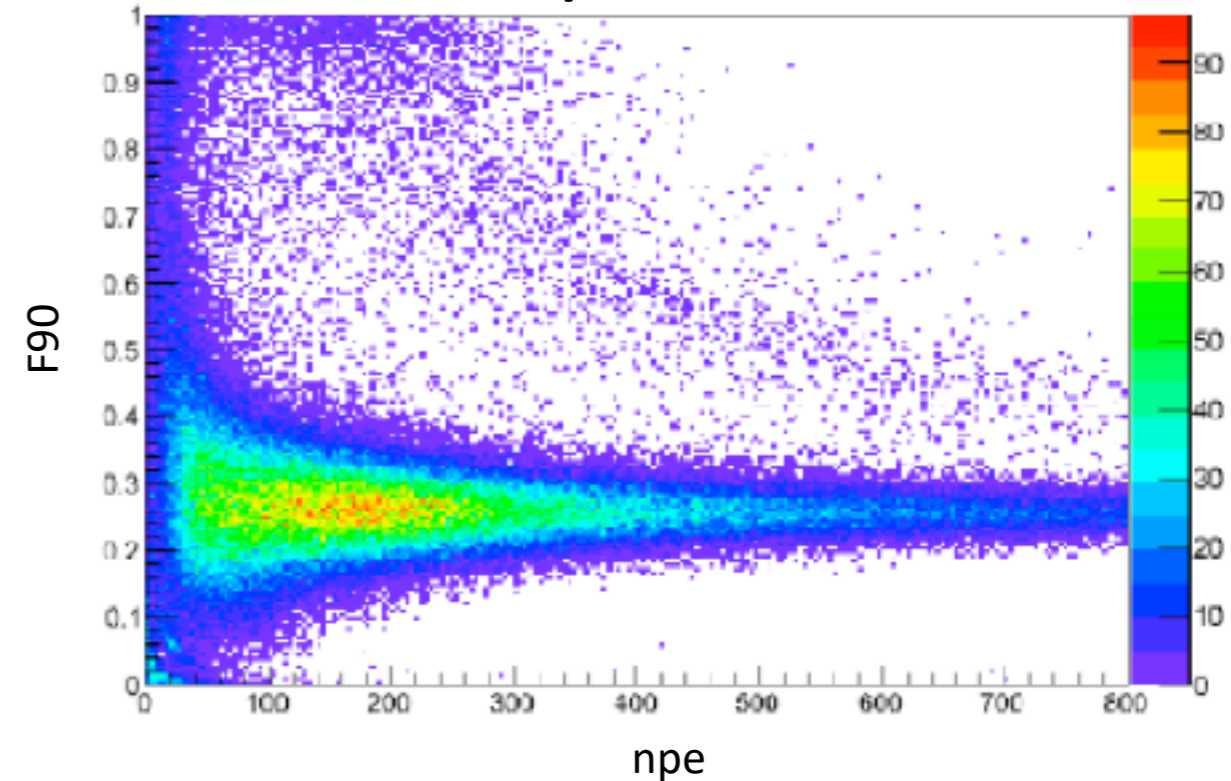

Electron Drift time (145us)

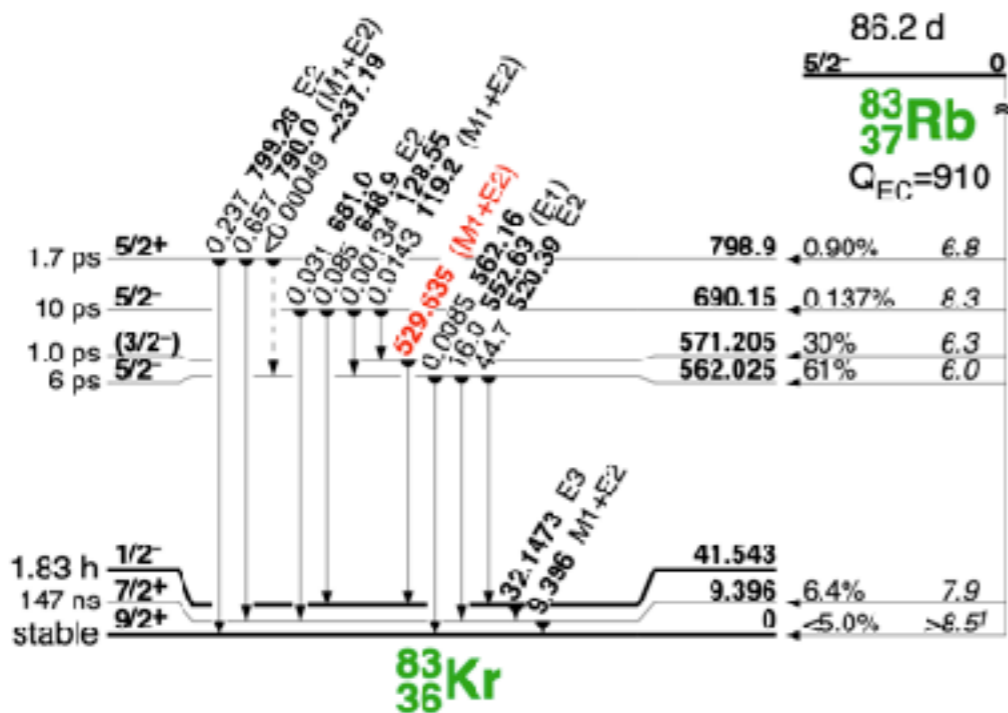
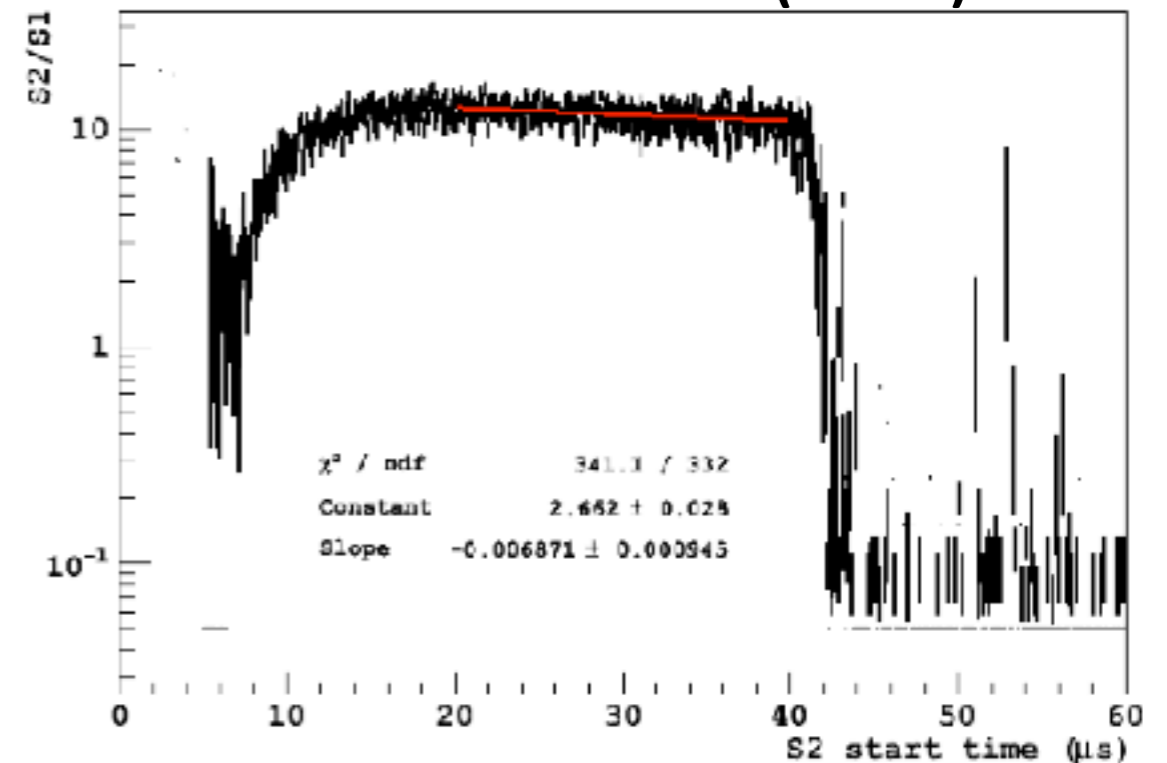

LAr Detector R&D

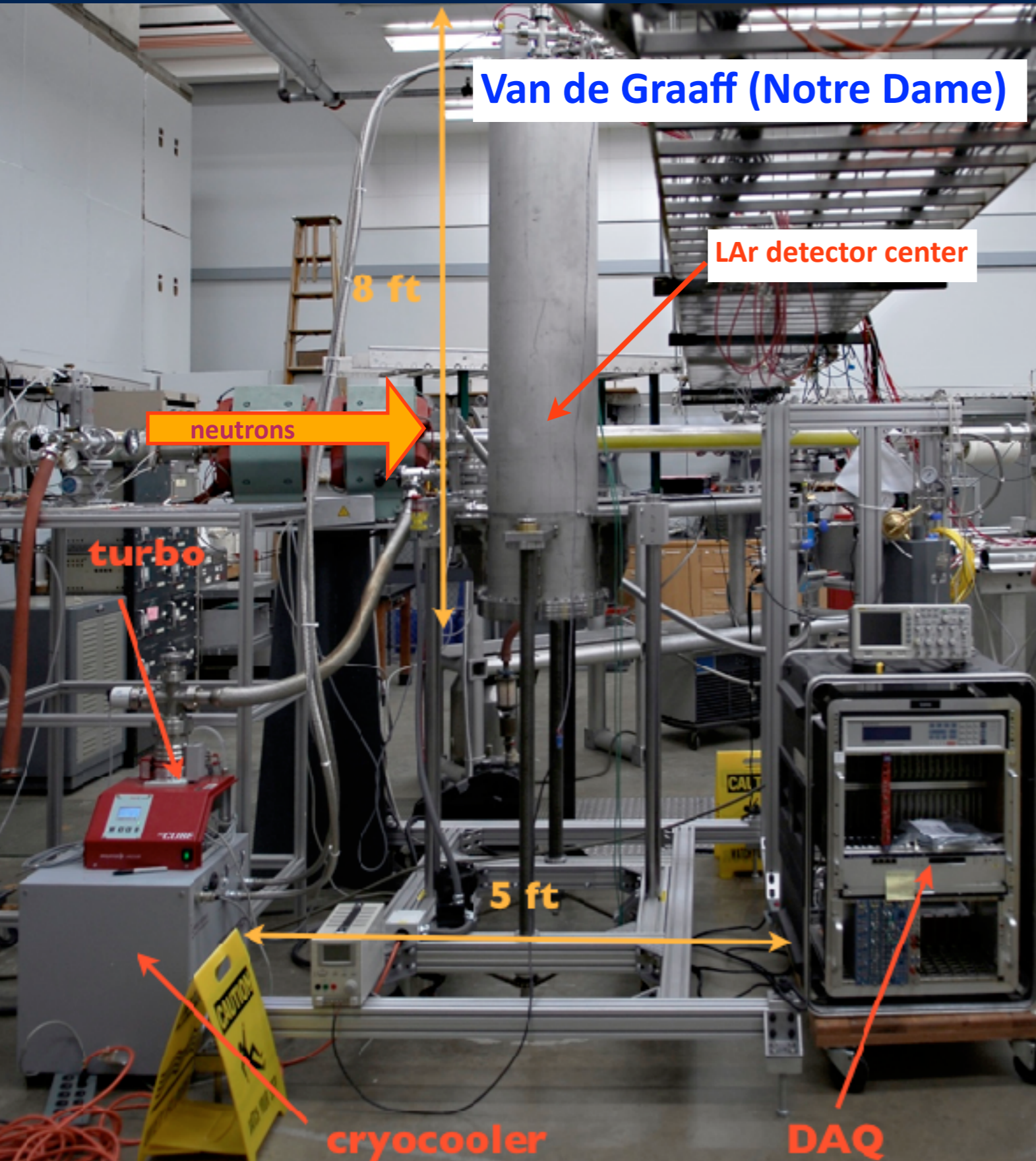

Neutron Beam Data (before cut)

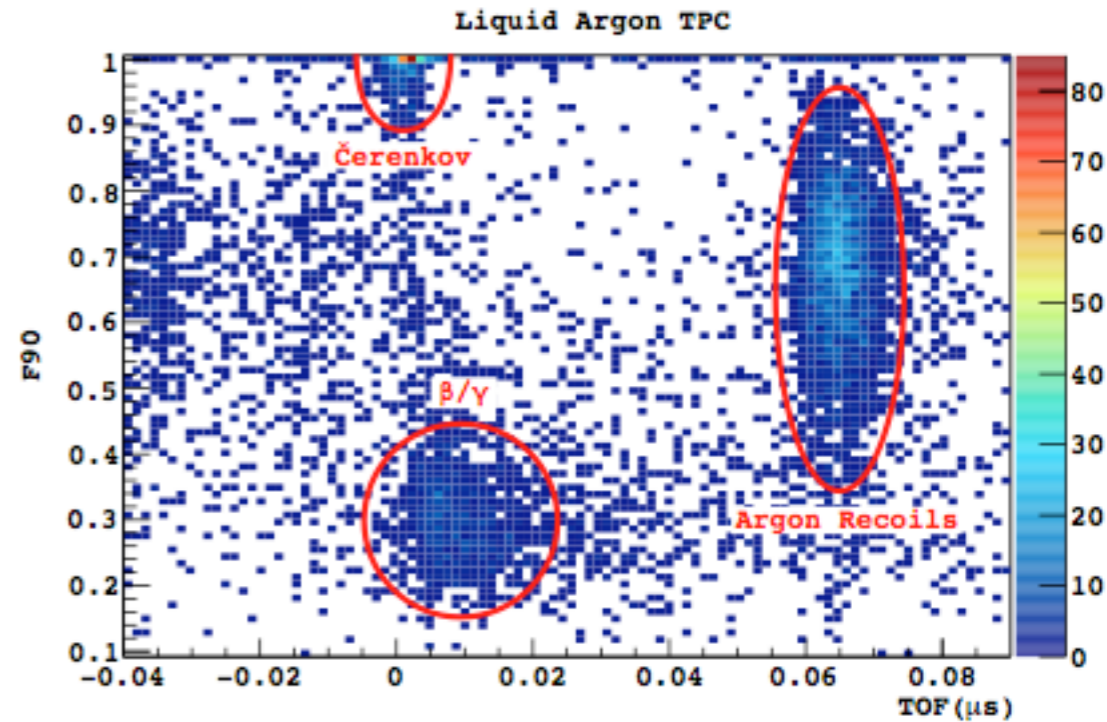

Neutron Beam Data (after cut)

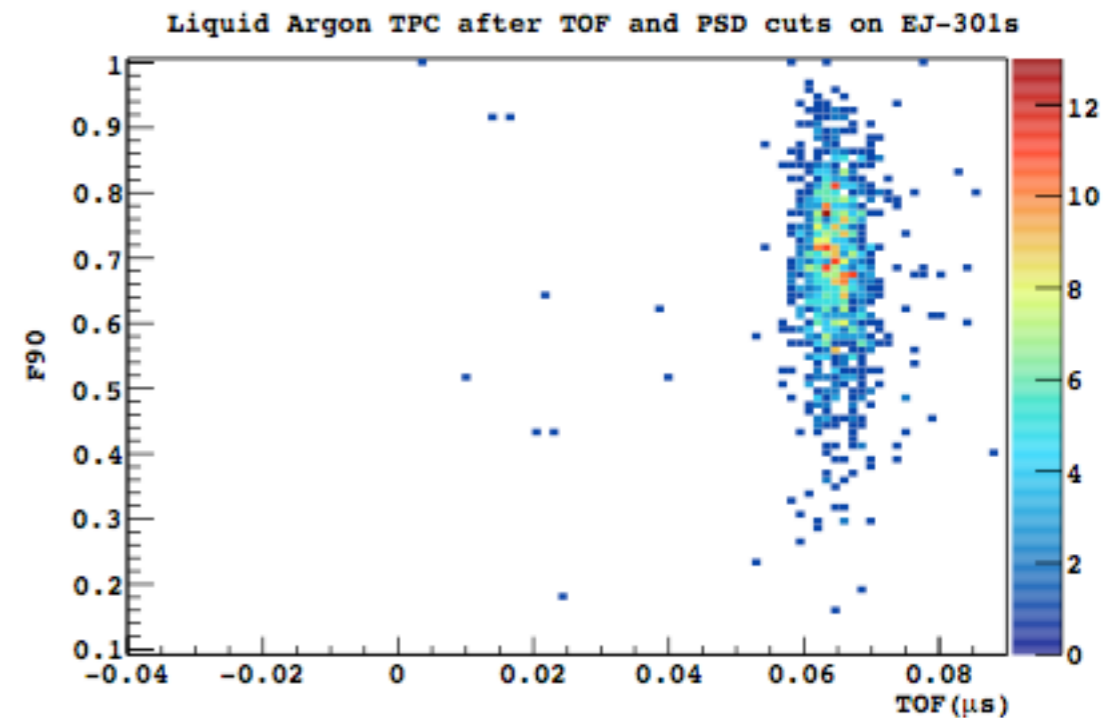

CENNS-10 Detector

CENNS-10 Single-phase LAr Detector

- Designed, developed, and led by J.Yoo at Fermilab 2012
- Single-phase detector: Pulse shape discrimination

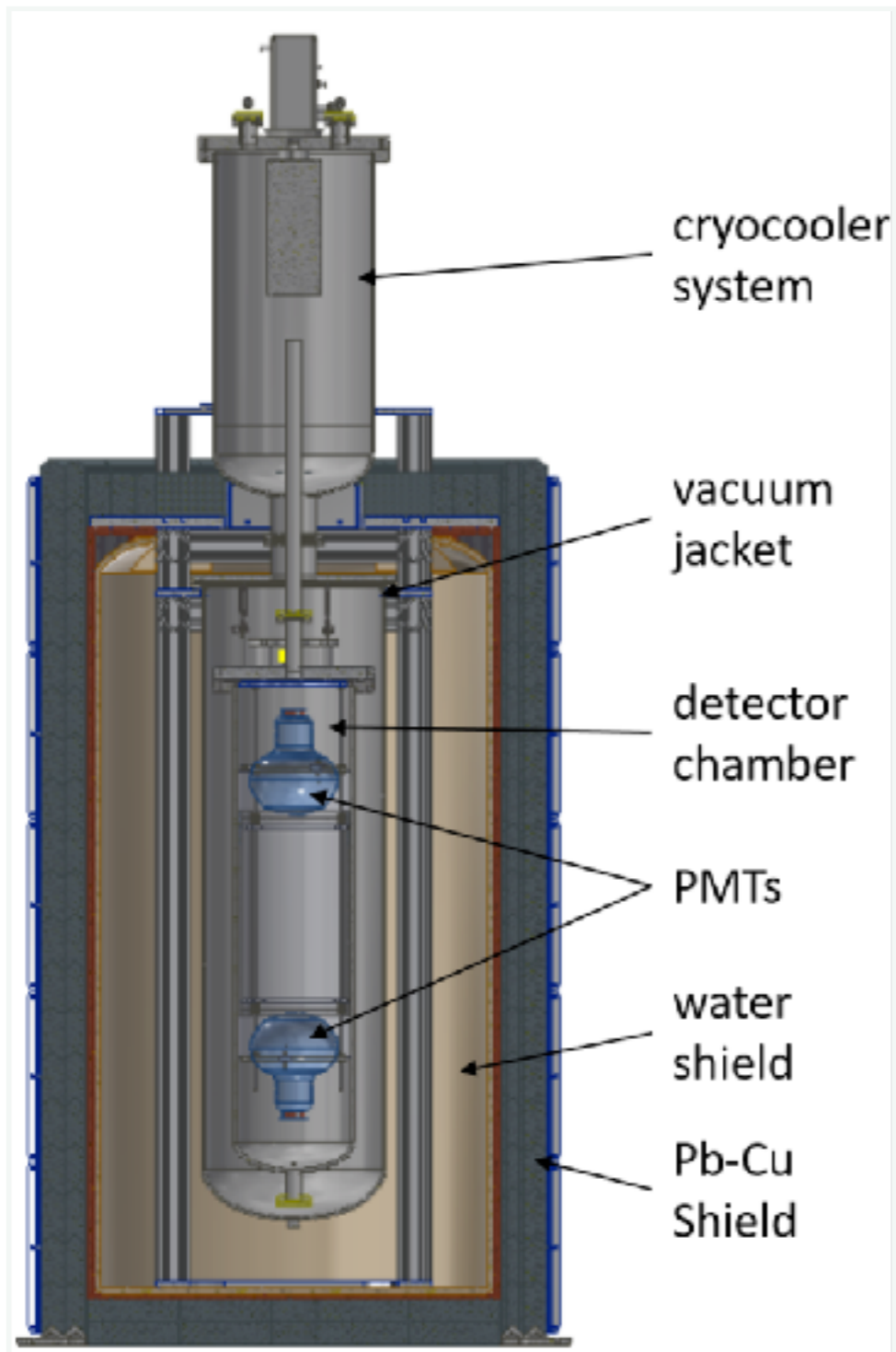

CENNS-10 Detector

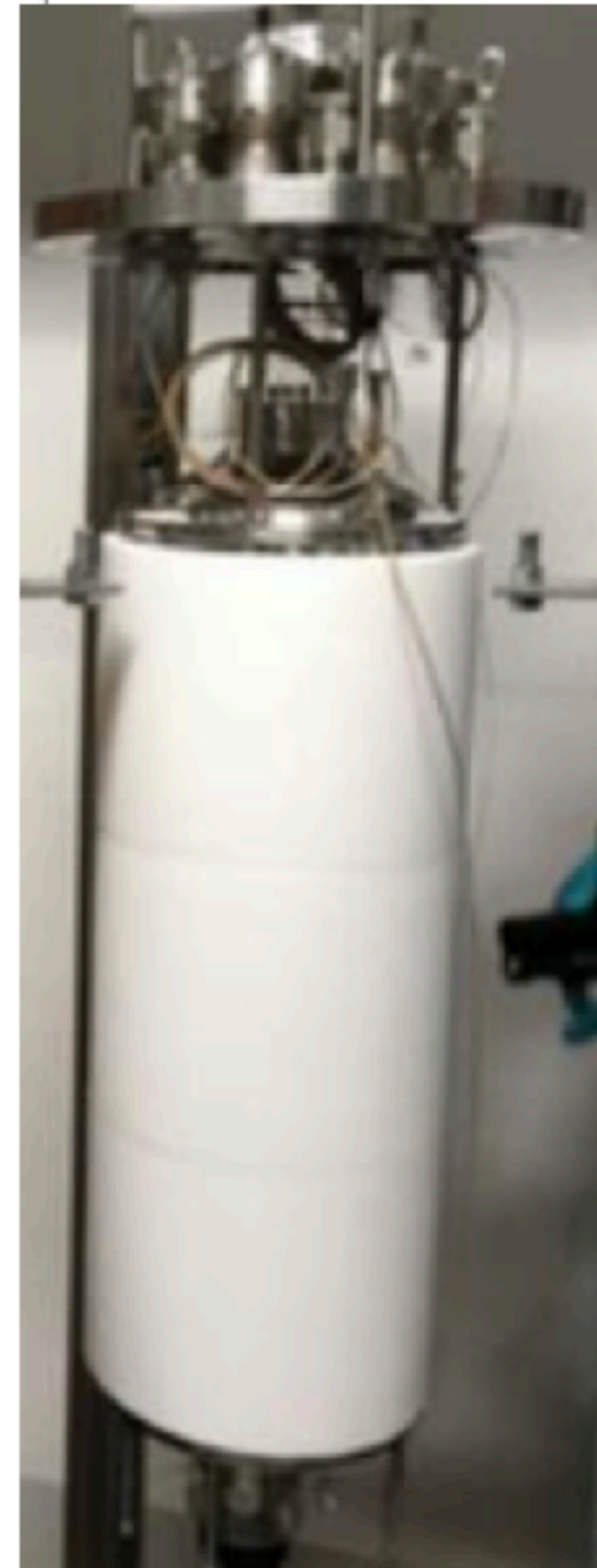
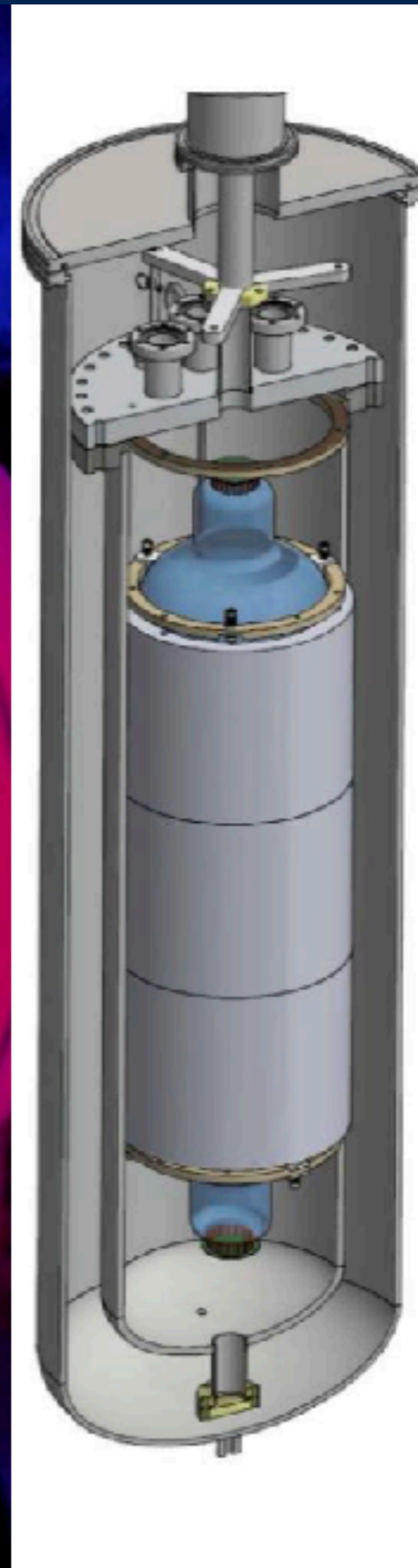

ORNL SNS

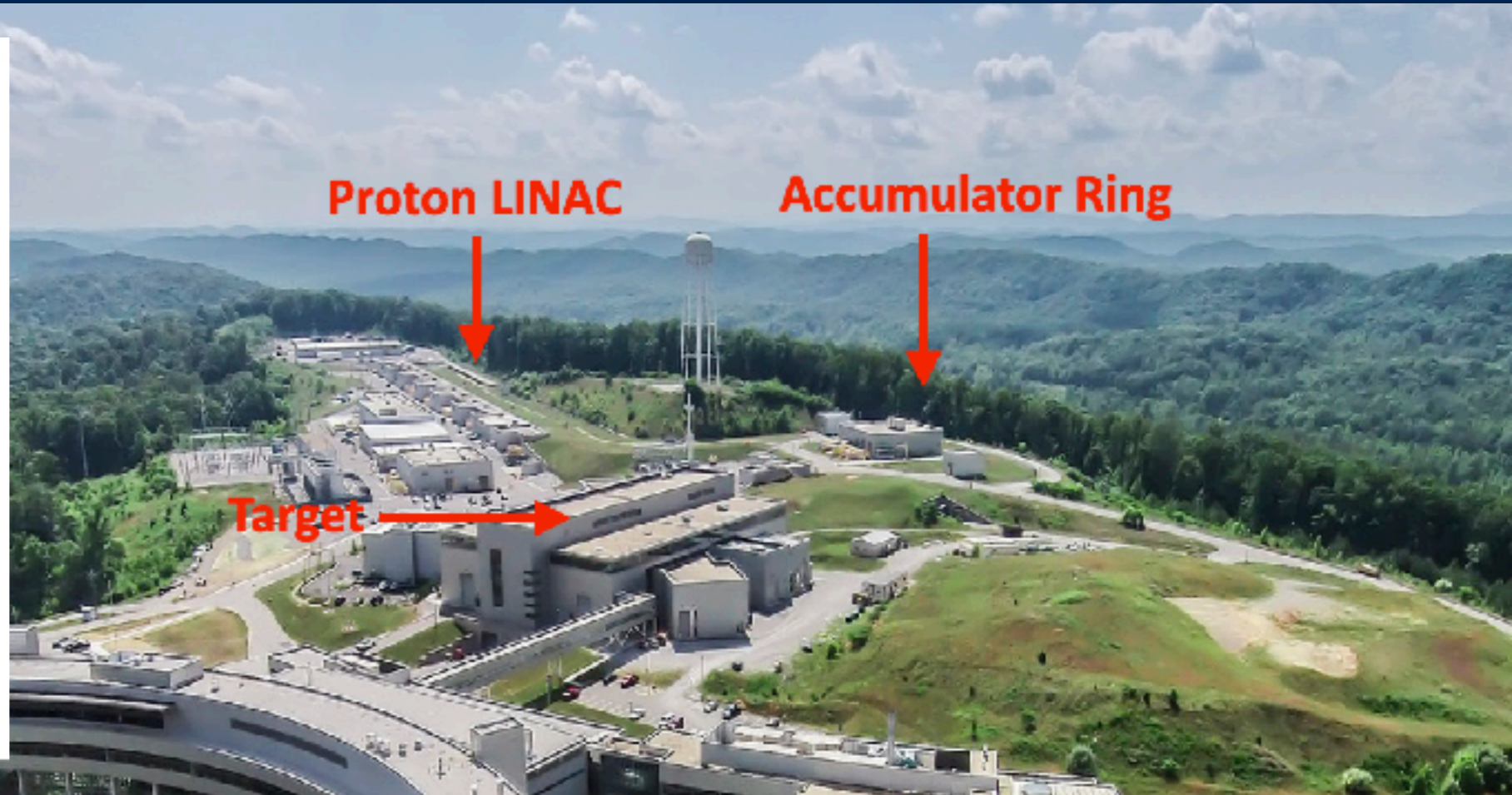
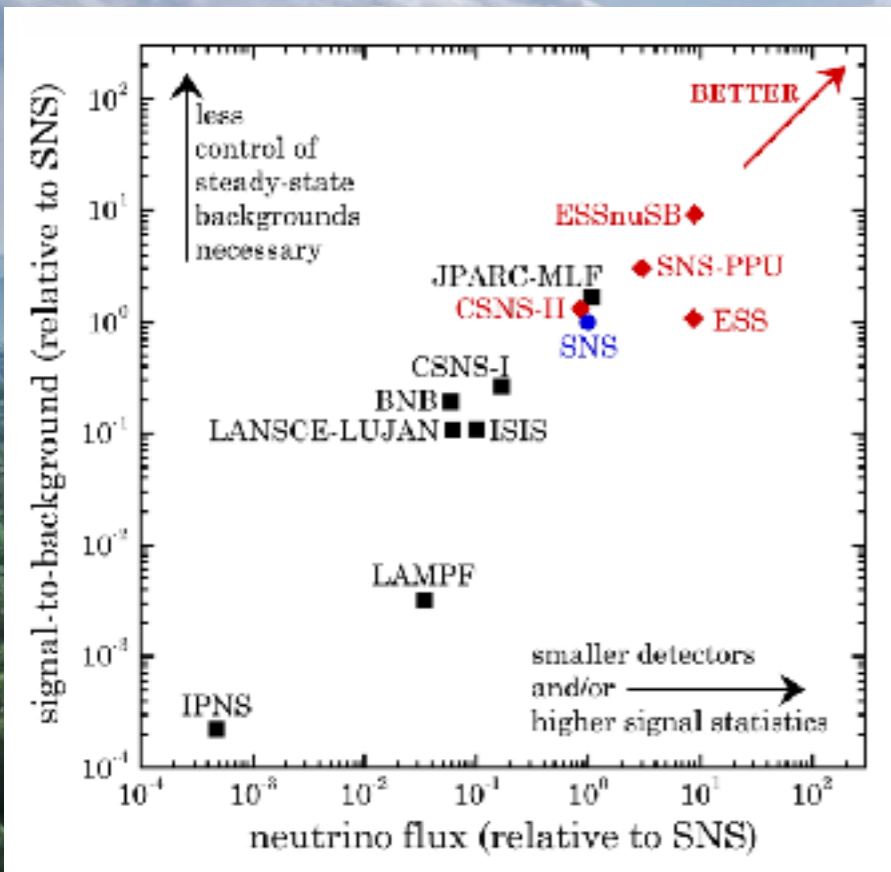

Spallation Neutron Source at ORNL

- Proton beam energy: 0.9-1.3 GeV
- Total power: ~ 1.4 MW
- Pulse duration: 380 ns
- Repetition rate: 60 Hz
- ν Flux $\sim 10^7/s/cm^2$ at 20m from the target
- Steady state background rejection factor $\sim 10^{-4}$

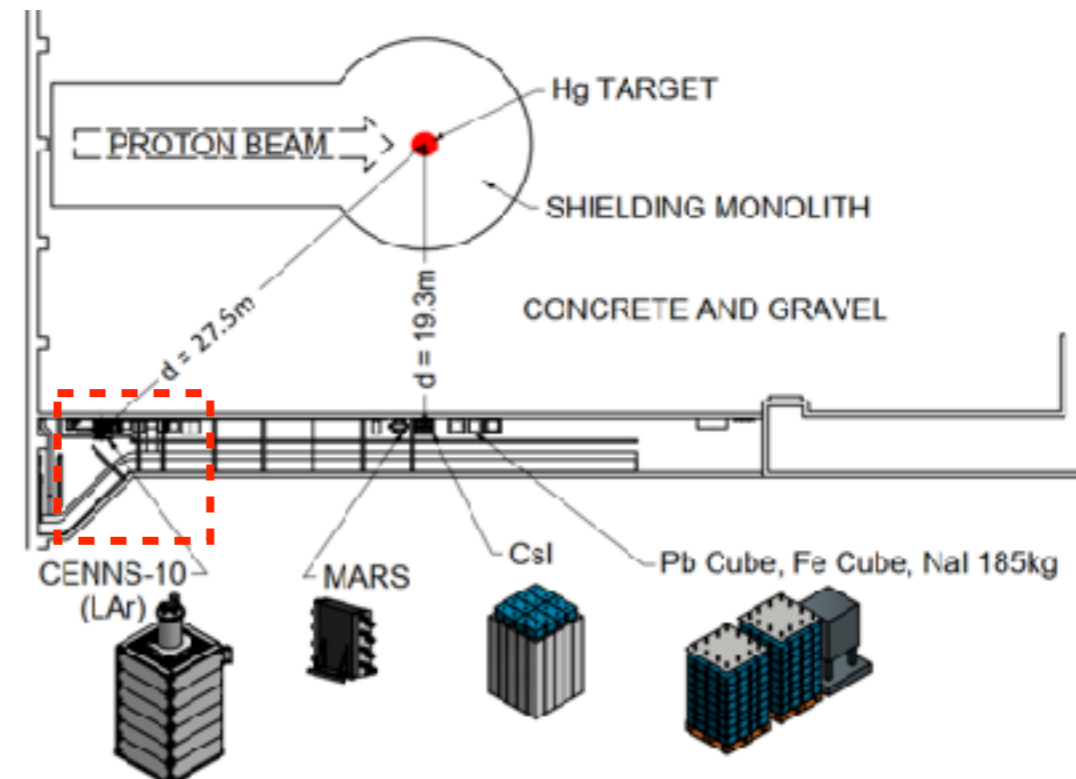

SNS Neutrinos

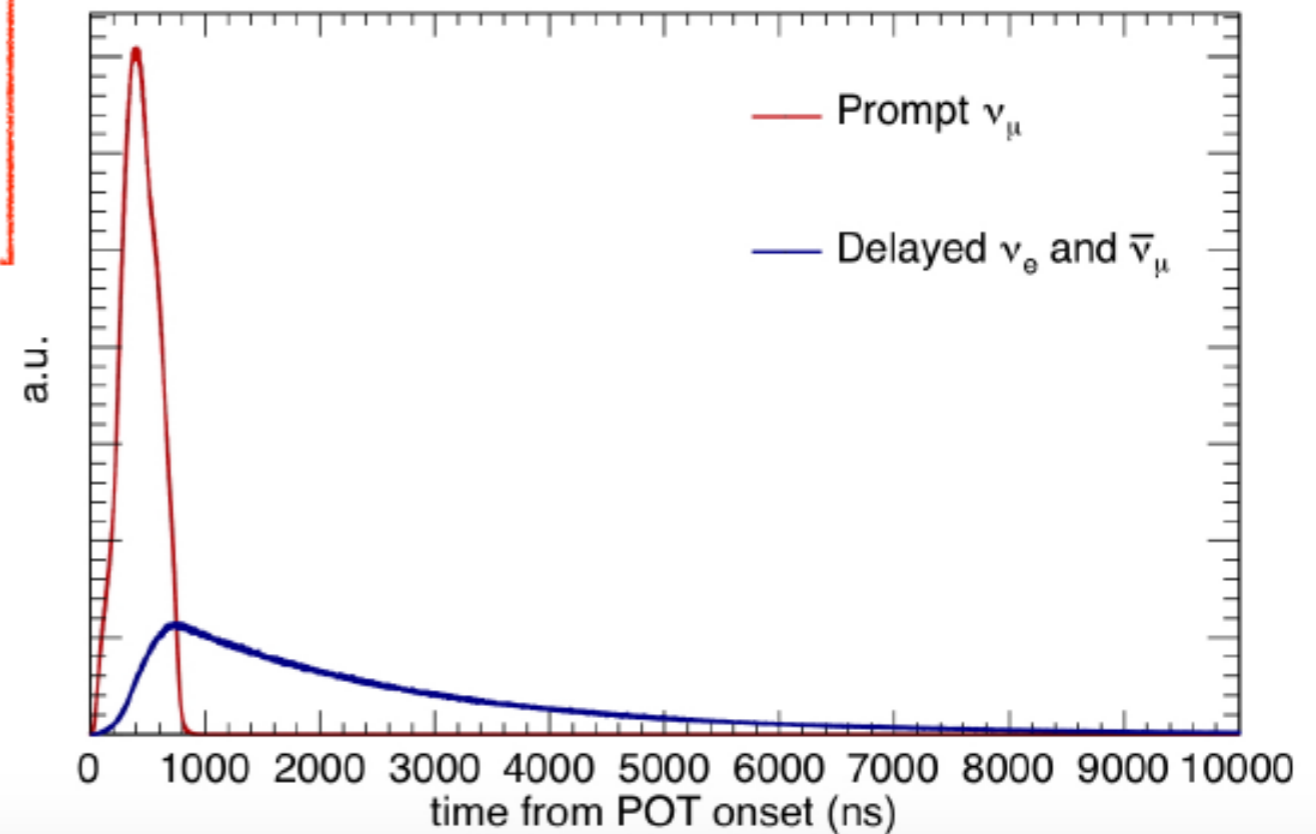
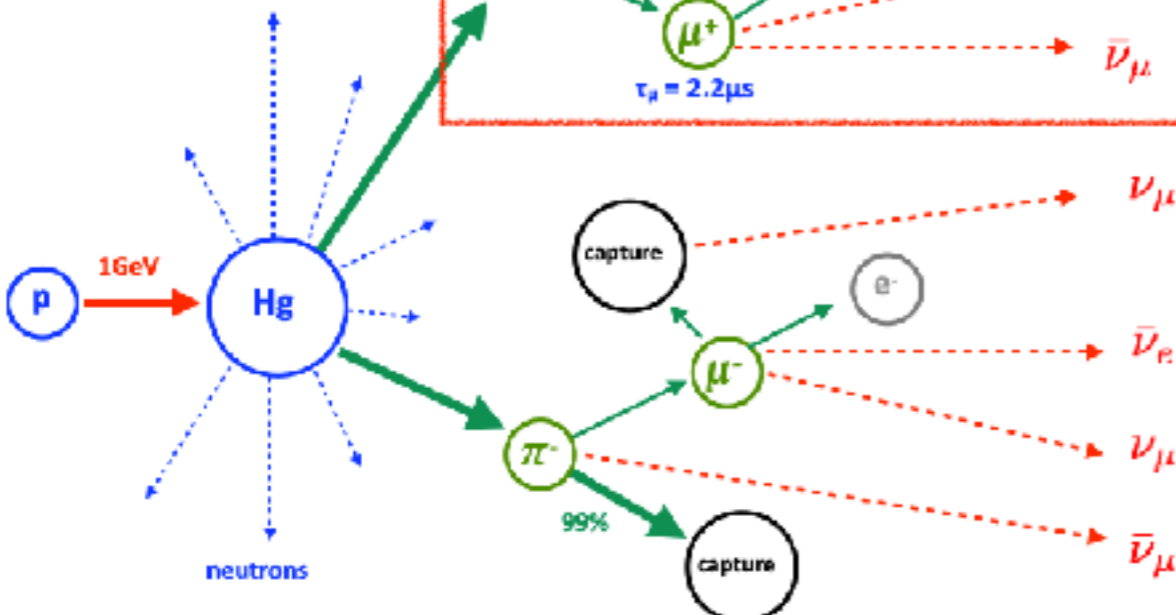
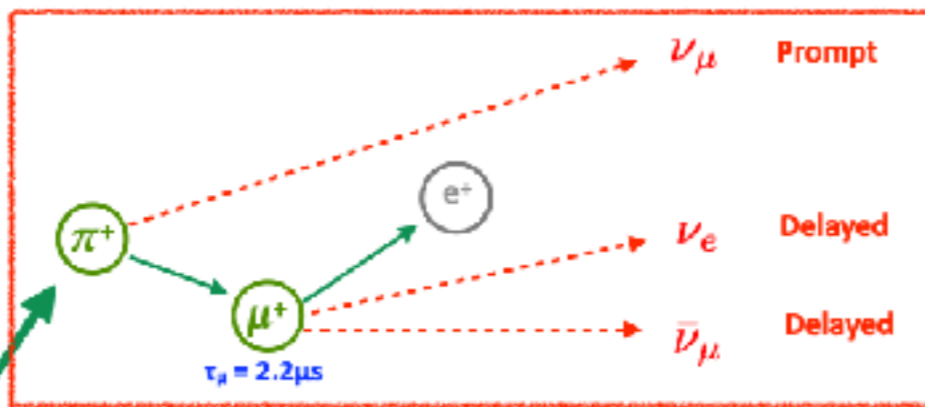
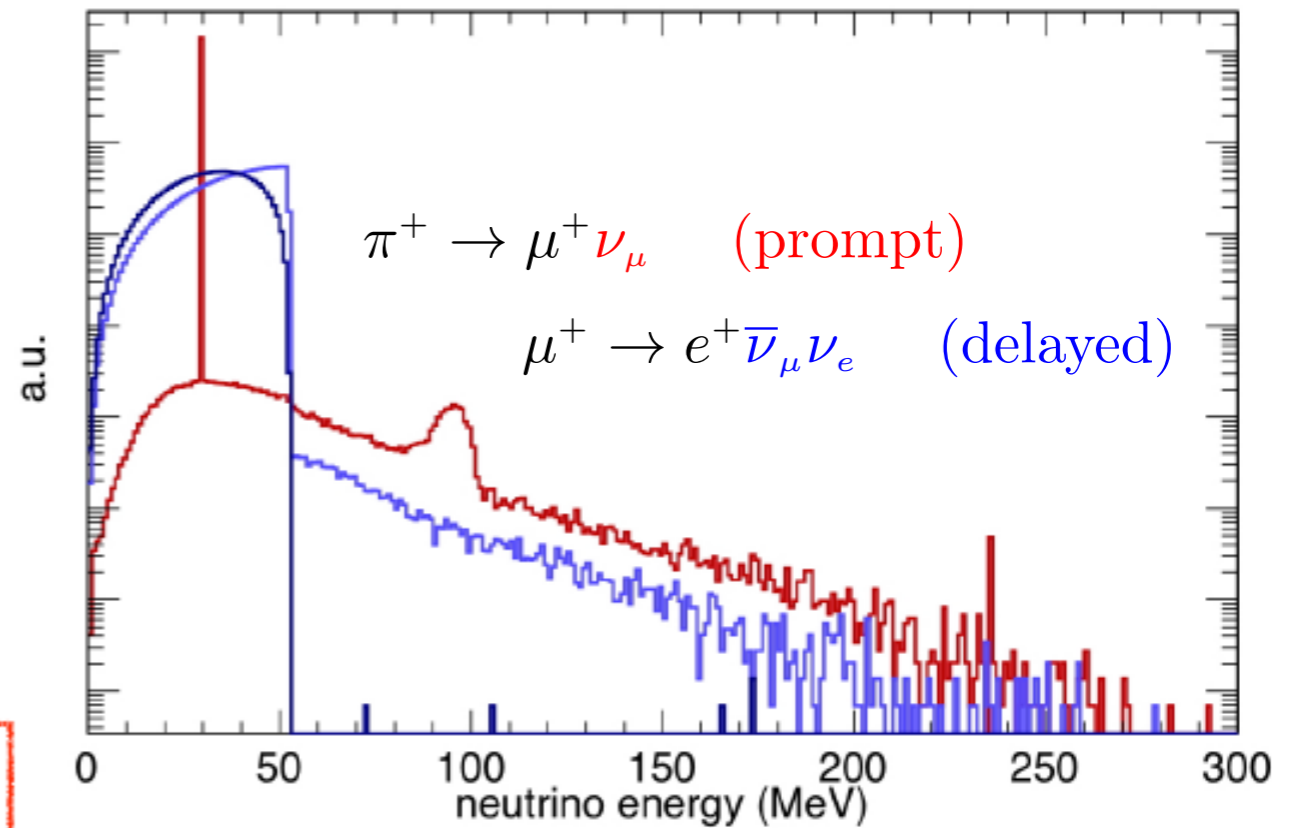
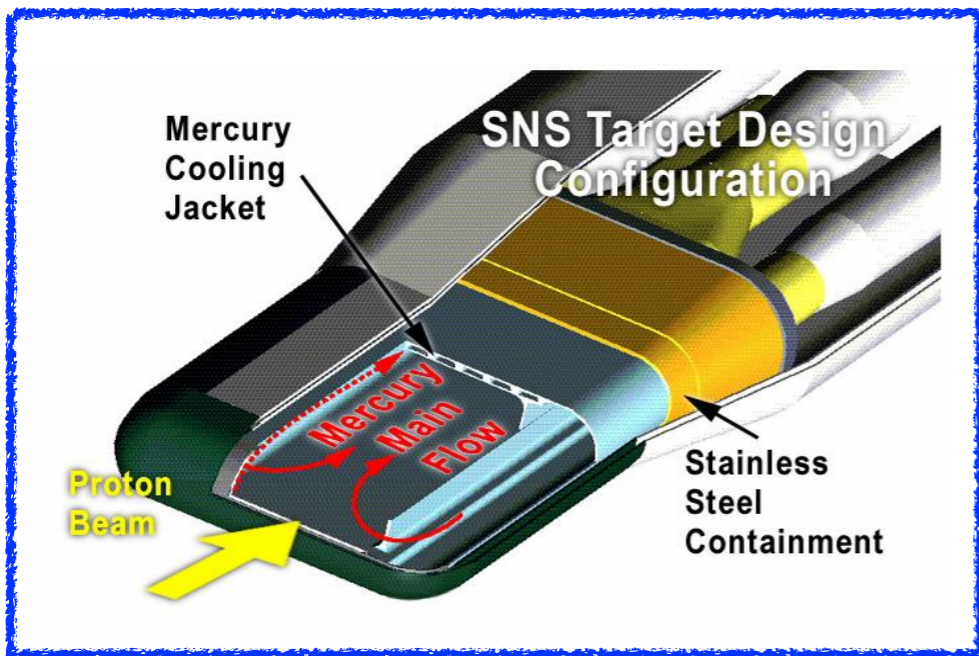

Neutron BG at SNS

SciBath neutron detector
Indiana University — R. Taylor

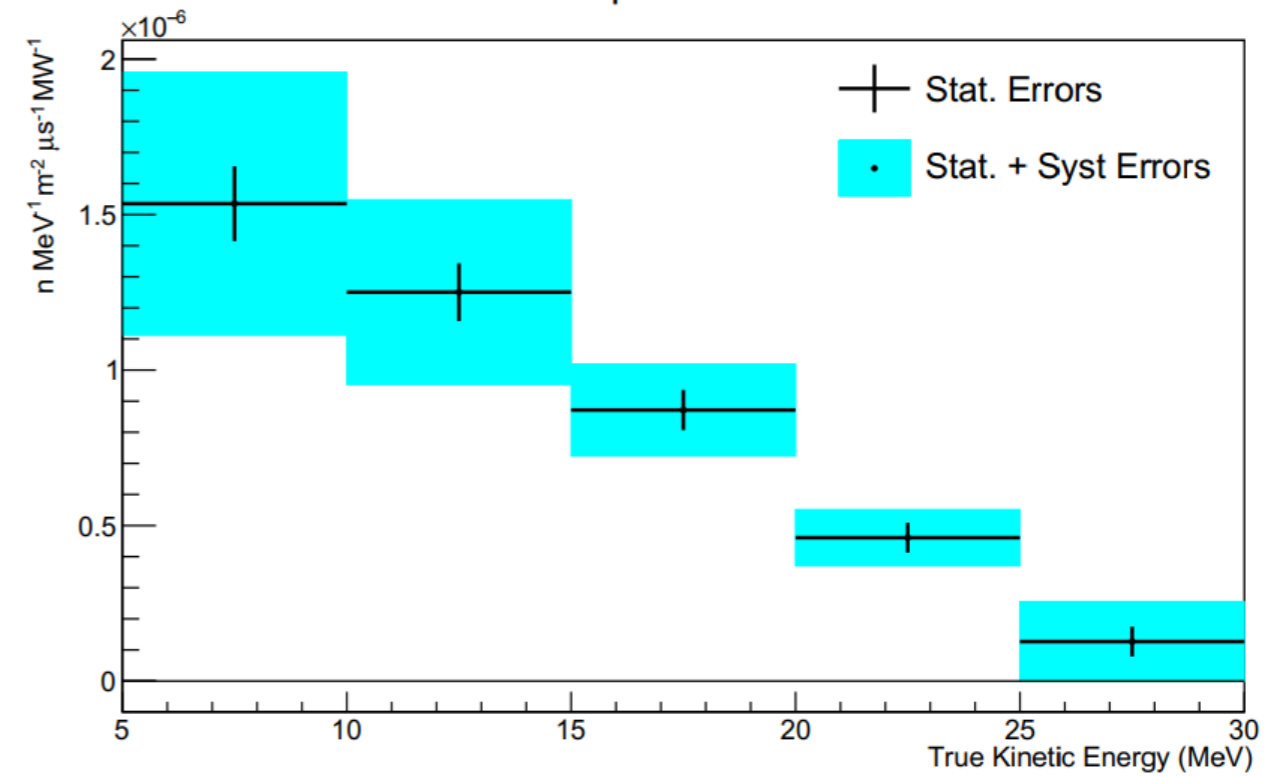
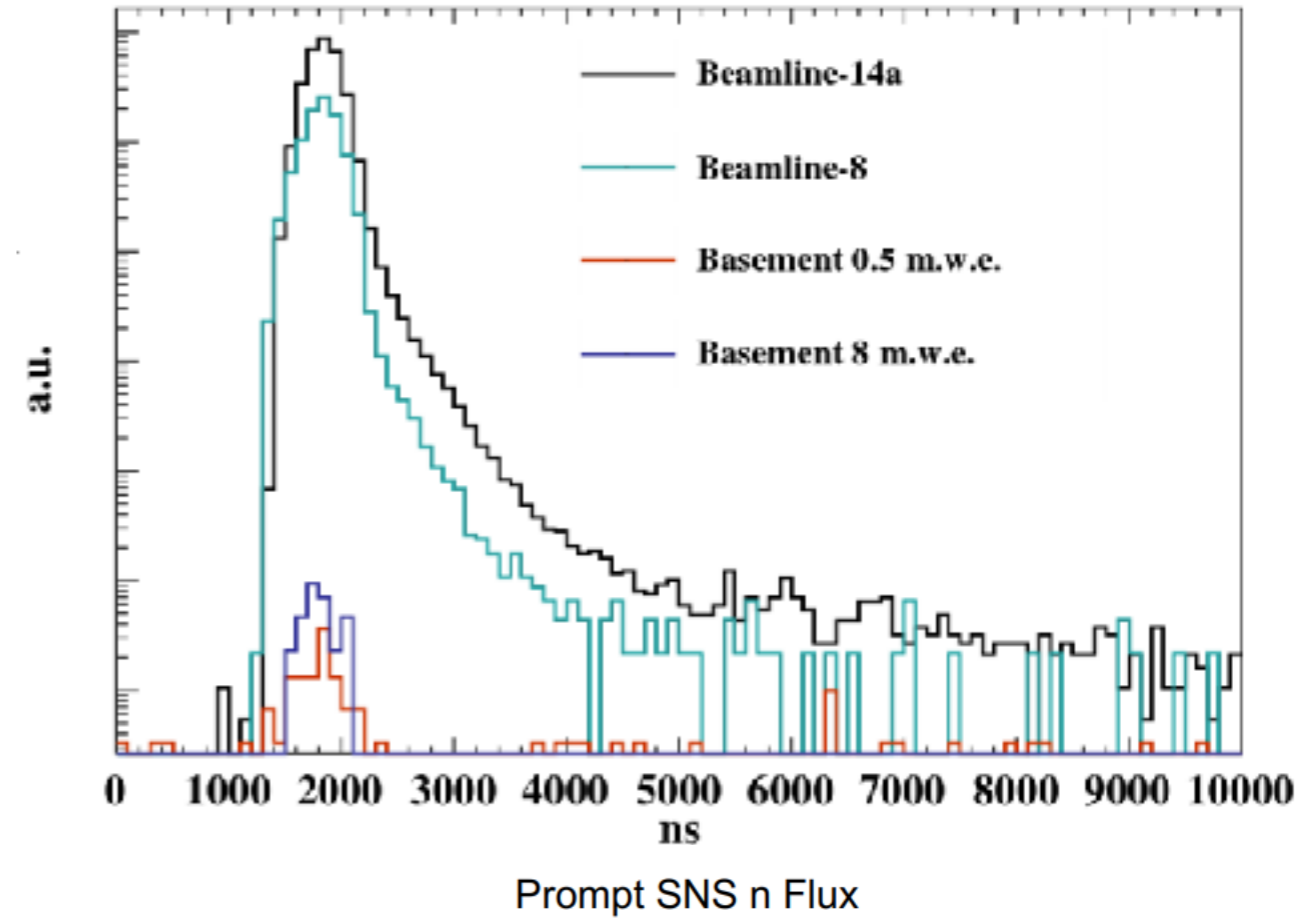
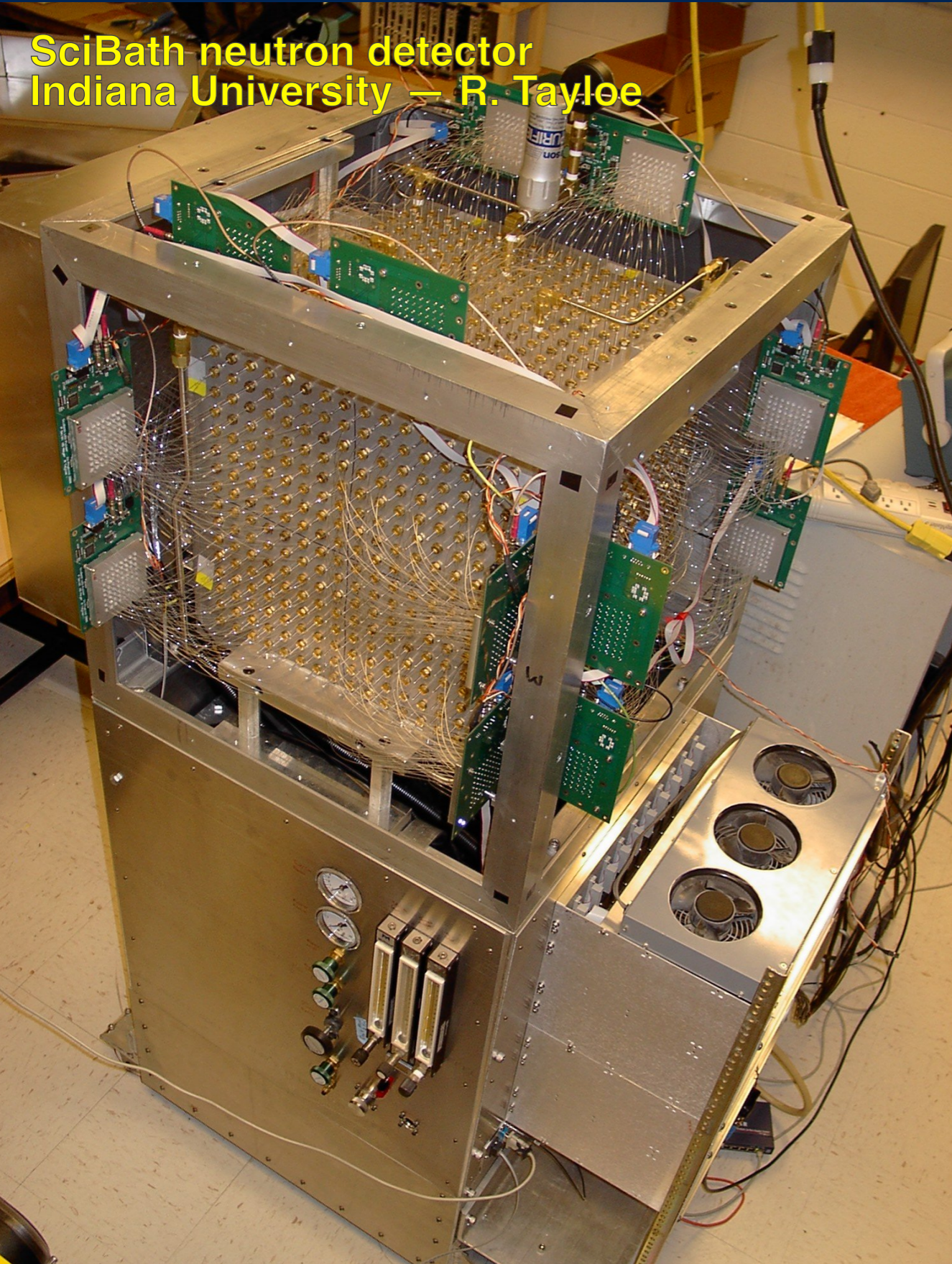

First Observation of CEvNS (2017)

- The first observation of CEvNS at a 6.7σ confidence level (**Csl target**)
- Best fit of data: 134 ± 22 CEvNS events (SM prediction: 173 ± 48 events)
- **Smallest neutrino detector ever (14.6kg)!**
- Updated CEvNS measurement in 2022: **11σ observation**

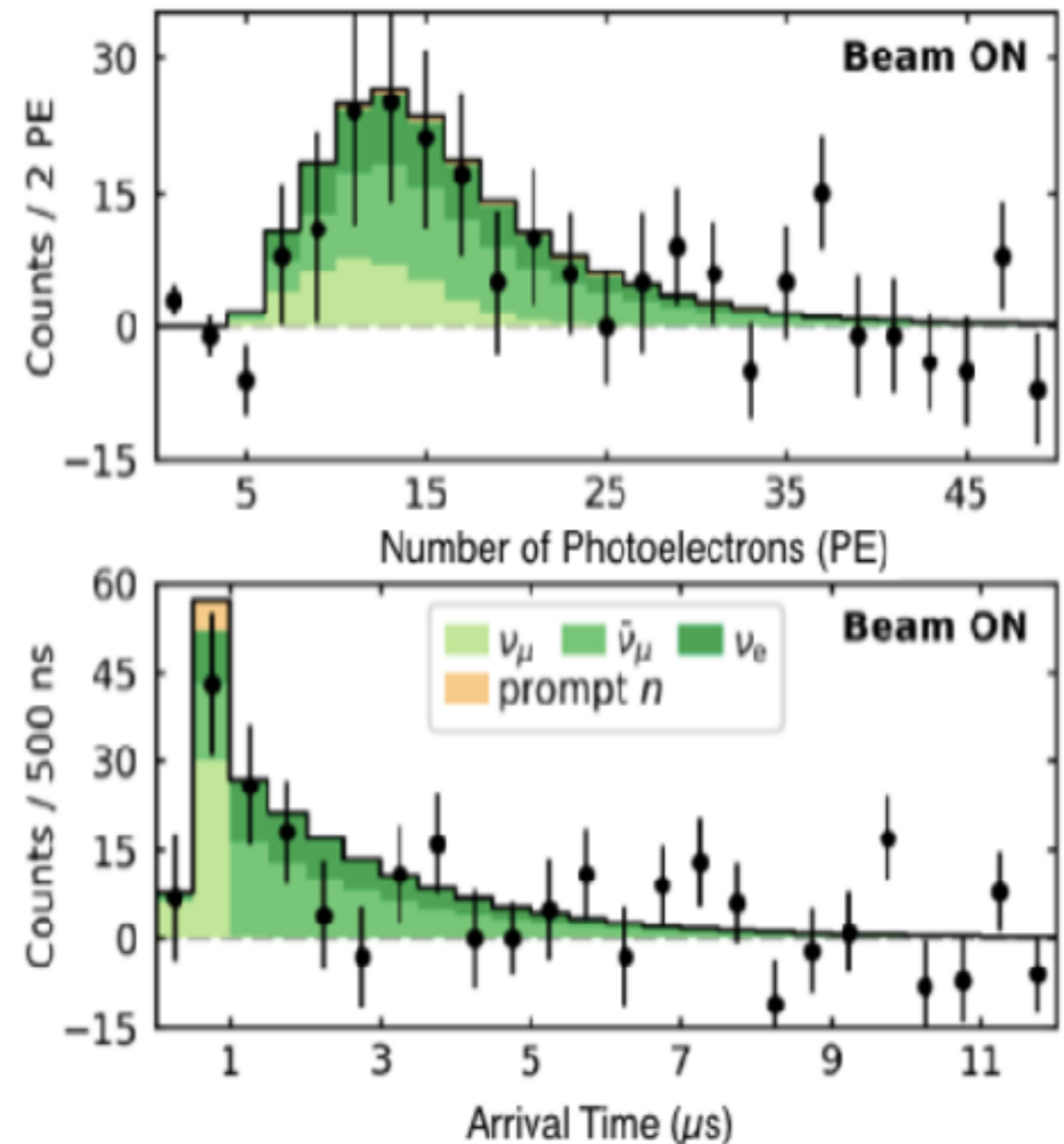

ORNL Neutrino Alley

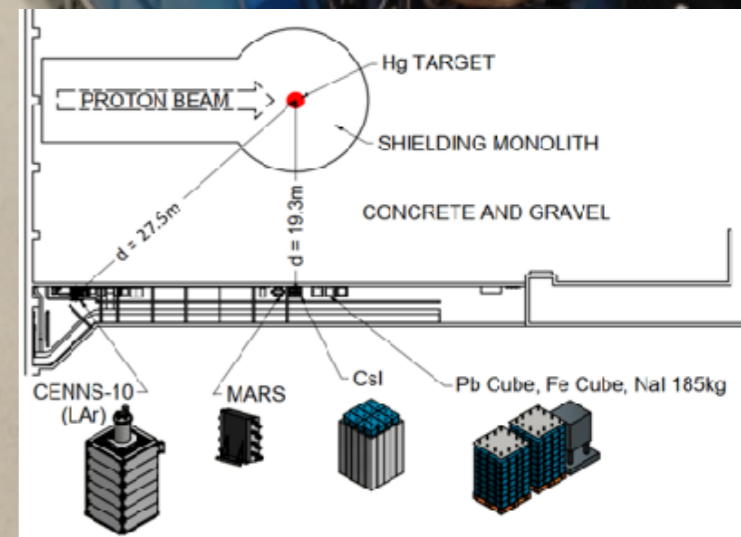

CENNS-10 Calibration

JINST 16 P04002 (2021)

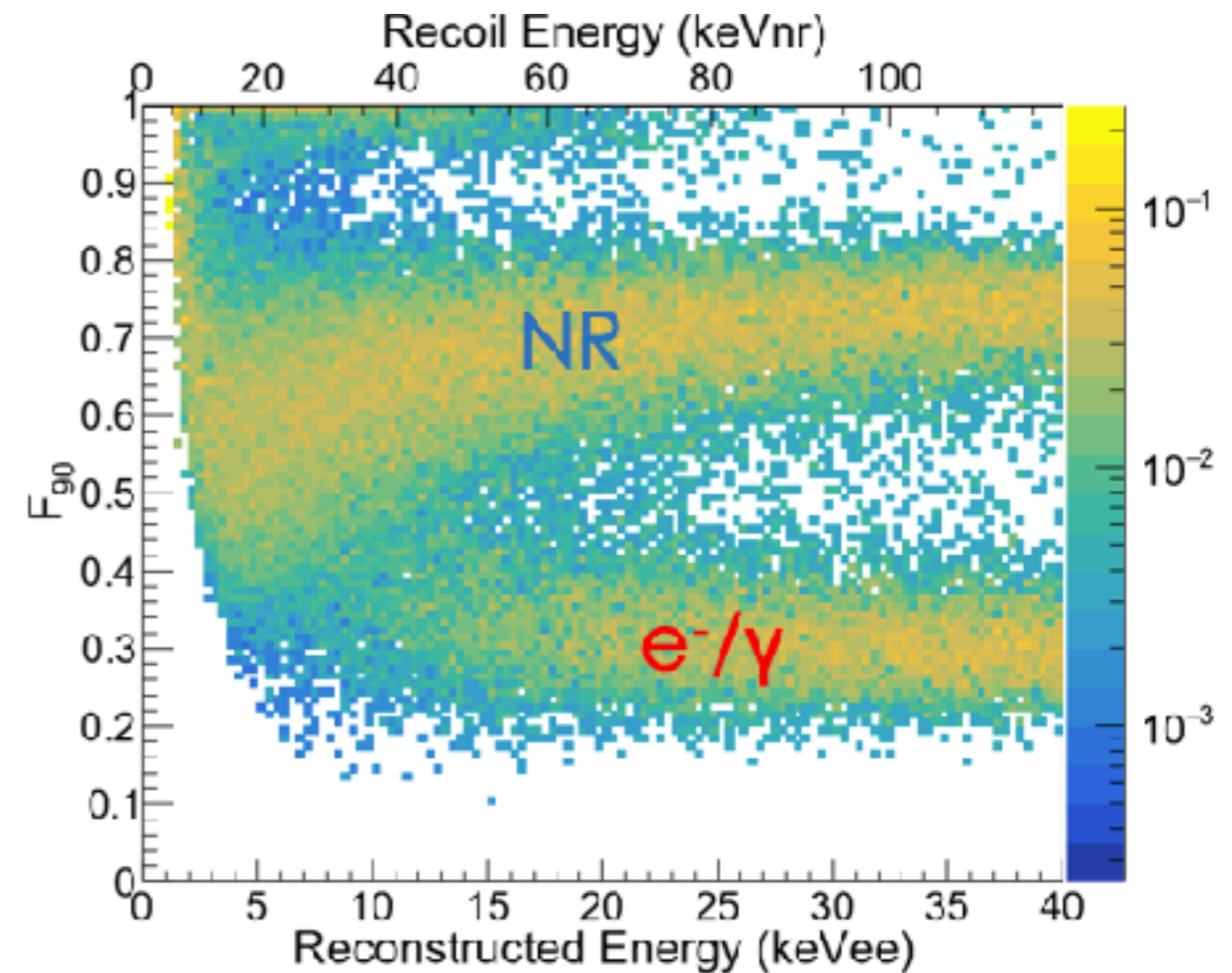
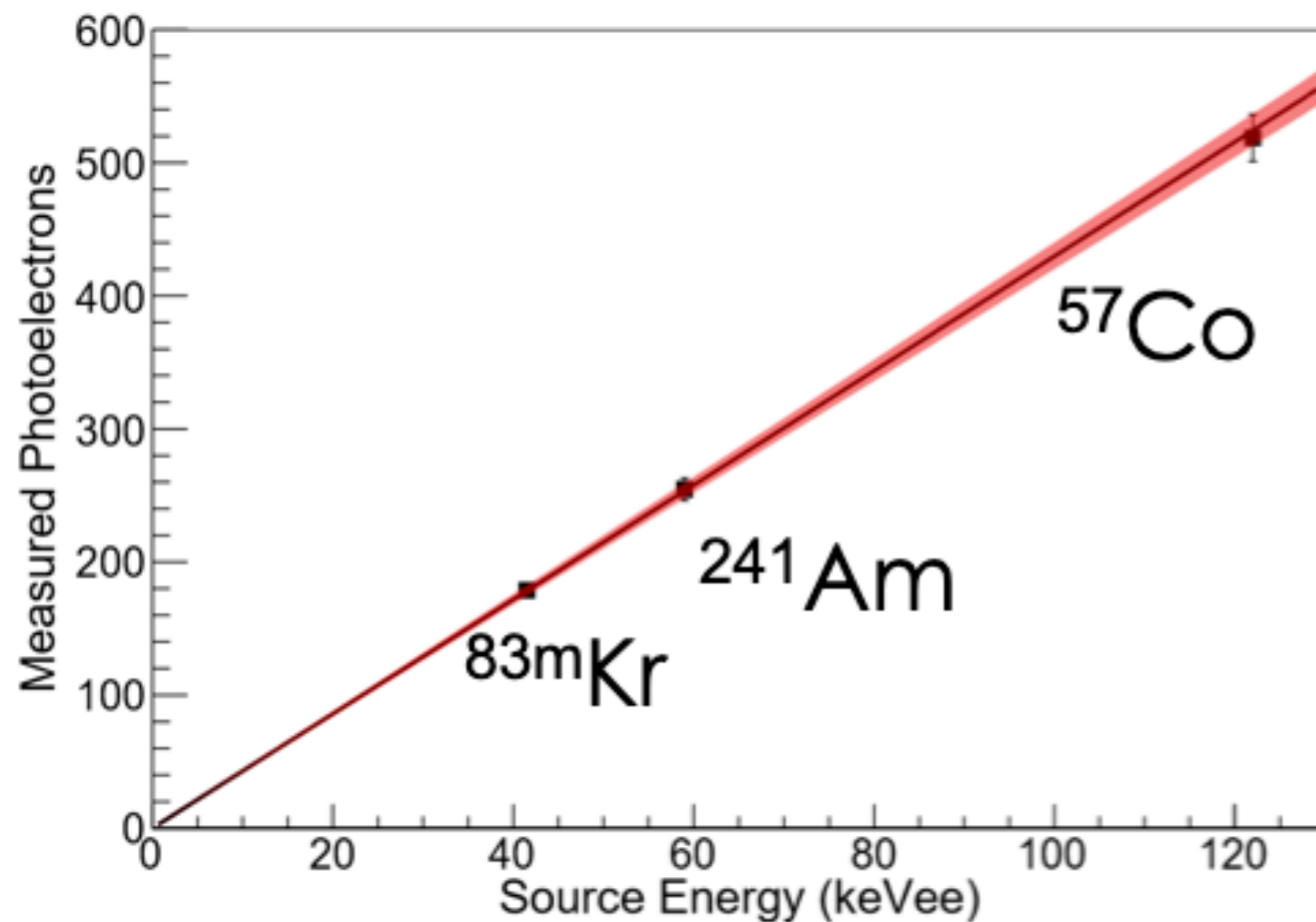
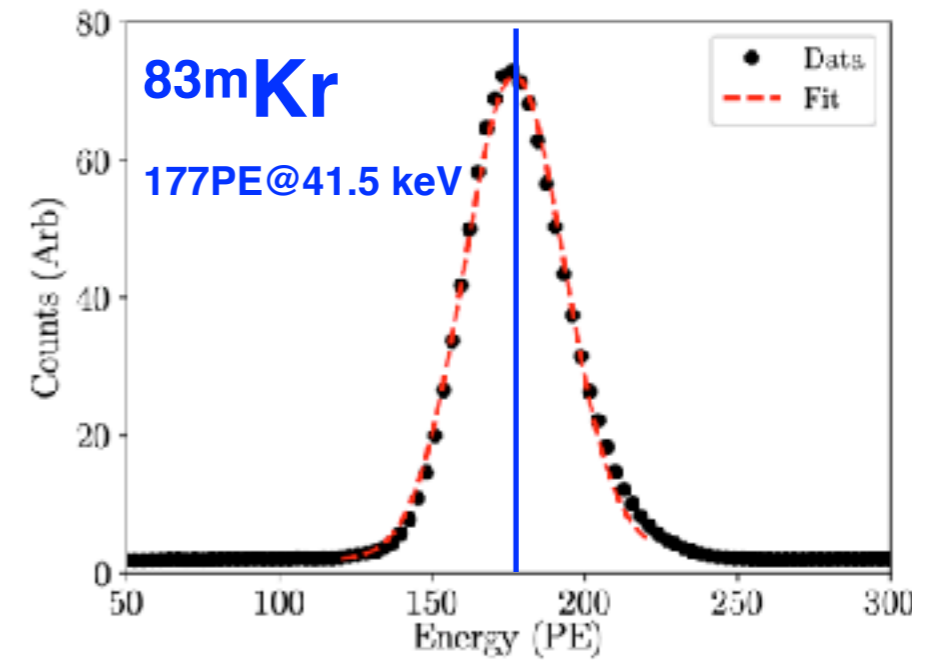
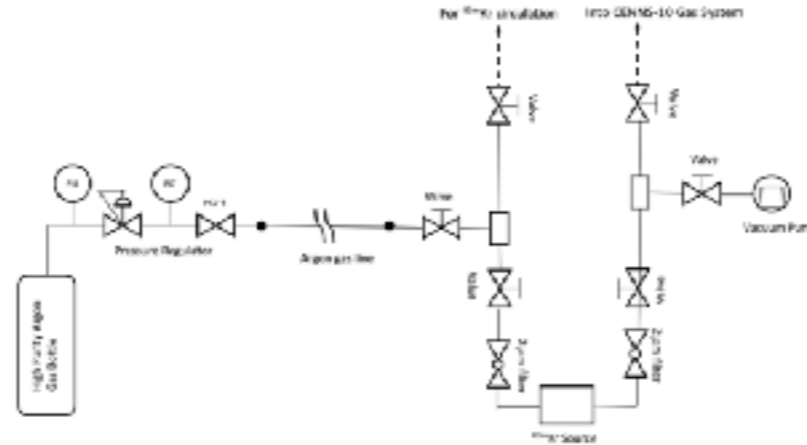
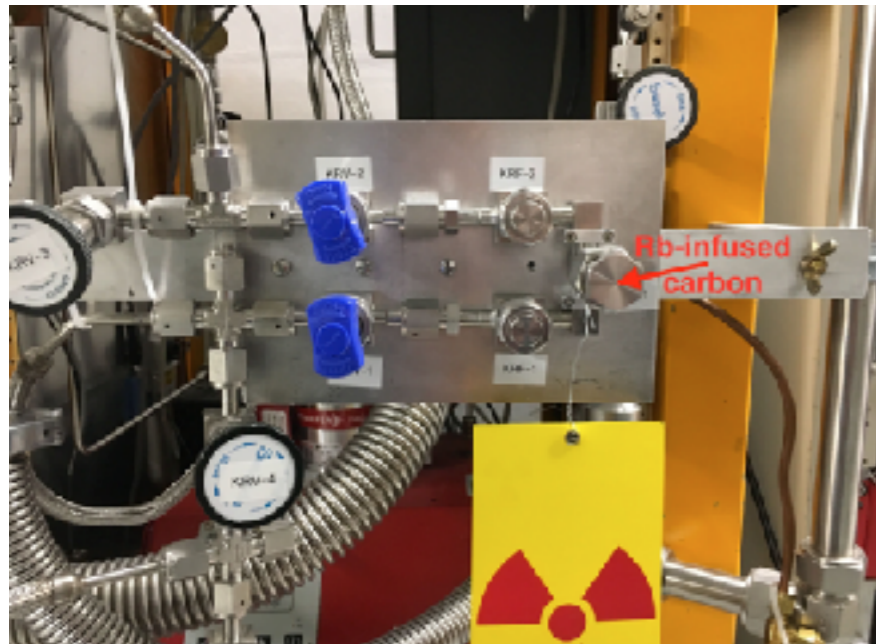

CENNS-10: Neutrons

- Beam-related neutron (BRN) is the most serious background of this measurement
- BRN is normalized using no-water shielding data
(Removed 20 cm water shielding by emptying the water tank of the CENNS-10)
- 0.54 GWhr (3 weeks) integrated beam power of [no-water shielding data](#)
- Predicted flux input to MC comes from external flux measurement at CENNS-10

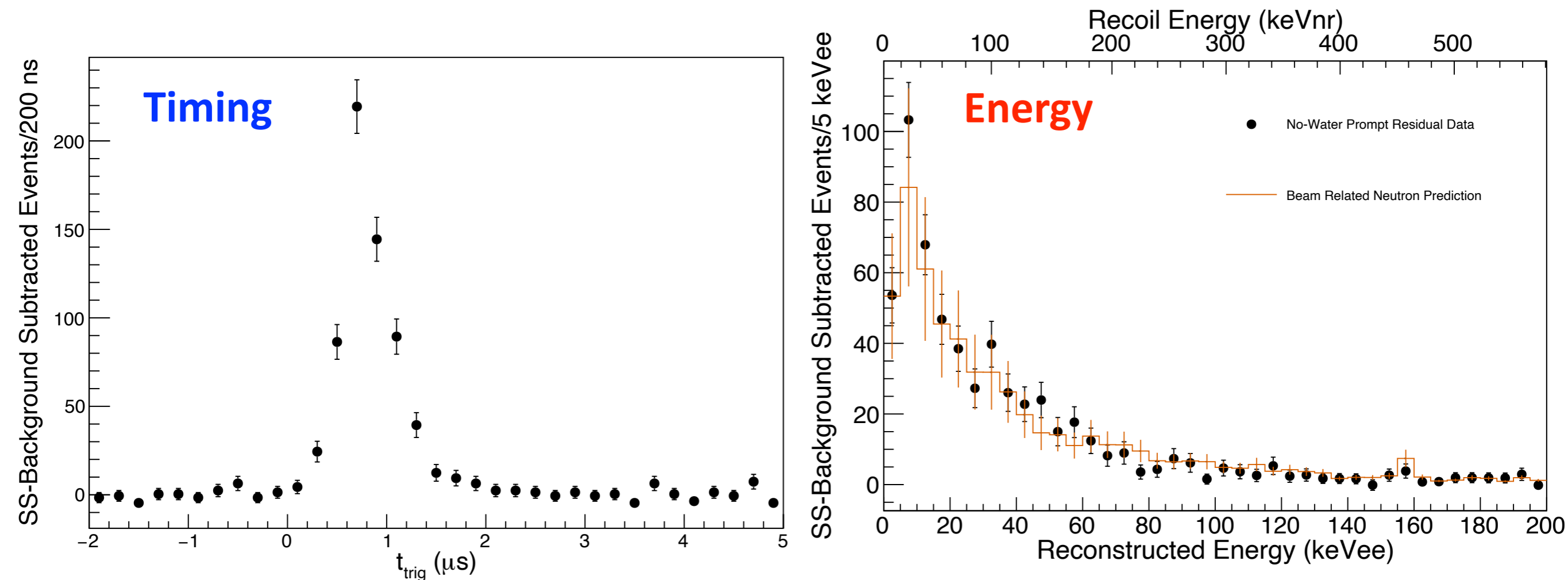

CENNS-10: Efficiency & Light Yield

SNS trigger

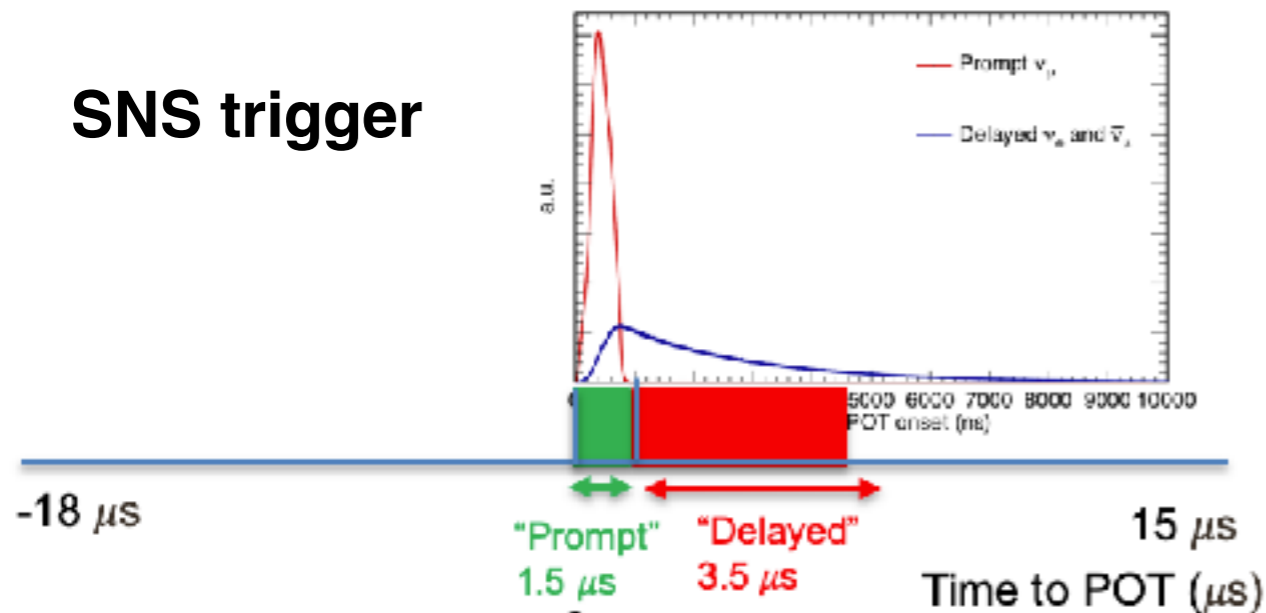

- Two groups performed independent analysis
 - No cut-values are shared between two groups
 - A:** Allow more CEvNS candidates
 - B:** Reduce background as much as possible
- Blind Analysis
 - Beam-on data were blind until cuts are finalized
- Baseline, Saturation, Pile-up > 96% of events pass
- Candidate events: Maximum likelihood
 - E_{th} (> 2 p.e. in both PMTs)

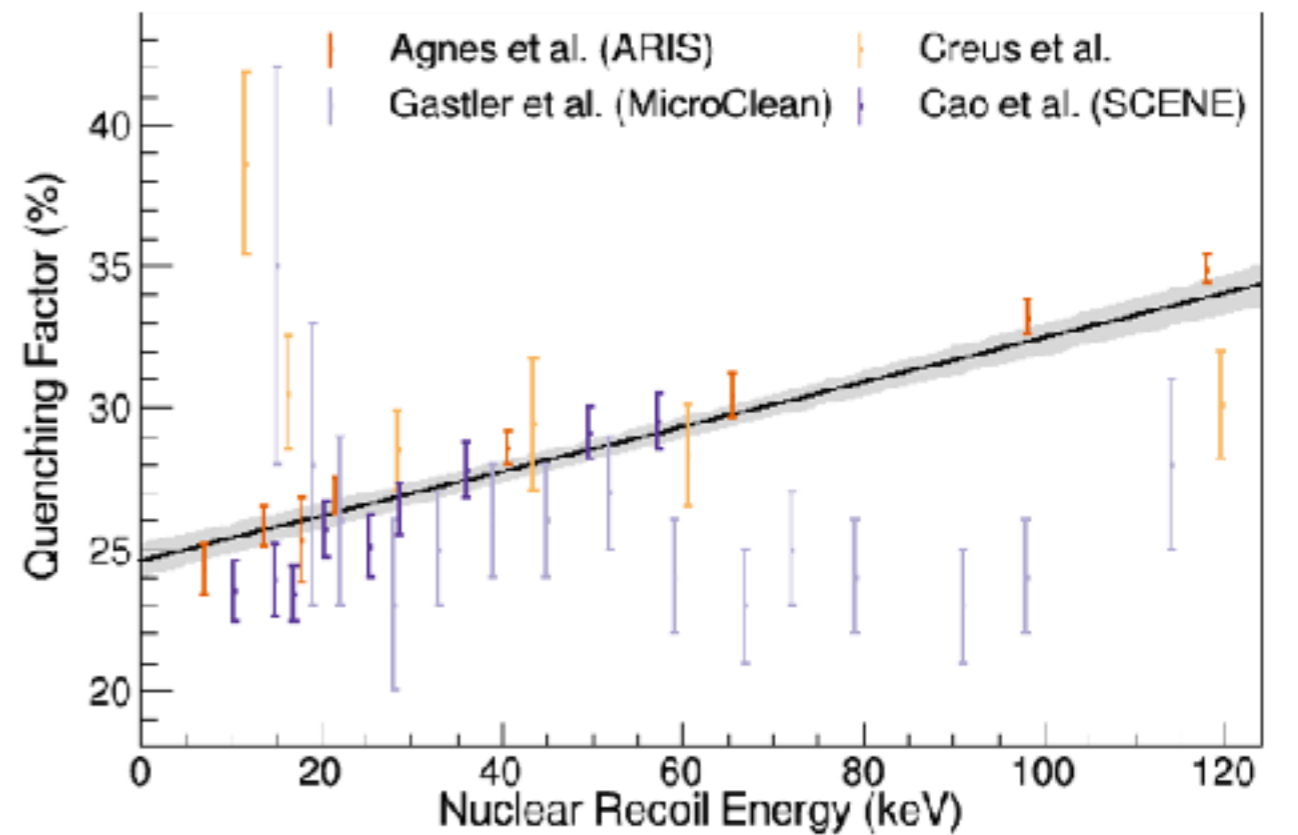
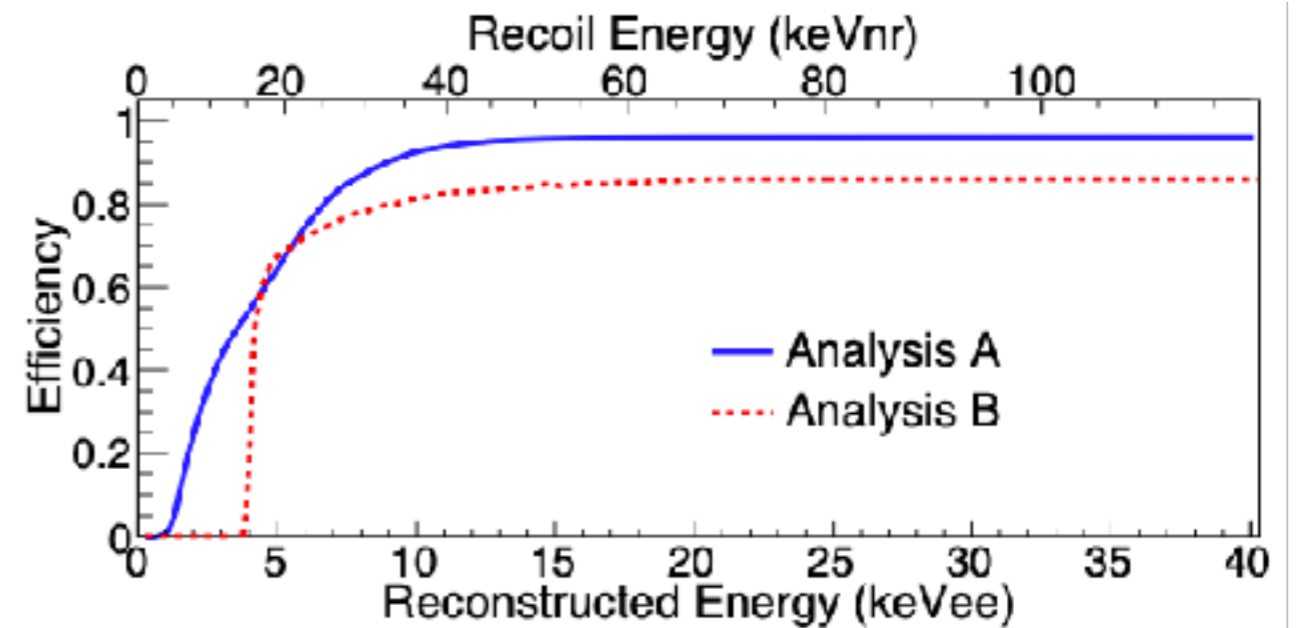

2% average relative uncertainty on light yield value in region of interest from 0-125 keV_{nr}

CENNS-10 Run-1 Result (2021)

- CEvNS measurement: 159 ± 43 events

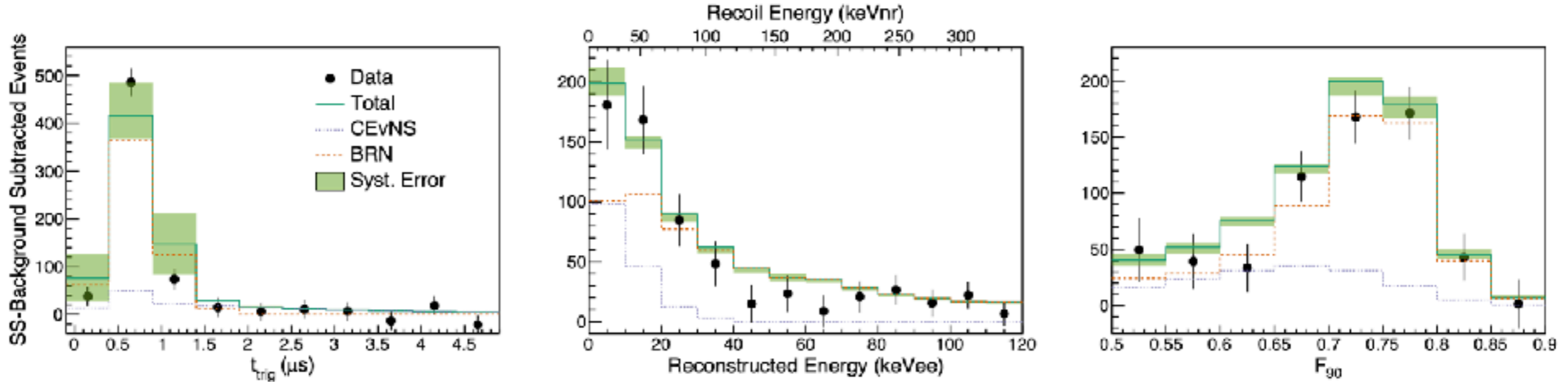

- CEvNS cross-section (Ar) : $\sim 30\%$ uncertainty

$$\sigma_{\nu\text{-Ar}} = (2.2 \pm 0.7) \times 10^{-39} \text{ cm}^2$$

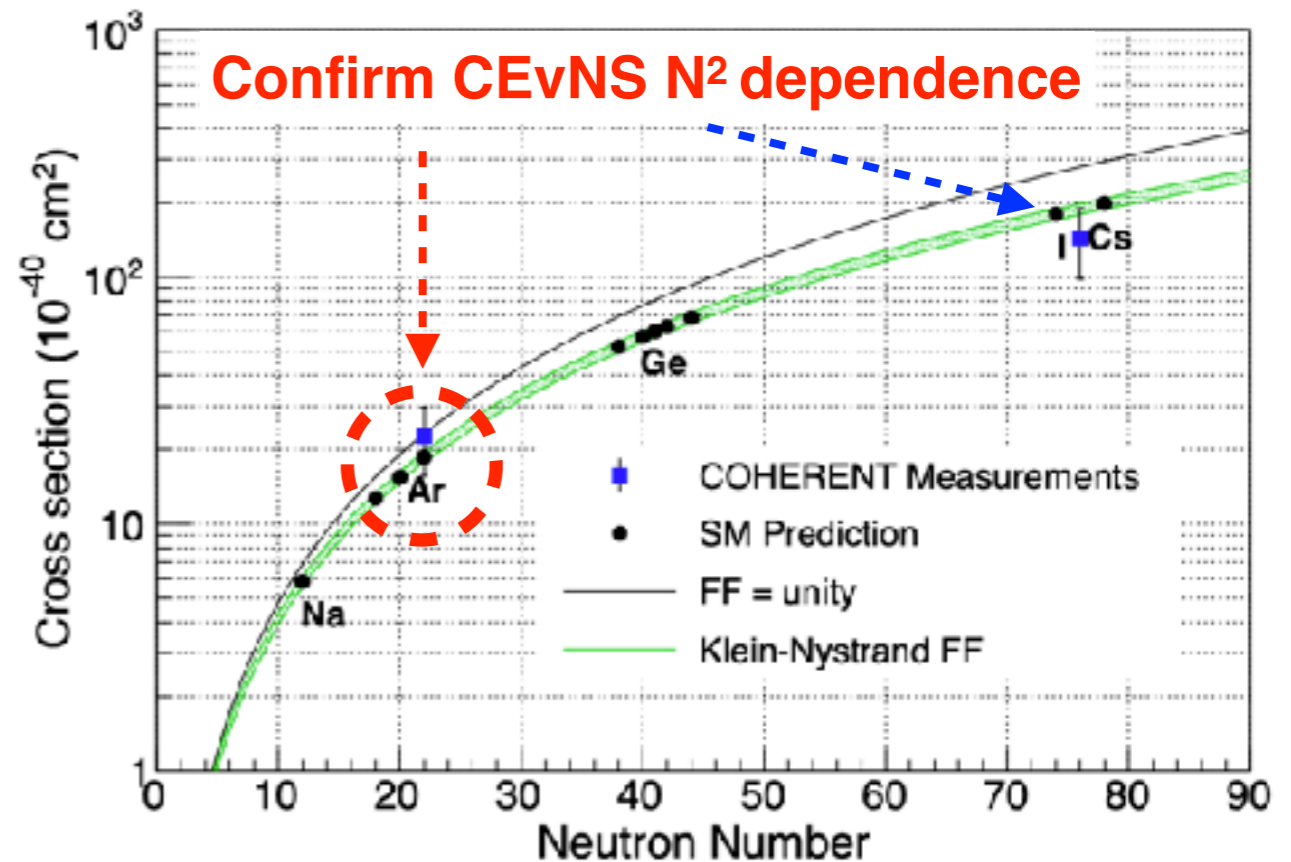
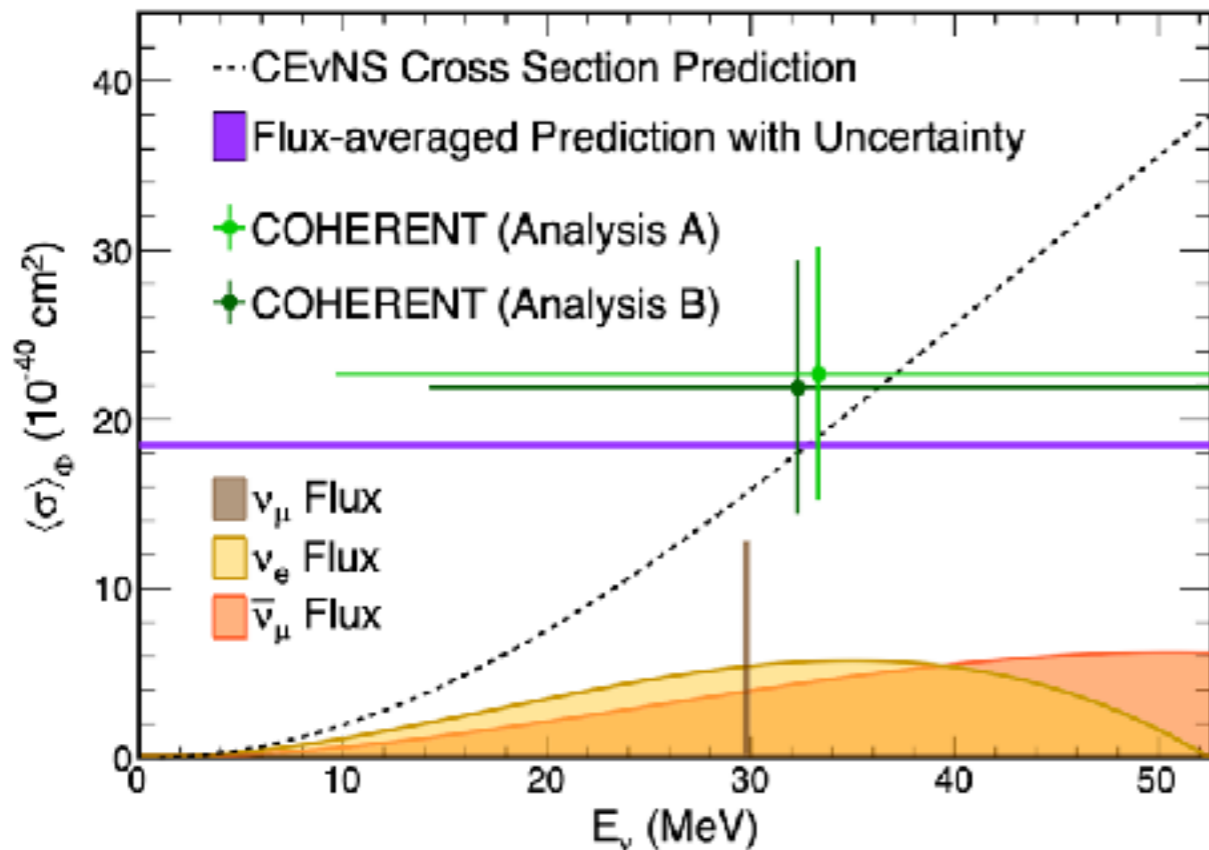



CENNS-1ton
Precision Measurement of the CEvNS
and Future

CENNS-1ton Project

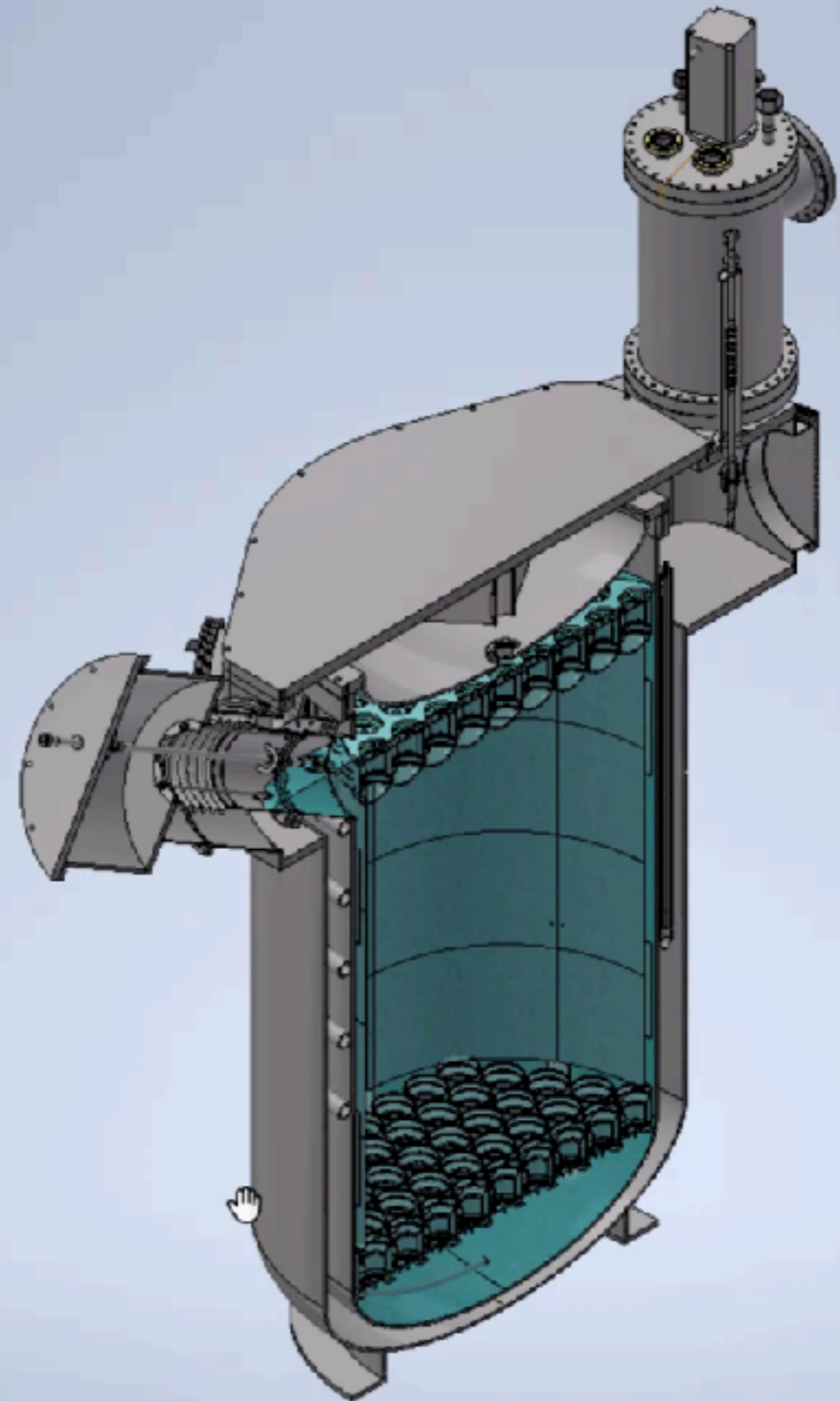
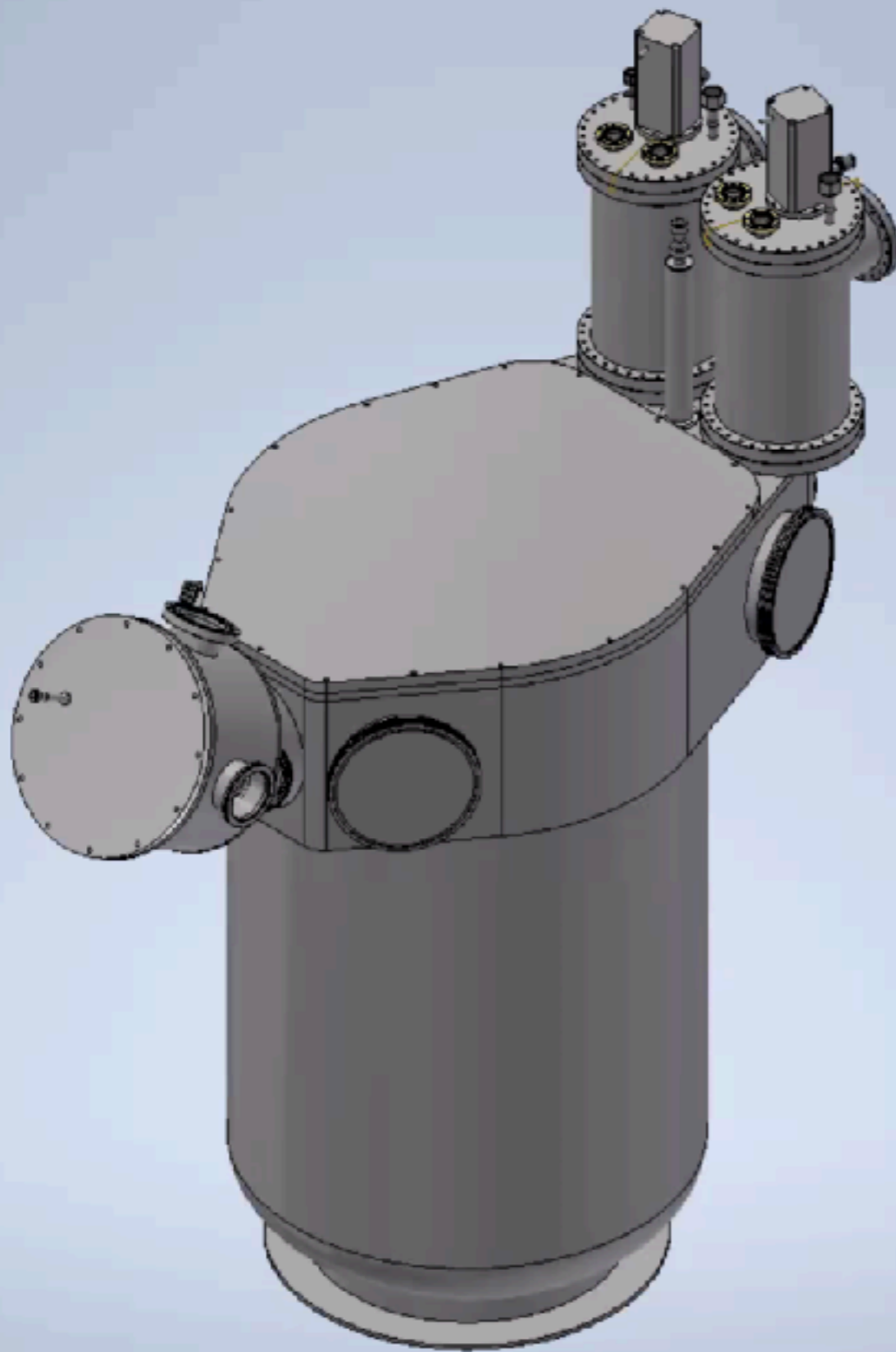

CEvNS Physics

CEvNS Precision Measurement

- CENNS-1ton fiducial volume: 600kg
- **Over 4,400 CEvNS events/year**
- Measure CEvNS with 5% precision in 3 years with D2O detector measurements (neutrino flux)

	CENNS-10 (1.5 year)	CENNS-1ton (Events/year)
CEvNS	159	4400
BRN	563	4000
SSB	3131	92000

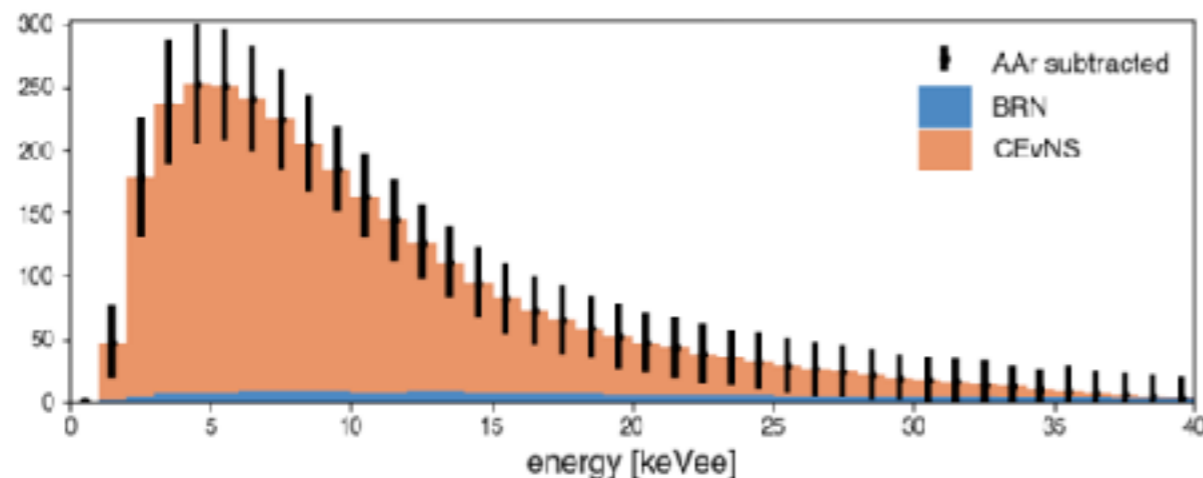
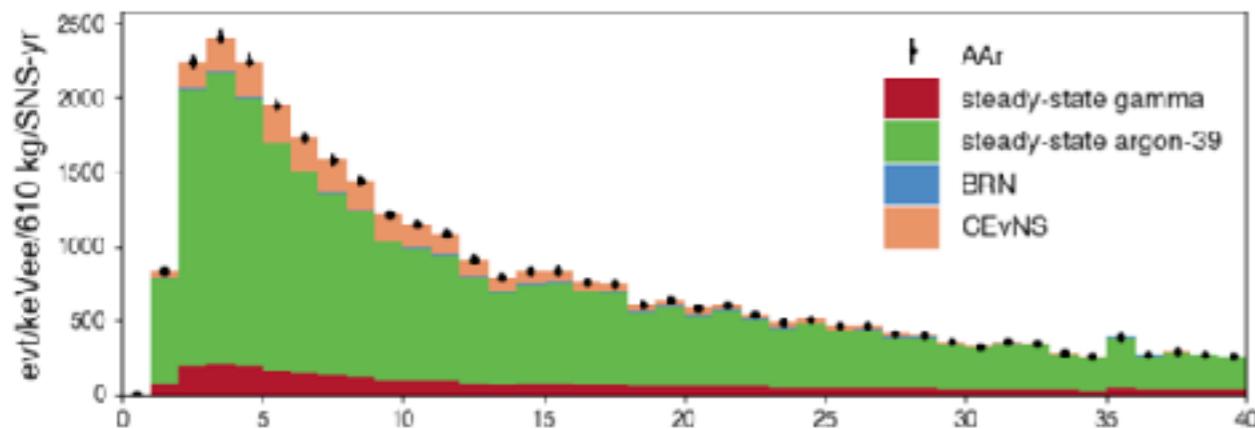

Non-Standard Interaction

- Factor 10 improvement compared with CENNS-10

$$\frac{d\sigma}{dT} = \frac{G_F^2 M}{2\pi} G_V^2 \left[2 - \frac{2T}{E_\nu} - \frac{MT}{E_\nu^2} \right]$$

$$G_V = ((g_V^p + 2\epsilon_{ee}^{uV} + \epsilon_{ee}^{dV}) Z + (g_V^n + \epsilon_{ee}^{uV} + 2\epsilon_{ee}^{dV}) N) F_{\text{nucl}}^V(Q^2)$$

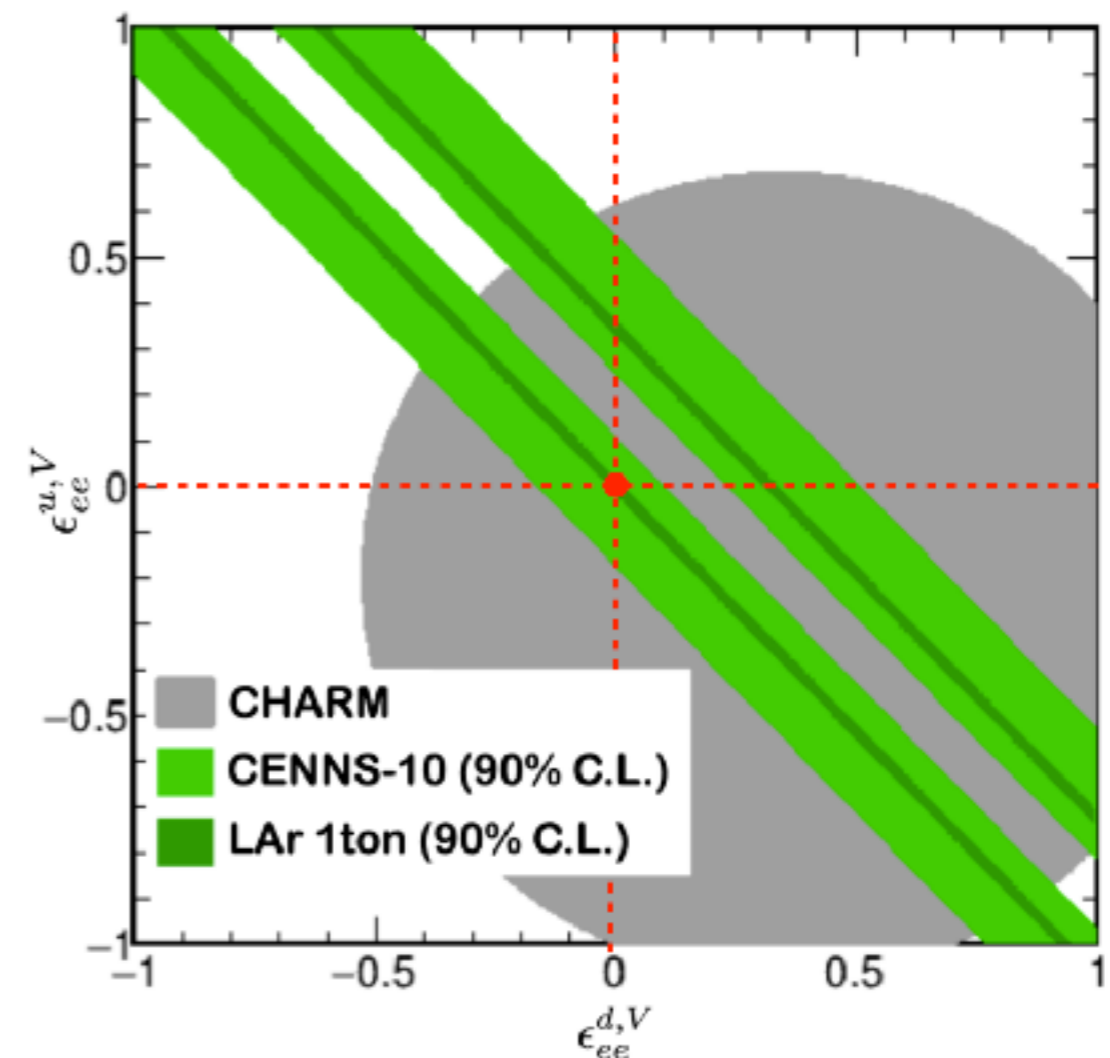

Underground Argon

Atmospheric Argon: ^{39}Ar β -decay isotope 1000 Bq/ton

Underground Argon: ^{39}Ar β -decay isotope 0.7 Bq/ton

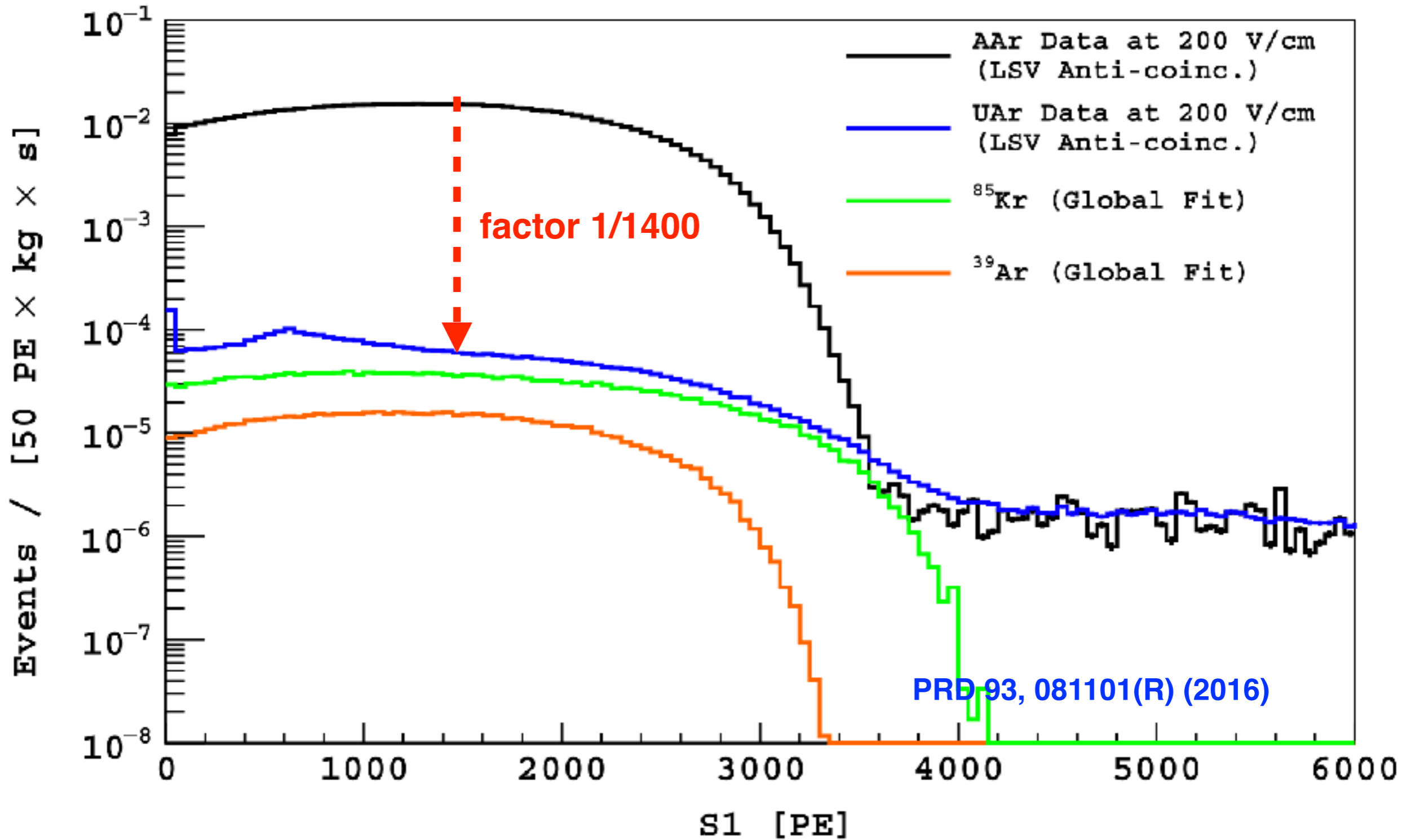

CEvNS Physics

Ar Neutron Radius

$$G_V \simeq g_V^n N F_n(Q^2) \quad F_n(Q^2) = 3[j_1(QR)/QR]e^{-Q^2 s^2/2}$$

$$R = \sqrt{\frac{5}{3}(R_n^2 - 3s^2)^2}$$

- CENNS-10 uncertainty 30% → R_n limit 4.33 fm (90%CL)
- CENNS-1ton uncertainty 4% → R_n measurement precision 10%

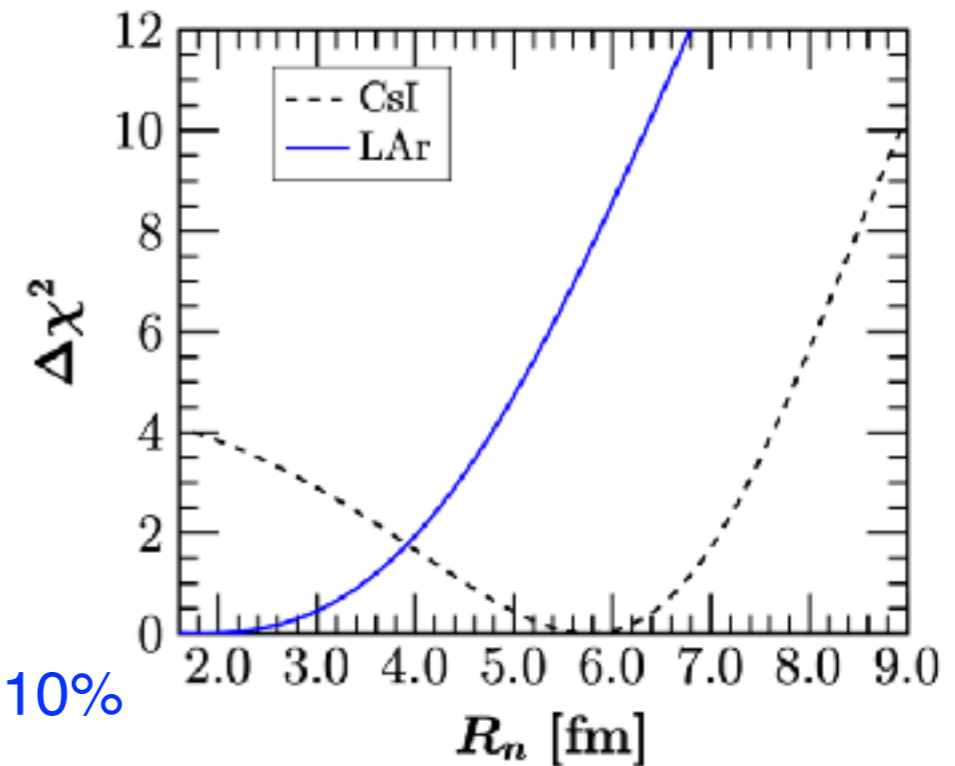

Ar inelastic scattering precision

- 1/100 smaller cross-section compared to CEvNS
- 1~100 MeV scattering energy
→ no obvious backgrounds

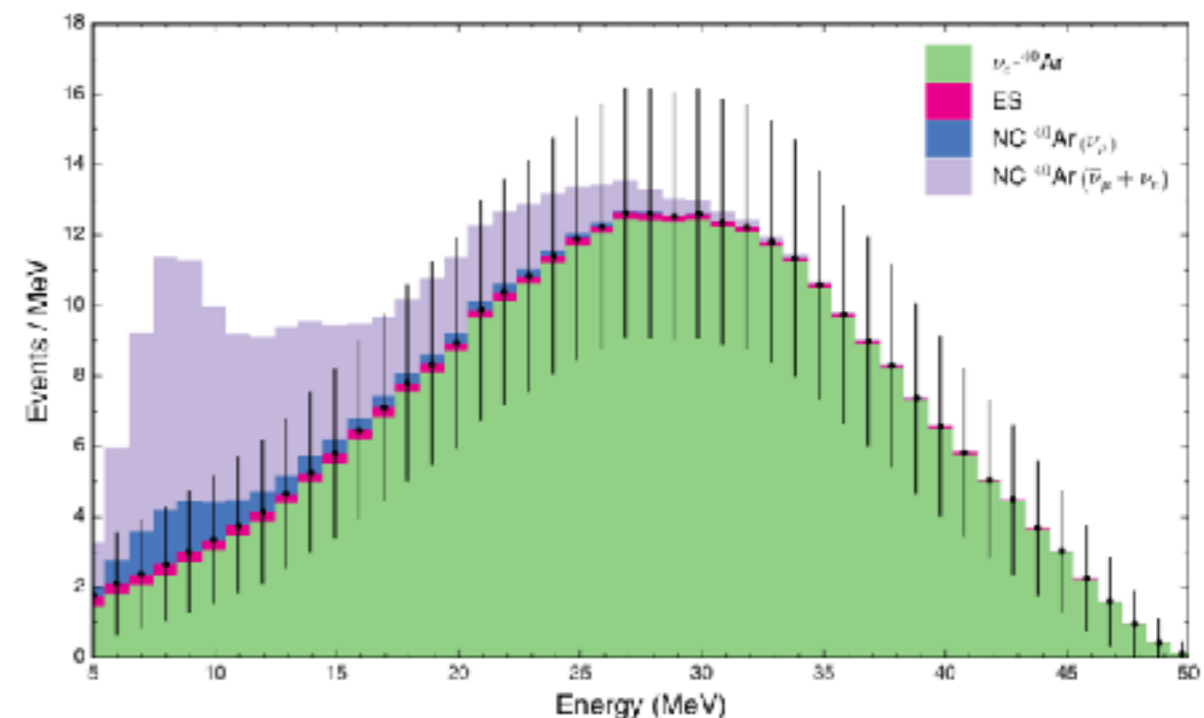

Dark Matter

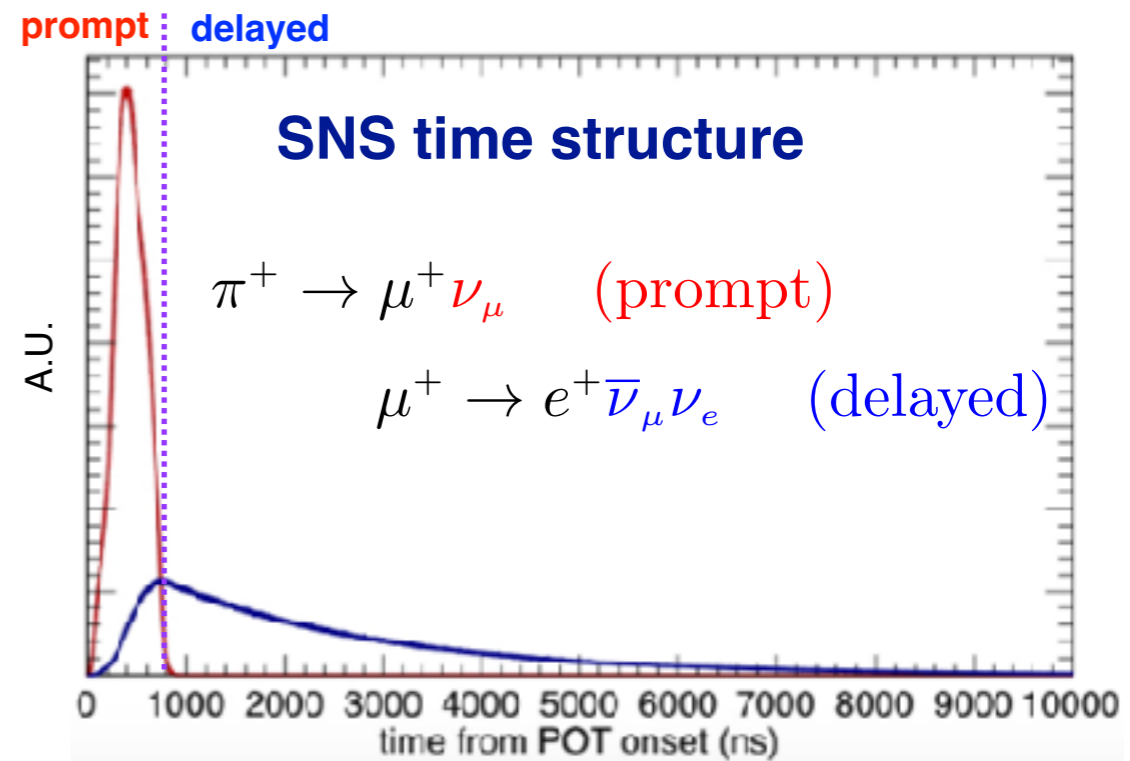
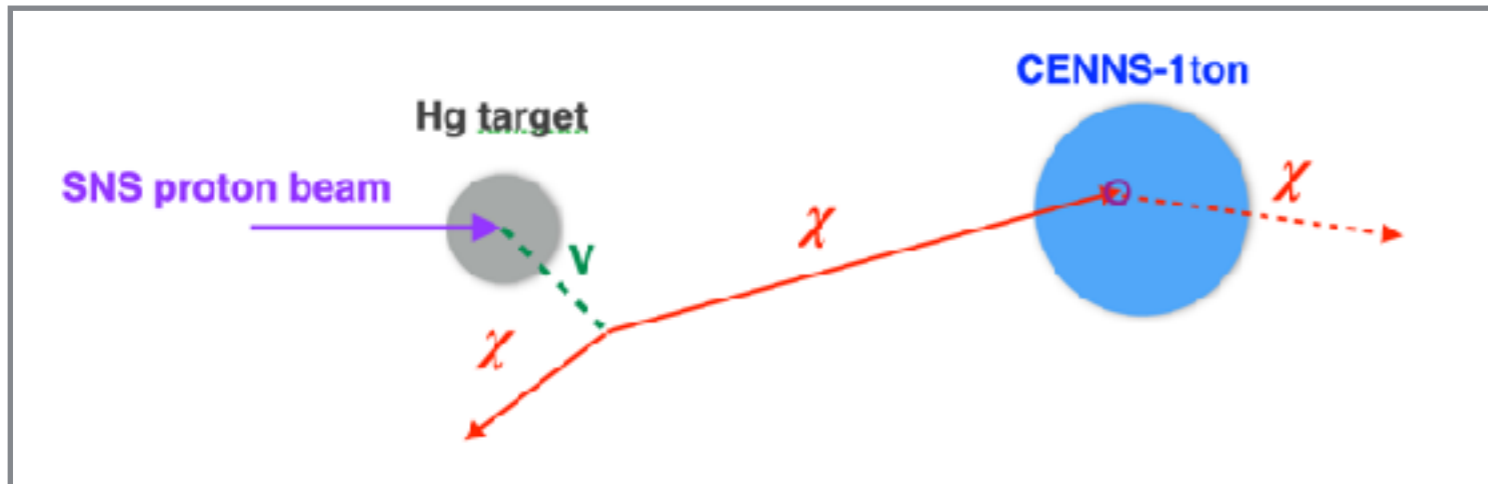

$$\mathcal{L} = A'(\epsilon e J_{EM}^\mu + \sqrt{4\pi\alpha'} J_D^\mu)$$

Search parameter $Y = \epsilon^2 \alpha' (m_\chi / m_\nu)^4$

- **CENNS-1ton (3 years operation)**

Prompt signal : CEvNS (~4450evt/3yr) + Dark Matter

Delayed signal : CEvNS (~7840evt/3yr)

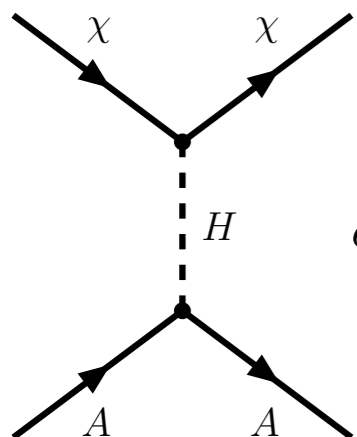

$$\sigma_{\chi N} \simeq \frac{4}{\pi} \mu^2 [Z f_p + (A - Z) f_n]^2 \propto A^2$$

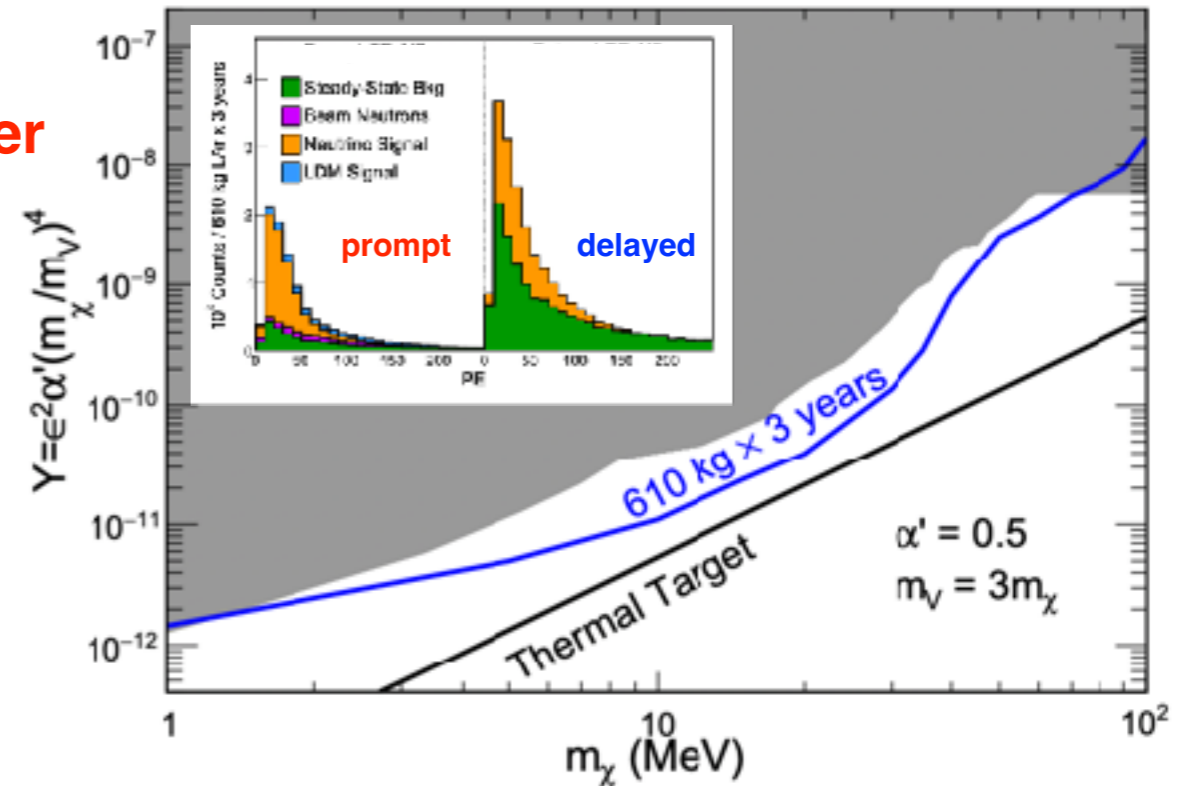

Neutrino Backgrounds of DM Search

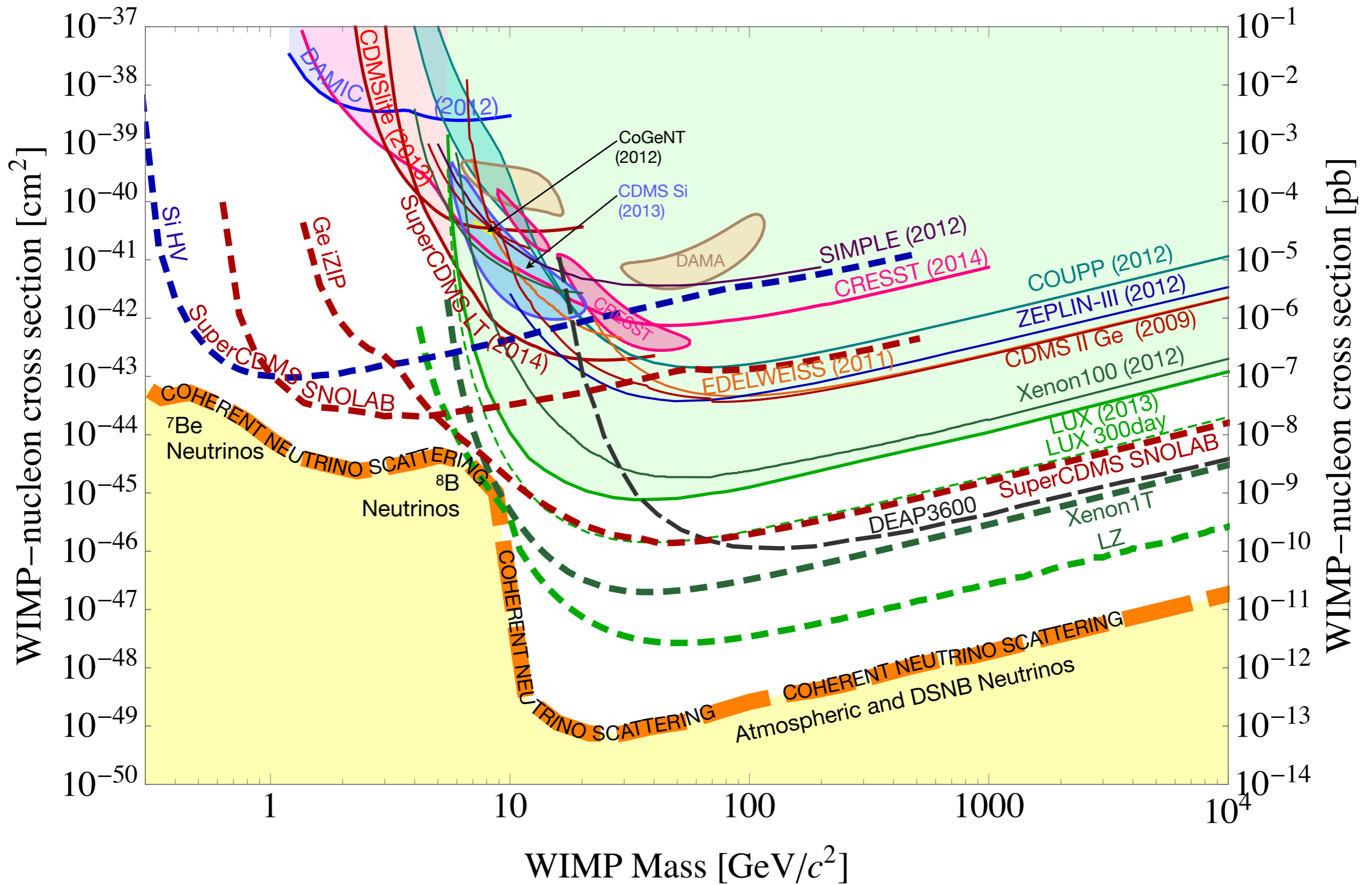

CENNS-1ton

Designed to address the limited space in the SNS Neutrino Alley

Snout:
signal cables,
vent, liquid fill

Optical Package
122 PMT Arrays
Teflon side wall
(TPB coating)

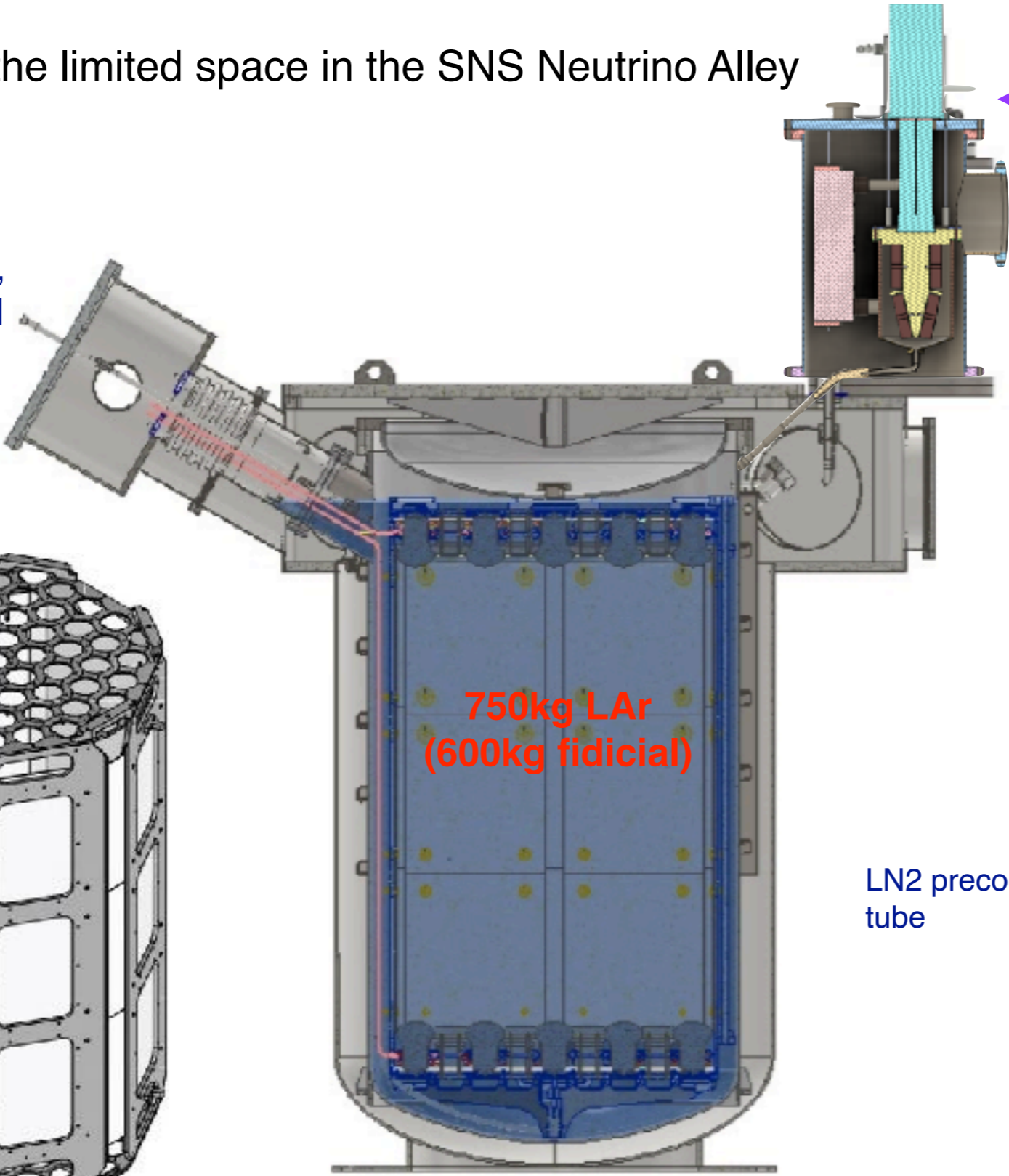
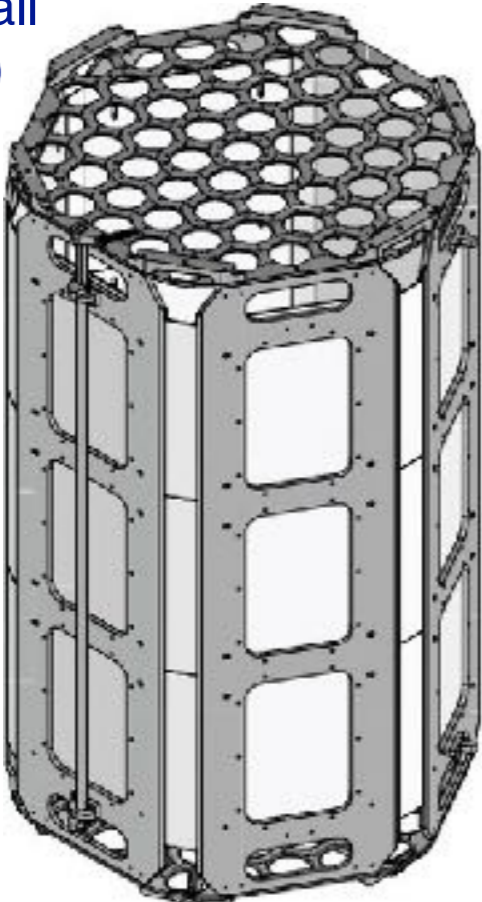

750kg LAr
(600kg fiducial)

LN2 precooled
tube

Two PT-90 Cryocoolers
~100W at LAr temperature
Base temperature: 30K

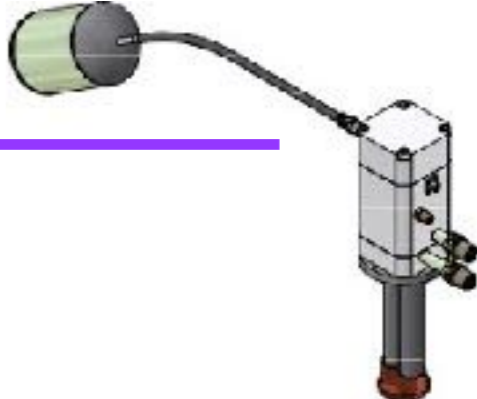

LAr chamber



Main Chamber Built in Korea

- Fabricated by Yunsel Inc. (Korea)
- P/O to delivery: ~8 months
- 45PSIG Pressure Certificate

NO. 2023 - 56385 - 1

KCS

Safety Certificate

(Name of Manufacturer) Sepeun Plant Tech Co., Ltd Geumsan Bran
(Address) (327-14)283, Motgol-ro, Chubu-myeon, Geumsan-gun, Chungcheongnam-do, Republic of Korea

The following product produced by the above company has been authorized for the use of the  Mark as the product has satisfied the safety and health standards stipulated in the article 84 of Industrial Safety and Health Law.

PRODUCT
PRESSURE VESSEL

TYPE - MODEL(CAPACITY - GRADE)
LV-100 (LV-100 / 0.58 ml)

CERTIFICATION No.
23-AG1AE-01637

SAFETY CERTIFICATION STANDARDS
Notification No. 2020 - 41 - of the Ministry of Labor

CERTIFICATION CONDITION
It is only for this product.

Date : 19/06/2023
Signature *Jung S. Kim*

President of Korea Occupational Safety and Health Agency



Korea Occupational Safety and Health Agency

CENNS-1ton@SNU

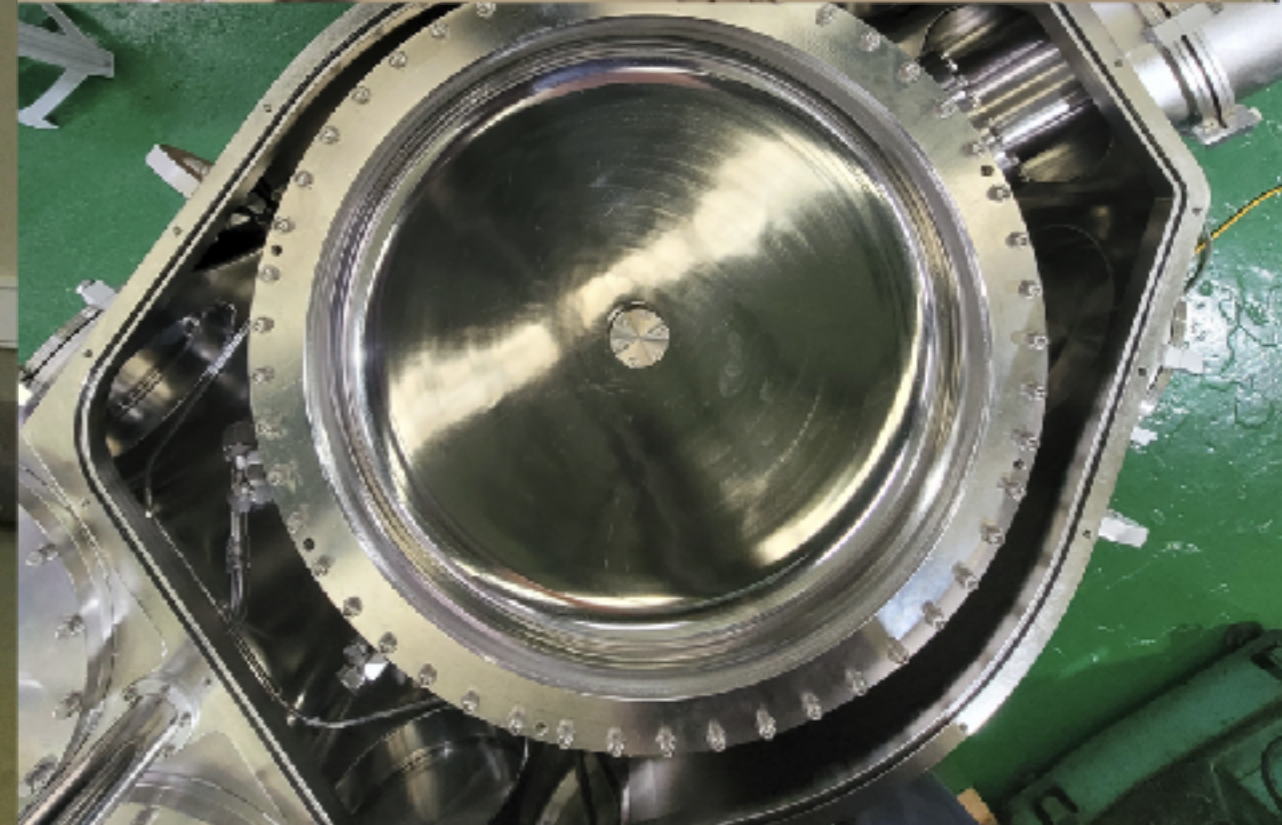

CENNS-1ton@SNU



CENNS-1ton Ar Condensing (SNU)

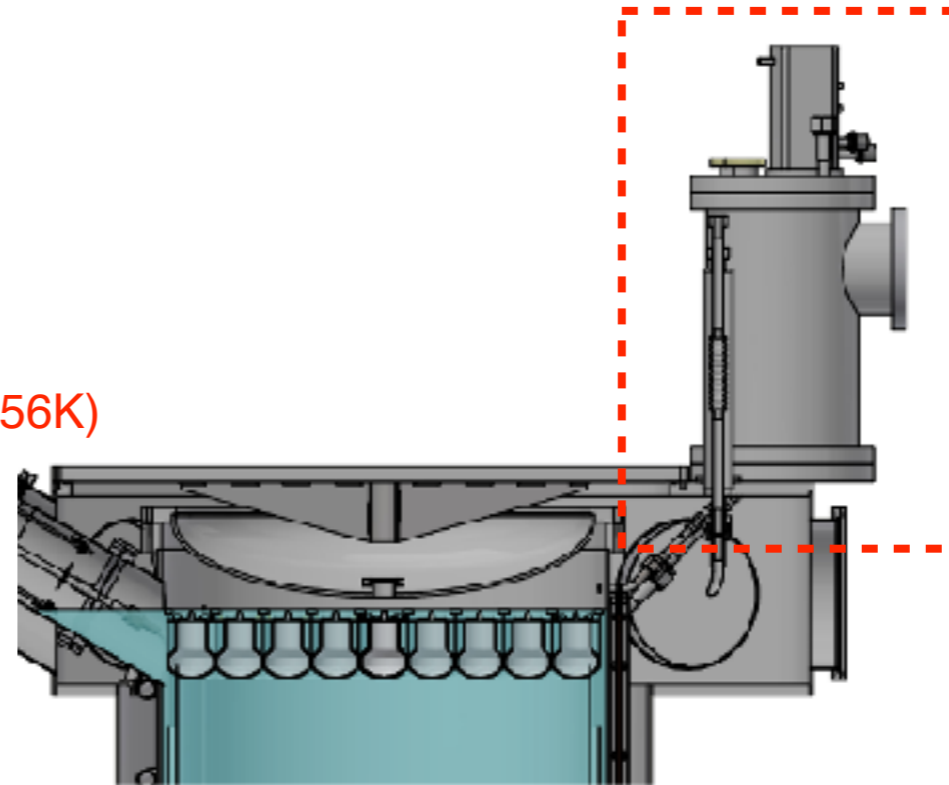
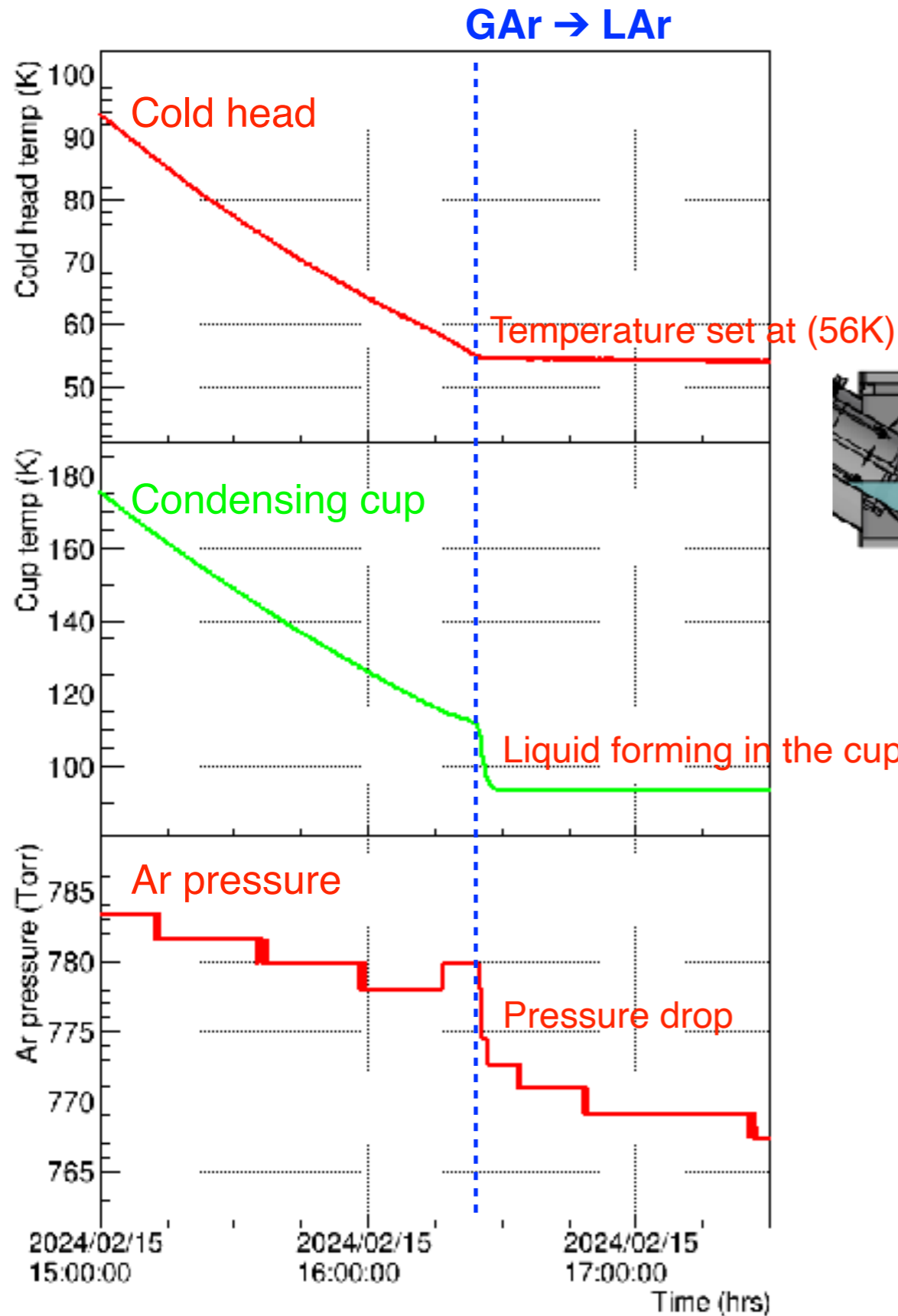

Copper block

Cold head

Condensing cup

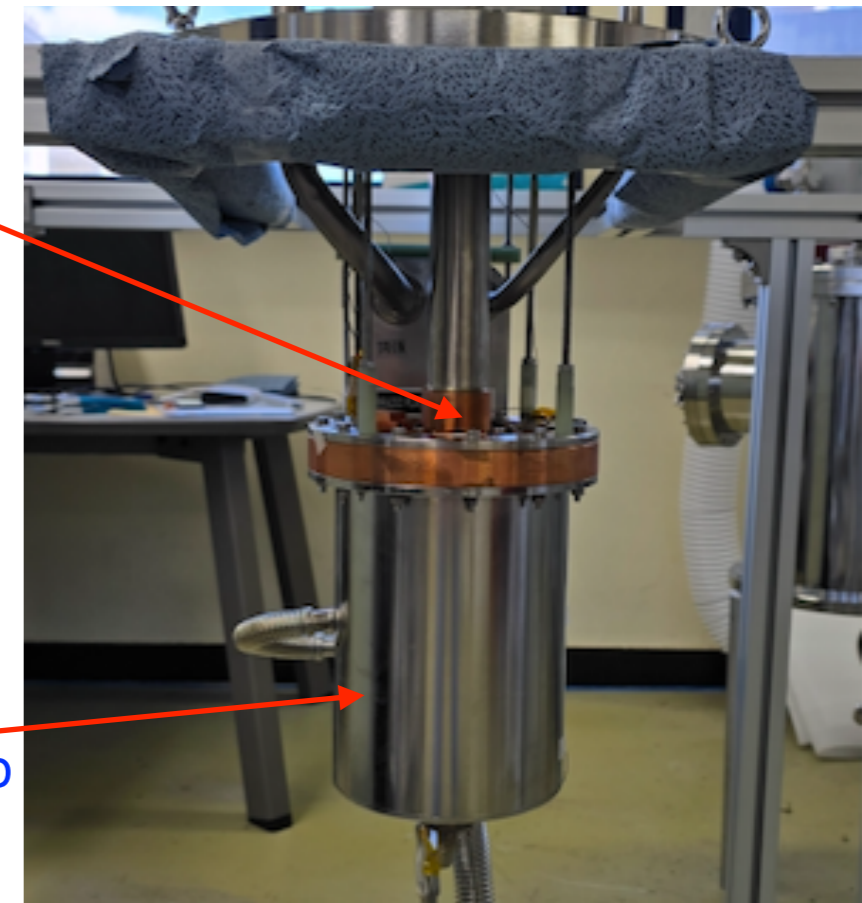

CENNS-1ton LAr Transfer (SNU)

LAr

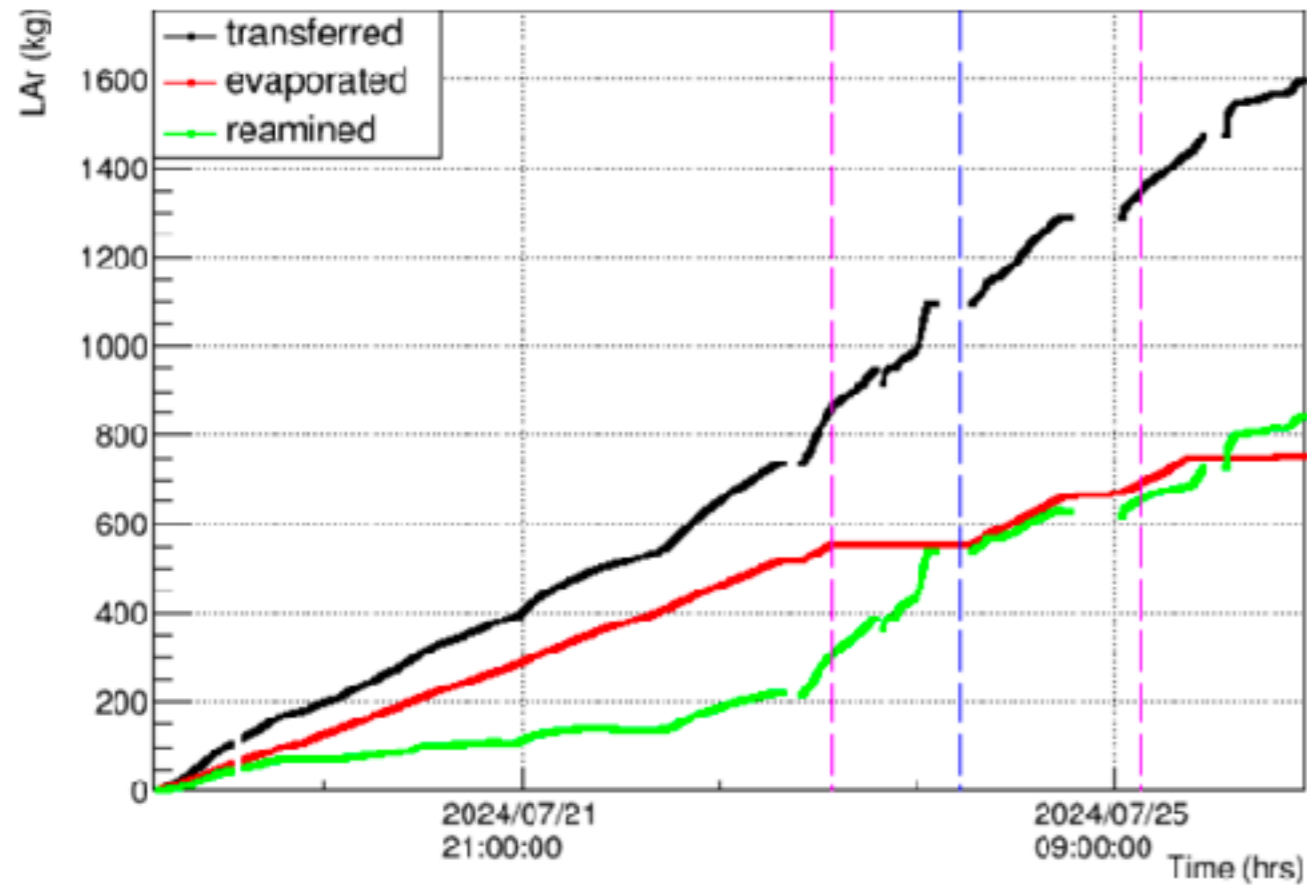
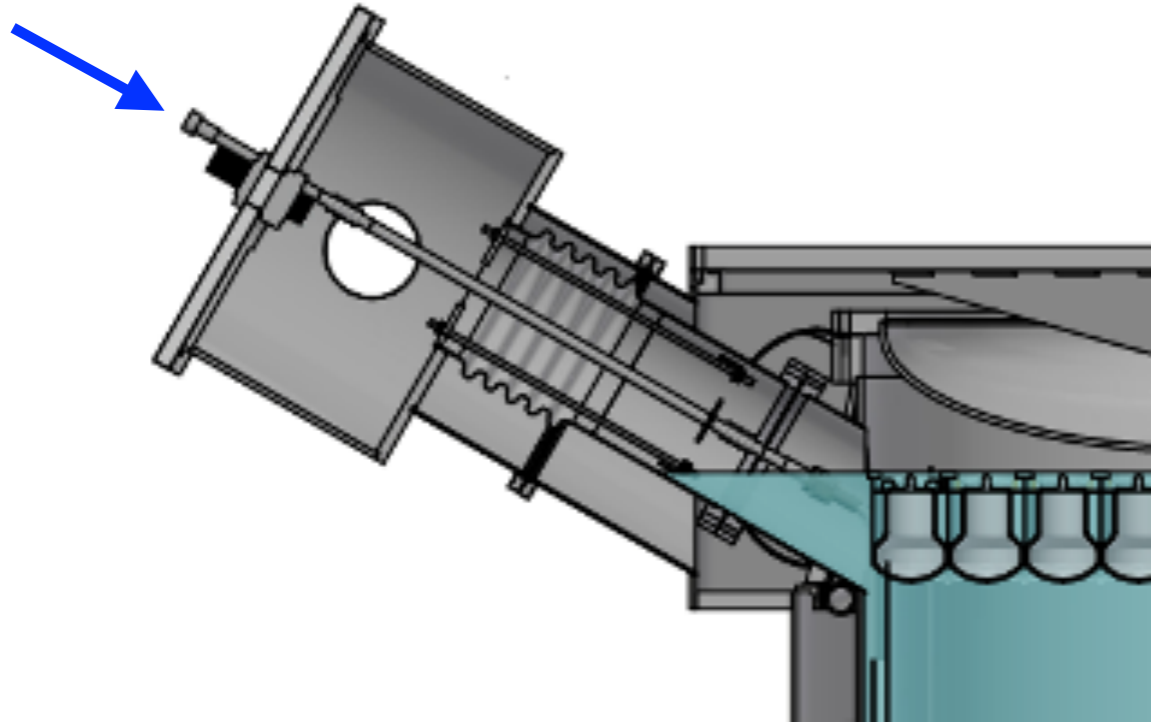

SNU to ORNL (2024.10)

Shipping to ORNL (Sep. ~ Oct. 2024)



Main Chamber Assembly

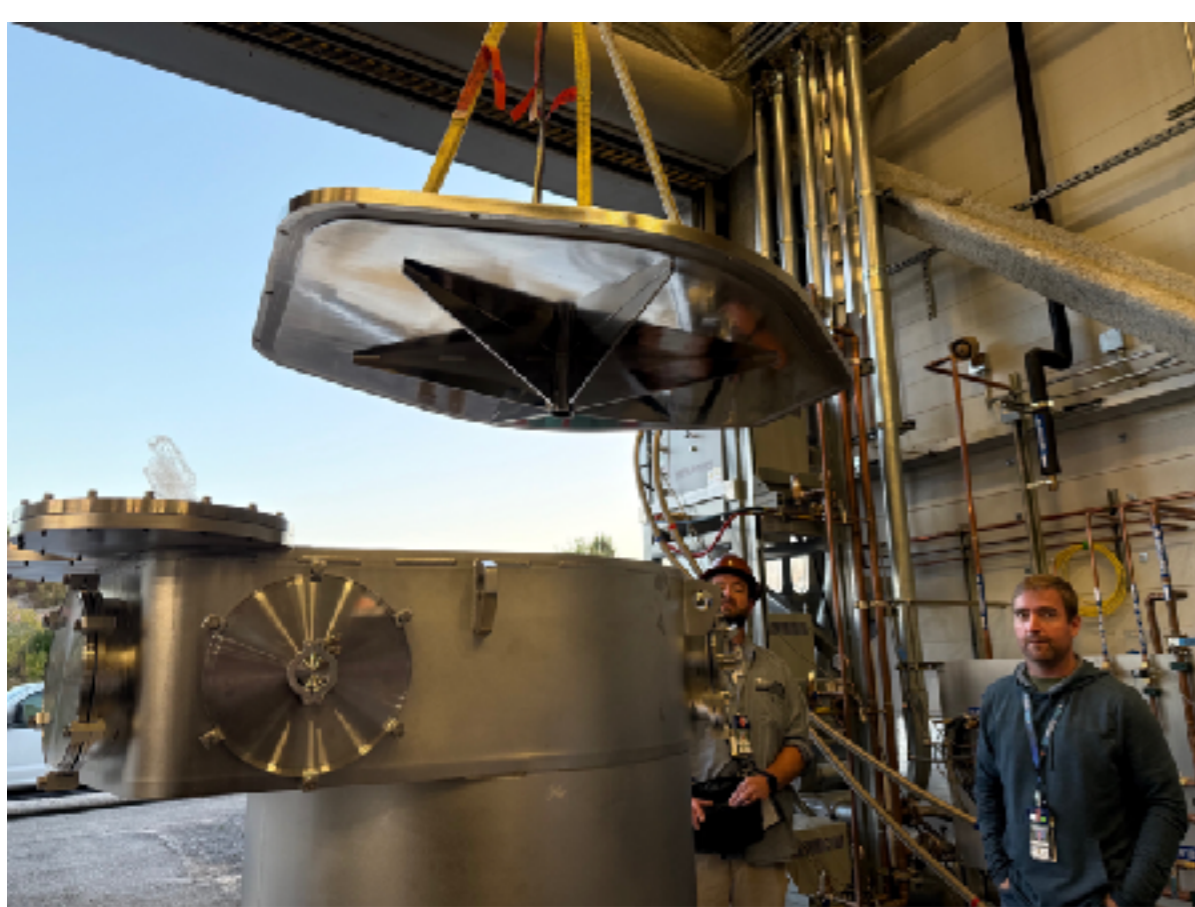

Super Insulation

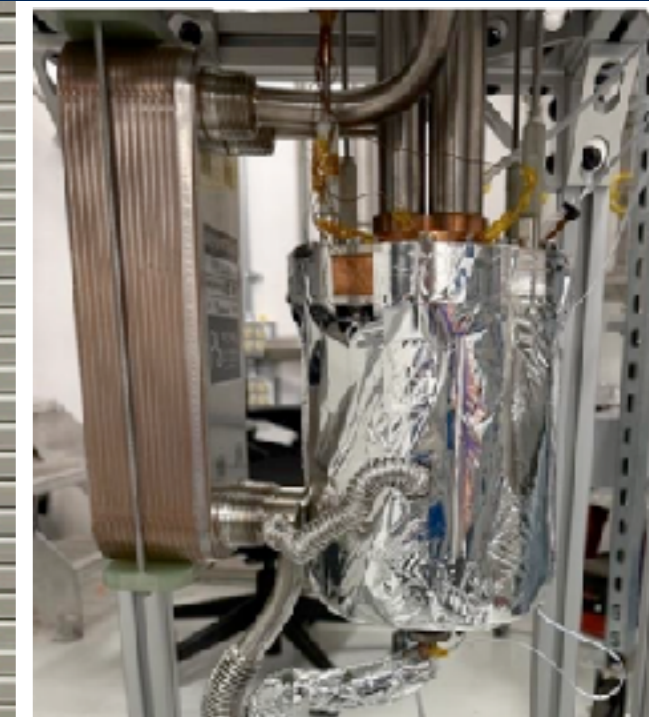

CENNS-1ton@ORNL

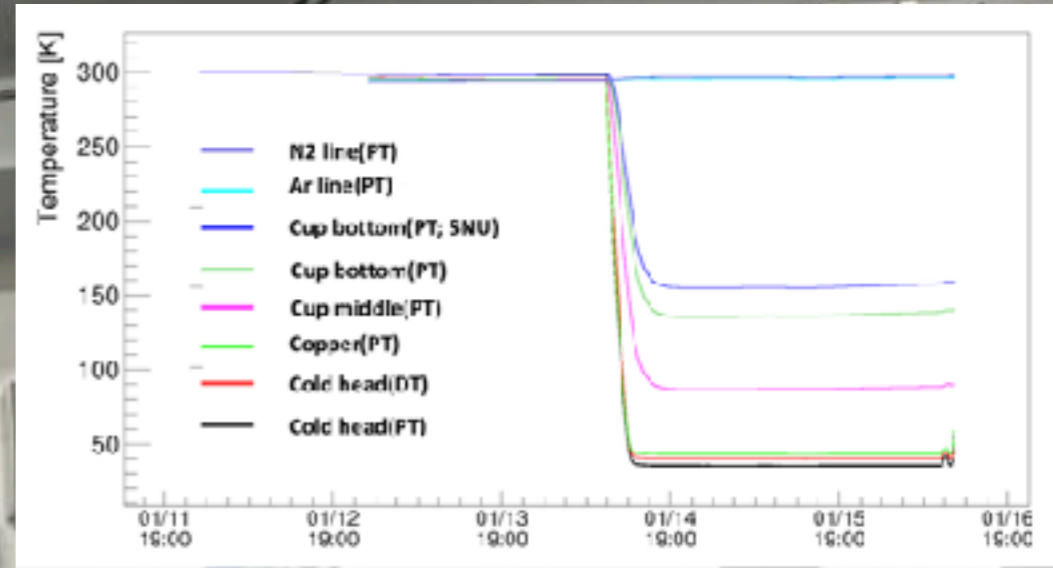
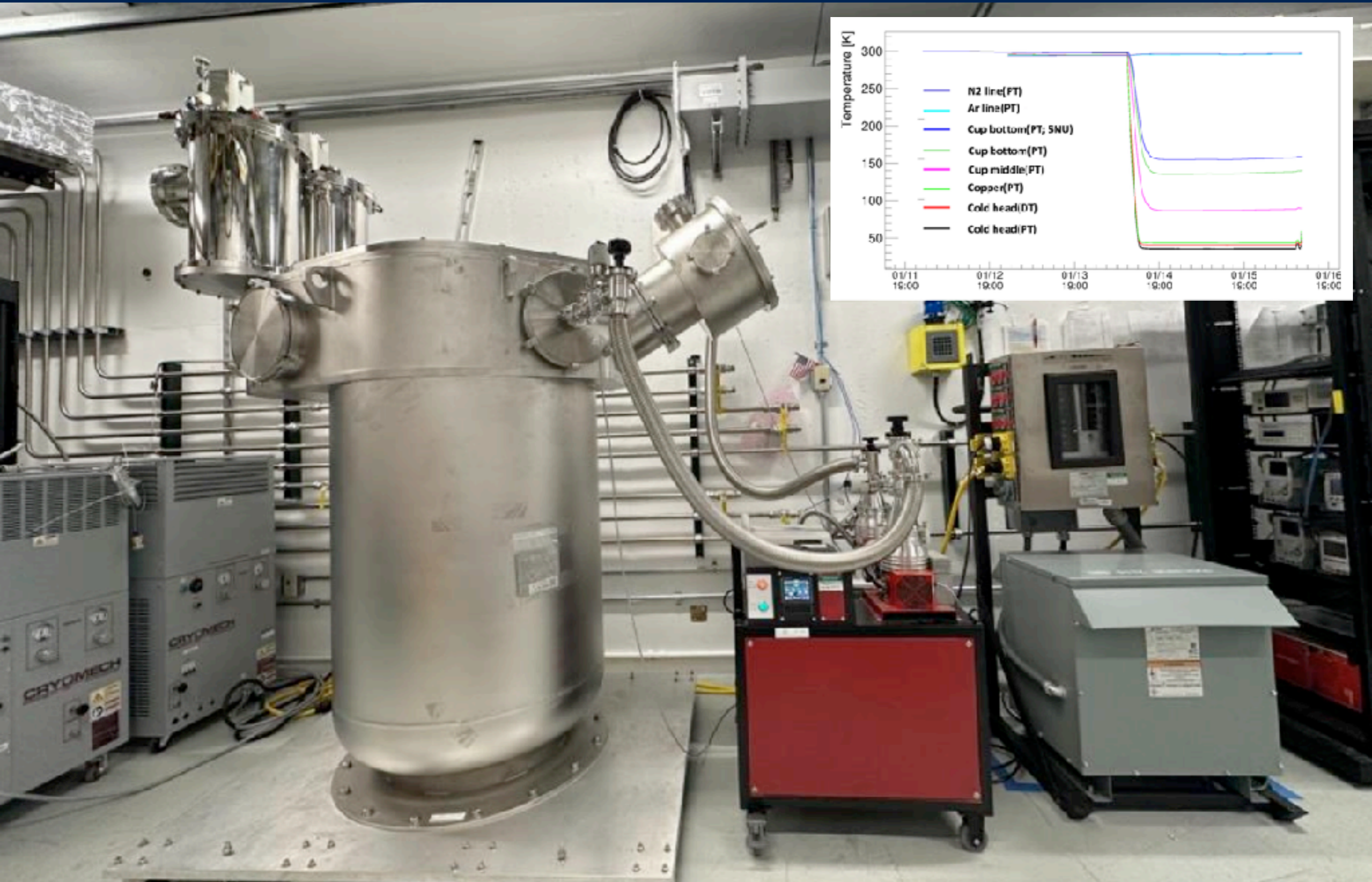

CENNS-1ton Gas System

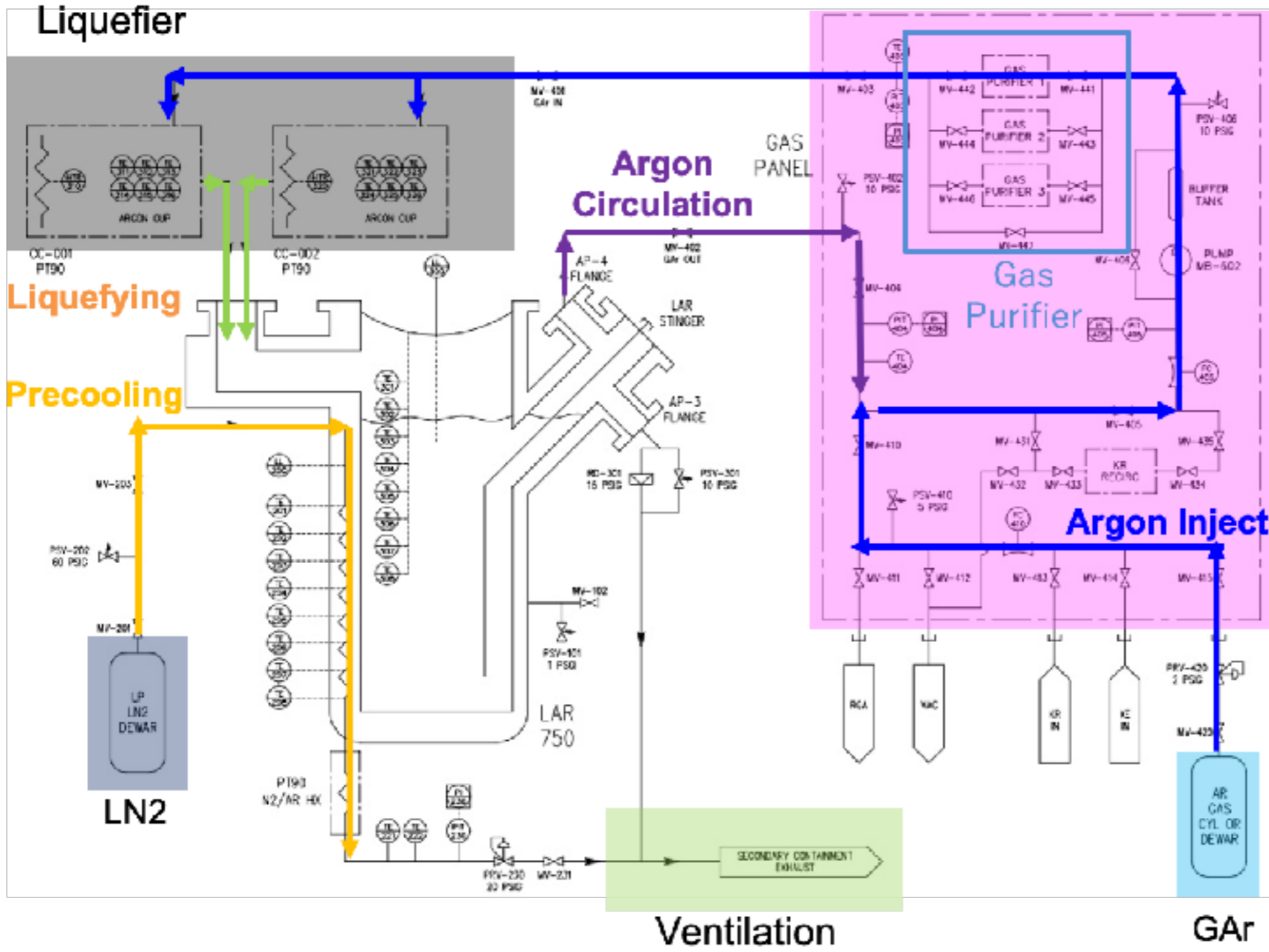

PMT



Hamamatsu R14374	Property
Surface	3 inch Diameter
Dark current	50nA
Quantum Efficiency	27.5%
Gain	10^7 @ 1300V
Timing Resolution	2ns

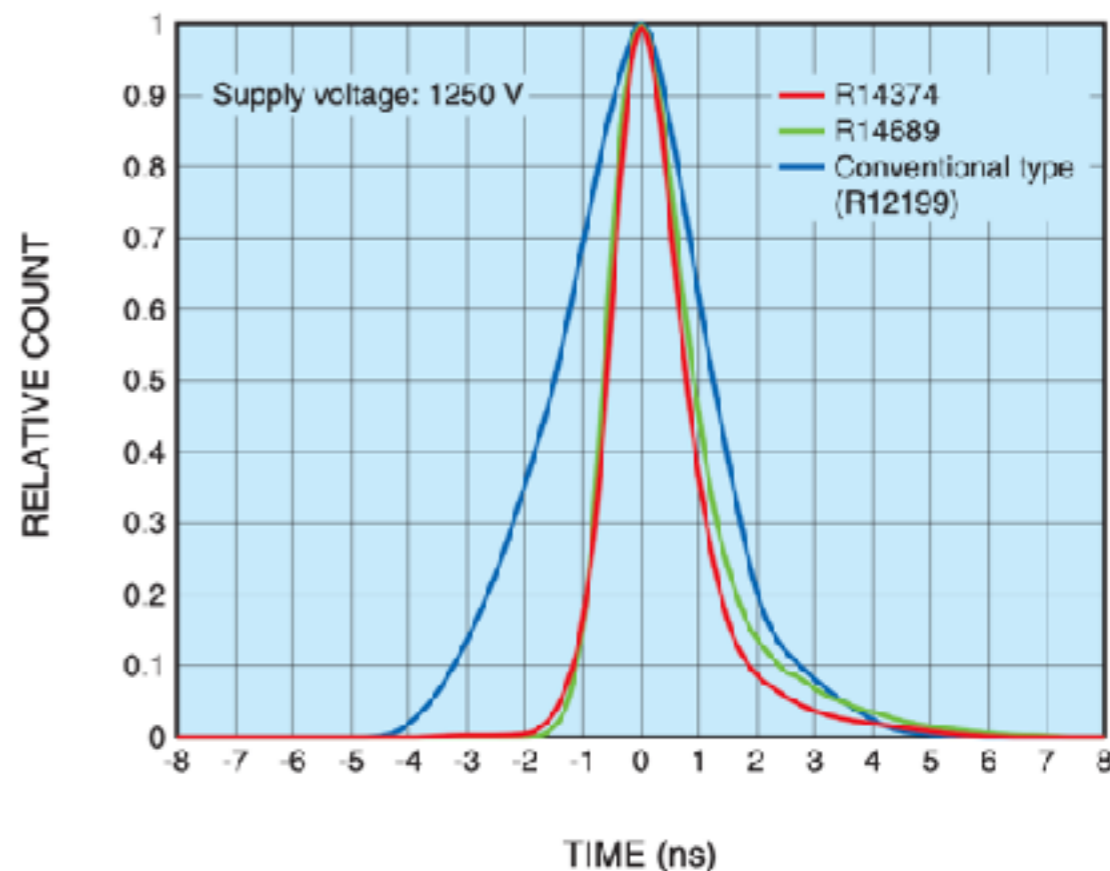
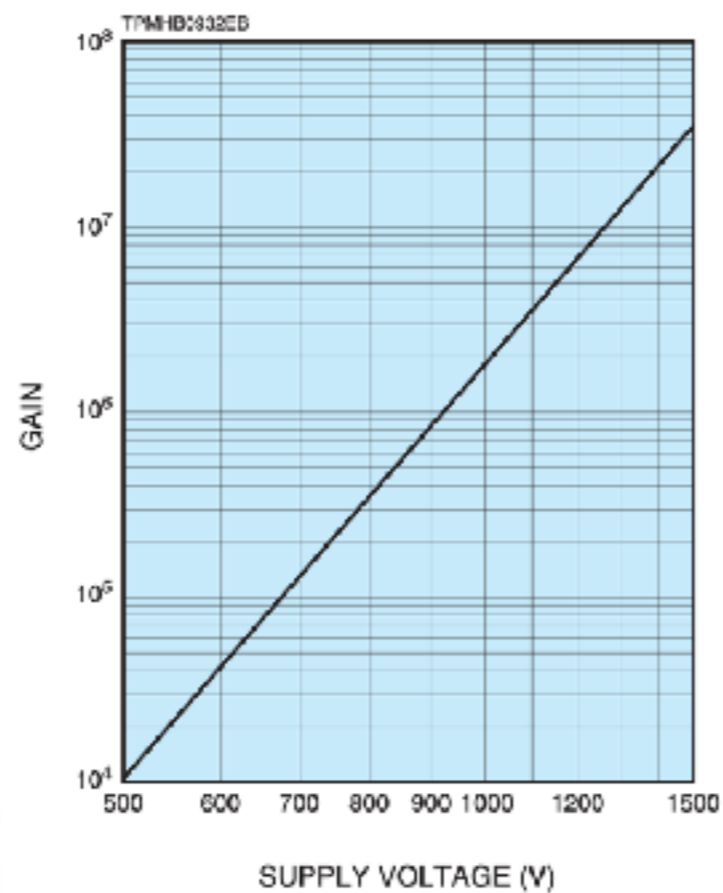
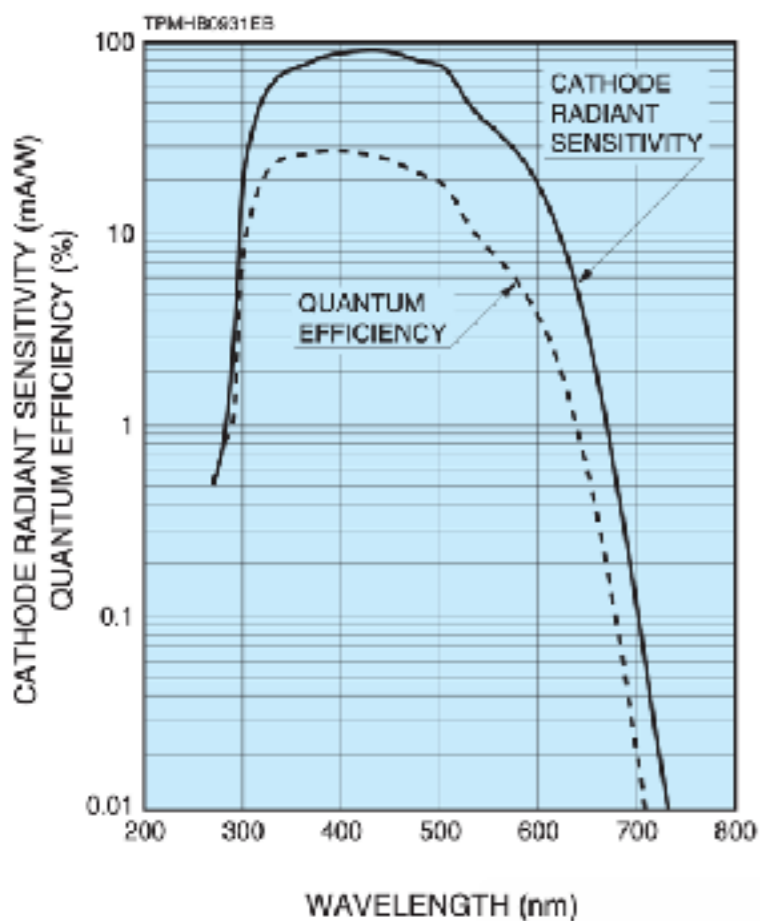

TPB Coating

- TPB absorbs $\lambda = 128 \text{ nm}$ \rightarrow emits $\lambda \sim 425 \text{ nm}$
- $\sim 0.2 \text{ mg/cm}^2$ (ideal): thickness $\sim 4.5 \mu\text{m}$
- TPB coating on PMTs, PTFE panels

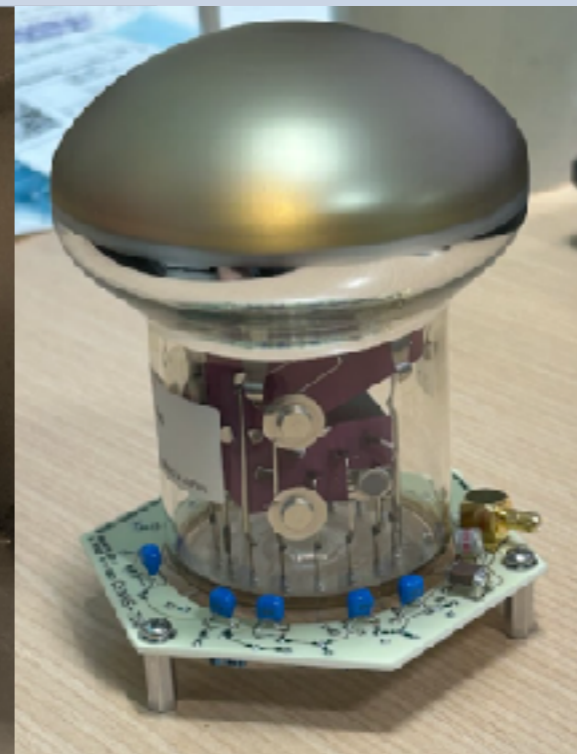
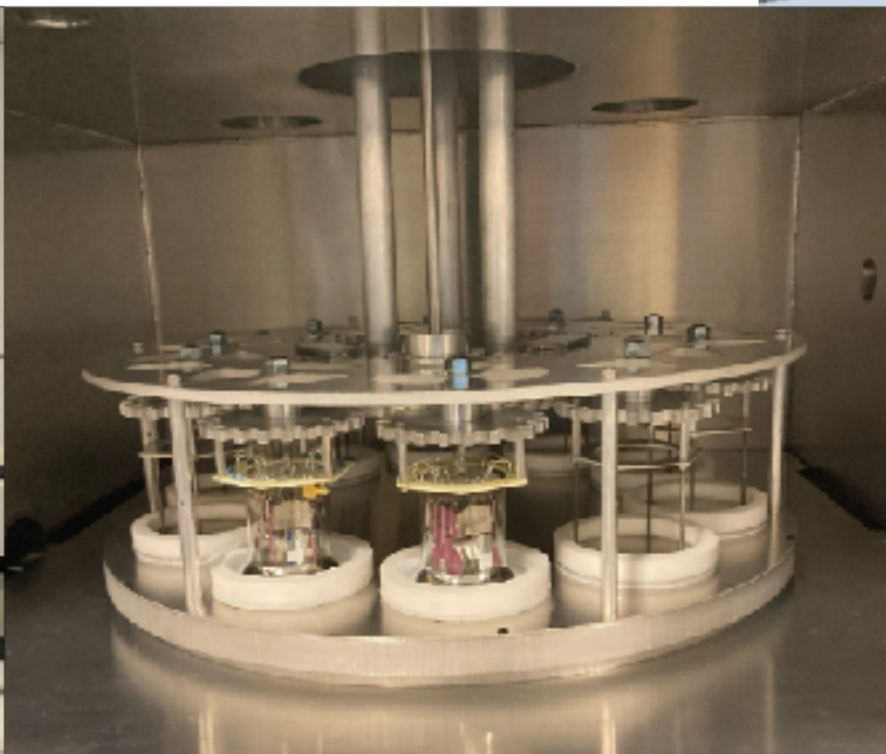
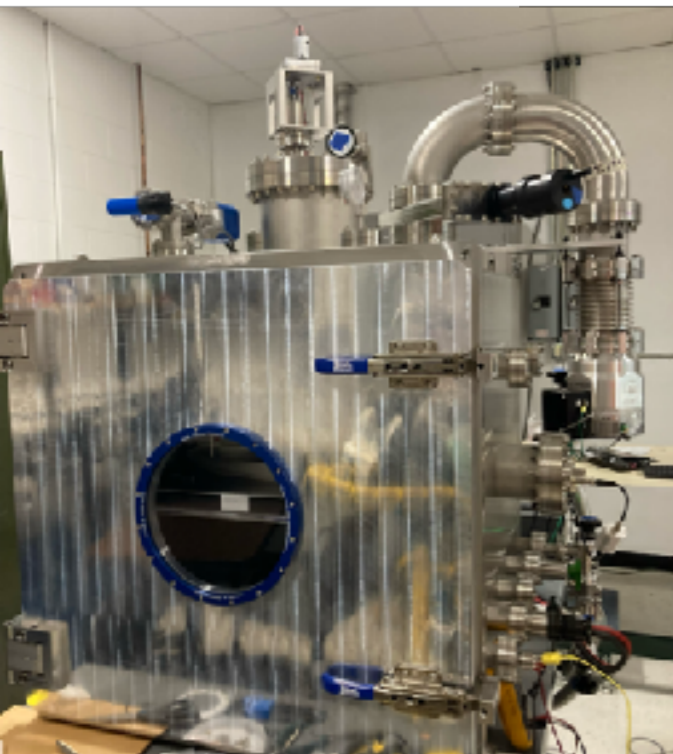
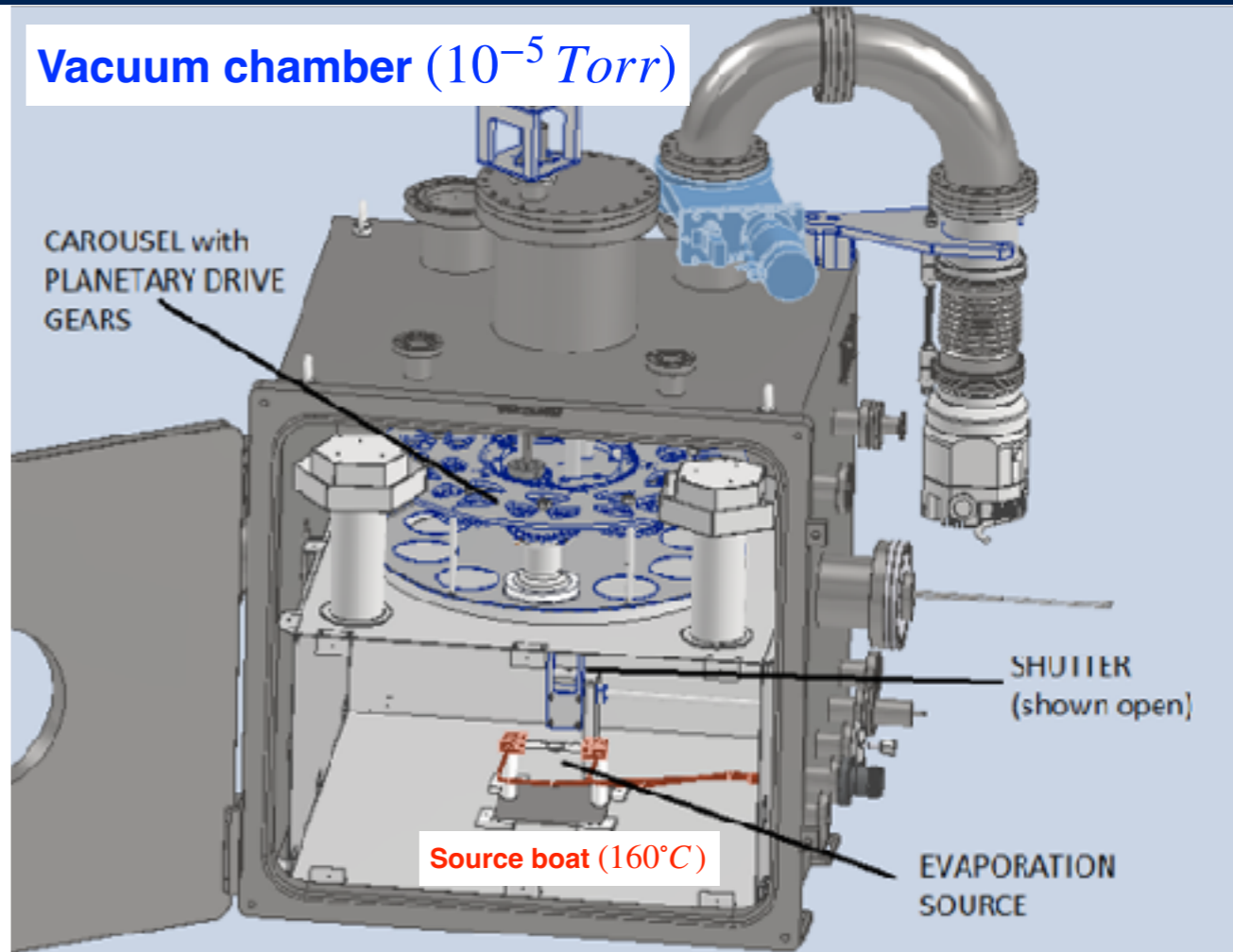
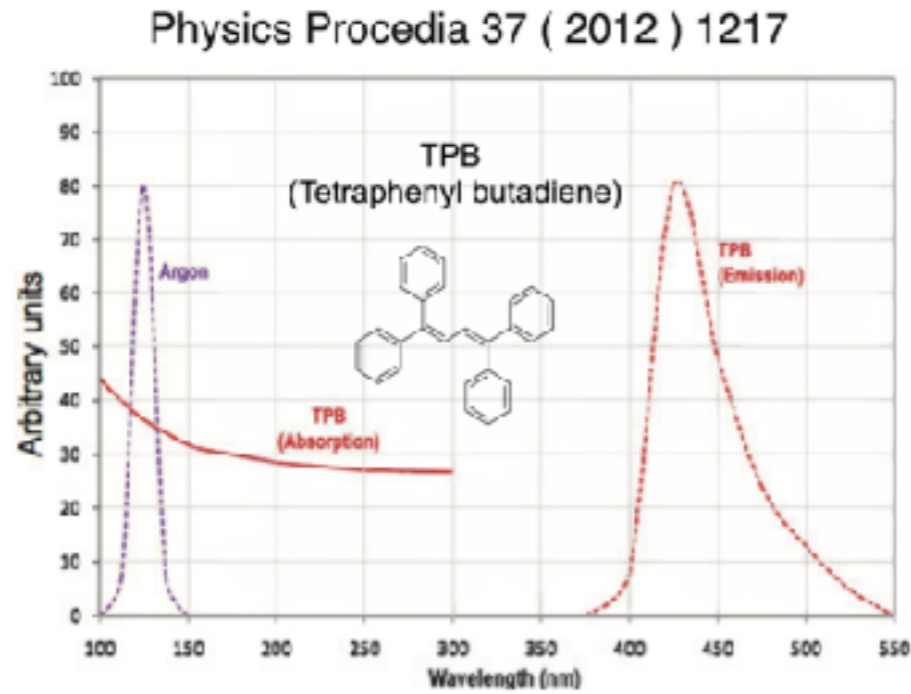

TPB Coating Optimization

- Re-emission test: Illuminated a coated and a blank plate using the excitation spectrum (250~300nm)
- Transmission test: Illuminated a coated and a blank plate using the halogen light source (500~700nm)
- Three different thickness measurements to cross-check:
 - Thickness monitor during coating
 - Direct mass measurement (witness plate)
 - Profiler measurement of the thickness monitor crystal

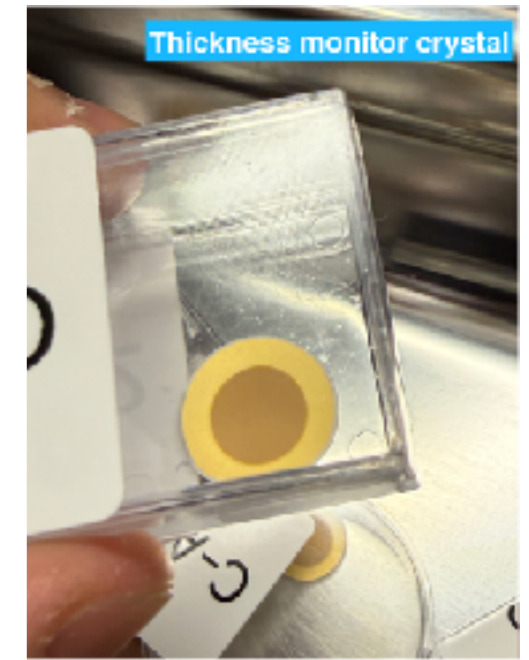

Reemission spectra

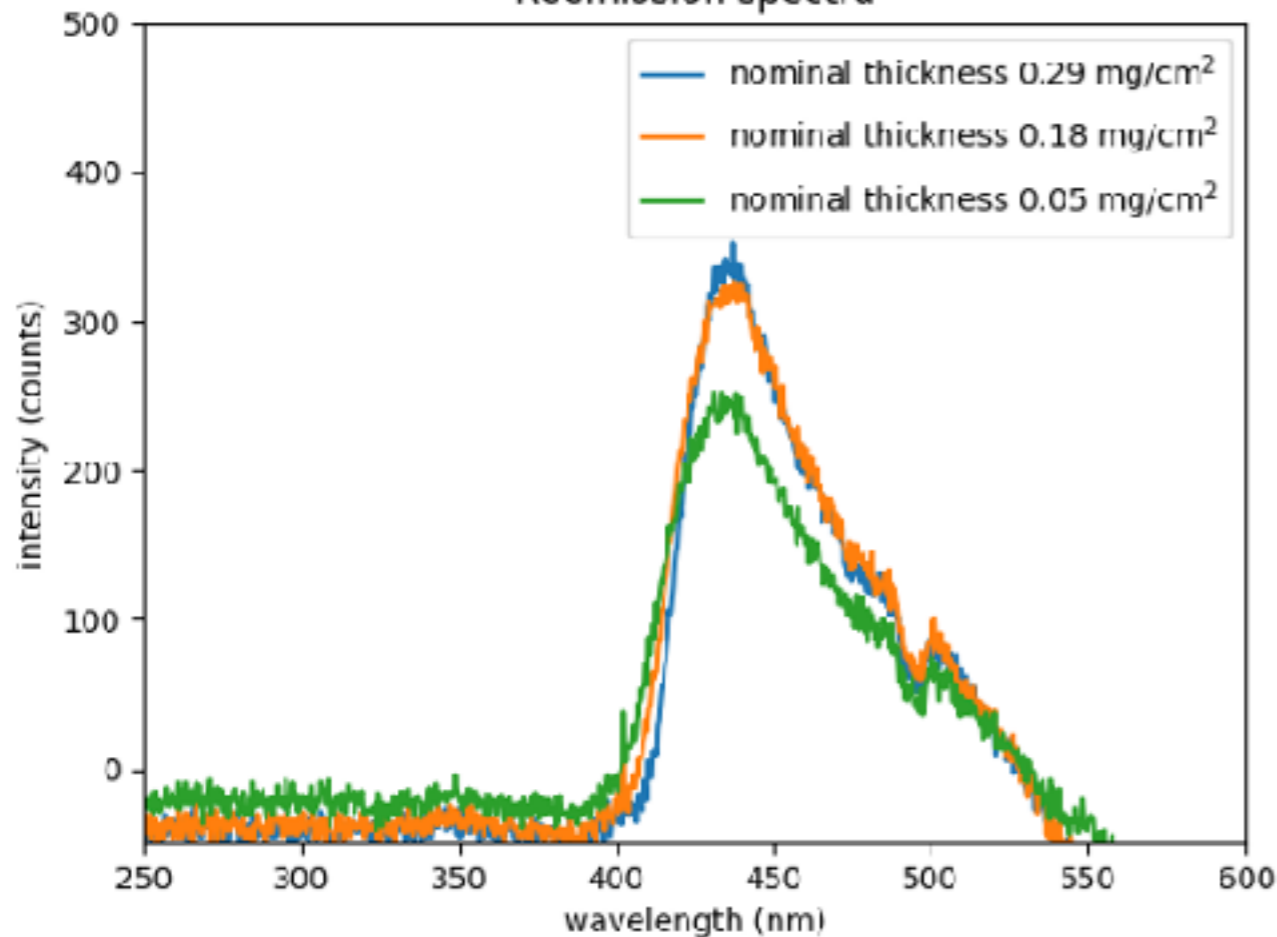

Coated transmission spectra

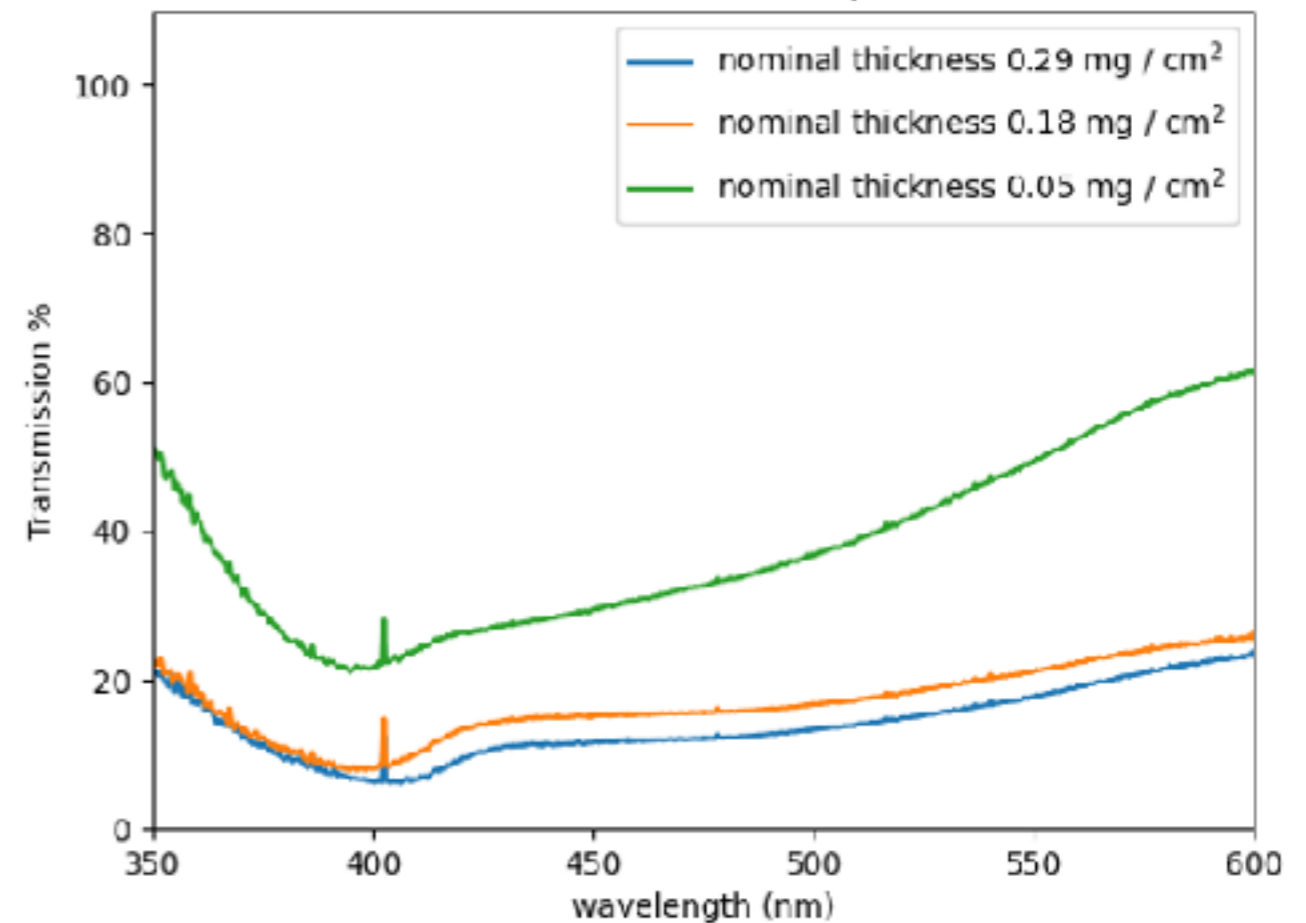

TPB Coating

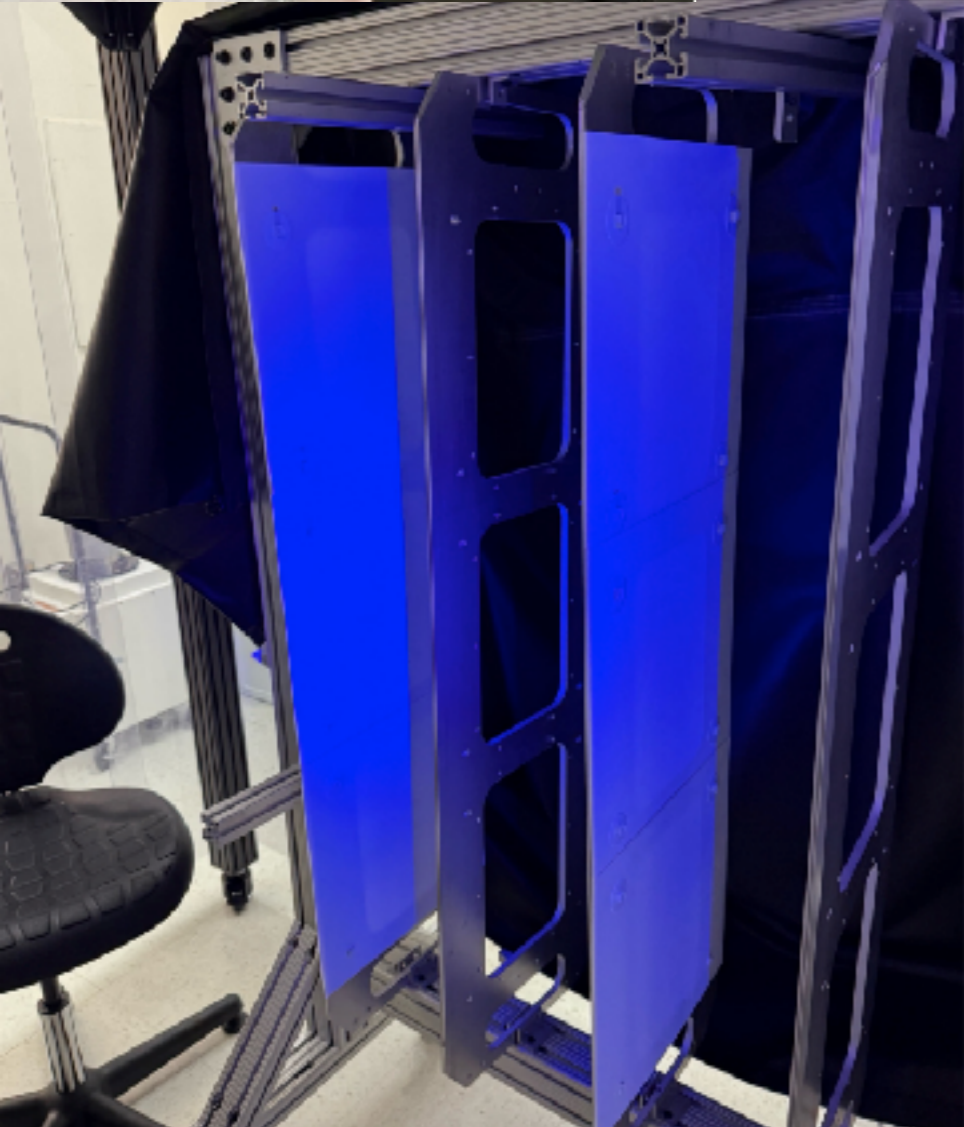
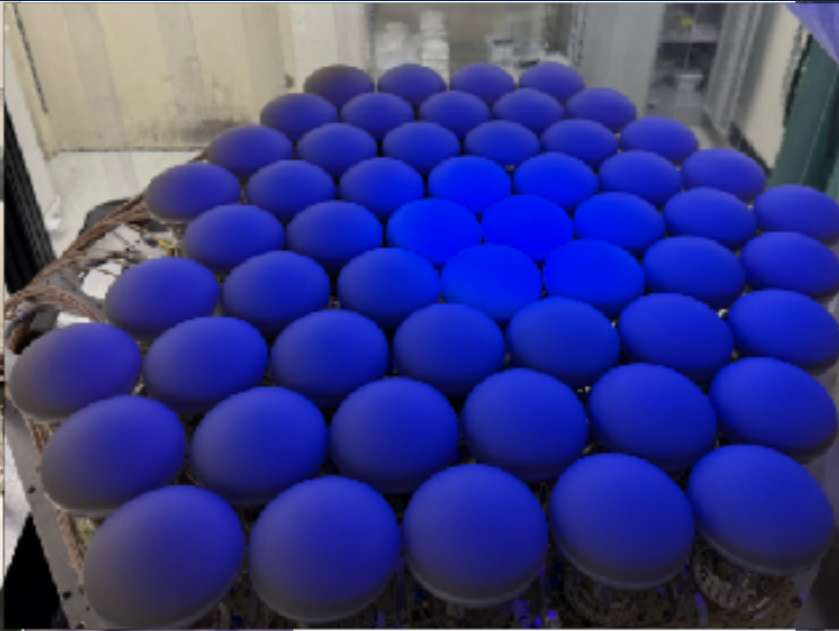

Optical Package team
Oak Ridge National Lab
Seoul National University
Indiana University

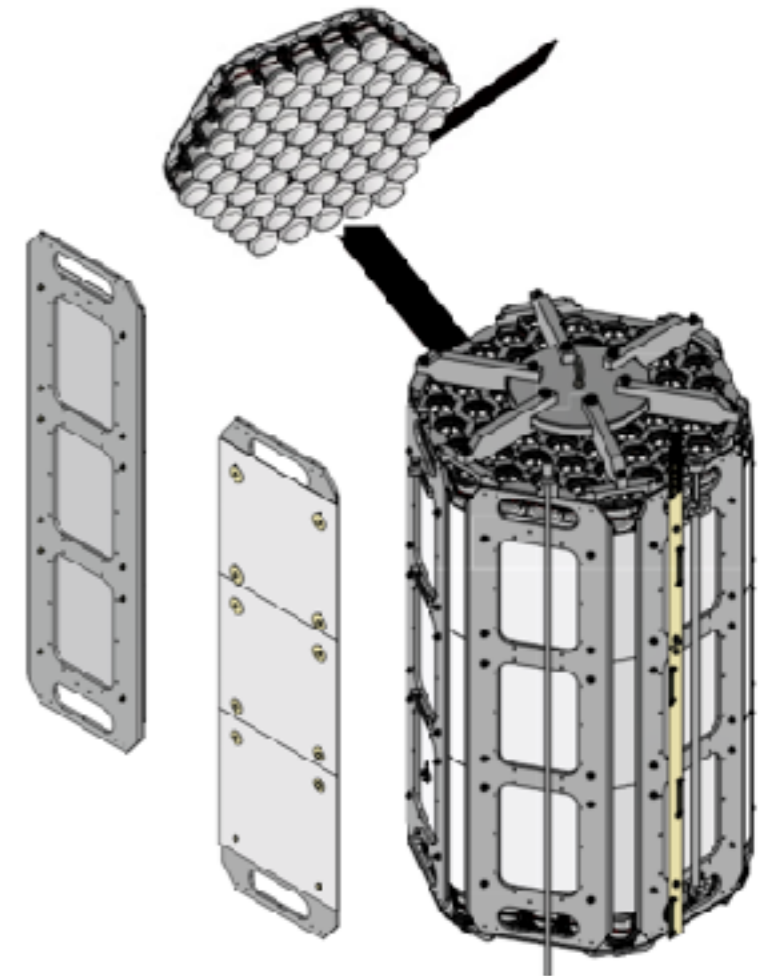
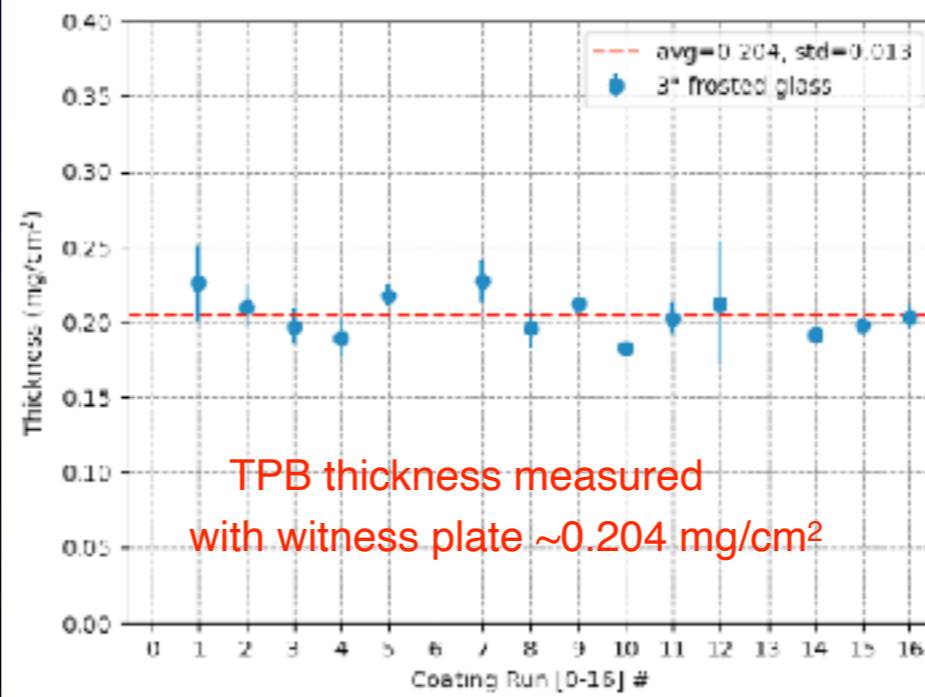

Signal Chain

Signal Chain: PMT/base → PMT Interface box → ADC → DAQ

PMT interface box (122Ch)
Supplies high voltage to the PMTs.
and transmits their signals to the PC

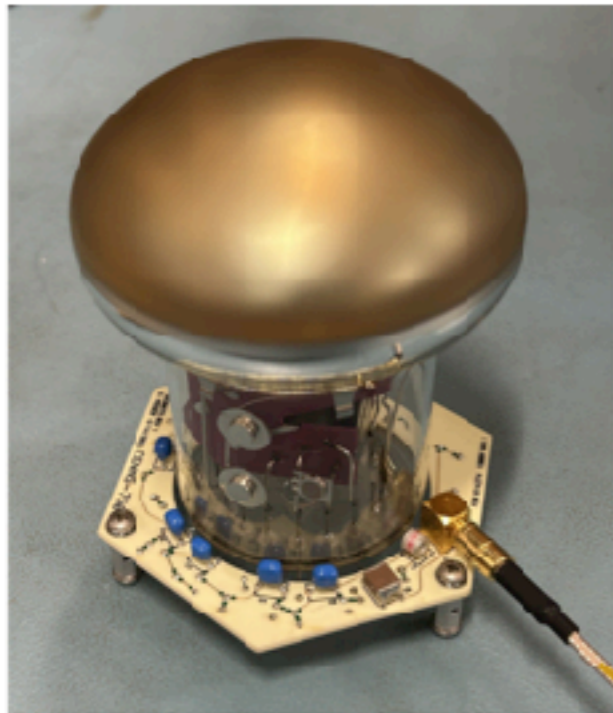

PMT @ 2 – 3E6 gain,
grounded photocathode,
AC coupled (HV+signal on single cable)

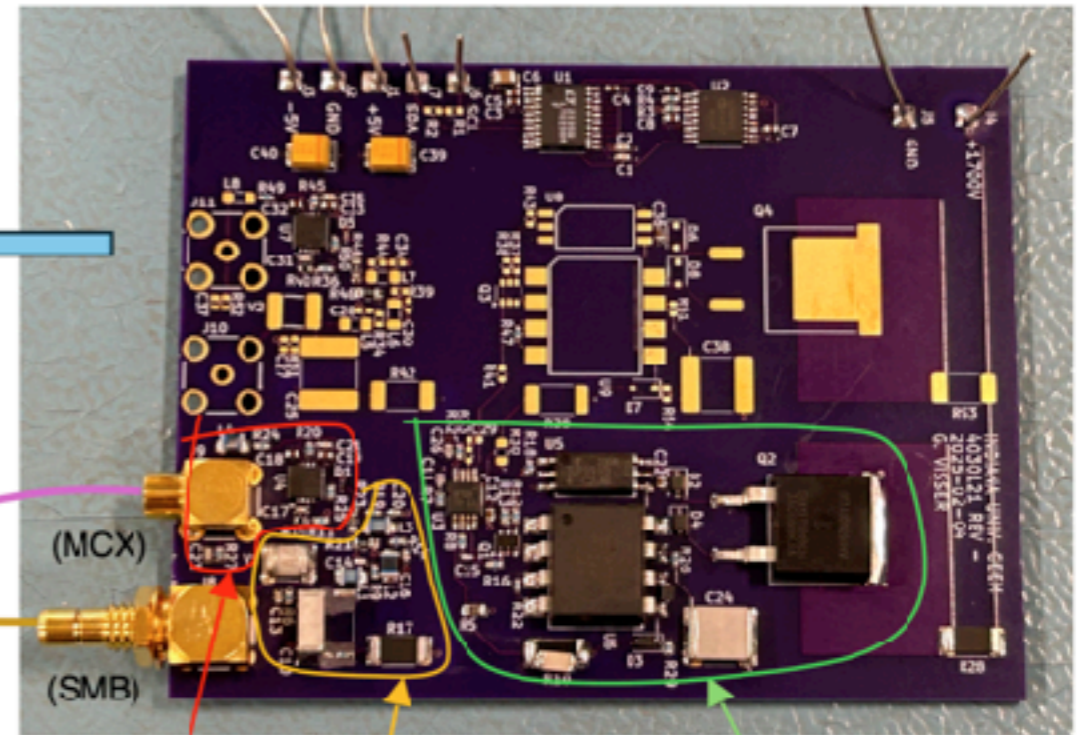
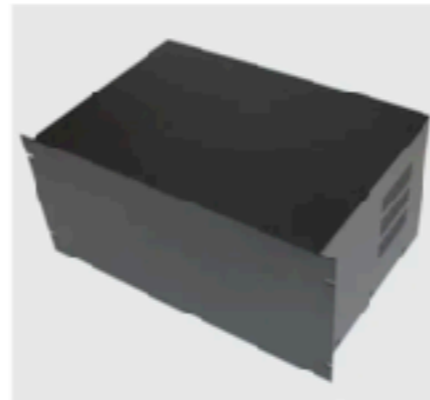

amplifier
50 Ω in/out
G = 4

HV regulator

“splitter”,
shaper (~16 ns peaking time),
and spark protection

122 PMT signals



timing, veto, &c.

2x CAEN VX2740 ADC's
128 ch (total), 16 bit 125 MS/s

DAQ

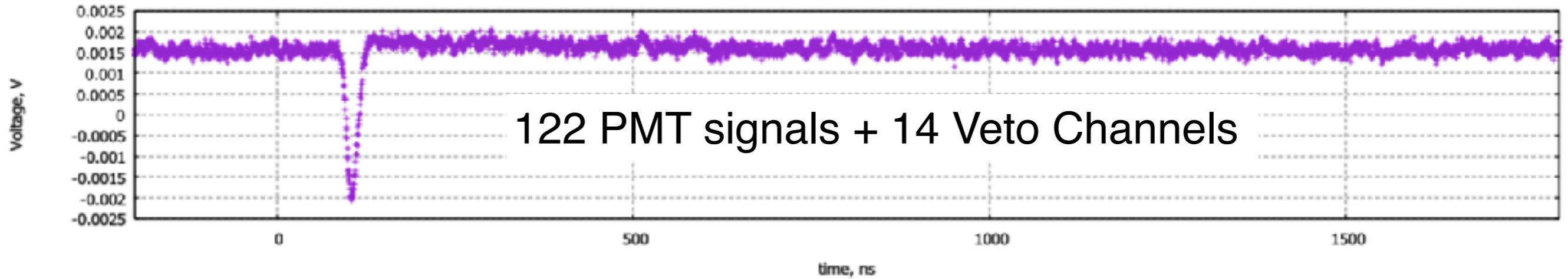

Workflow

- Raw data → InfluxDB → Grafana
(including slow control parameters)
- InfluxDB: Data storage
- Grafana: Data visualization via InfluxDB
The COHERENT collaboration integrates detector monitoring in Grafana

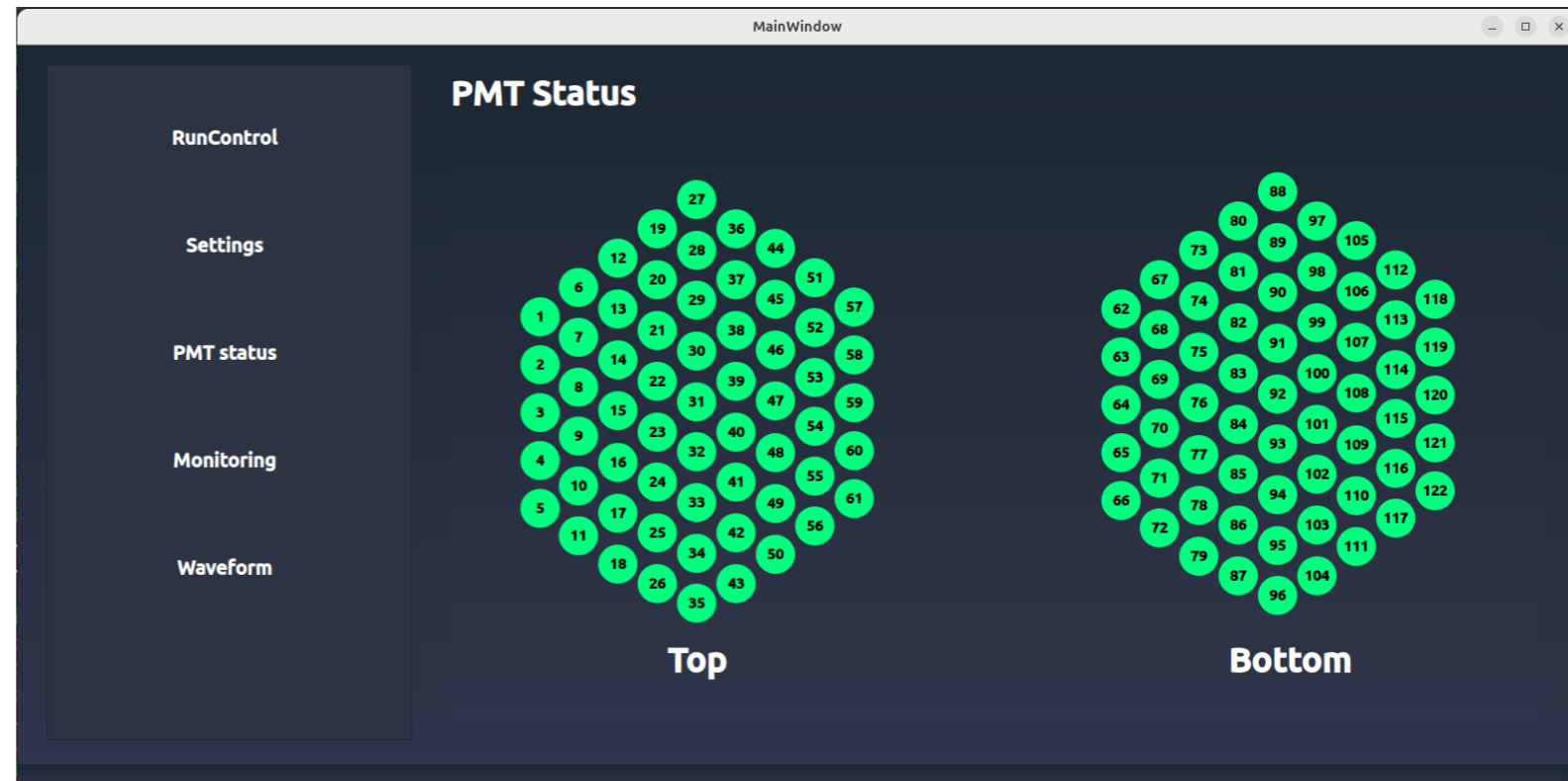

influxdb



Grafana

Veto System

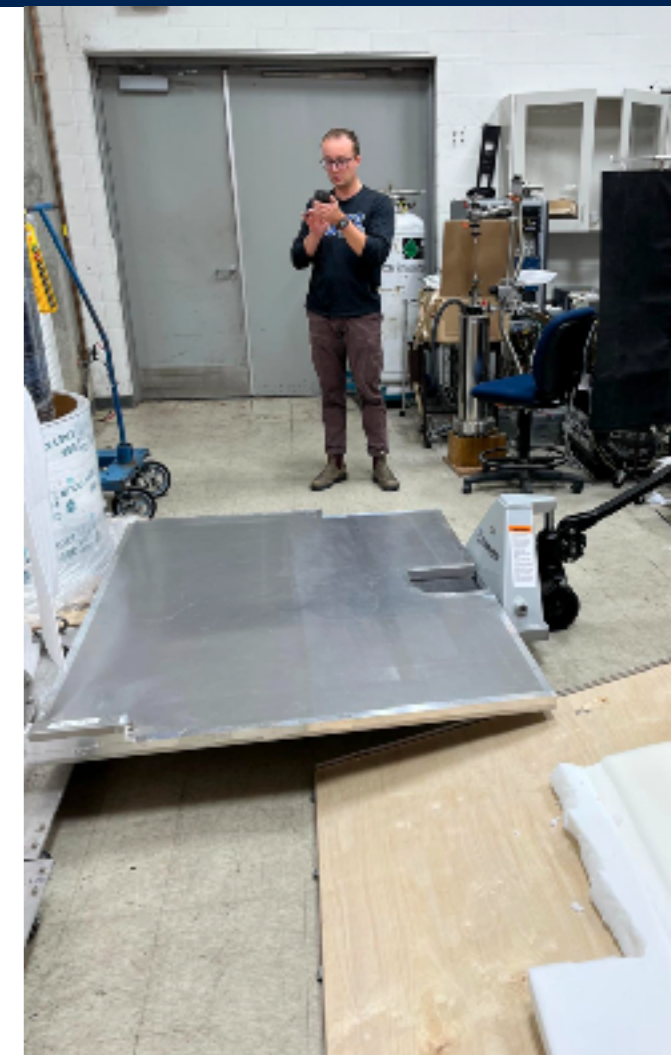
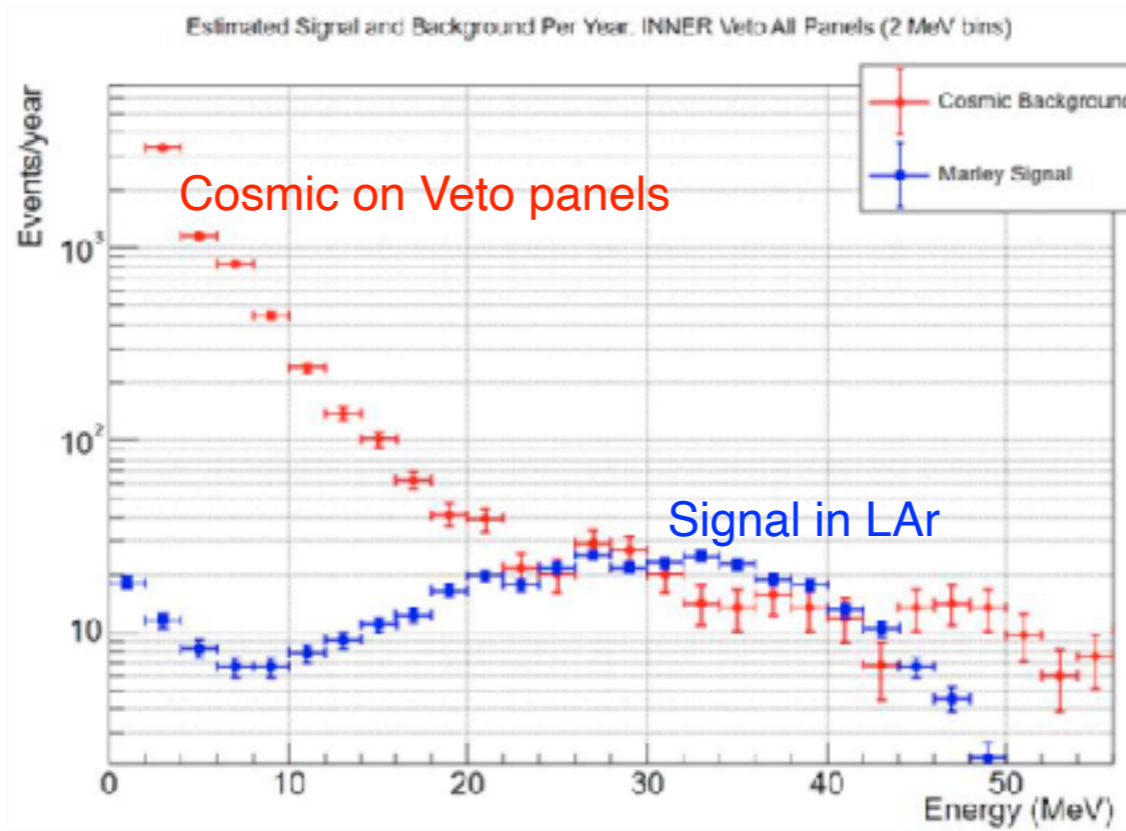
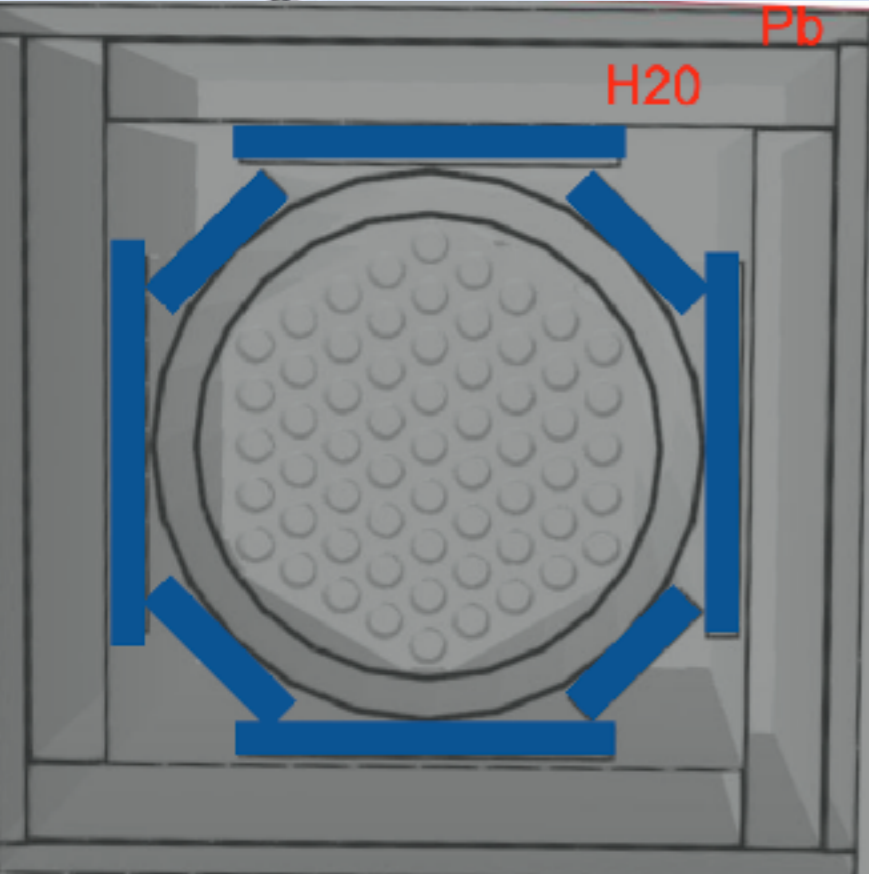
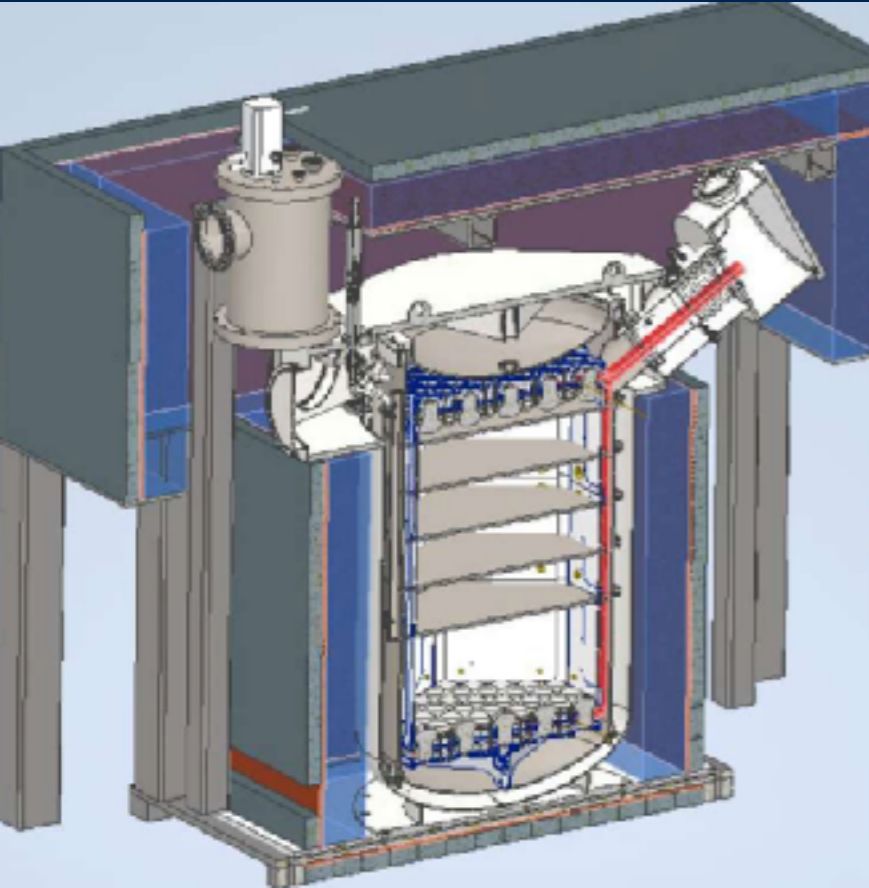

Shielding and Veto

From outside toward the cryostat: **Pb – Water – Scintillator veto panel**

Pb: 2" thick chevron-block walls (gamma shielding)

Water wall: polyethylene tank filled with deionized water (BRN shielding)

Scintillator: Eight 2" thick scintillator veto panels at the side wall

Segmented panels at the bottom of the detector

(active shielding of cosmic muon background)

CENNS-1ton in Neutrino Alley

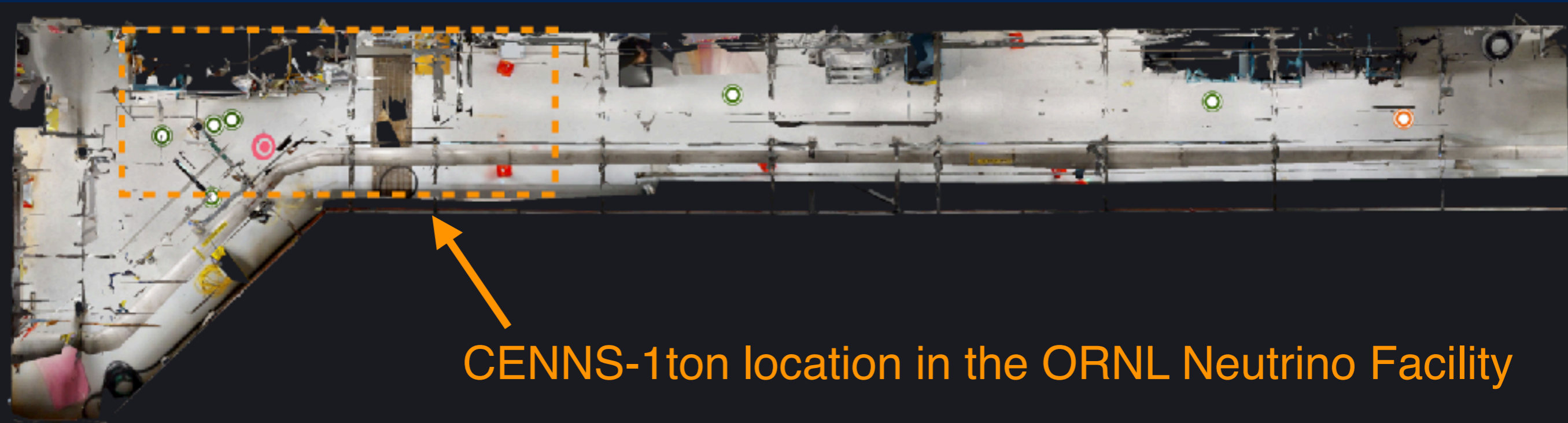

CENNS-1ton location in the ORNL Neutrino Facility

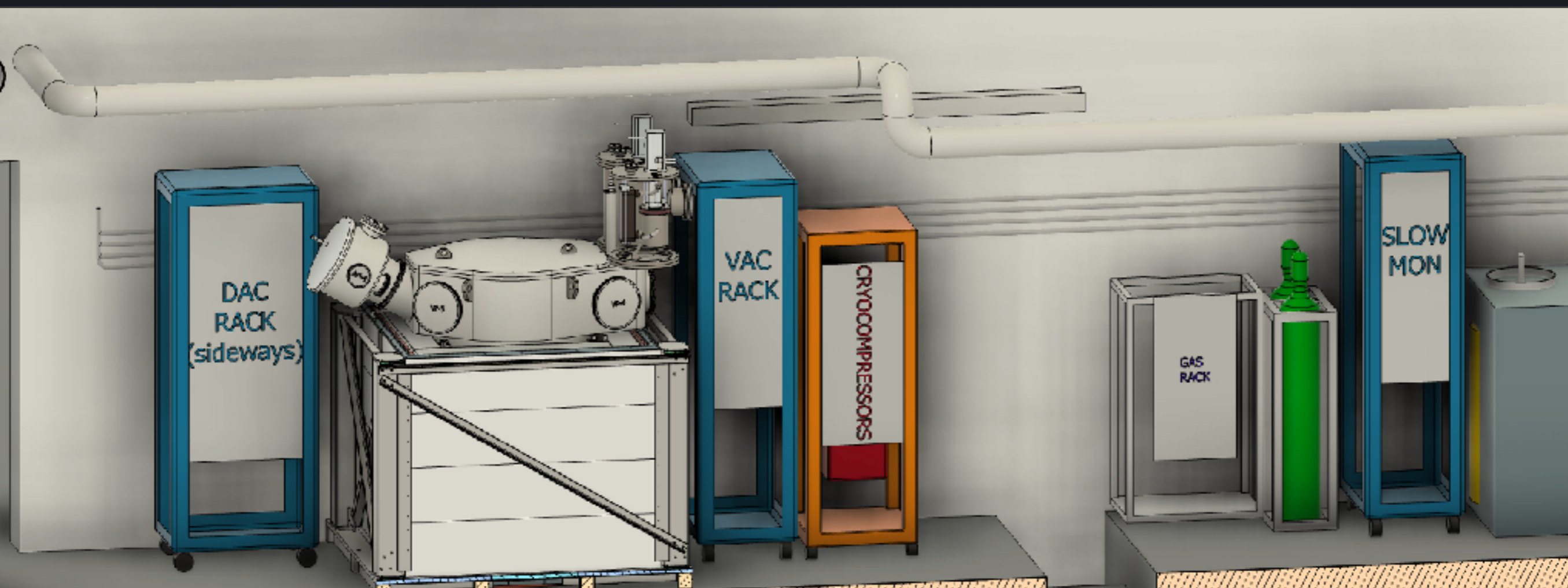

Future CEvNS



**First SNS Target Station
(1.4MW)**

**Second SNS Target Station
Neutrino Research Hall
Total Beam Power 2.8 MW**

• CENNS-1ton → CENNS-10ton (2030?)



2nd Target Station

FTS	2021	2022	2024	2028 STS Neutrino Hall
	1.4 MW	1.7 MW	2.0 MW	FTS: 2.0 MW @ 45 Hz STS: 0.7 MW @ 15 Hz

Calorimetry

COHERENT "First Light" Program

- CEvNS with HPGe, NaI
- Heavy Water Flux Normalization of FTS

Ton-Scale Argon Calorimetry

- CEvNS studies
- Dark Matter searches
- quark-lepton couplings for ν mass ordering
- Low Threshold Detector R&D
- Supernovae neutrino cross sections

- **2000+** users
- Hierarchical materials, time-resolution and small samples

2.8 MW
1.3 GeV
38 mA
60 Hz

FTS
2 MW
45 pulses/sec

STS
0.7 MW
15 Hz

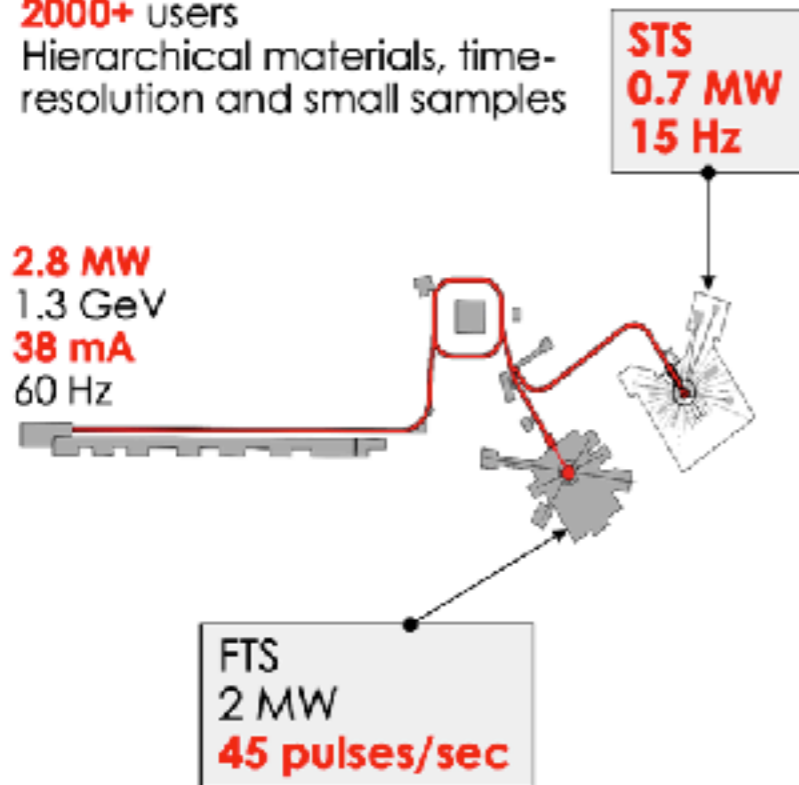

Directionality

Heavy Water Ring Imaging Design

- Improved Flux Normalization
- ν_e -oxygen Interactions for Hyper-K

Argon Detector R&D for STS

- Scalable Low threshold Light Collection
- R&D for Position/Direction Reconstruction
- Direction reconstruction for CC-leptons
- Study for coherent inelastic interactions

Discovery Scale

Neutrino Program at 2nd Target Station

10-ton Liquid Argon

- Beam induced dark Matter searches
- Precision CEvNS studies
- Precision Ar cross sections measurement
- Weak Mixing Angle
- Neutrino EM properties

Heavy Water Ring Imaging

- Flux Normalization of STS
- Precision ν_e -oxygen for Hyper-K



SNS 2nd Target Station (2026.02.06)



Sterile Neutrino Search

- **CEvNS** is a Neutral Current — all active flavor neutrinos interact
 → No active flavor oscillation effect — **Direct search for Sterile Neutrino effect**

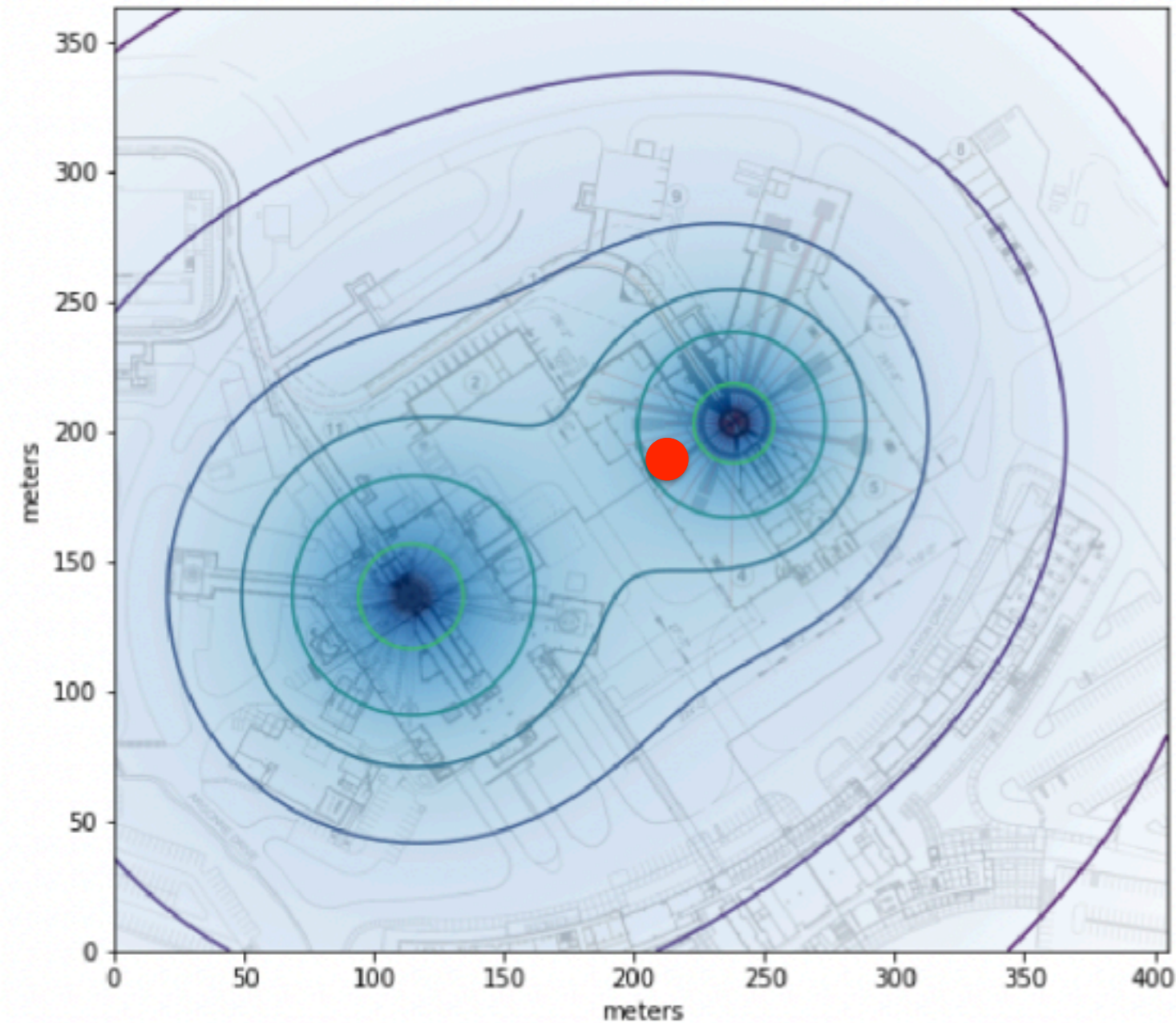

$$P(\nu_e \rightarrow \nu_s) = \sin^2 2\theta_{14} \cos^2 \theta_{24} \cos^2 \theta_{34} \sin^2 \left(\frac{\Delta m_{41}^2 L}{4E} \right)$$

$$P(\nu_\mu \rightarrow \nu_s) = \cos^2 \theta_{14} \sin^2 2\theta_{24} \cos^2 \theta_{34} \sin^2 \left(\frac{\Delta m_{41}^2 L}{4E} \right)$$

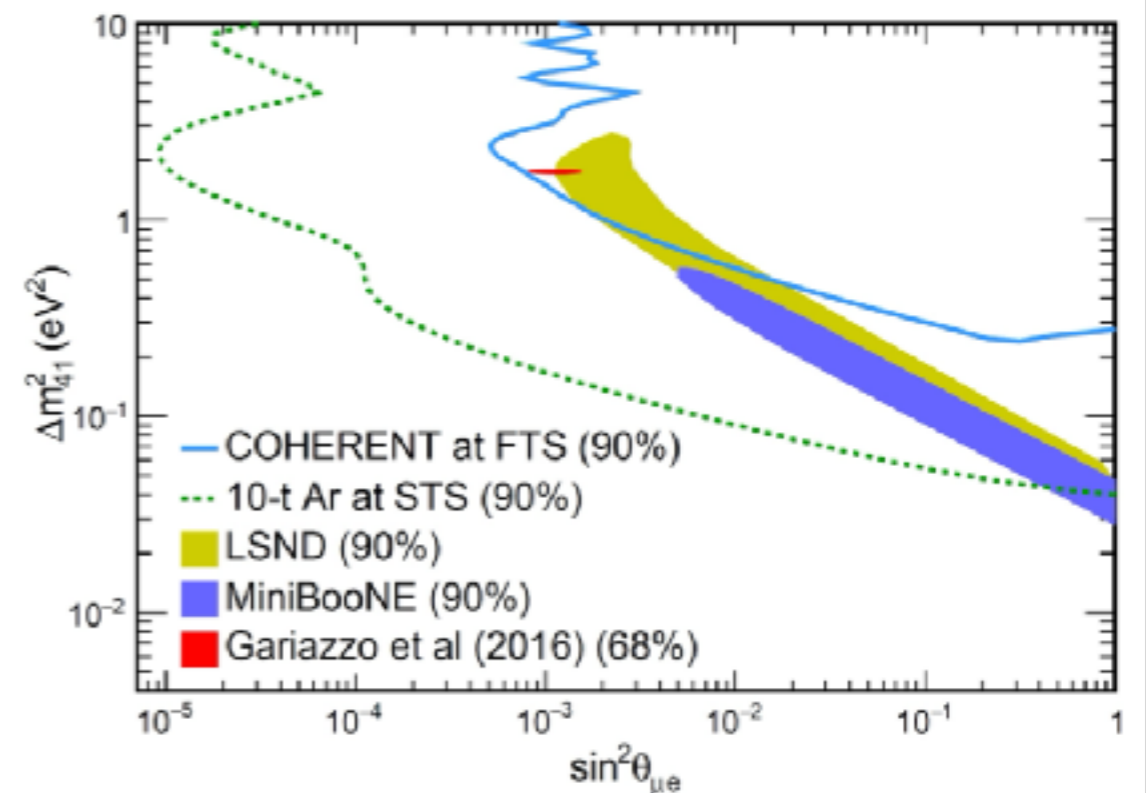

Weak Mixing Angle

- Weinberg Angle ($\sin^2\theta_W = 0.231$) has measured in Z-resonance
 → θ_W is a free parameter in SM (huge uncertainty in low E)

$$\sigma_{tot} = \frac{G_F^2 E_\nu^2}{4\pi} \left[Z(1 - 4\sin^2\theta_W) - N \right]^2 F^2(Q^2)$$

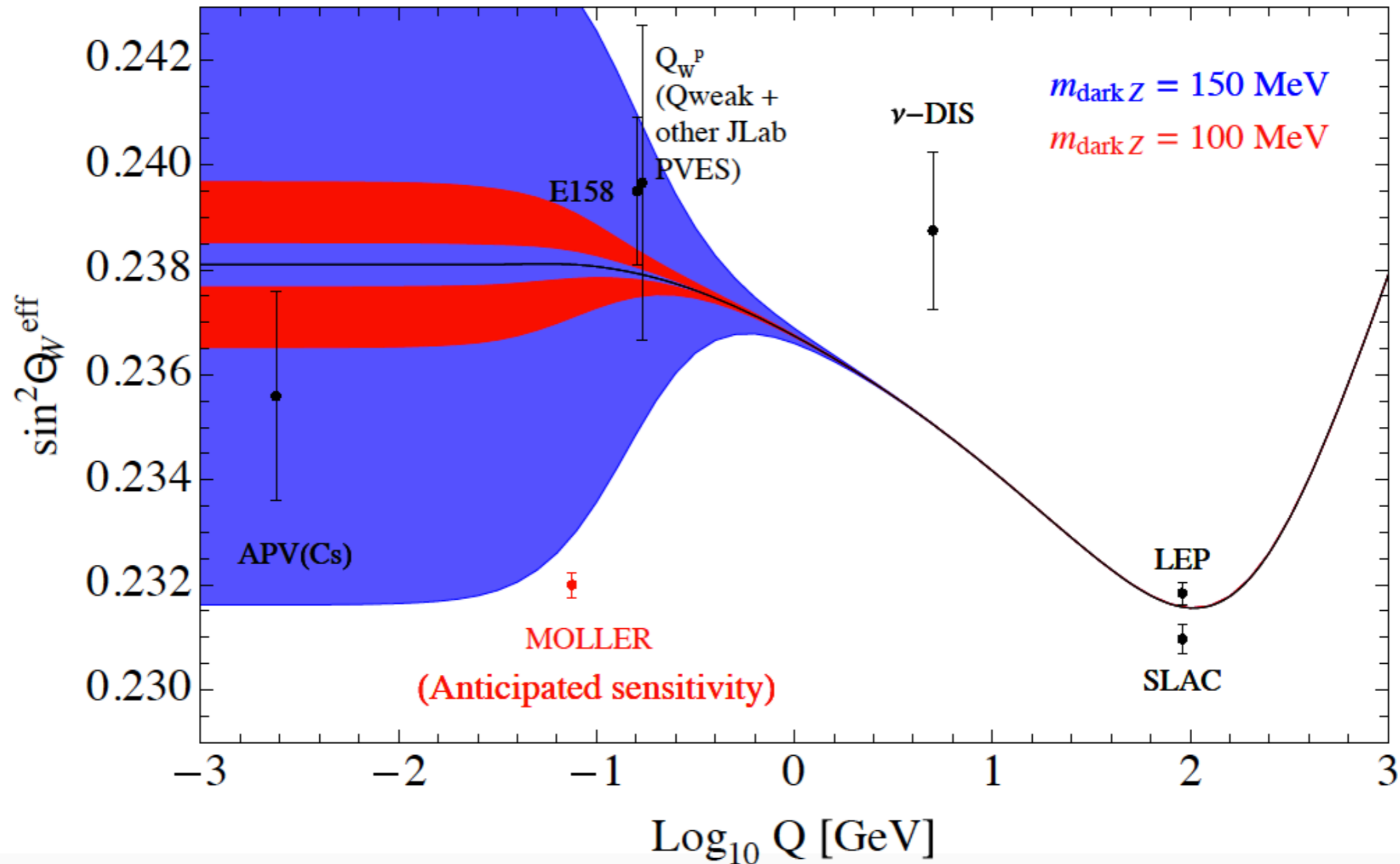

Future CEvNS: Supernova Neutrinos

Large effect on Supernovae dynamics.

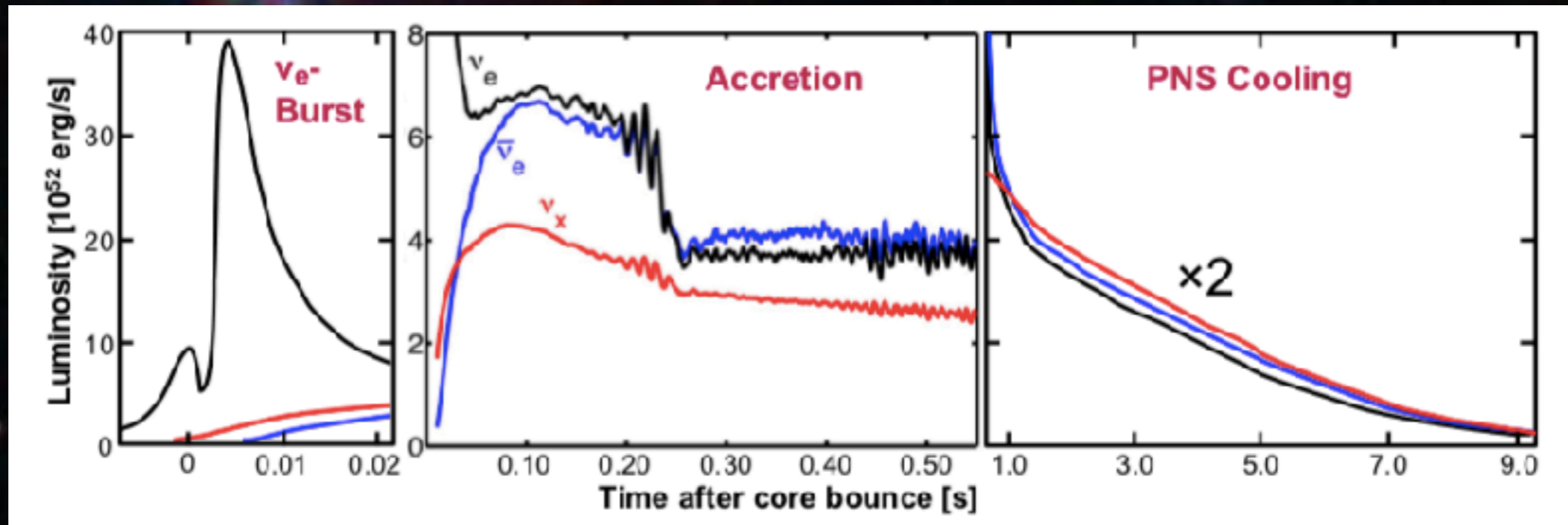



Detector R&D at Seoul National University

For the next generation

Detector R&D @SNU

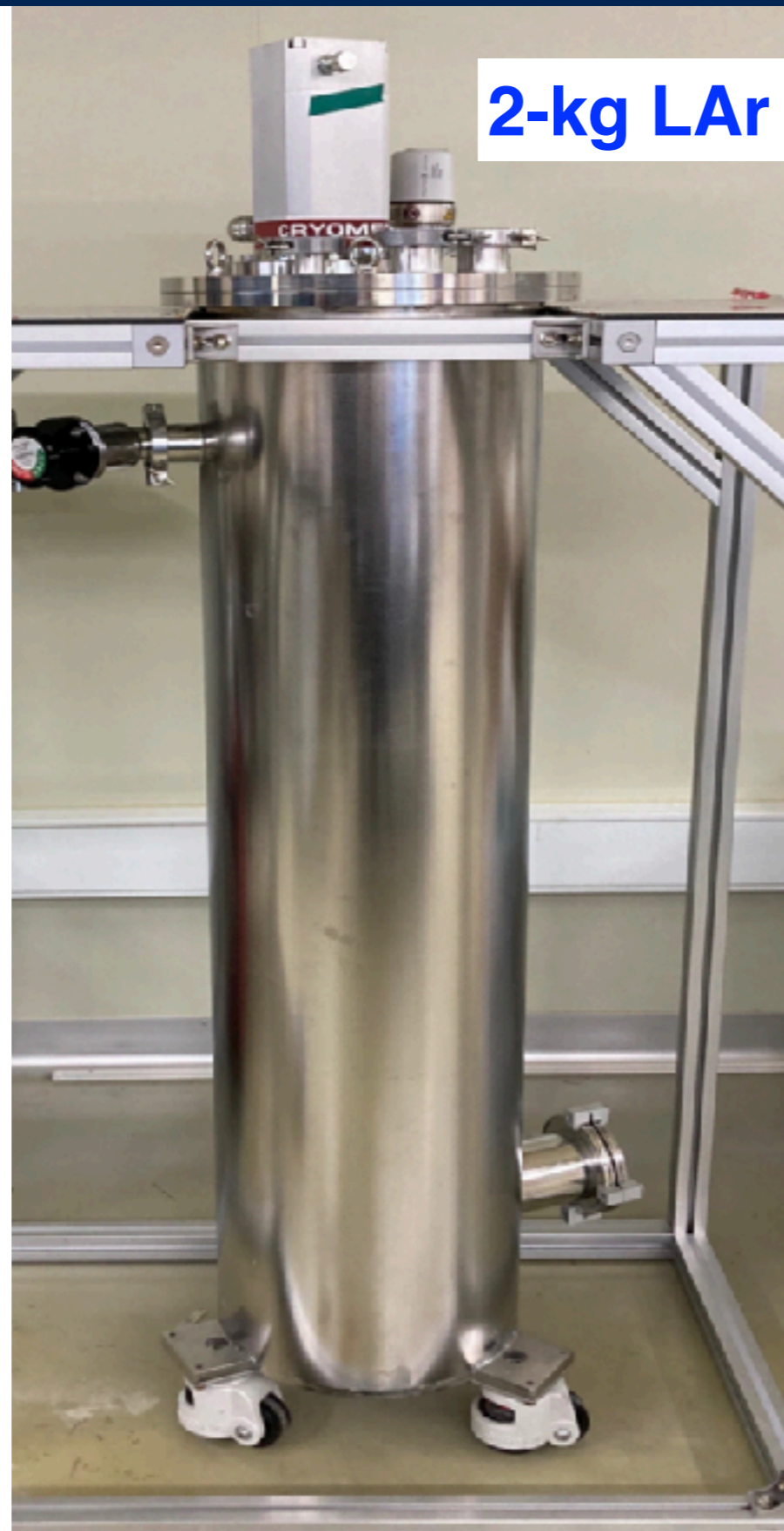
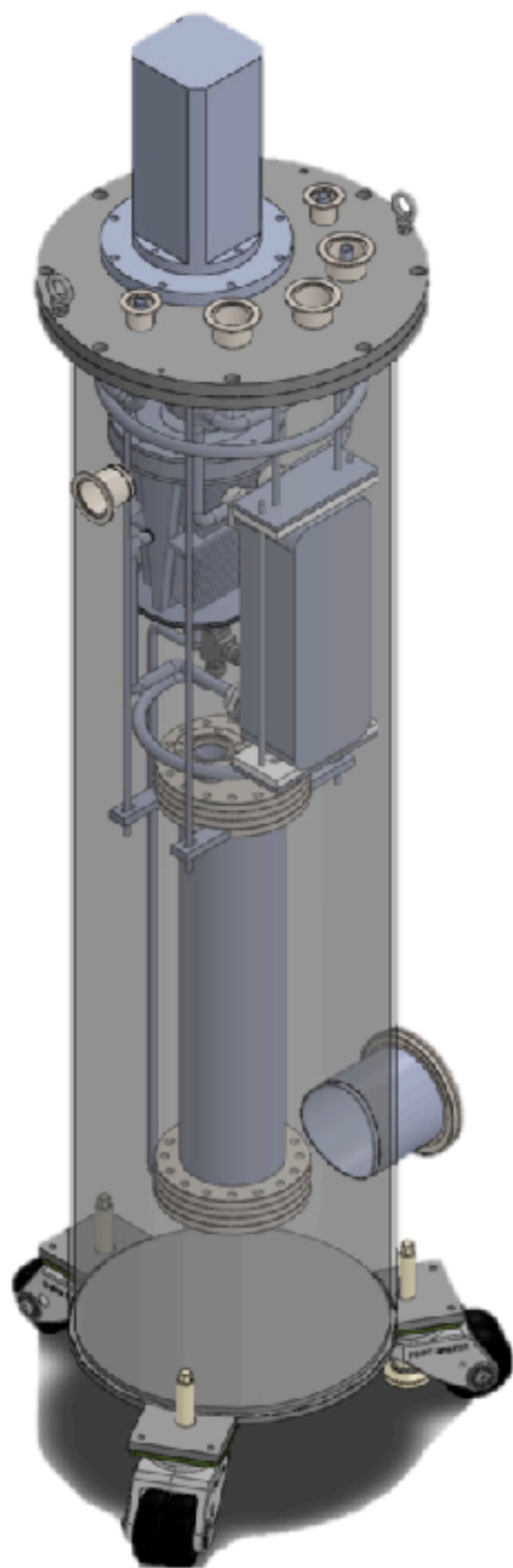

2-kg LAr test chamber

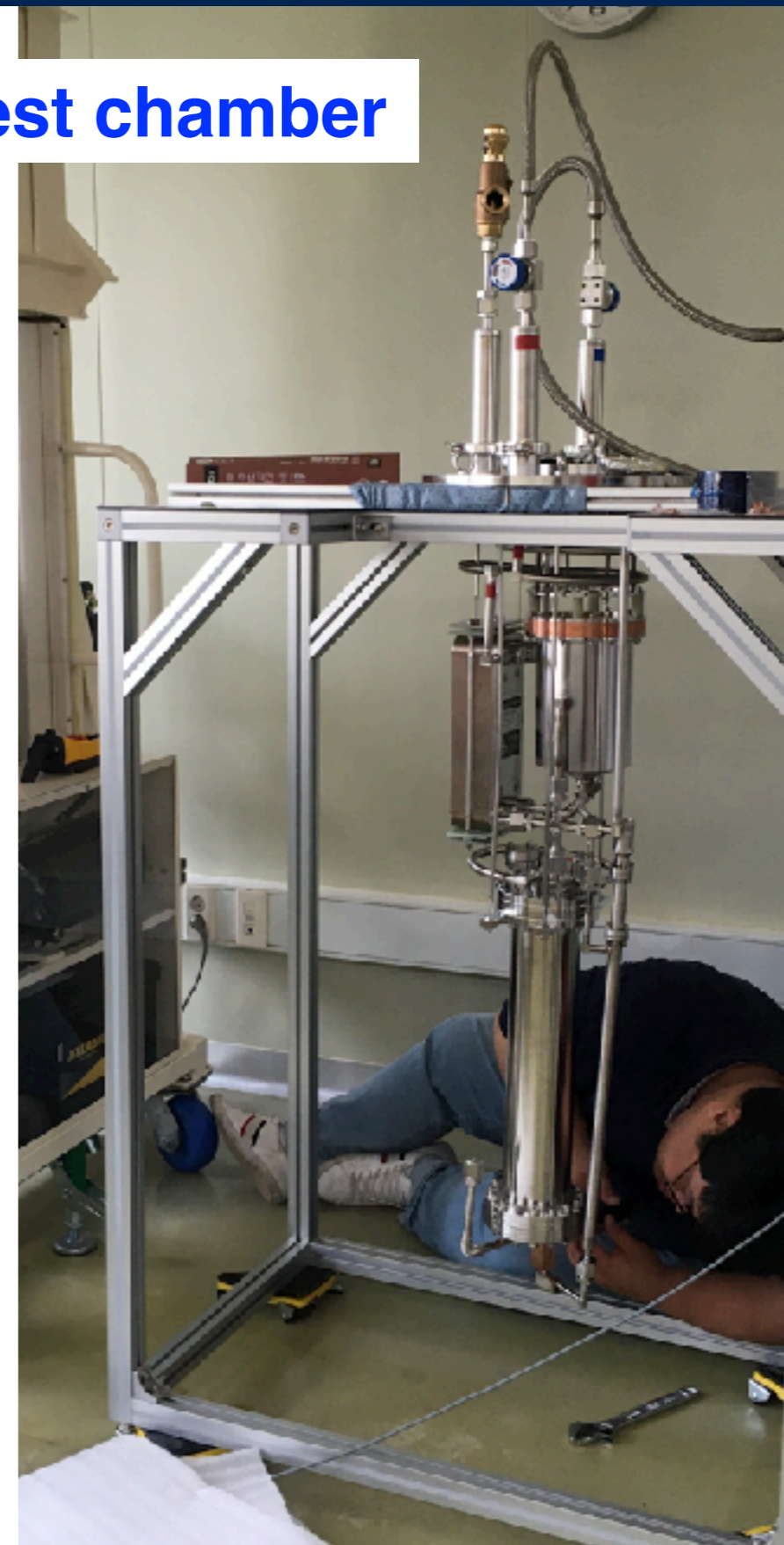

Detector R&D @SNU

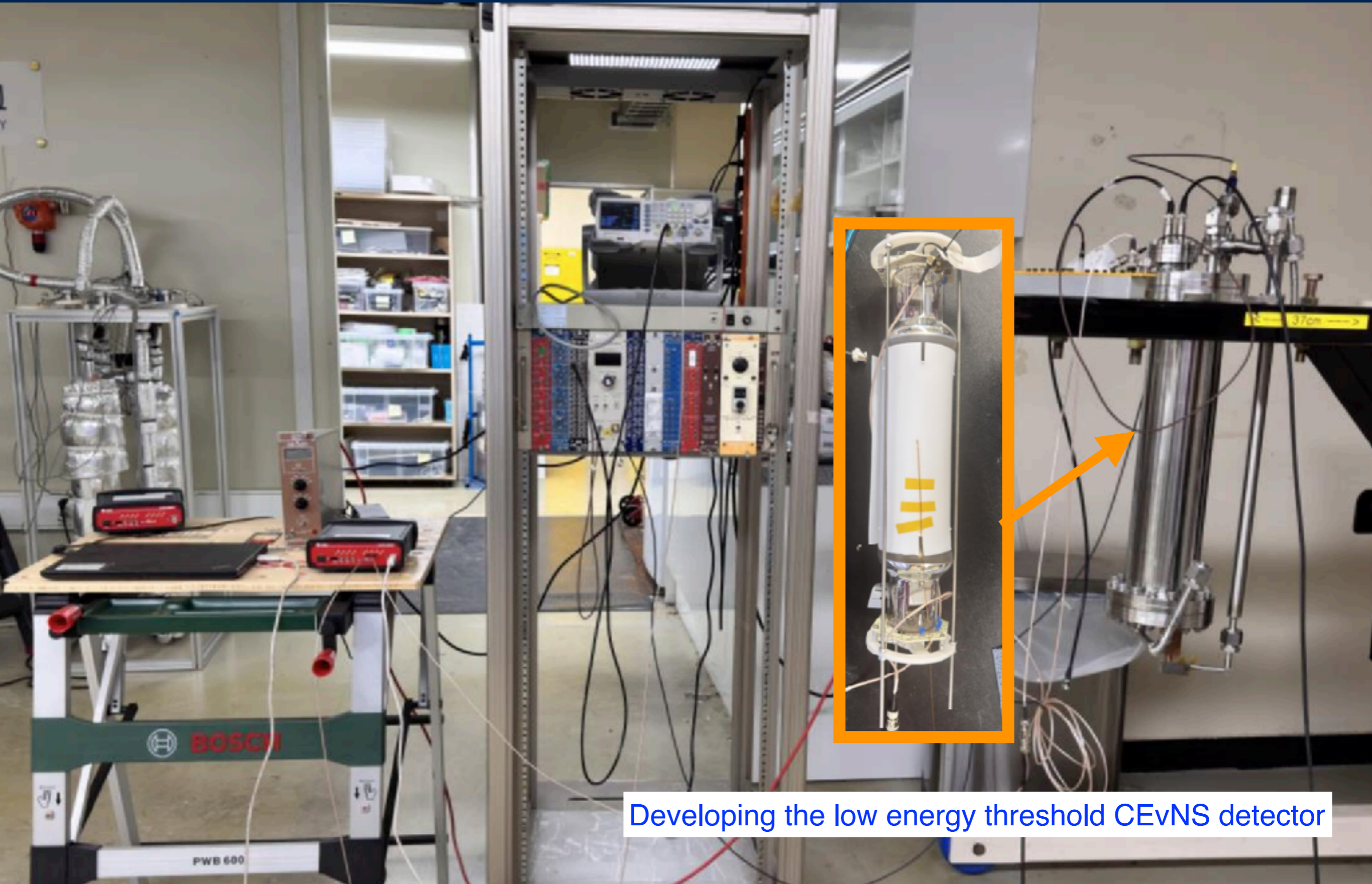

Developing the low energy threshold CEvNS detector

Detector R&D @SNU

Liquid phase purification system:

- H₂O filter: Molecular Sieves
- O₂ filter: Activated-copper-coated granules
- GM cooler with purity monitor (need liquid phase circulation)
- Perfect testbed for LArTPC

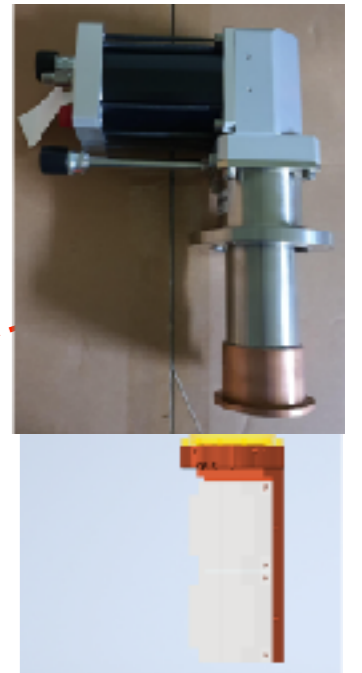
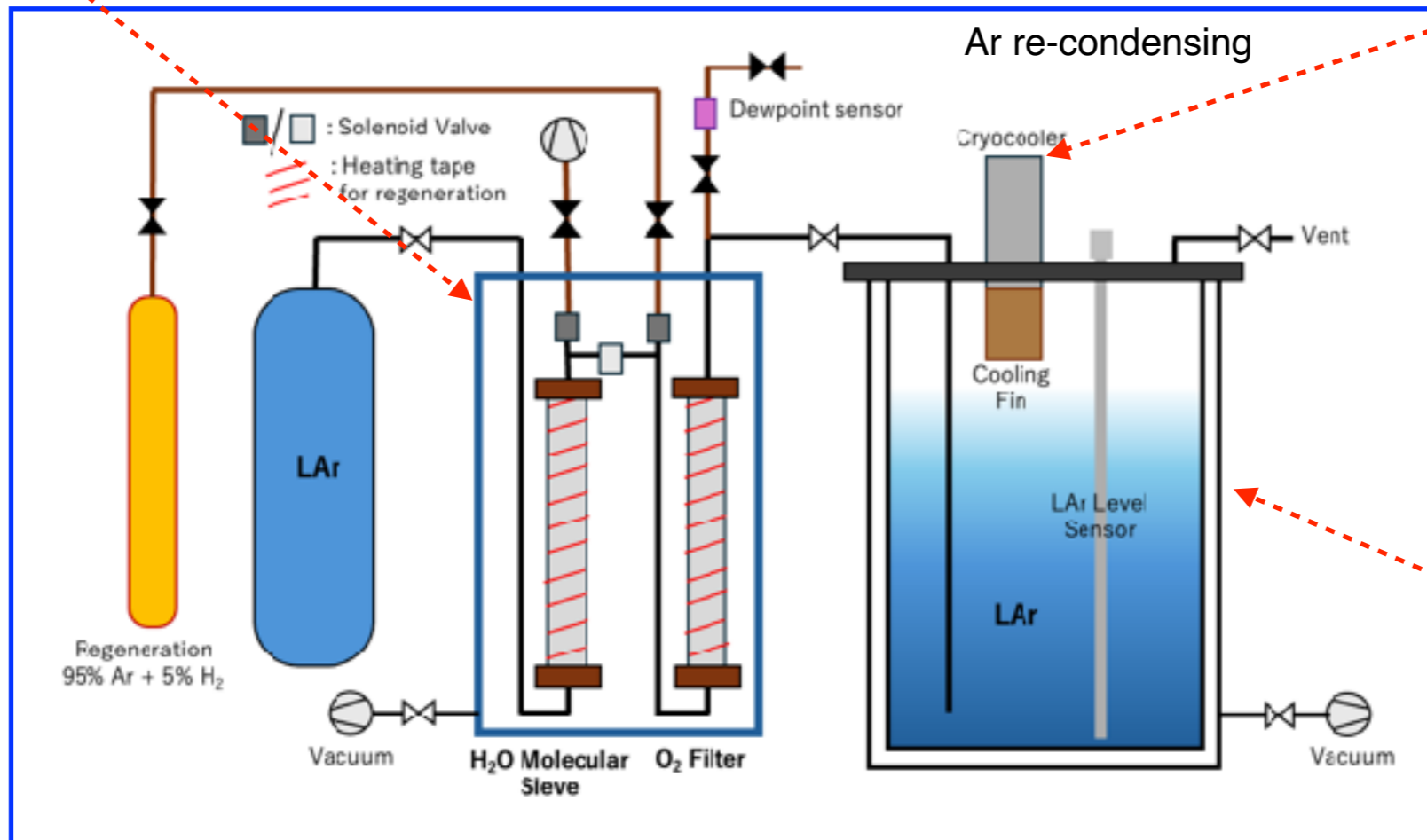

Heating tape



Molecular Sieve



Copper-coated granules

Summary & Plan



- **CENNS-10 observed CEvNS in 2020, with 30% uncertainty**
 - Run2 data (x2 exposure) analysis will be reported soon
- **CENNS-1ton detector is fabricated, assembled, and tested at SNU**
 - Detector chamber delivered to ORNL
 - TPB coating for the Optical Package has been completed
 - Expect data taking in 2026
- **CENNS-1ton will achieve uncertainty of 5% in 3 years**
 - Expect 4400 CEvNS / year (+DM search, NSI, neutron radius, ...)
- **Detector R&D focused on LArTPC will be continued at SNU**

COHERENT Collaboration

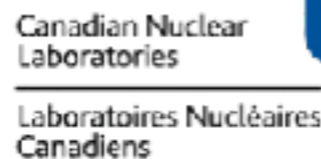

National Research Foundation of Korea