



Northwestern
University



Particle impact energy reconstruction using transmons

Emanuela Celi on behalf of CosmiQuantum group

RISQ 2026

June 18th 2026

Analysis goals

1. Validate the Quasiparticle density model through a fit on the experimental data
2. Reconstruct energy deposited in individual qubits and in the substrate

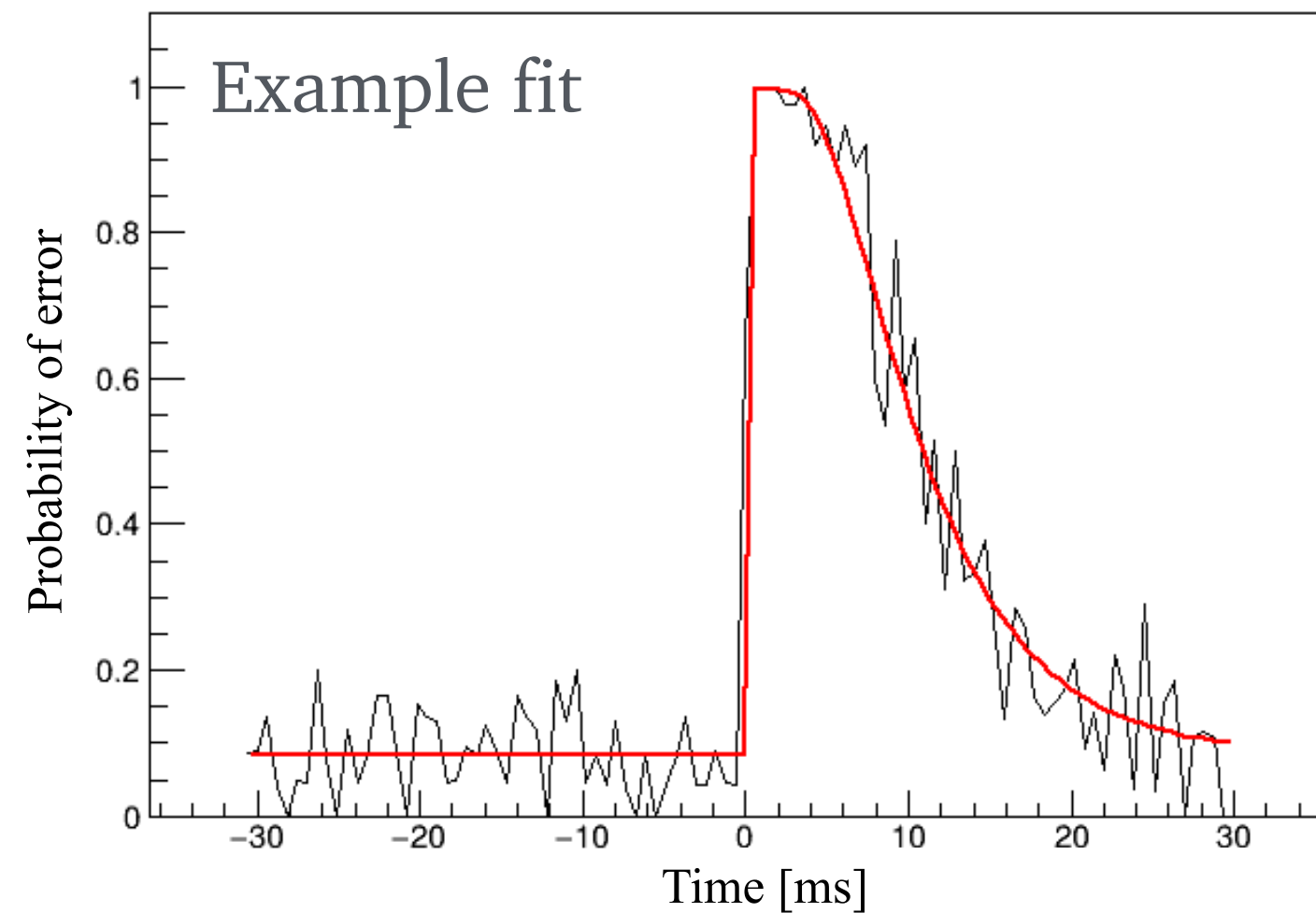
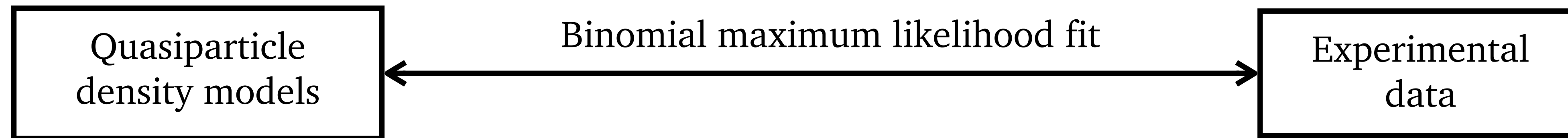
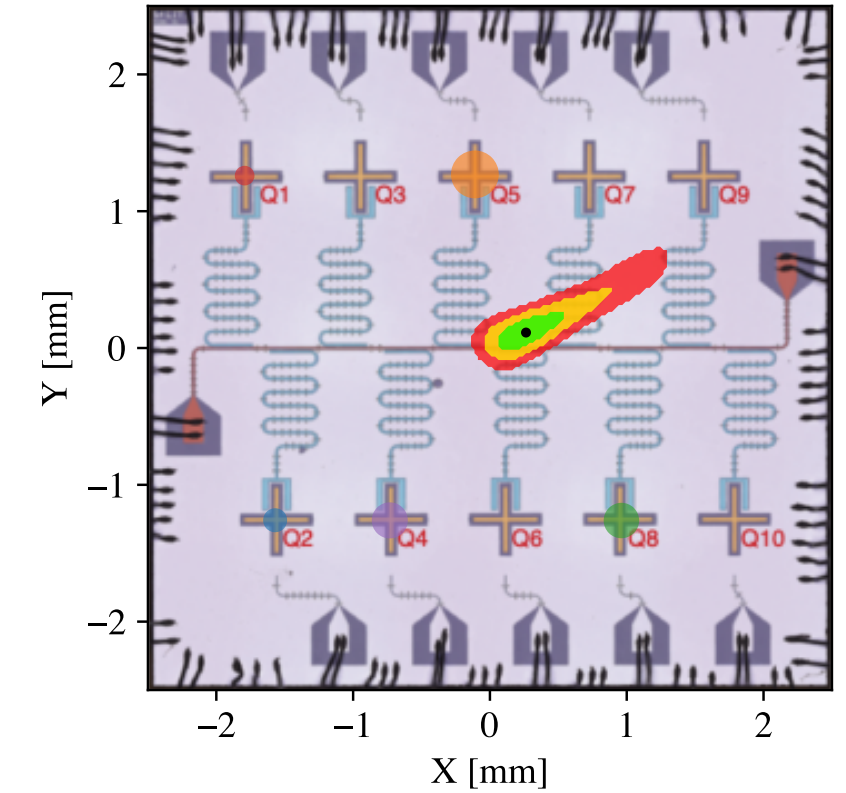

Measuring quasiparticle dynamics for particle impact reconstruction in a superconducting qubit chip

E. Celi,^{1,*} R. Linehan,² P. M. Harrington,³ M. Li,³ H. D. Pinckney,³
K. Serniak,⁴ W. D. Oliver,³ J. A. Formaggio,³ E. Figueroa-Feliciano,^{1,2} and D. Baxter^{2,1}

¹Northwestern University, Evanston, IL 60208, USA

²Fermi National Accelerator Laboratory, Batavia, IL 60510, USA

³Massachusetts Institute of Technology, Cambridge, MA 02139, USA

⁴MIT Lincoln Laboratory, Lexington, MA 02421, USA



[Celi et al. \(2026\)](#)



Northwestern University

Experimental data

- ❖ Array of 10 fixed-frequency transmon qubits (Aluminum on Silicon)
- ❖ Coincidences between muon scintillating detectors and correlated errors
- ❖ ~266 hr background data (~10 mHz event rate)
- ❖ ~16 hr ^{137}Cs source data (~100 mHz event rate)
- ❖ Only 5 qubits available for the analysis → slow recovery

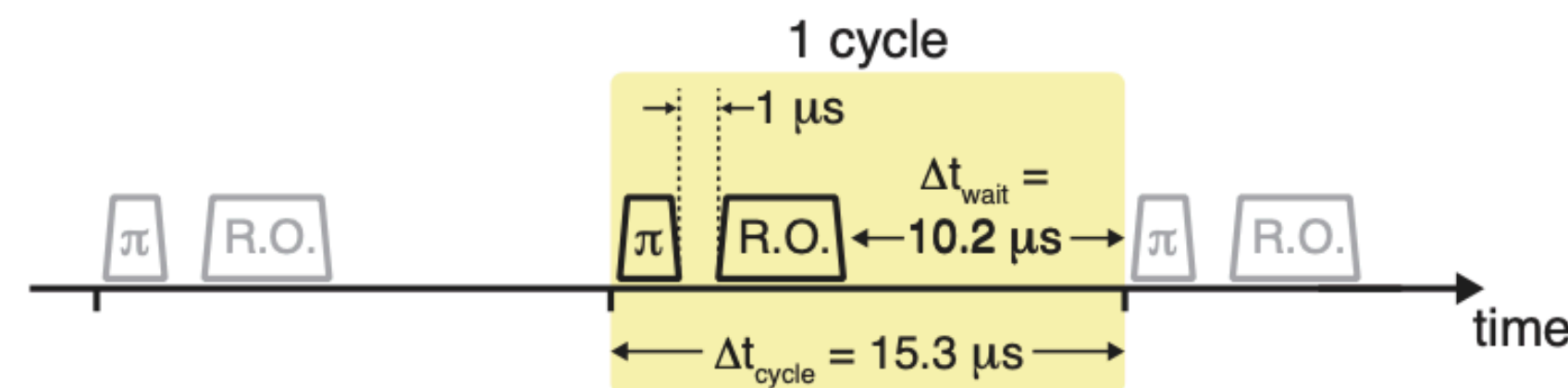
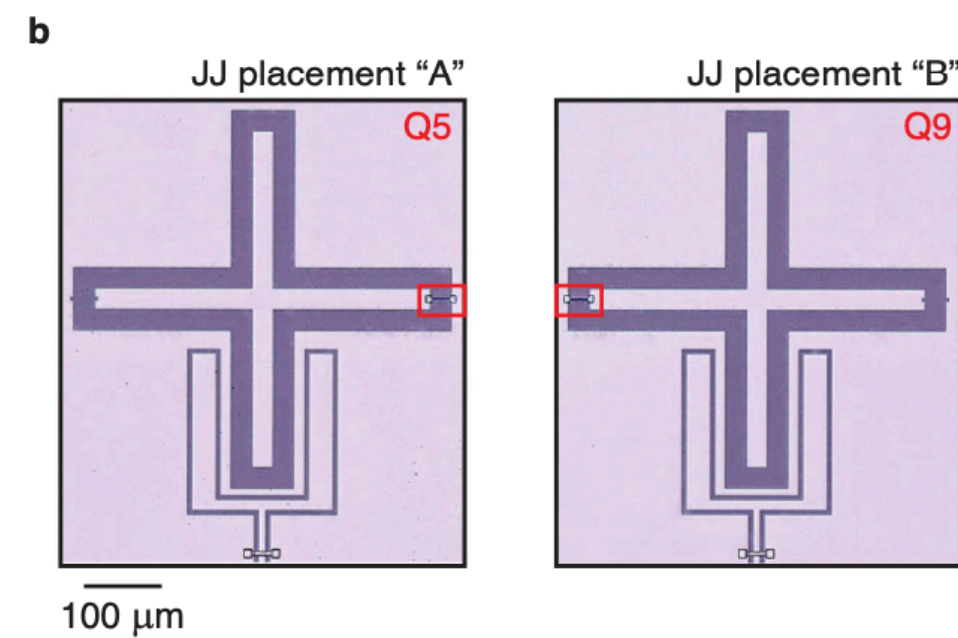
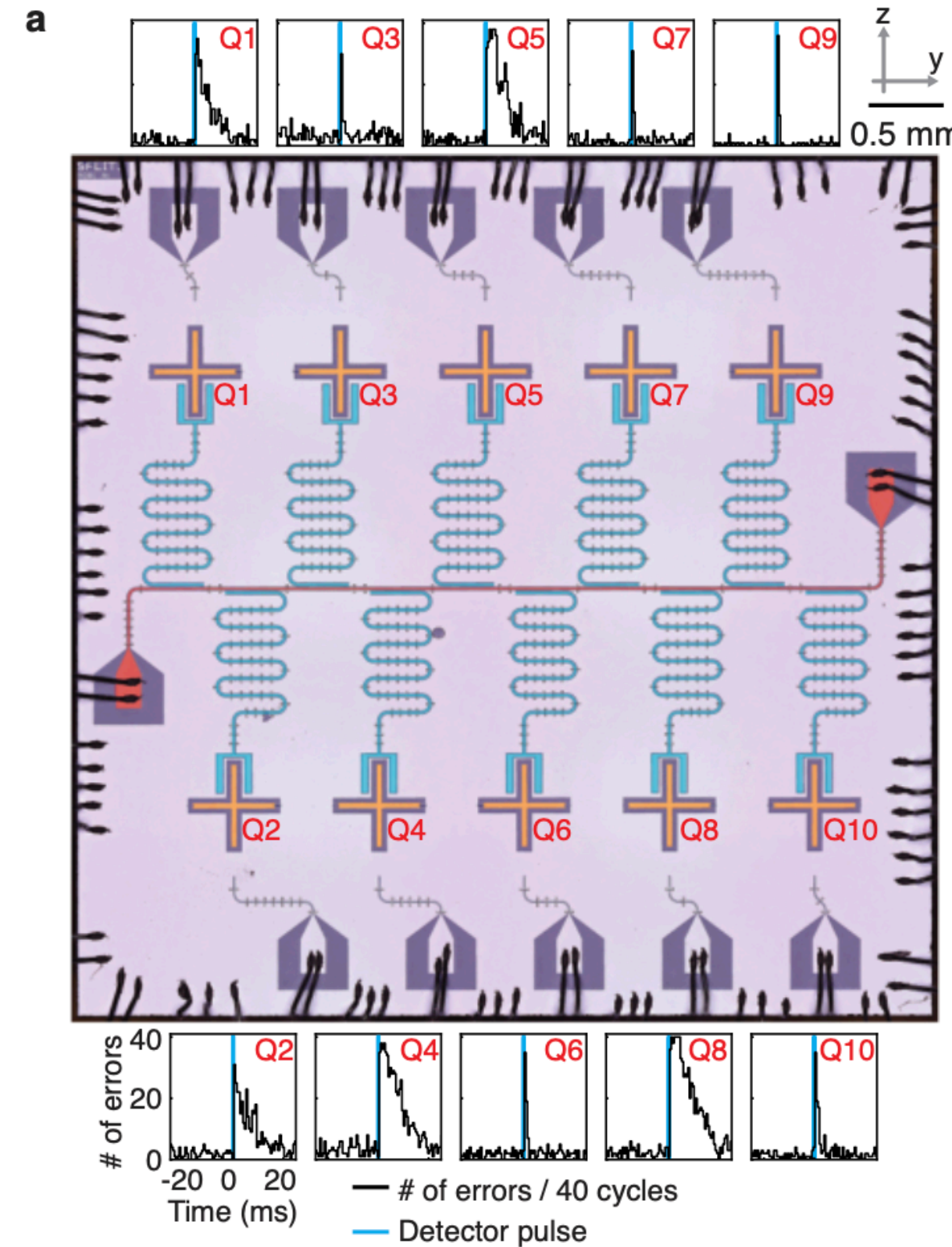

[Harrington et al, \(2024\)](#)

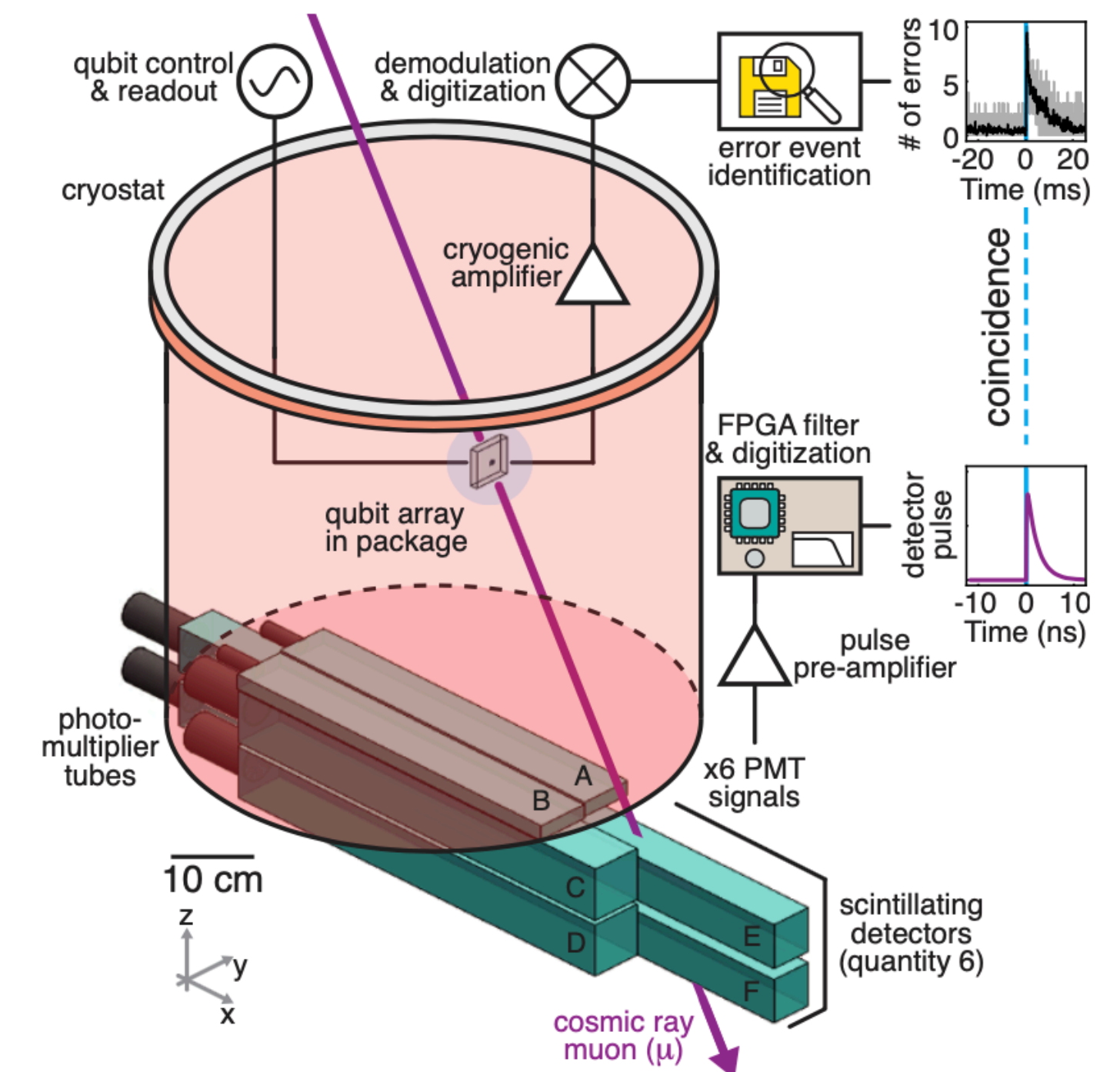

See D. Pinckney's talk

Quasiparticle density model

QP dynamics is dominated by QP self-recombination, linear loss and QP generation mechanisms.

$$\frac{dx_{qp}}{dt} = -rx_{qp}^2 - sx_{qp} + g$$

Recombination rate Trapping rate QP generation

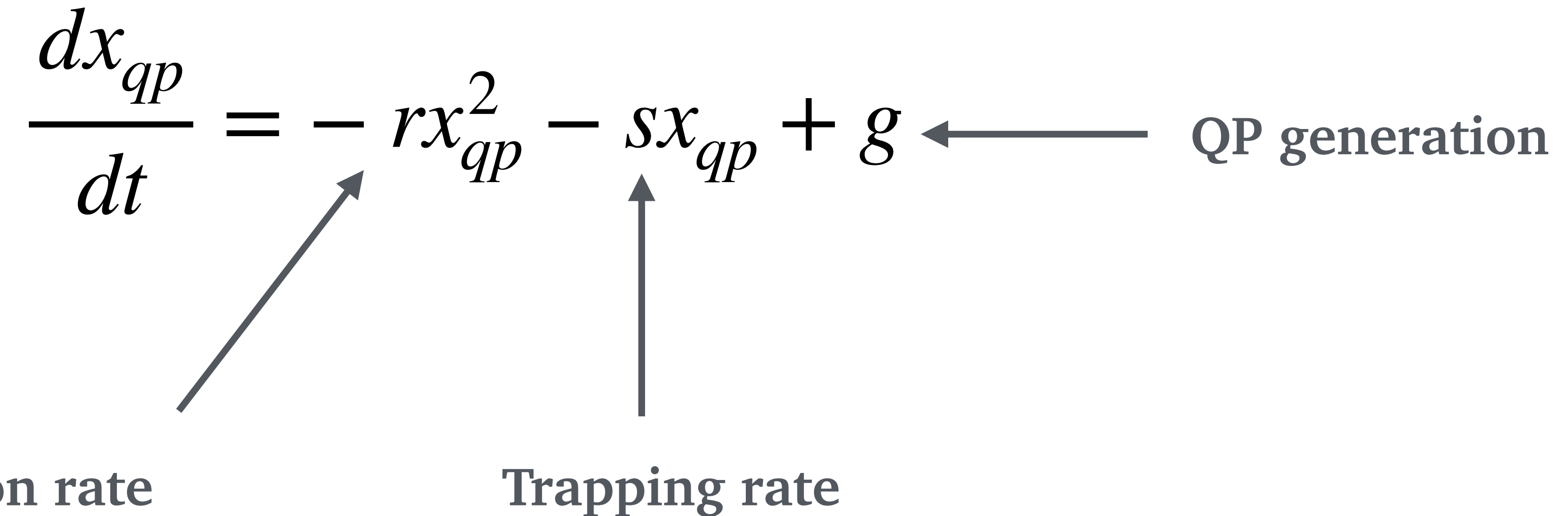

Quasiparticle density model

Parameter	Value	Description
n_{cp}	$4 \times 10^{24} \text{ m}^{-3}$	Cooper Pair density
Δ	$180 \text{ } \mu\text{eV}$	SC energy gap
V	$6975 \text{ } \mu\text{m}^3$	Island volume
ϵ	0.57	Phonon-to-QP efficiency
Δt	$3 \text{ } \mu\text{s}$	Time interval

QP dynamics is dominated by QP self-recombination, linear loss and QP generation mechanisms. Probability of relaxation in a time Δt is:

$$p_r = 1 - e^{-\Gamma(t)\Delta t}$$

$$= 1 - \exp \left[\frac{-\alpha E_{\text{dep}}}{E_{\text{dep}} \left[\tau_{ss} r (e^{t/\tau_{ss}} - 1) \right] + \beta e^{t/\tau_{ss}}} - \gamma \right]$$

r = recombination constant rate

$\tau_{ss} \approx 1/s$ linear loss decay time

E_{dep} = energy deposited in the capacitor

[Linehan et al, \(2024\)](#)

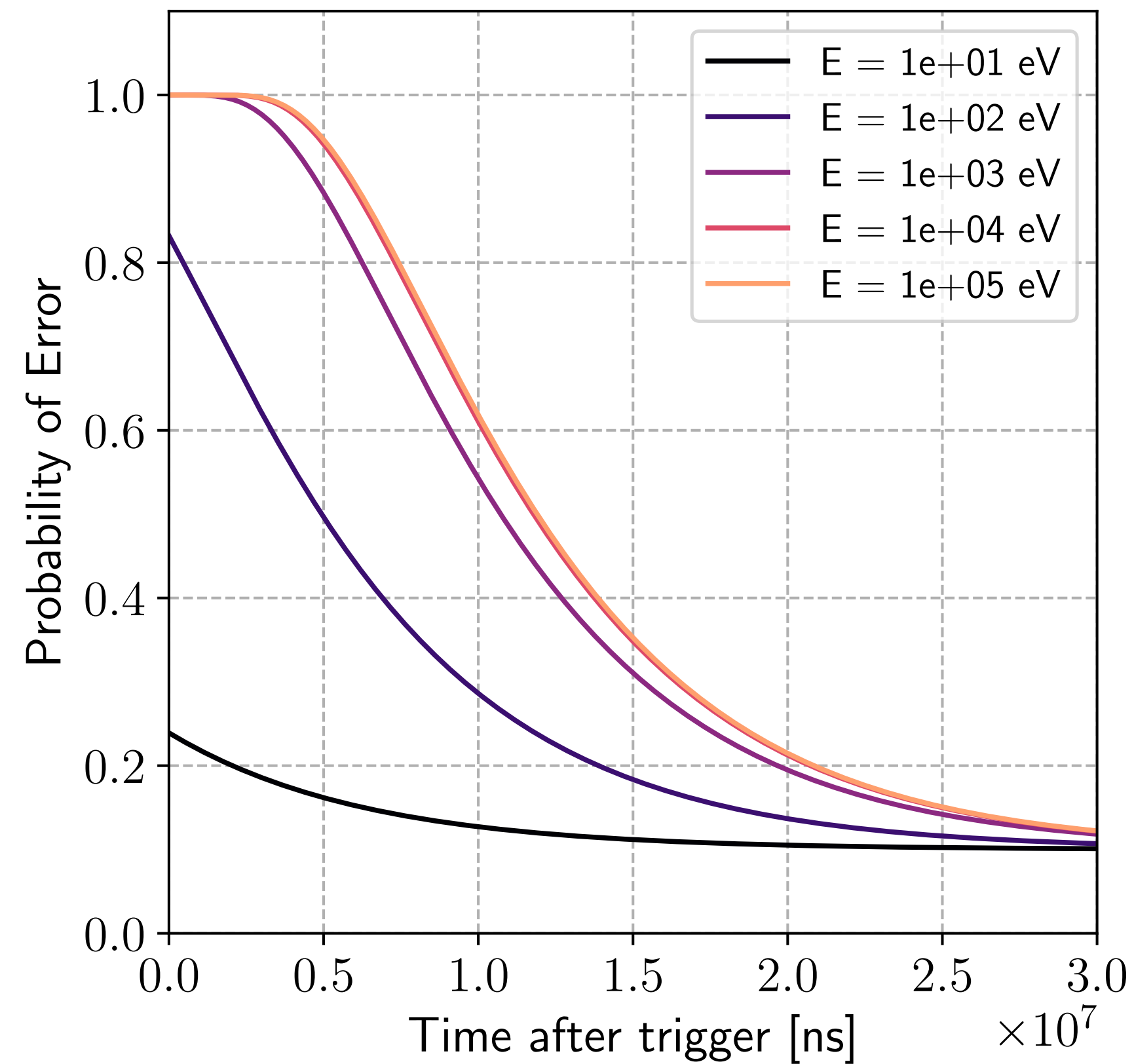

Constants:

$$\alpha = \Delta t \sqrt{\frac{2\omega_q \Delta}{\pi^2 \hbar}}$$

$$\beta = \frac{n_{CP} V \Delta}{\epsilon}$$

Other variables:

$$\gamma = \frac{\Delta t}{T_1} \rightarrow \text{other relaxation mechanism or steady-state QP density}$$

Analysis workflow

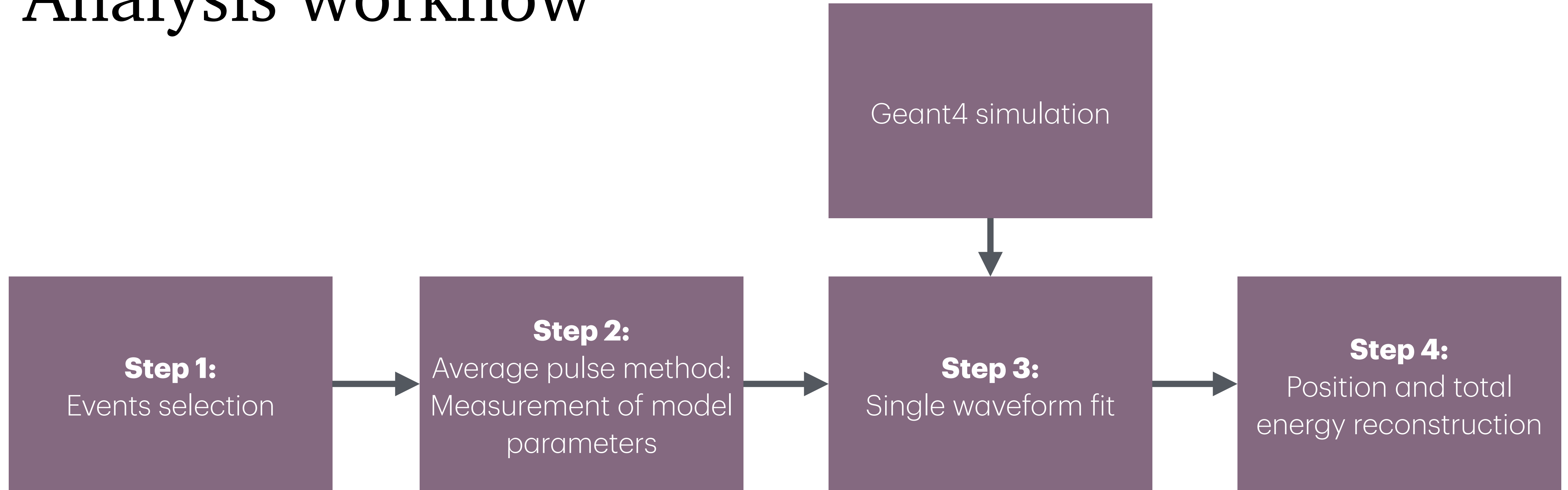

Step 1: Events selection

Define a set of waveform-based variables to process the data.

- Baseline is a good proxy for T_1 , instabilities over time shows some TLS structures
- Filter out “noisy” events with a set of quality cuts

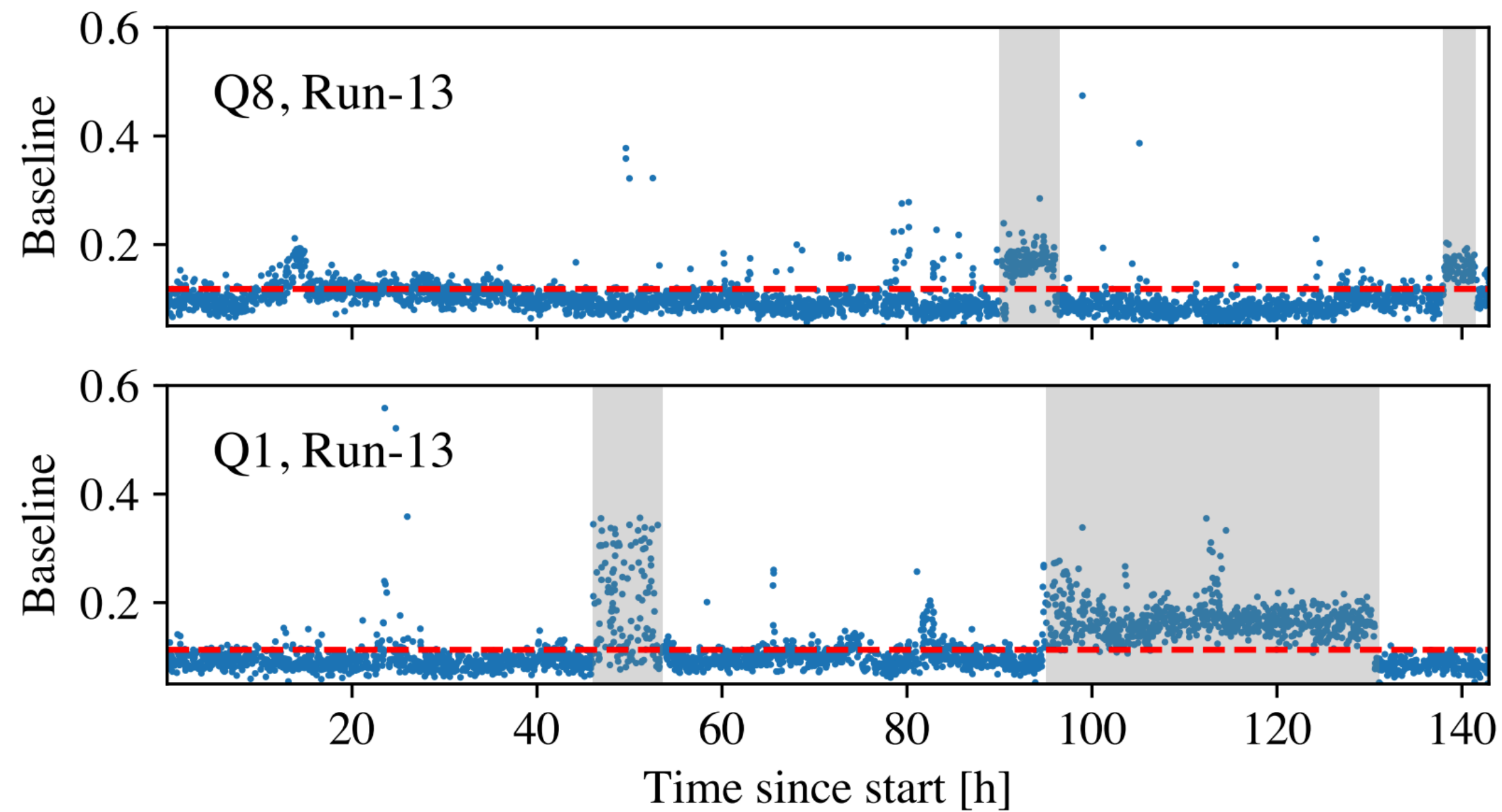

Baseline

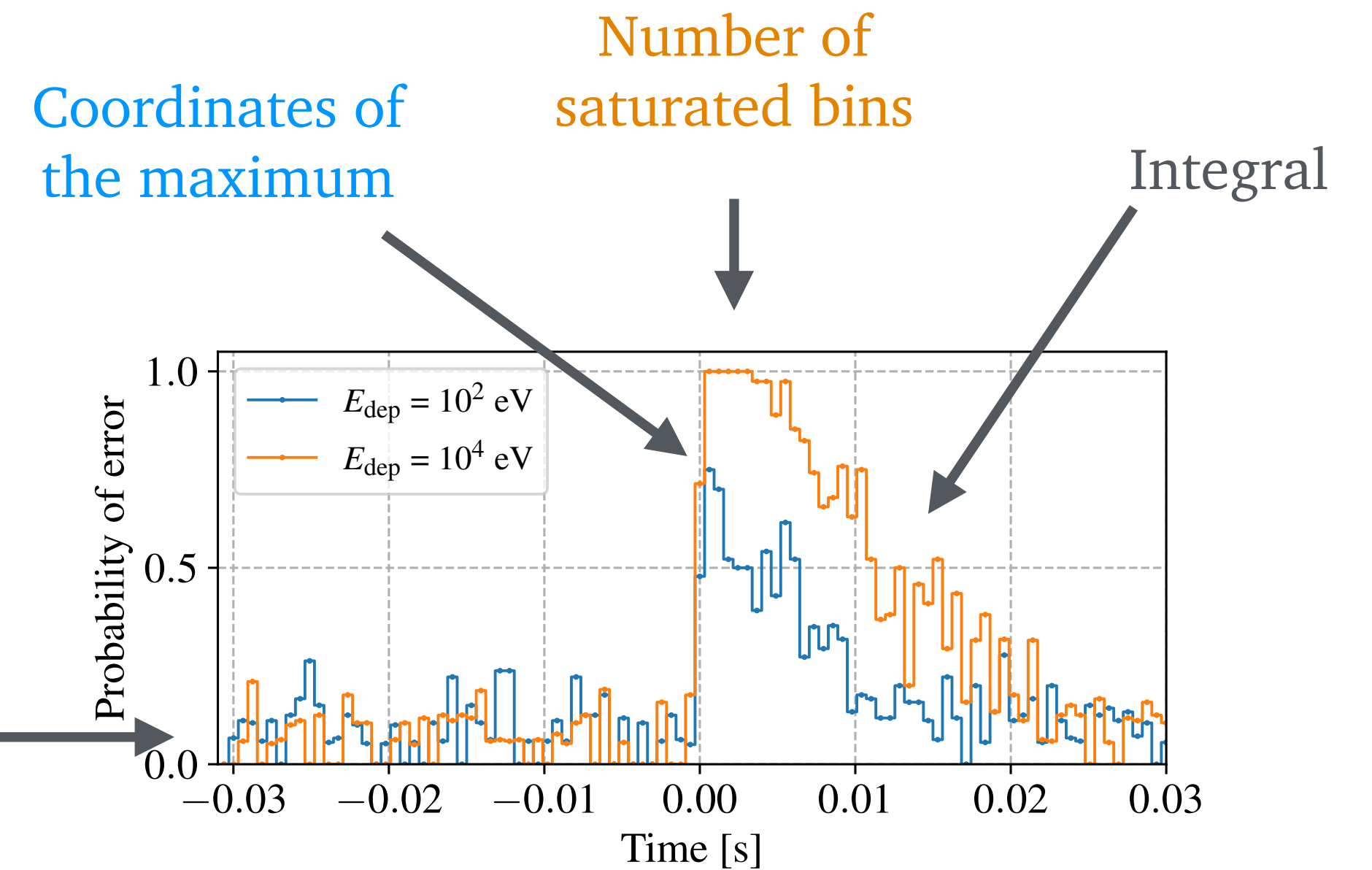

^{137}Cs run

Bkg run

Qubit	Run-07			Run-13		
	ϵ_Q [%]	ϵ_A [%]	ϵ_{tot} [%]	ϵ_Q [%]	ϵ_A [%]	ϵ_{tot} [%]
Q1	76.5	85.5	65.3	63.5	84.9	54.2
Q2	92.4	86.0	79.4	93.3	86.4	81.0
Q4	92.8	84.1	78.2	93.0	84.3	78.1
Q5	74.6	86.0	64.8	91.6	85.0	77.8
Q8	79.7	85.7	68.3	85.9	86.0	73.8
all	36.2	43.9	16.2	41.7	44.6	18.6

Step 2: Average pulse

- 1) Select a set of saturated pulses with a cut on the number of saturated bins → Create average pulse → Extract r and τ_{ss} from average pulse fit
- 2) Select a set of low energy pulses with an amplitude cut → Create average pulse → Extract τ_{ss} from average pulse fit

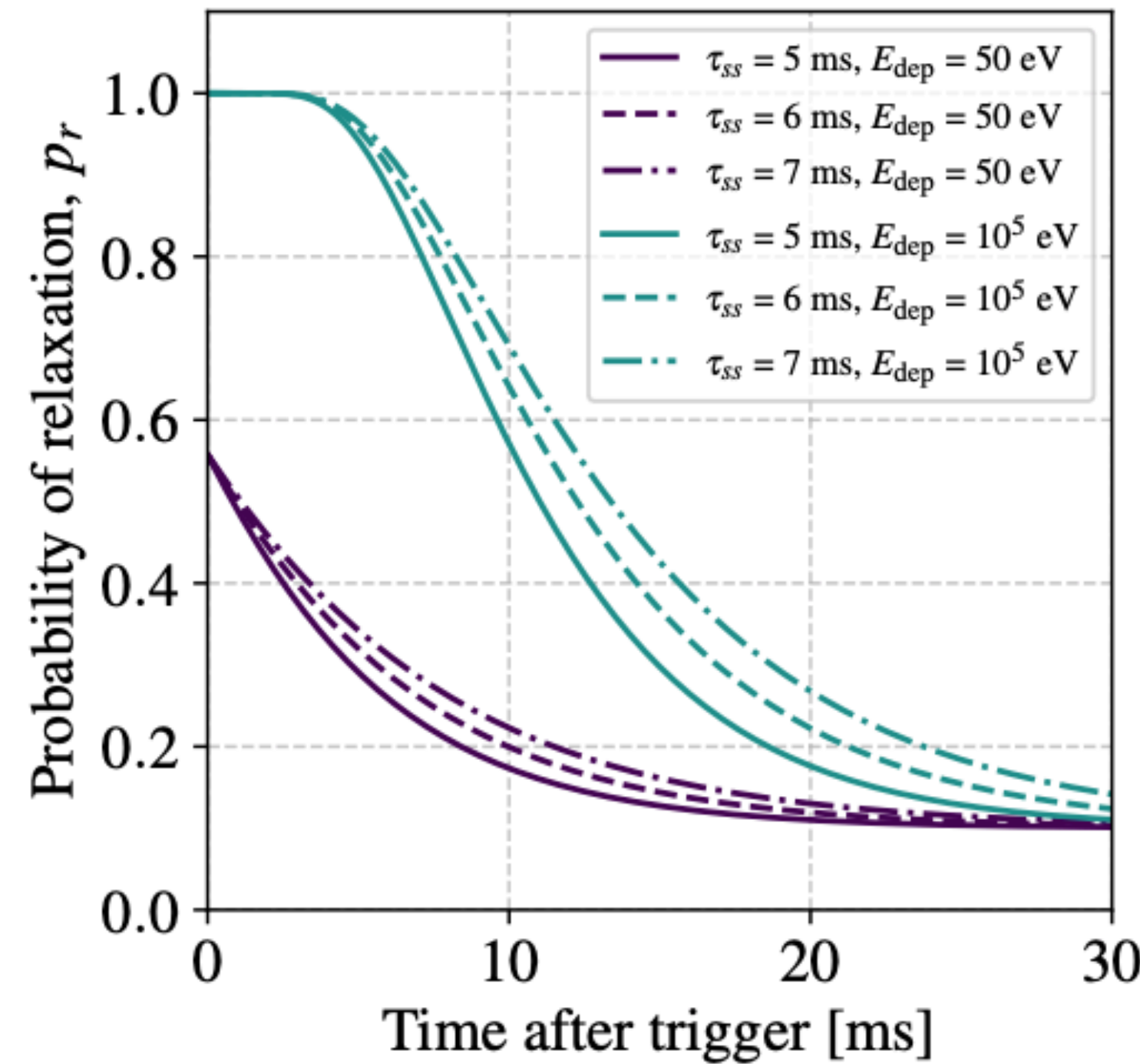
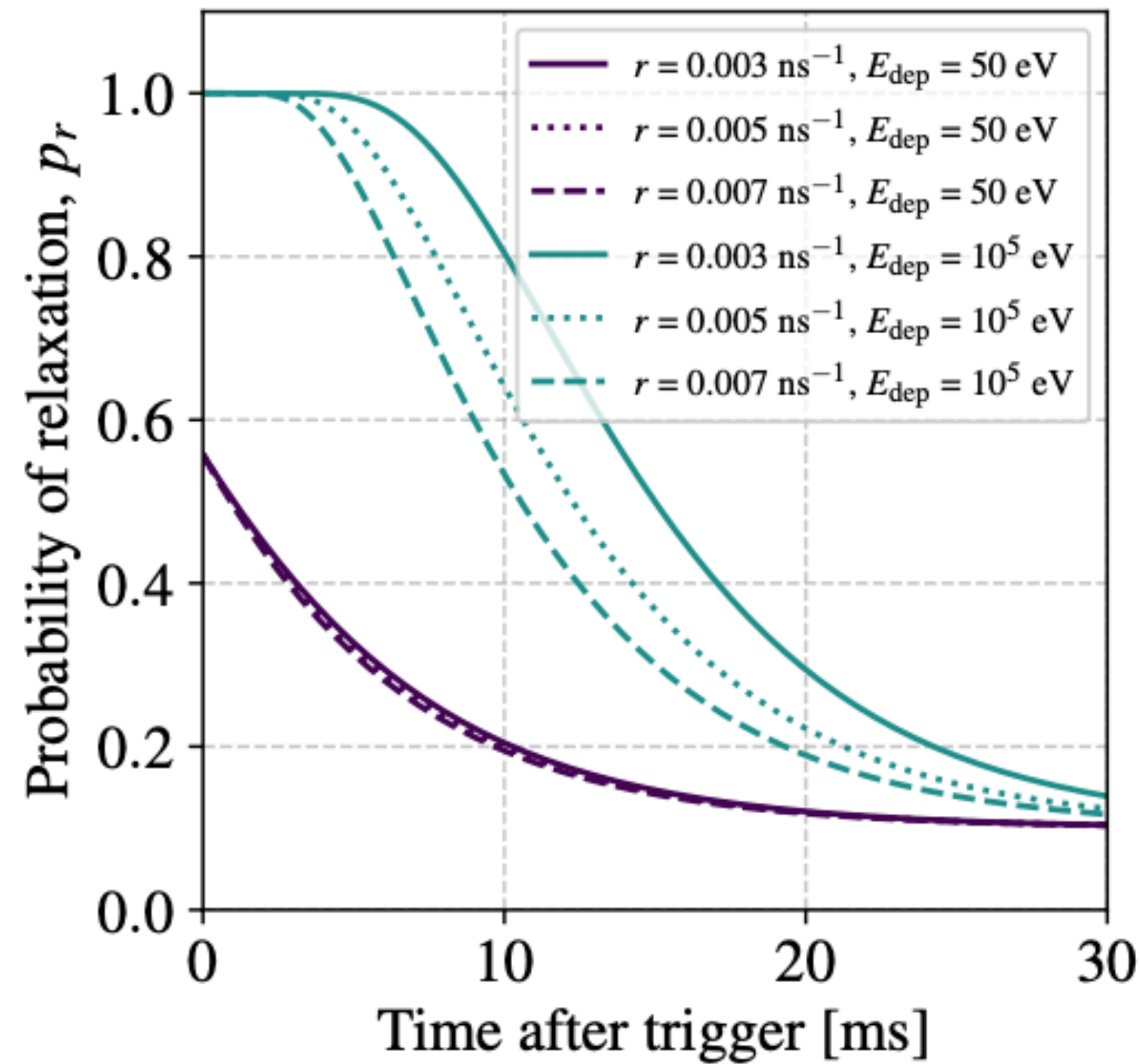

Red: Average pulse

Grey: pulses averaged

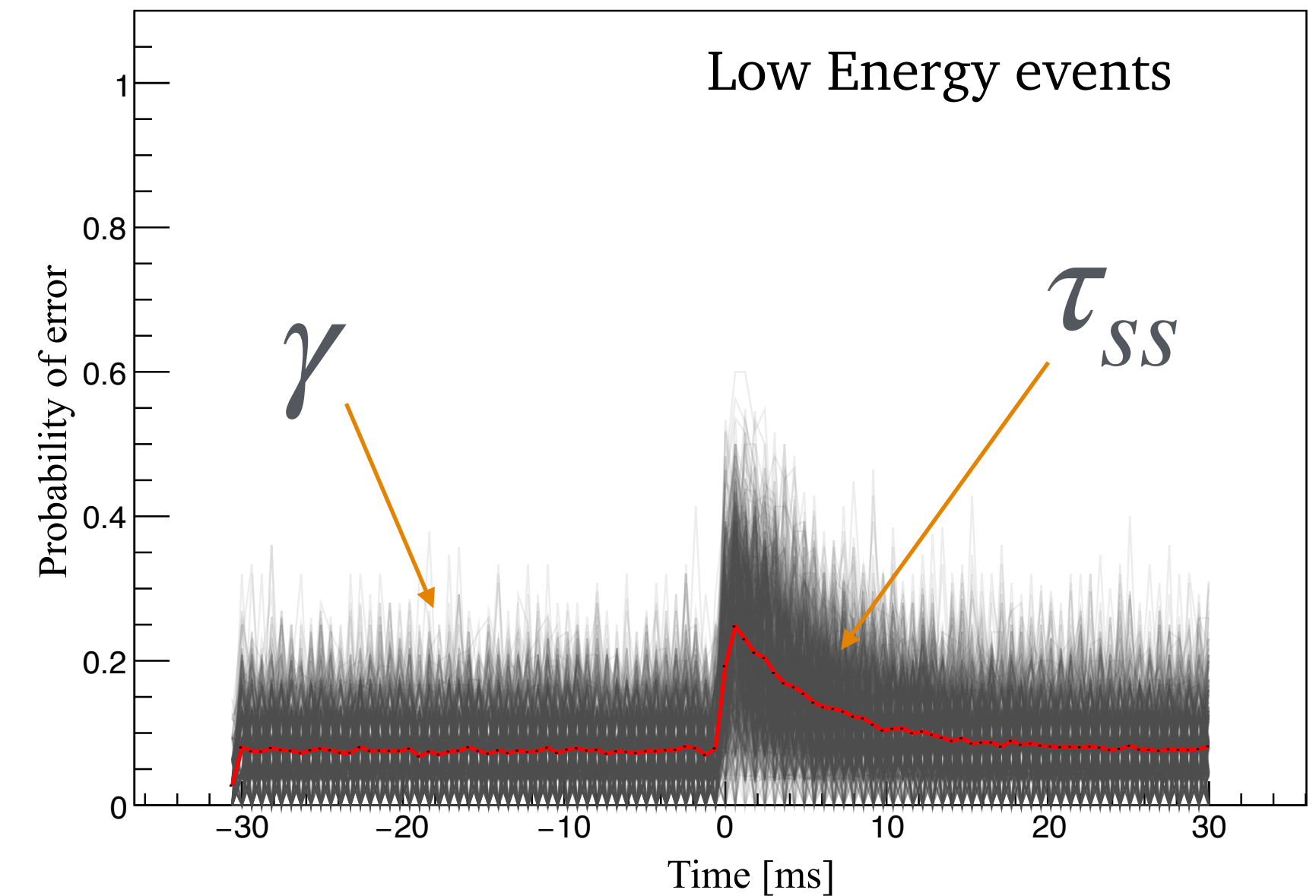
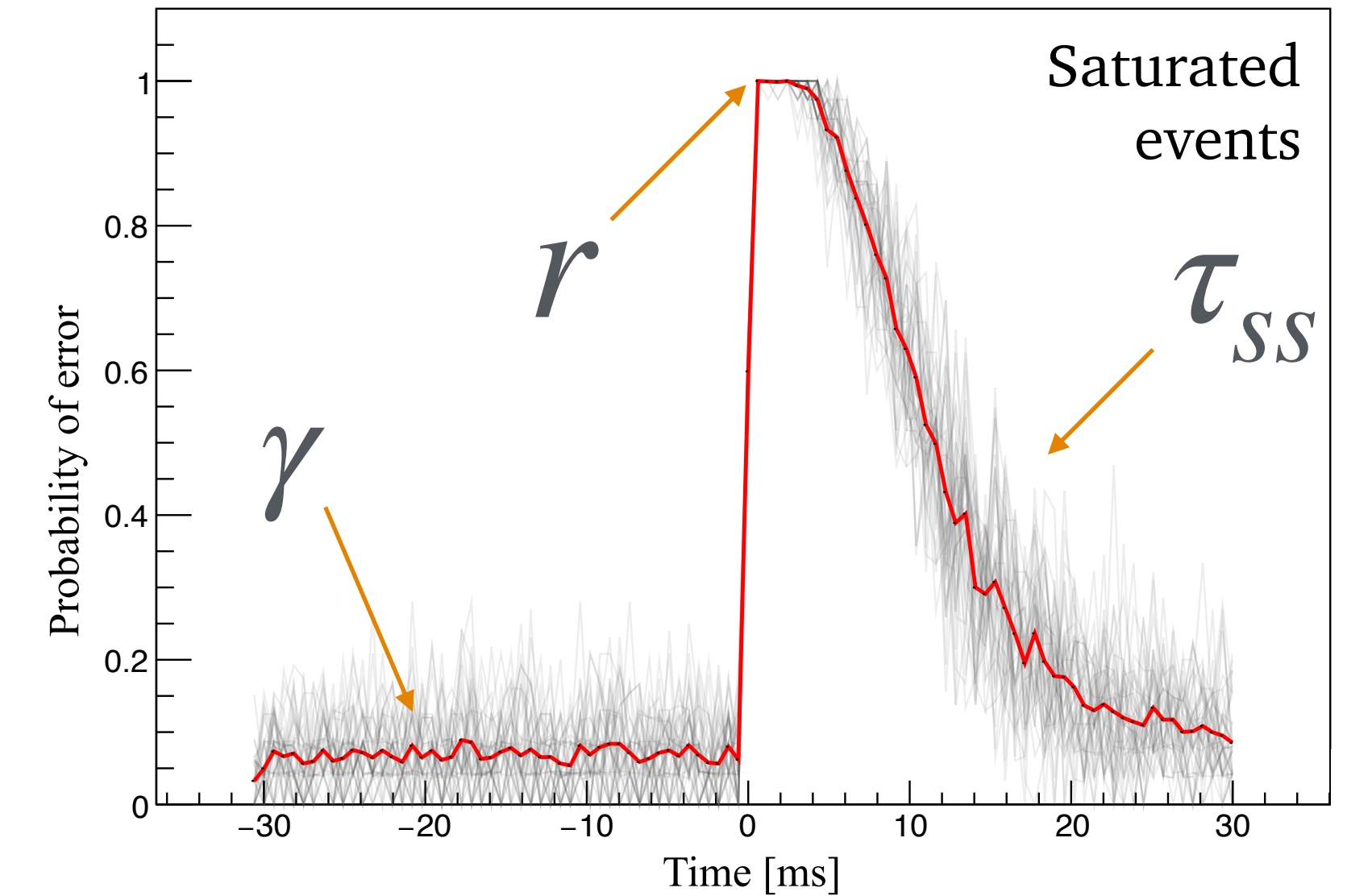

Recombination constant results

- ❖ Good agreement among different datasets
- ❖ Previous measurements of r by other experiments in the range $0.0059\text{--}0.125\text{ ns}^{-1}$
- ❖ In line with previous results, we measured a factor 10 suppression respect to the theoretical expected value $r = 0.05\text{ ns}^{-1}$ in aluminum
- ❖ The analysis on saturated and low energy pulses shows an unexpected dependence of τ_{ss} on the energy deposited

→ other measurements had a dedicated on-chip hardware for artificially producing QP via phonon injectors, we used only radioactivity

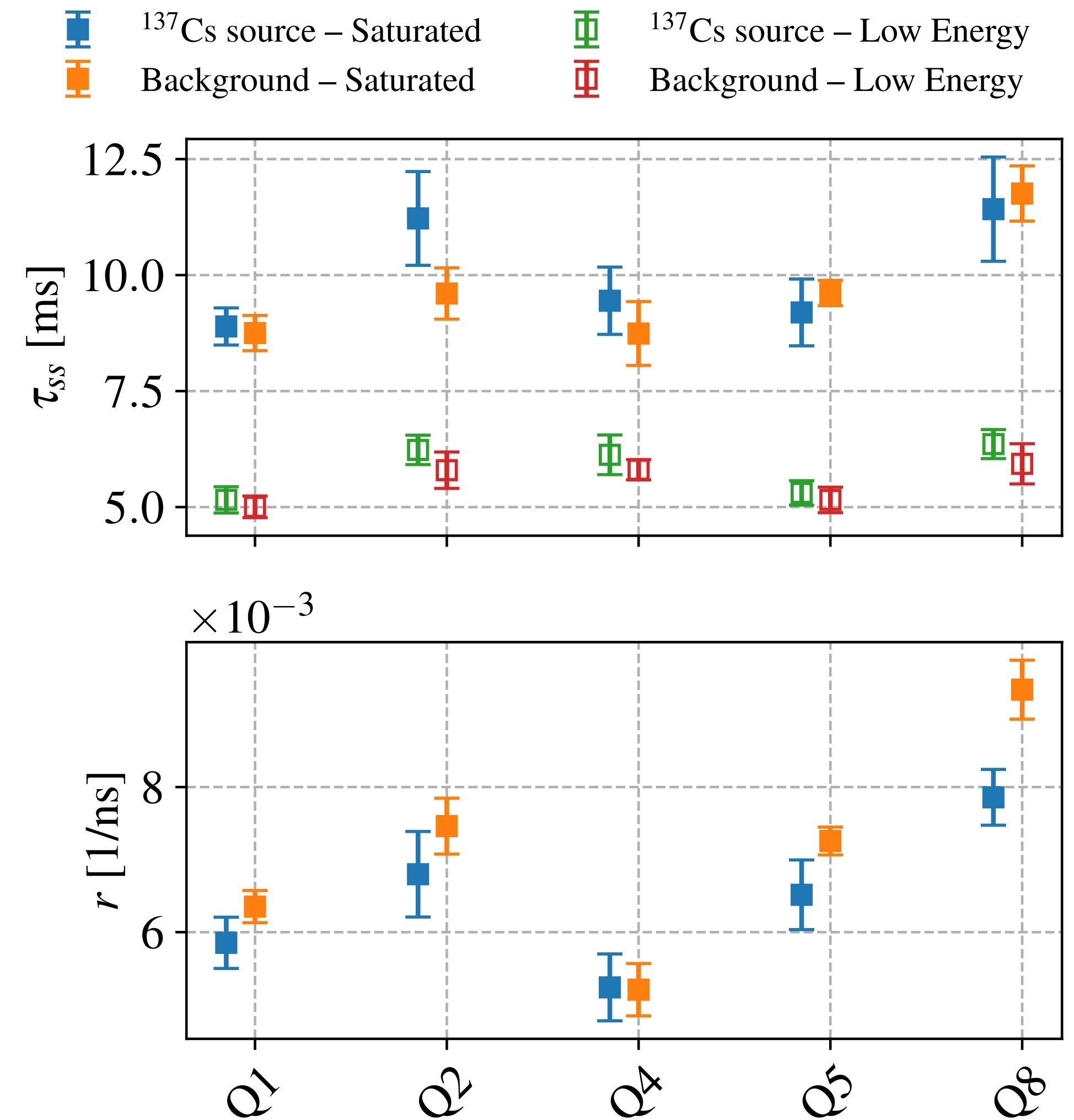

Analysis workflow

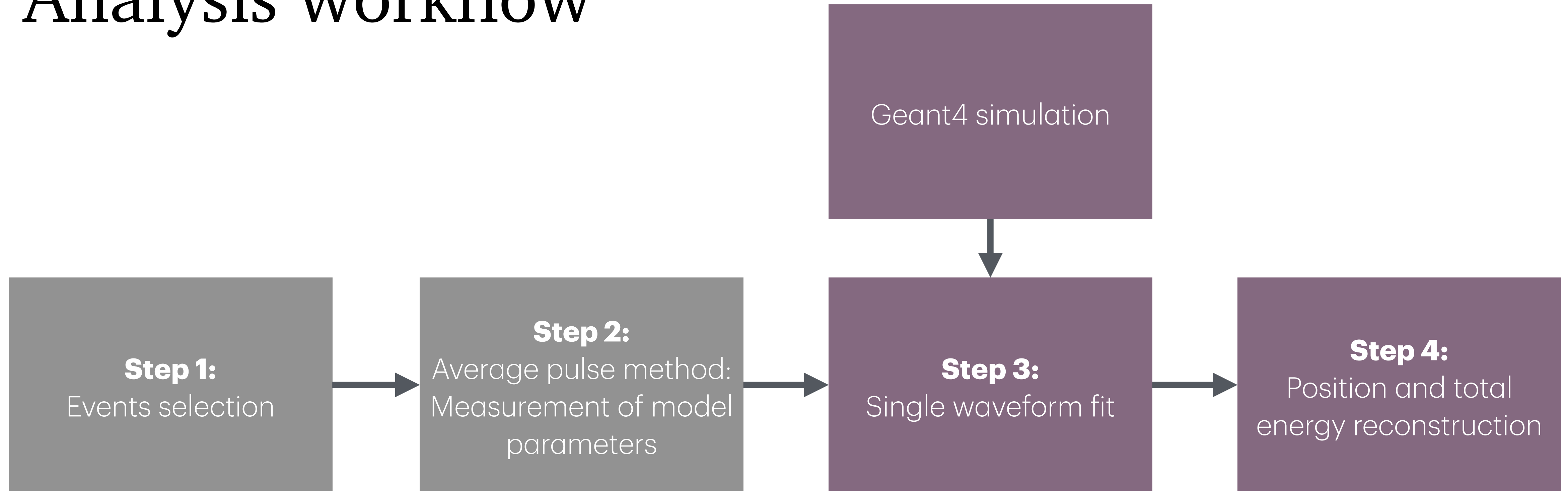

Step 3: Waveform fit

For all correlated errors detected, fit each qubit waveform with QP density model:

- r estimated independently with the average pulse method
- fit uncertainty depends strongly on E_{dep}

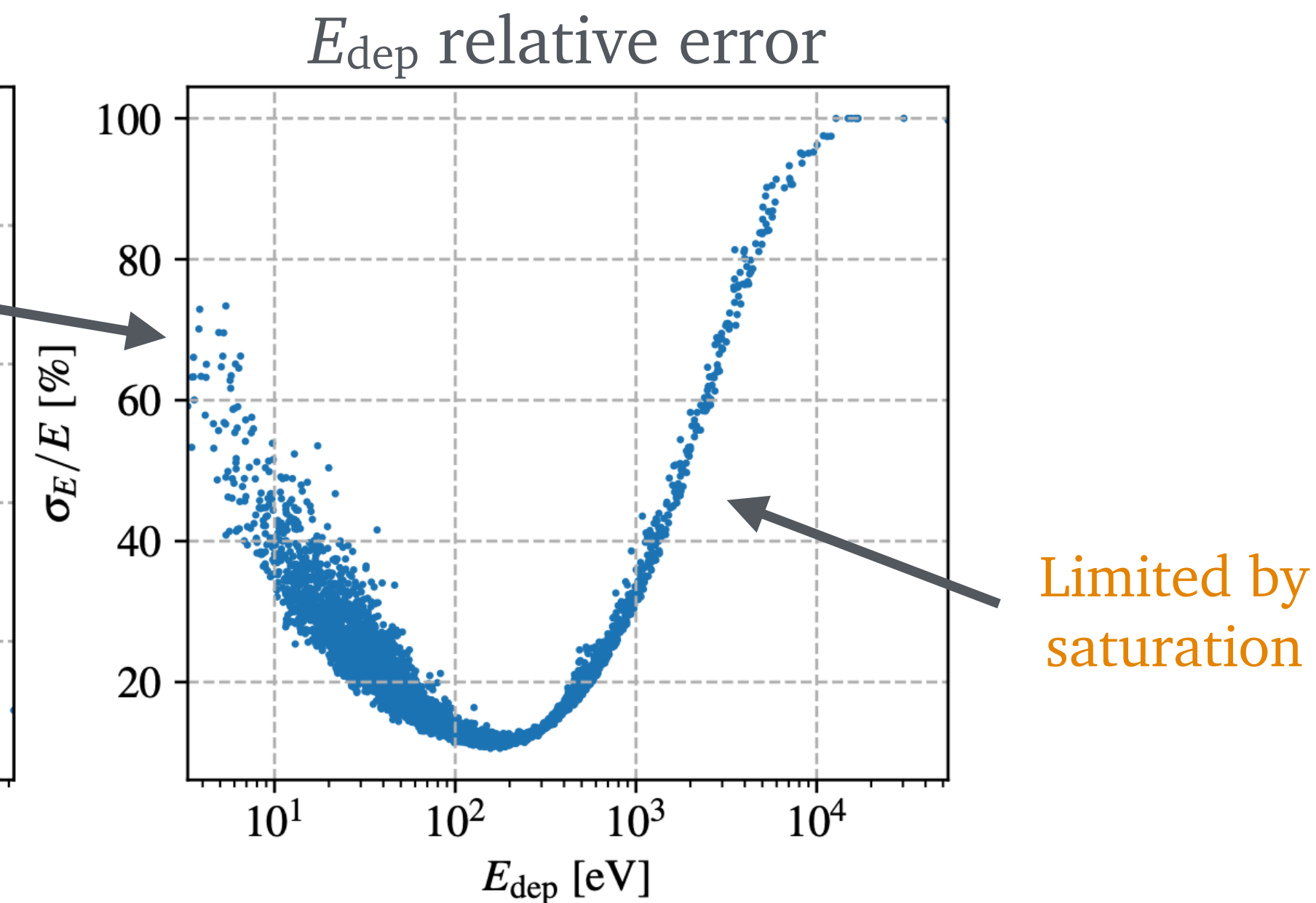
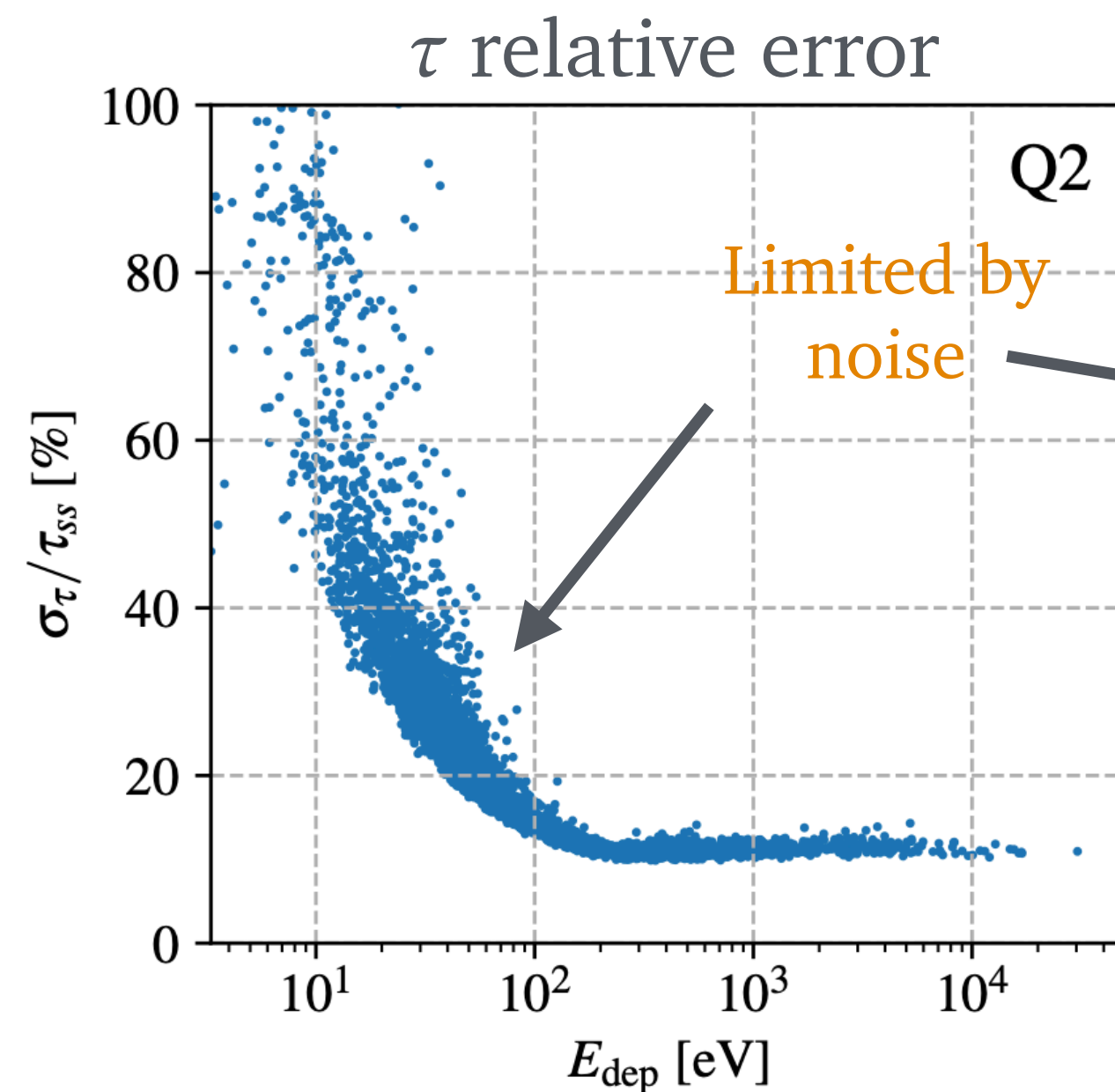
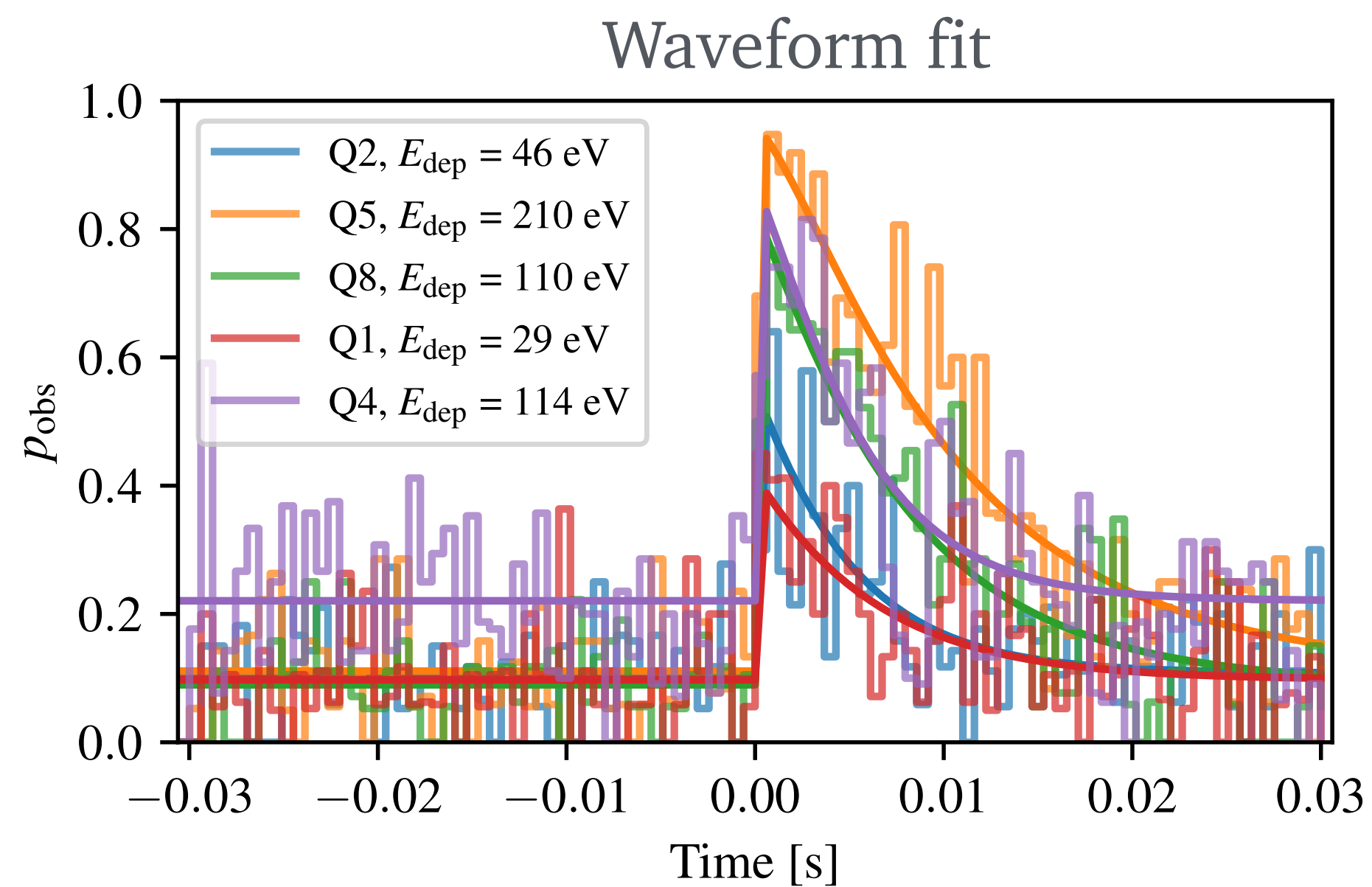
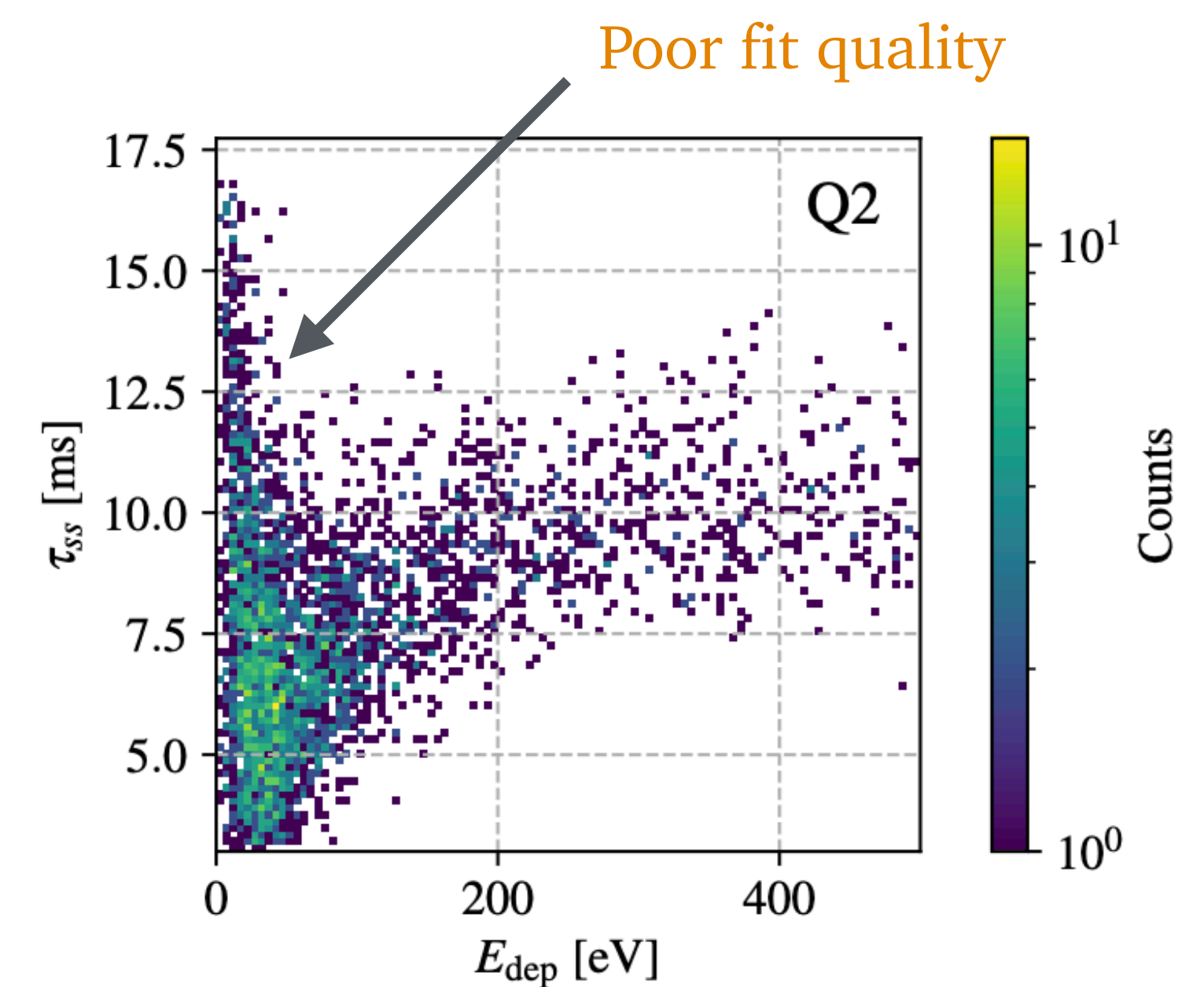

Amplitude correlation by qubit

CP breaking process is activated by athermal phonons which keep the information about event position
→ energy deposited is correlated among qubits

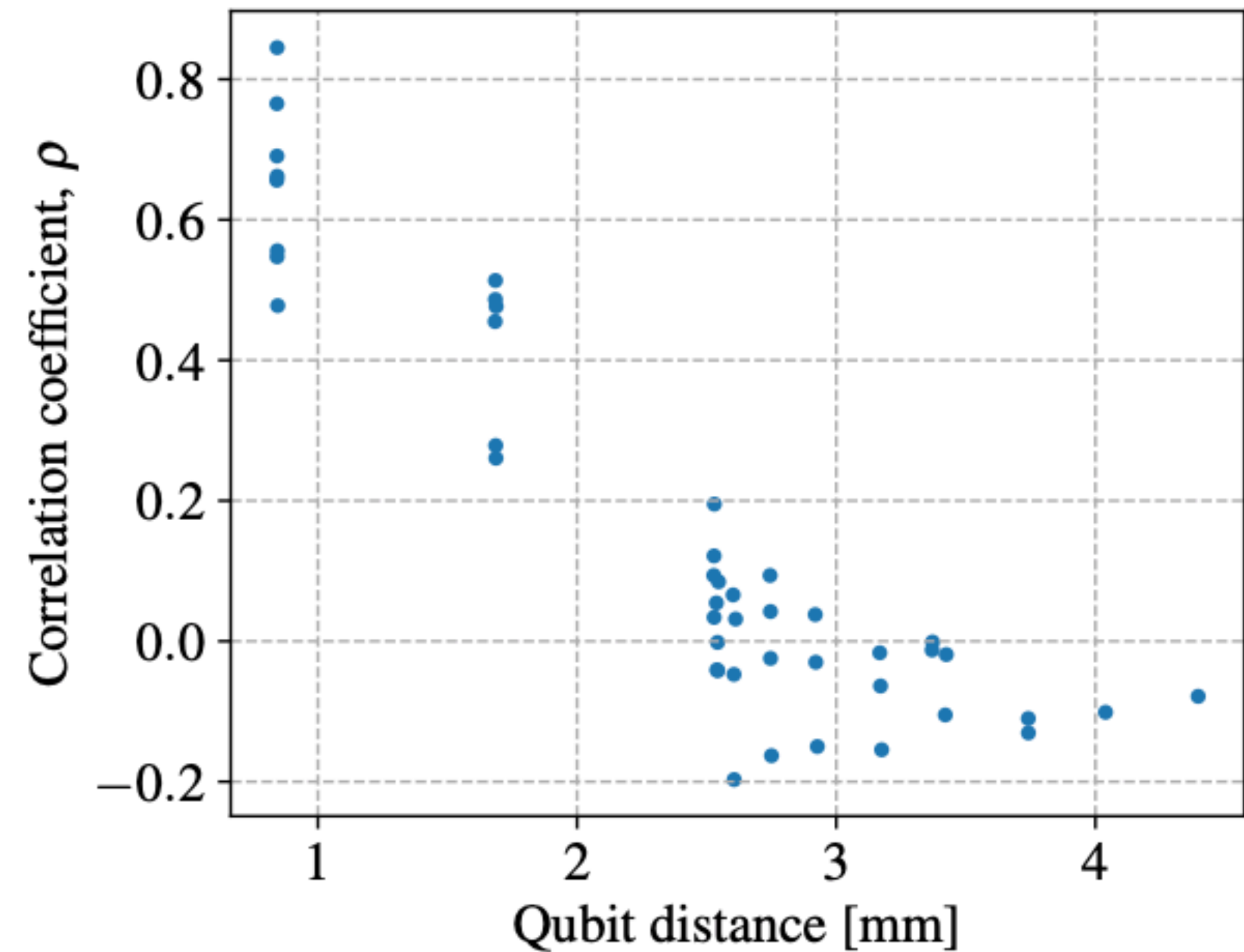
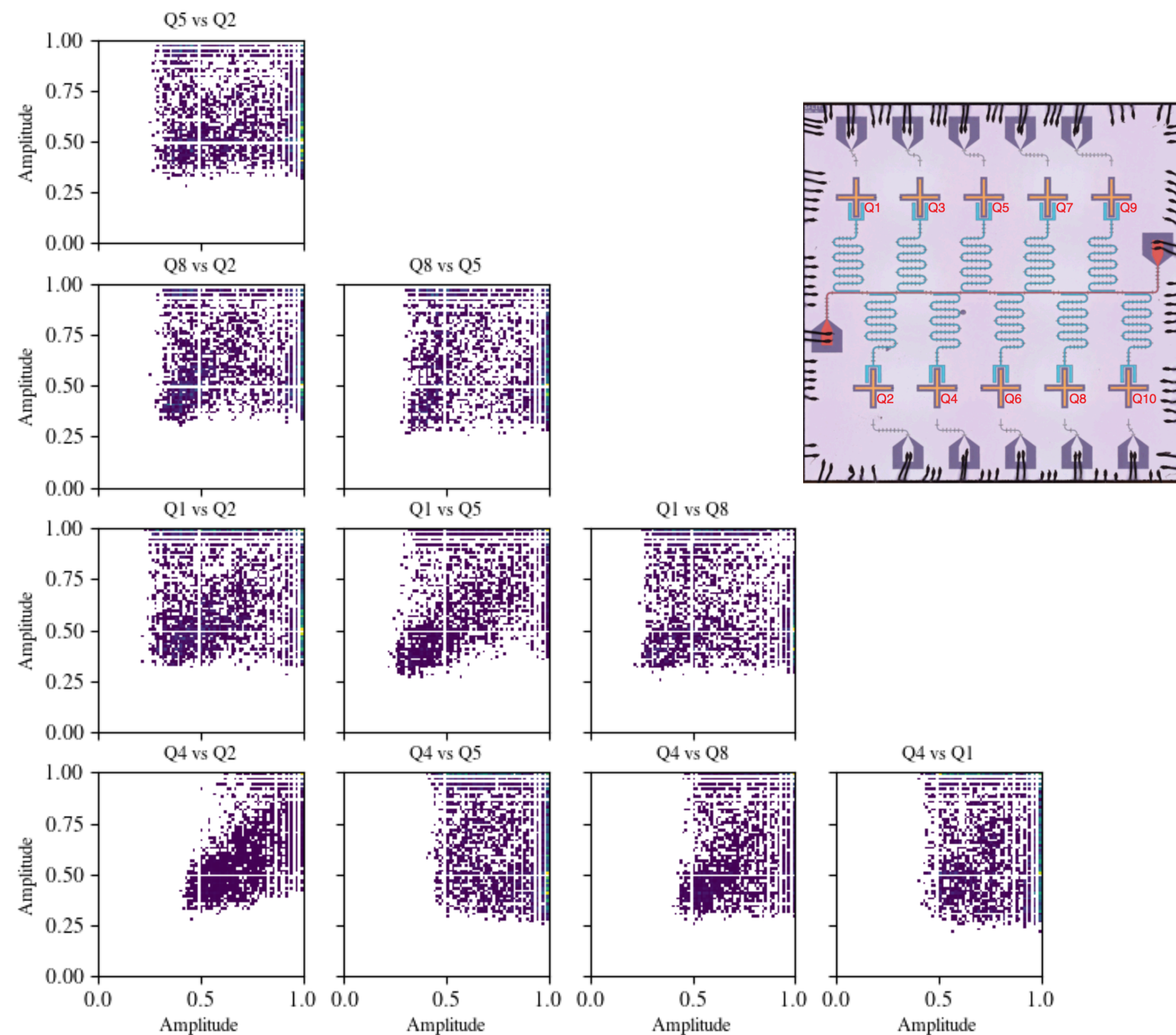

Step 4: Position reconstruction

Single-qubit energy deposited from waveform fit

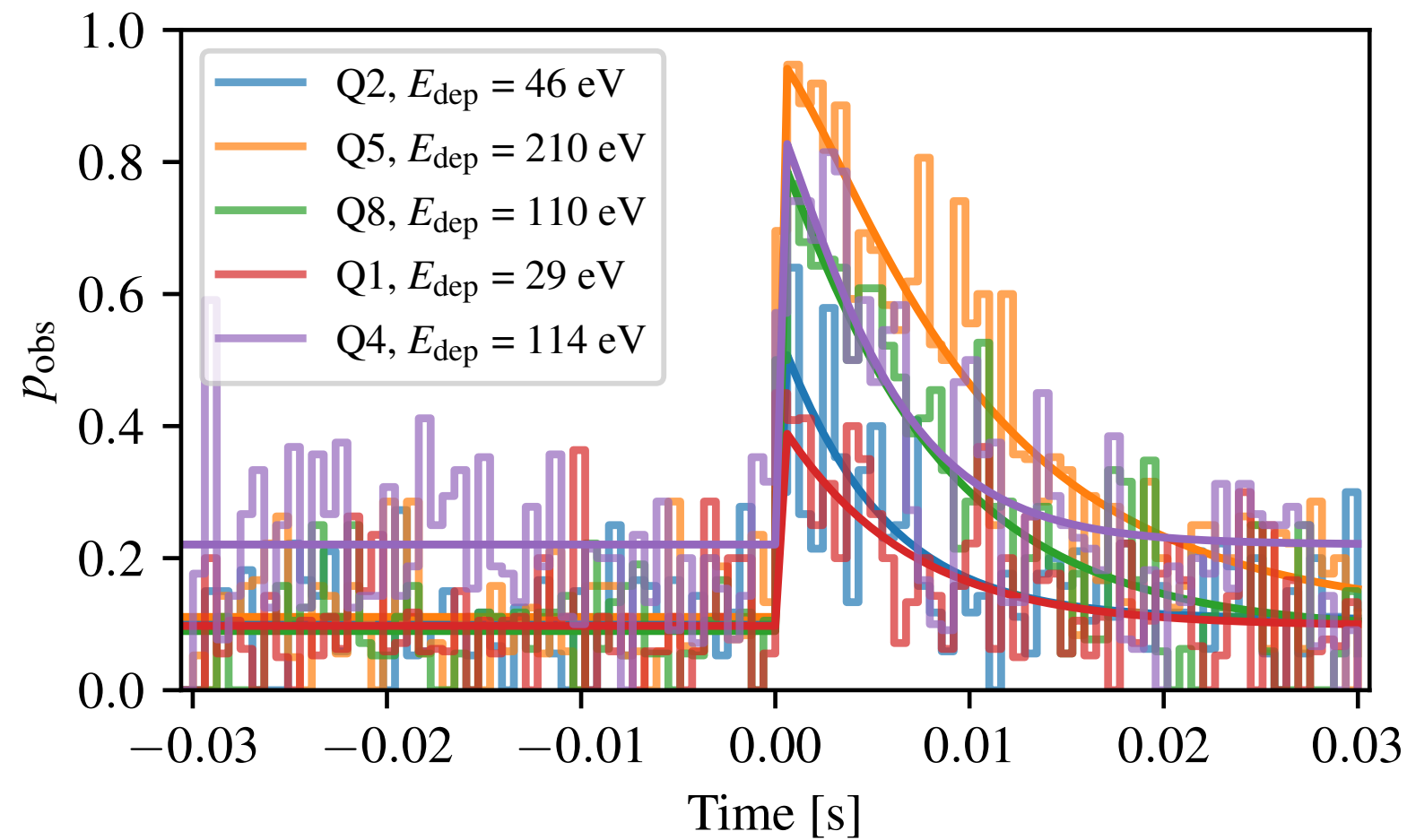

+ Phonon collection efficiency from G4CMP

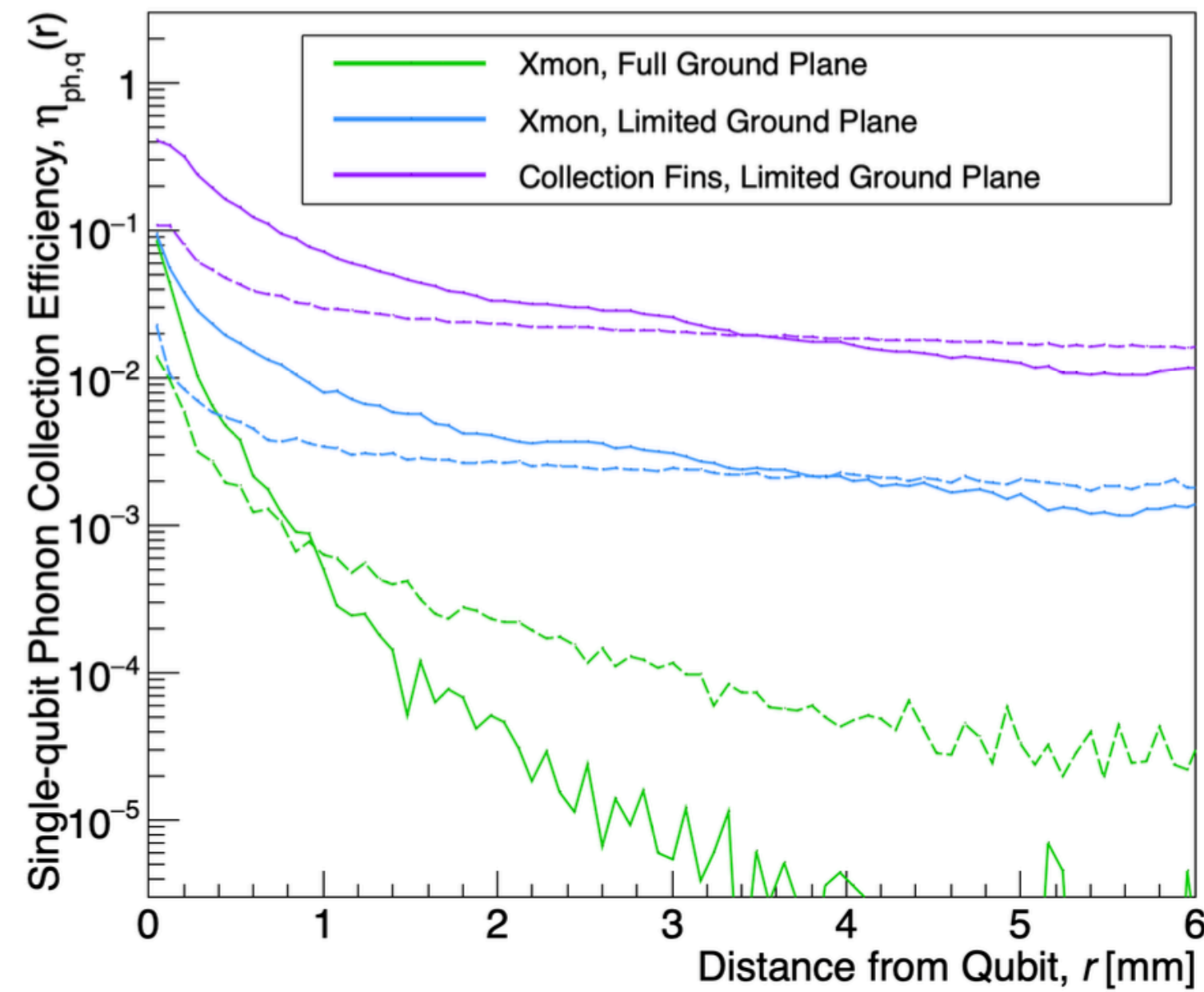

=

Total energy and position reconstruction

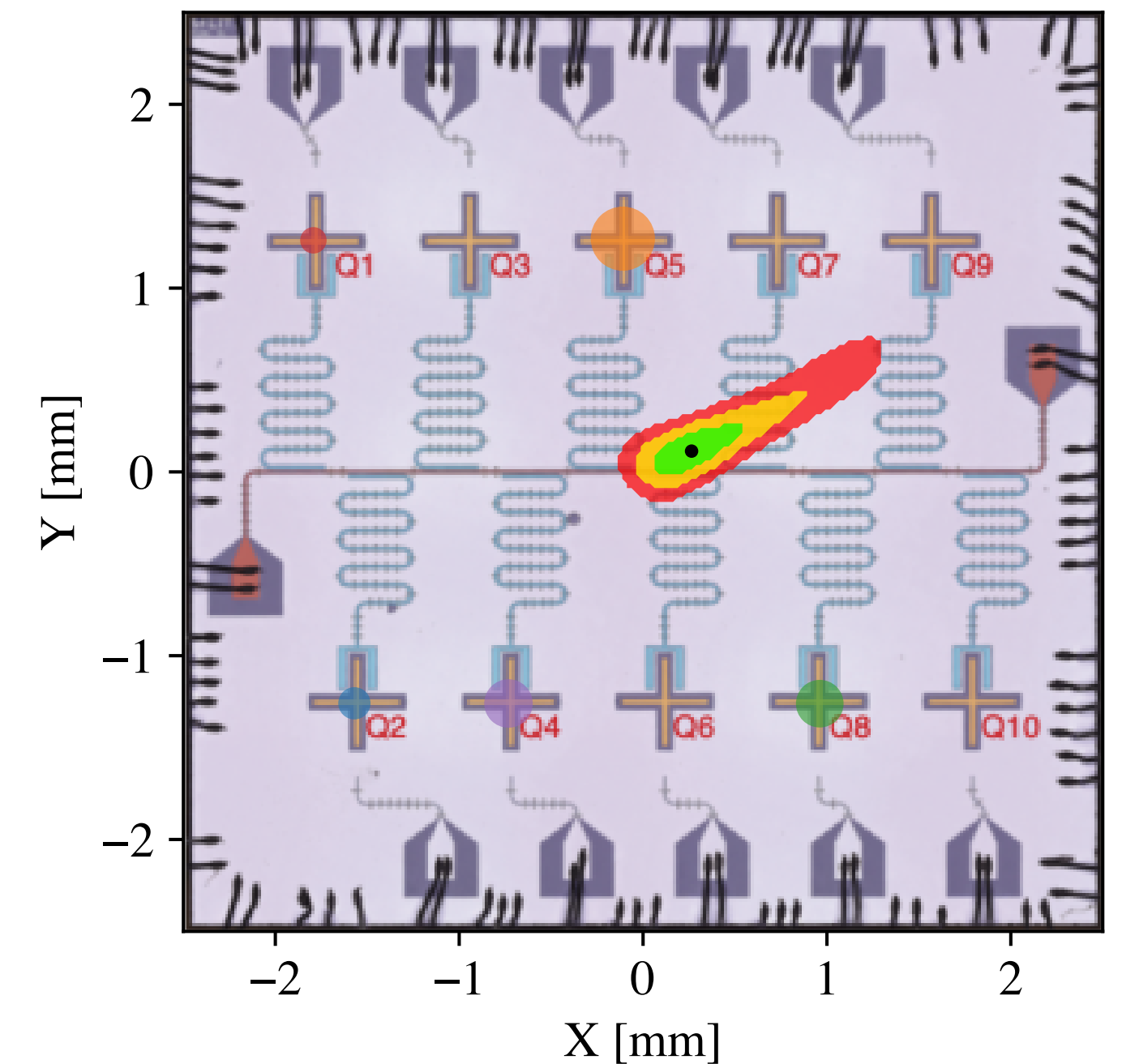

[Linehan et al, \(2024\)](#)

Total energy spectrum \rightarrow ^{137}Cs data

Combining information from energy deposited in the qubit island and G4CMP phonon collection efficiency, we can reconstruct the vertex of the interaction and the total energy released in the substrate.

- ❖ Reject every correlated event where any of the qubits do not pass quality and analysis cuts
- ❖ Additional geometrical cut: phonon reflections can alterate reconstructed energy

Qubit	Run-07		
	ϵ_Q [%]	ϵ_A [%]	ϵ_{tot} [%]
Q1	76.5	85.5	65.3
Q2	92.4	86.0	79.4
Q4	92.8	84.1	78.2
Q5	74.6	86.0	64.8
Q8	79.7	85.7	68.3
all	36.2	43.9	16.2

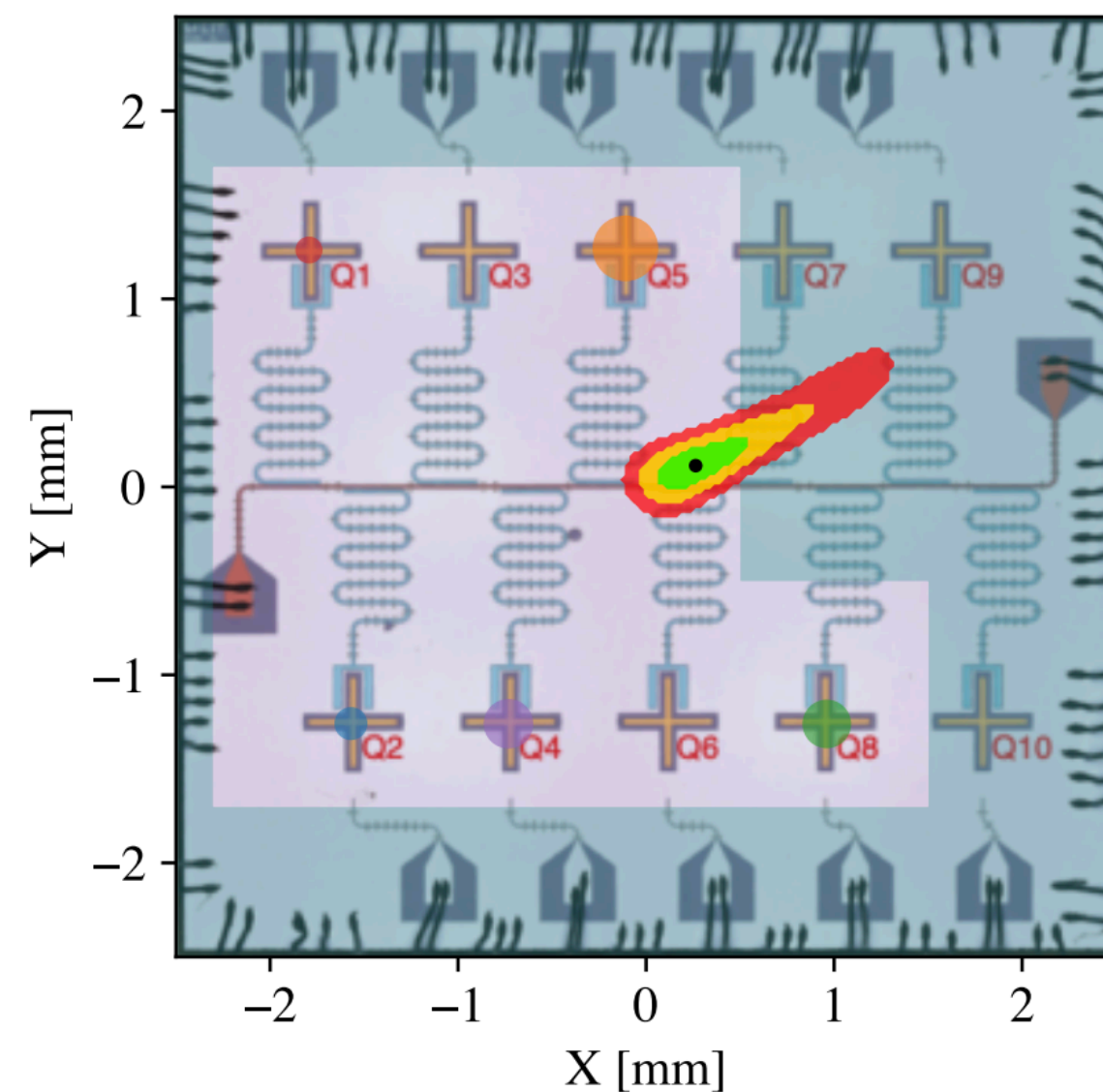

Reconstructed ^{137}Cs energy spectrum

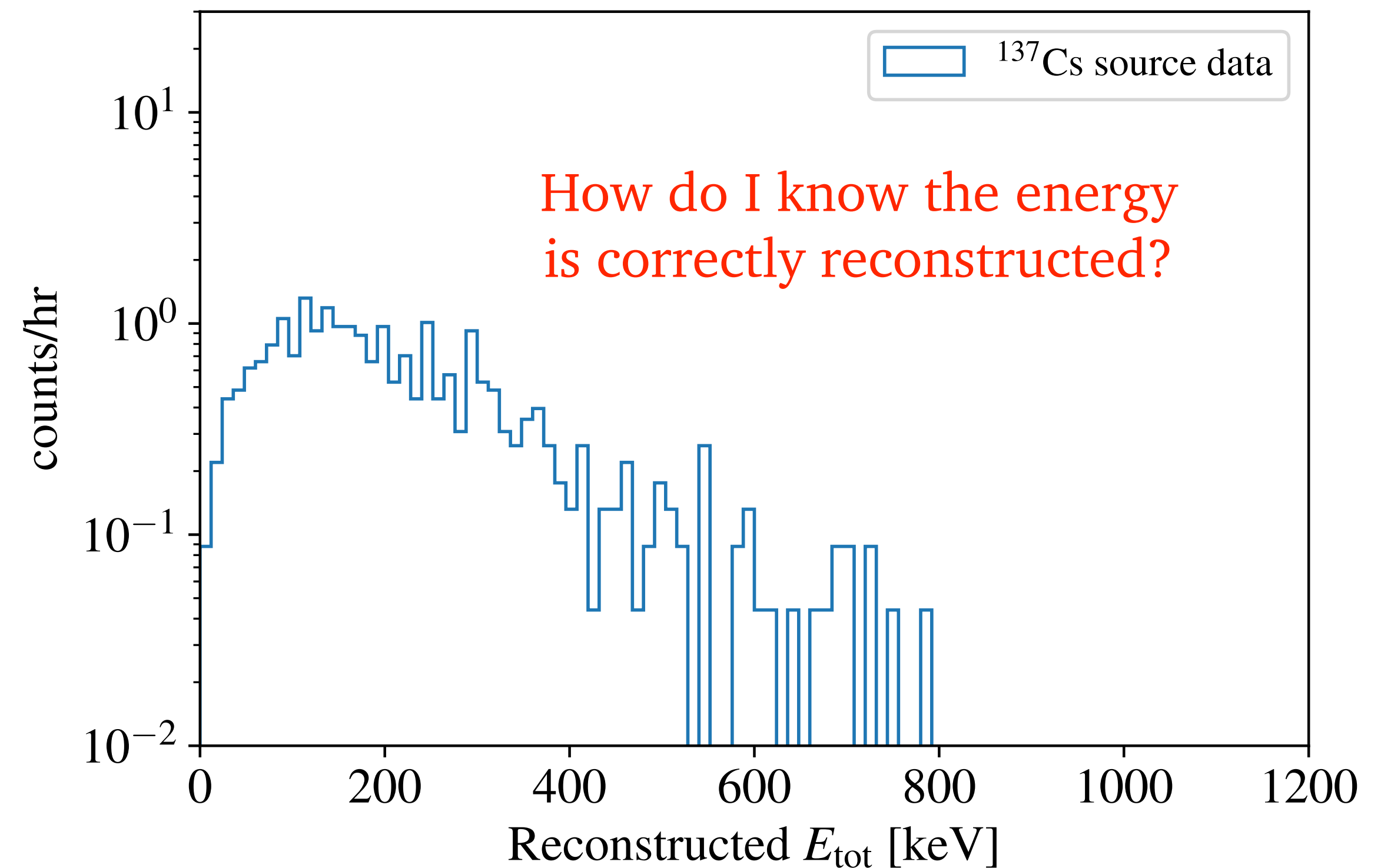

Geant4 validation

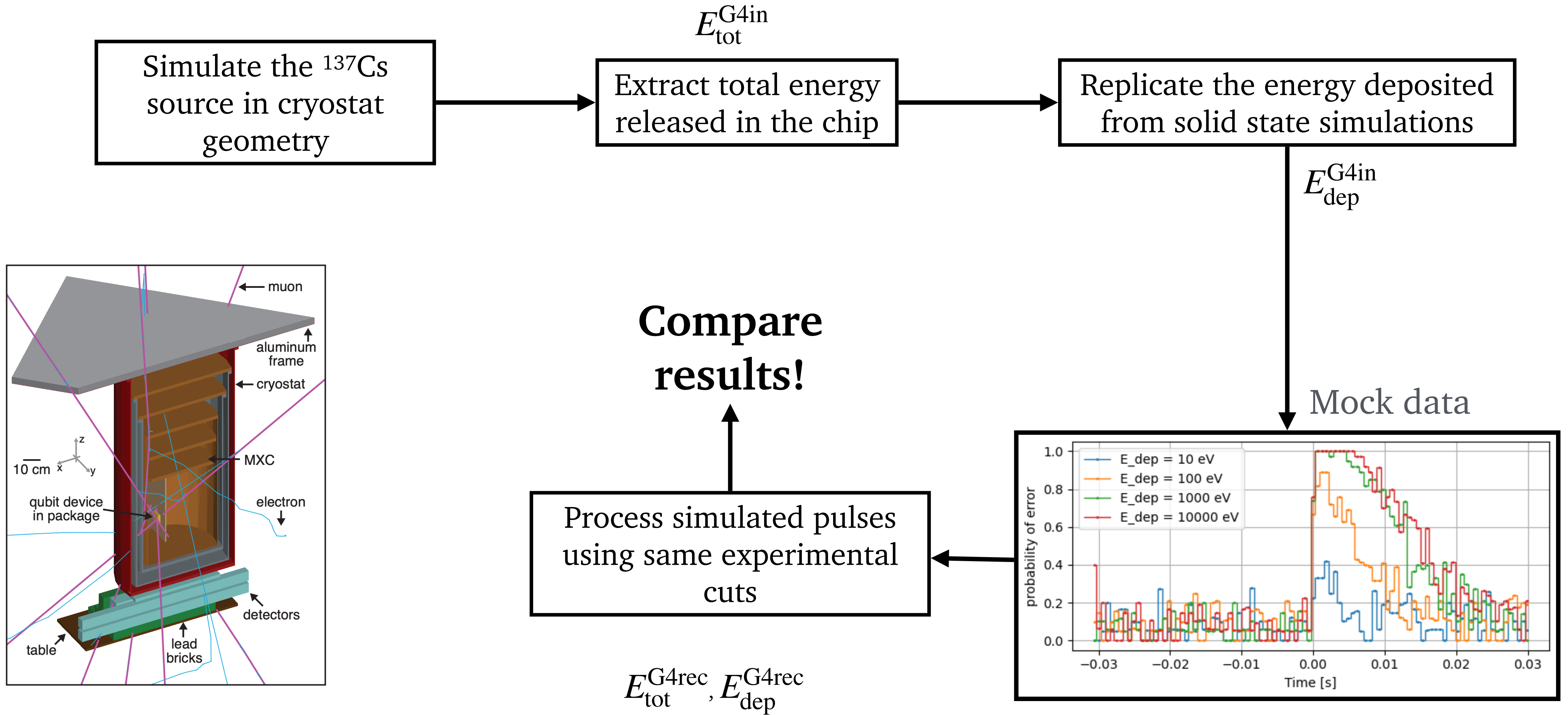

Energy spectrum \rightarrow ^{137}Cs data + simulation

Applying same analysis cuts are for processed Geant4 waveforms and real data, the agreement among the two spectra is pretty good. Slope difference to be attributed to simulation uncertainties on the probability of phonon absorption and the substrate interfaces

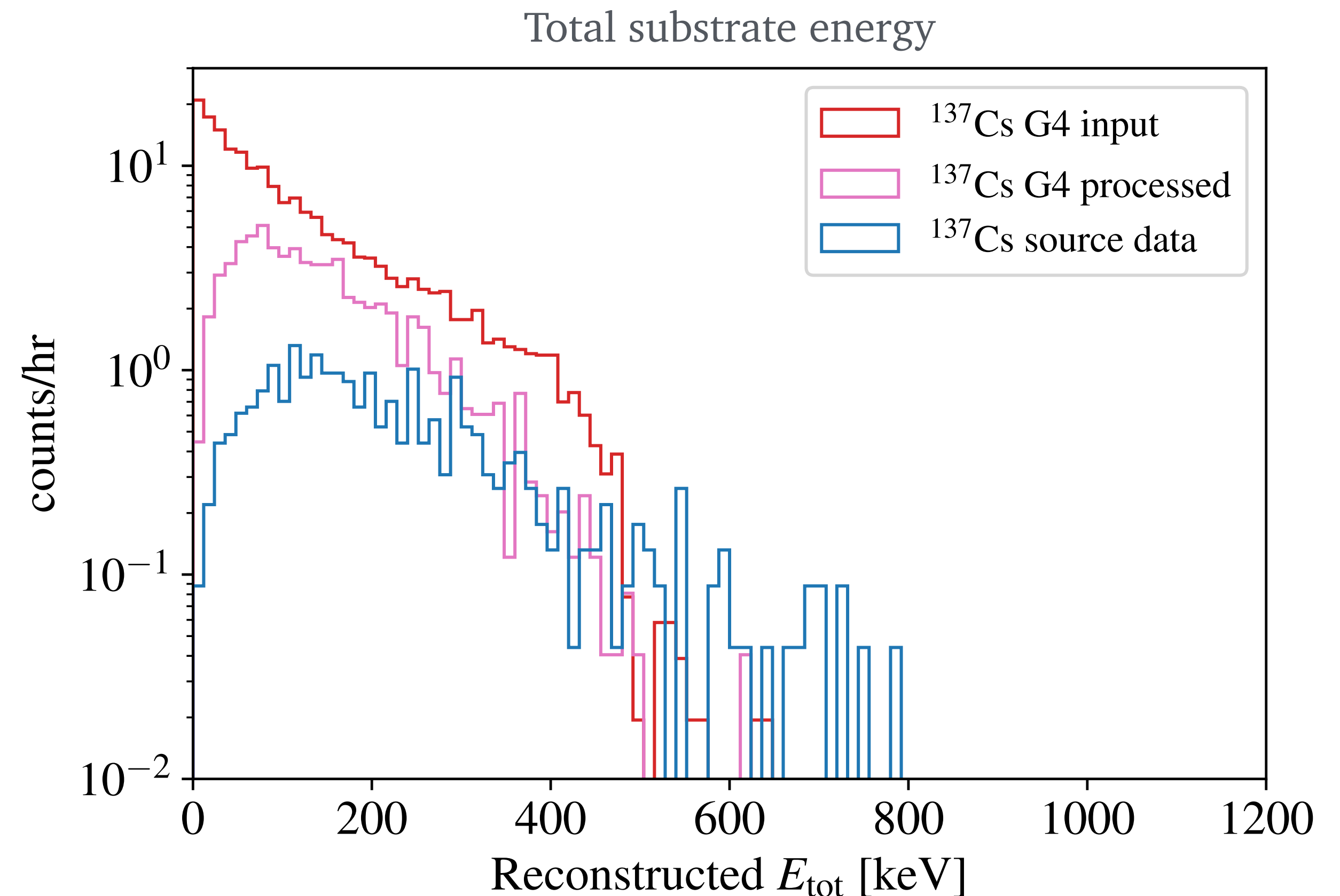
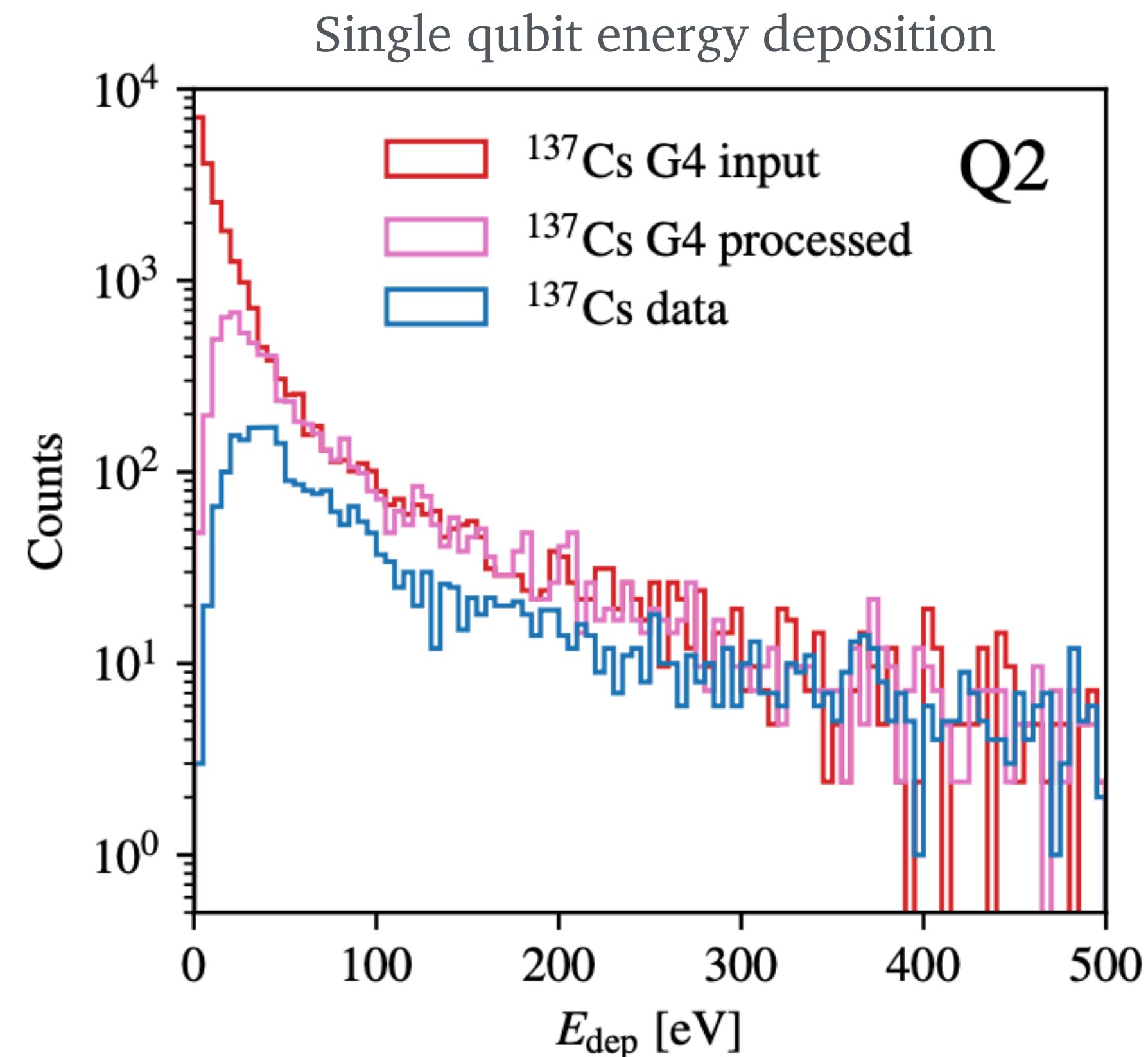

Conclusion of this work



- ❖ This work demonstrates that the pulse shape of correlated decoherence events is extremely useful in understanding qubits' response as sensors
- ❖ Superconducting qubit arrays can be used as potential tools to sense position and total energy for particle detection
 - A **dedicated measurement** with energy and position calibration is essential to validate the method and reduce systematics

Acknowledgments:

- ❖ **NU/FNAL:** Emanuela Celi, Dan Baxter, Tali Figueroa-Feliciano, Ryan Linehan
- ❖ **MIT/LL:** Will Oliver, Kyle Serniak, Joe Formaggio, Patrick Harrington, Doug Pinckney, Mingyu Li
- ❖ My involvement in this work has been done through Northwestern's participation in the Quantum Science Center.



CosmiQuantum group

NU + FNAL + IIT + others

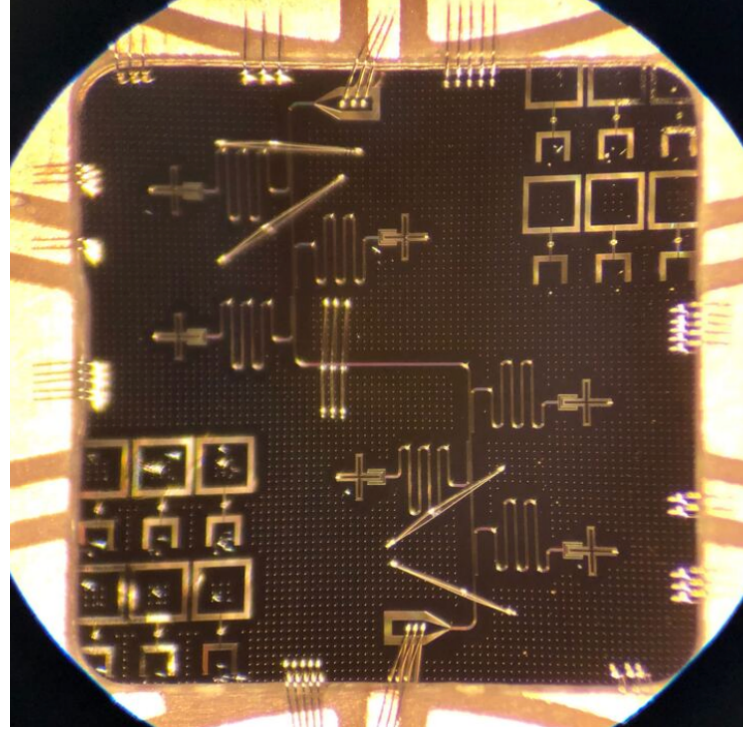

- 2 cryostats (QUIET and NEXUS) in MINOS tunnel (230 m.w.e.)
+ LOUD aboveground at FNAL
- Fabrication facilities
- Multiple collaborations with companies and other institutions

Projects ongoing:

- DM and neutrino physics (SuperCDMS, RICOCHET + others)
- Qubit design and fabrication
- Testing fundamental quantum mechanics
- Testing effects of radioactivity on qubits
- G4CMP development
- MKID R&D
- Quantum acoustic detectors
- + Many more



Collaborators
FNAL/IIT/++:
Lauren Hsu
Daniel Baxter
Rakshya Khatiwada
Daniel Bowring
Gustavo Cancelo
Ryan Linehan
Sho Uemura
Dylan Temples
Sara Sussman
Kester Anyang
Israel Hernandez
Ziyu Cai
Jehu Martinez
Arjun Uppal

Chris James
Olivia Seidel
Joyce Christiansen-Salameh
Daniel Molenaar
Tilly Schaaf
Muntu Munaf

Northwestern:
Enectali Figueroa-Feliciano
Pratyush Patel
Grace Bratrud
Arianna Colón Cesaní
Alejandro Rodriguez
Firas Abouzahr
Kyle Kennard



Quasiparticles and TLS studies



+ others

- Taking advantage of the underground radiation protected environment to understand radiation effects on superconducting qubits
- Understanding the effect of alpha environmental radioactivity for correlated errors and TLS formation.
- Correlation between ionizing radiation and TLS
- Radiation sensing with excited states

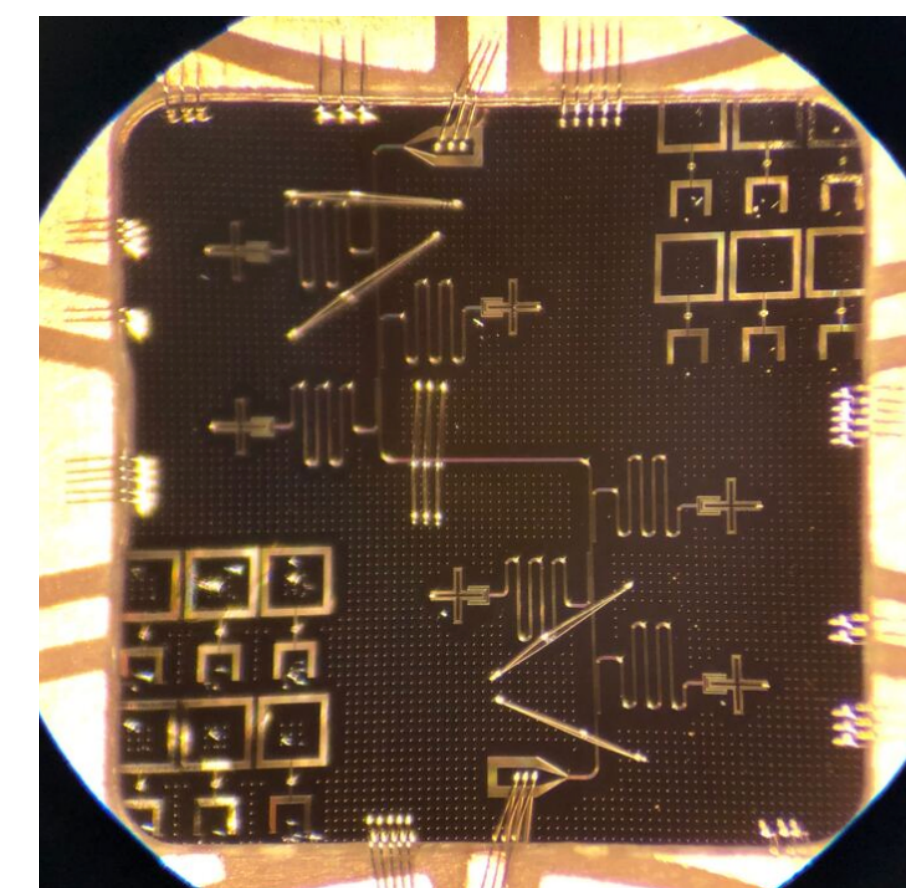
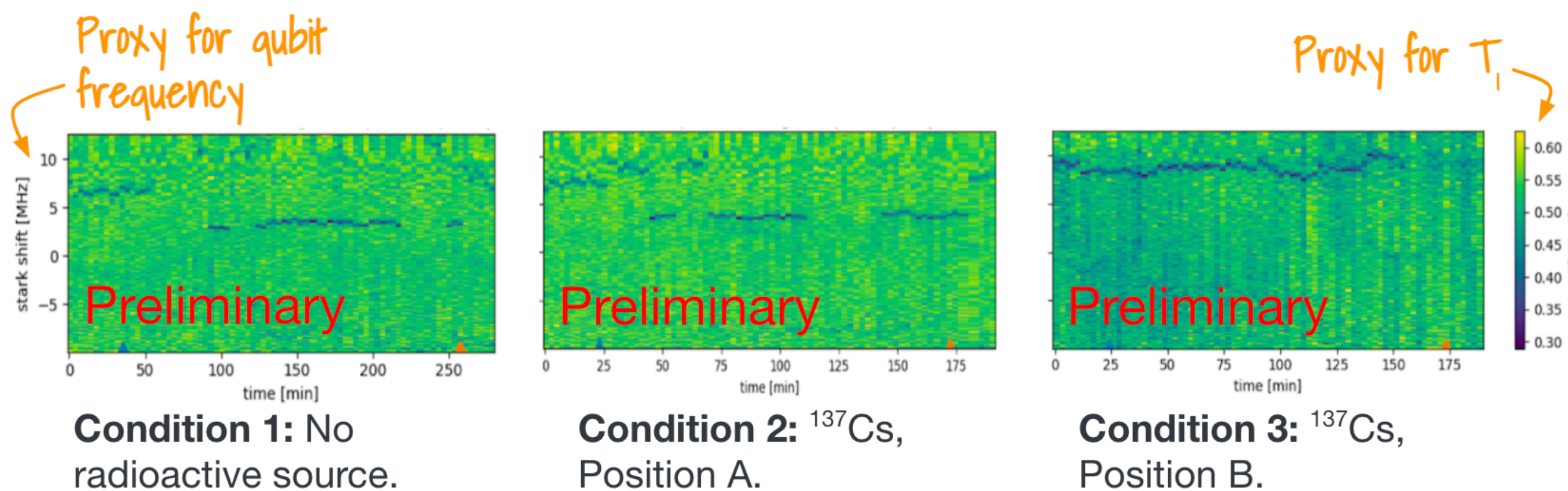
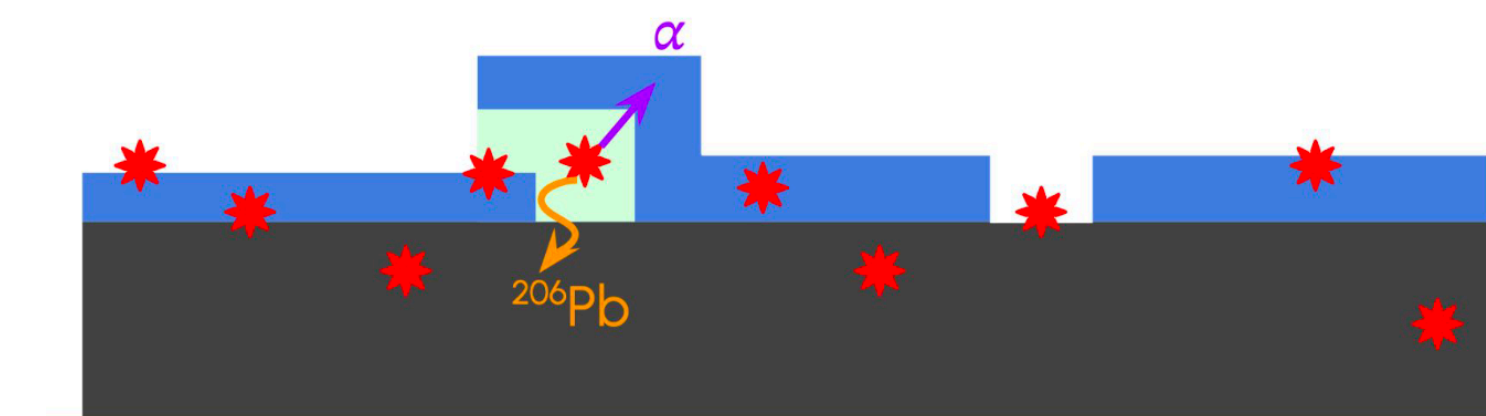

Ta on Sapphire chip fabricated at UChicago



D. Temples poster: “Effects of Radon Progeny in Superconducting Qubits”

K. Anyang poster: “Superconducting Qubit-Based Detector For Dark Matter Search And Radiation Sensing”

Qubit optimization

- AB tests for IR shielding, thermalization, and filtering for readout optimization
- Block IR photon leakage into qubits with a broadband stub-filter packaging

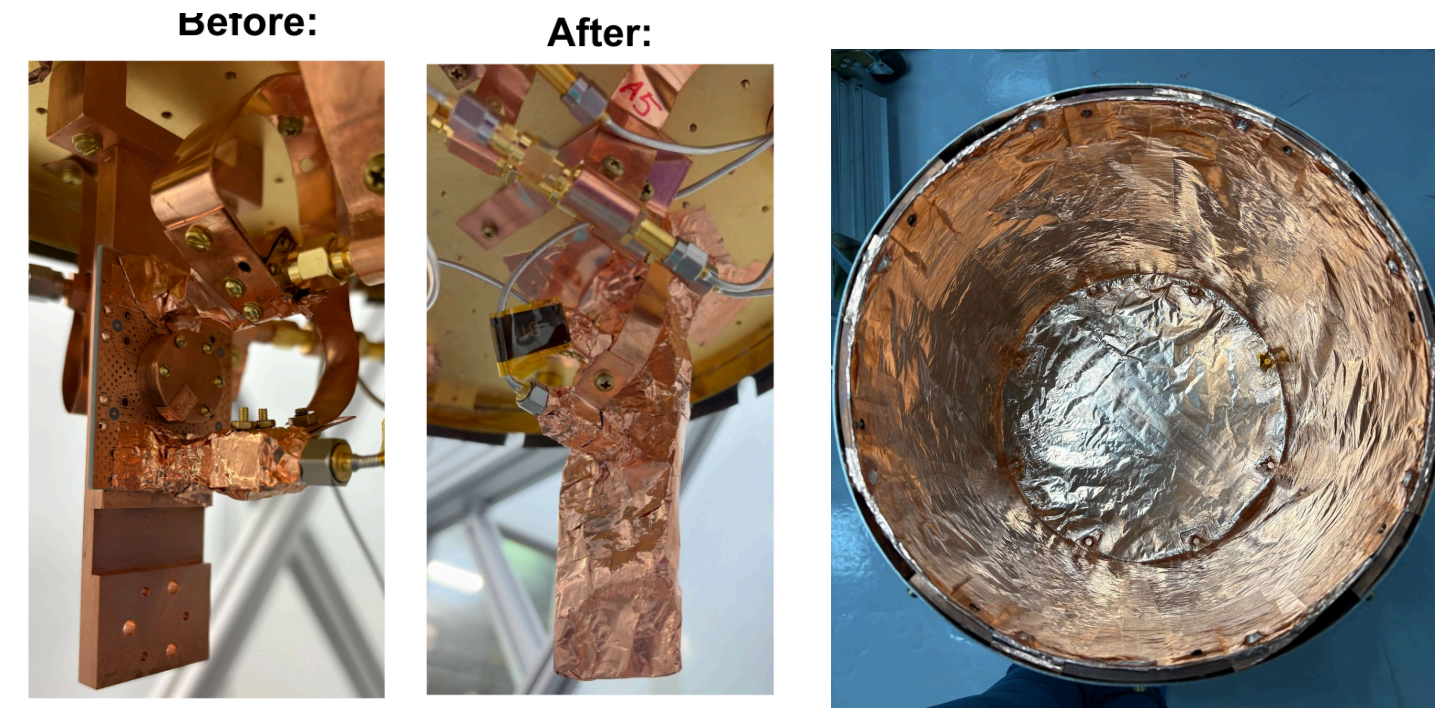
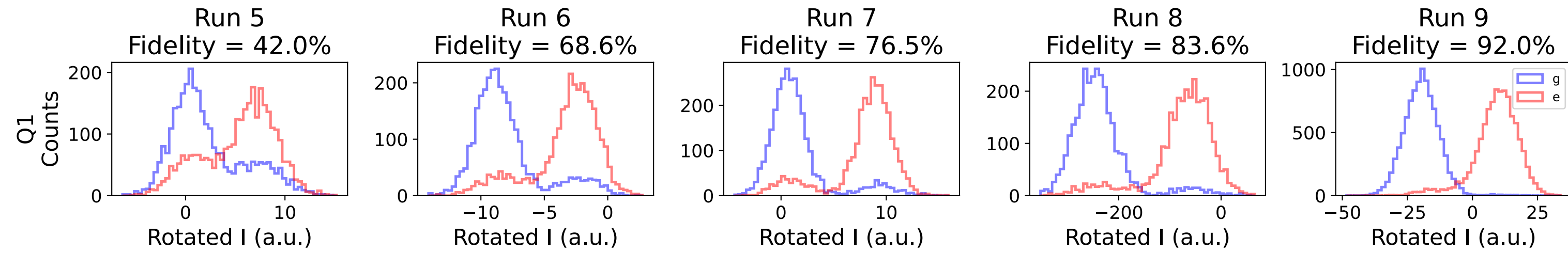
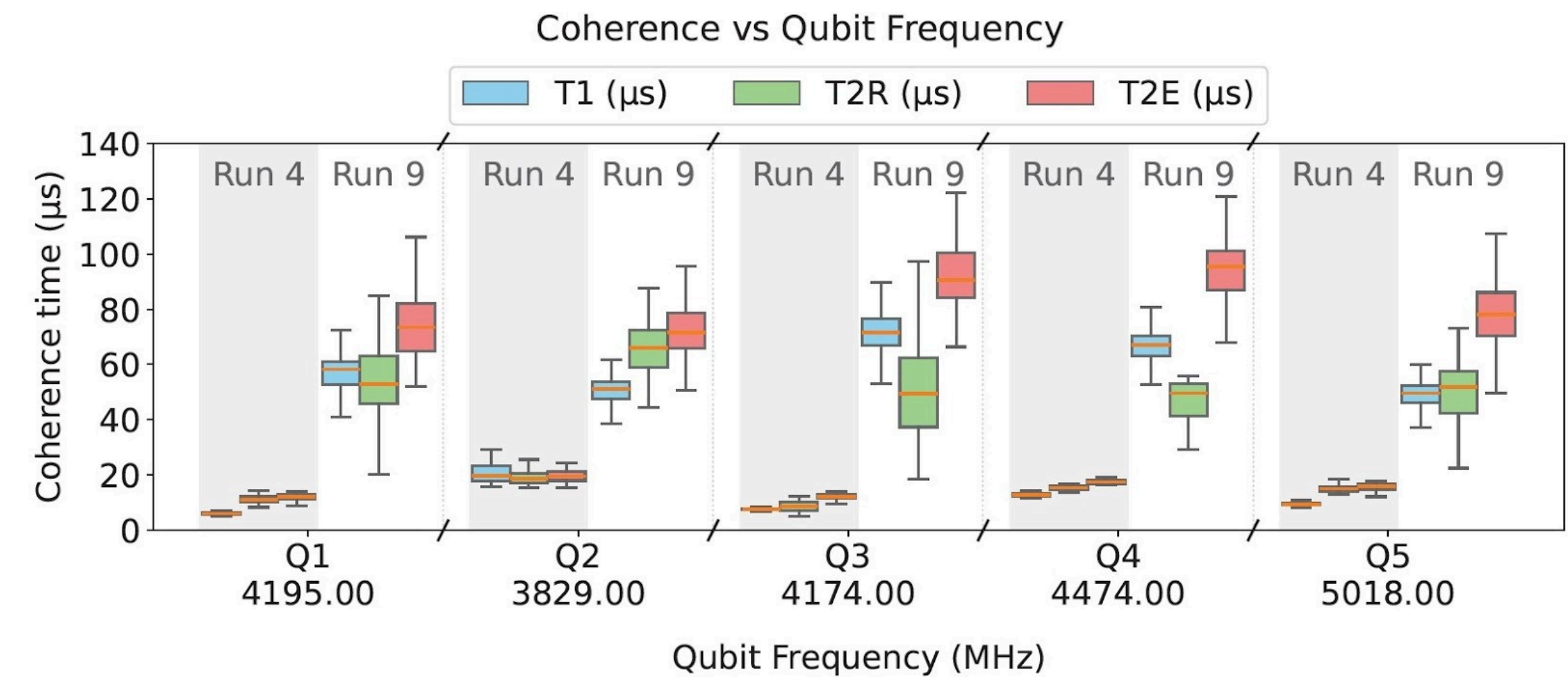
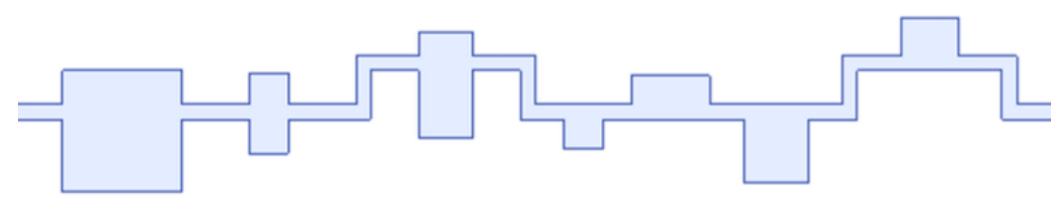
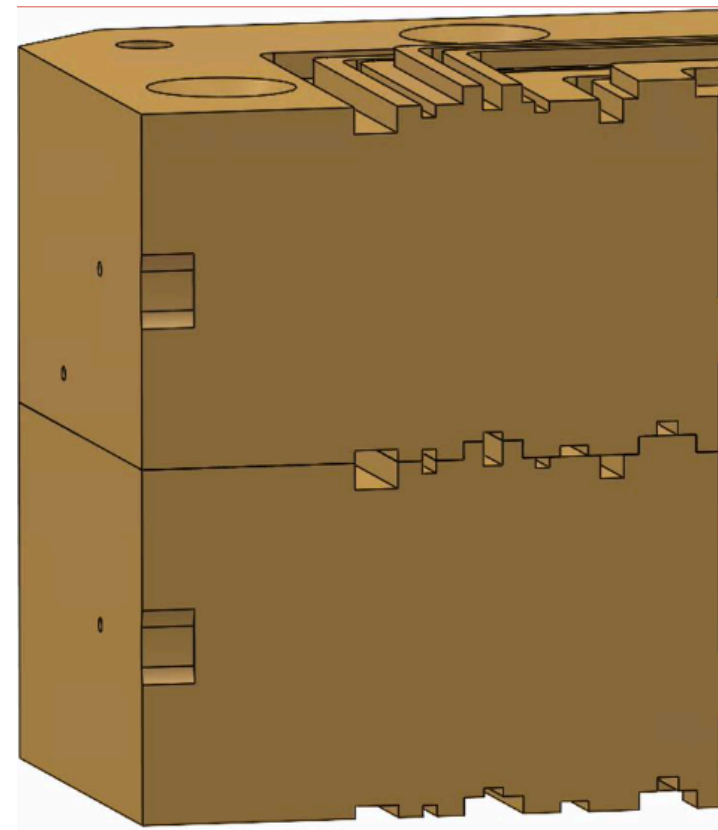
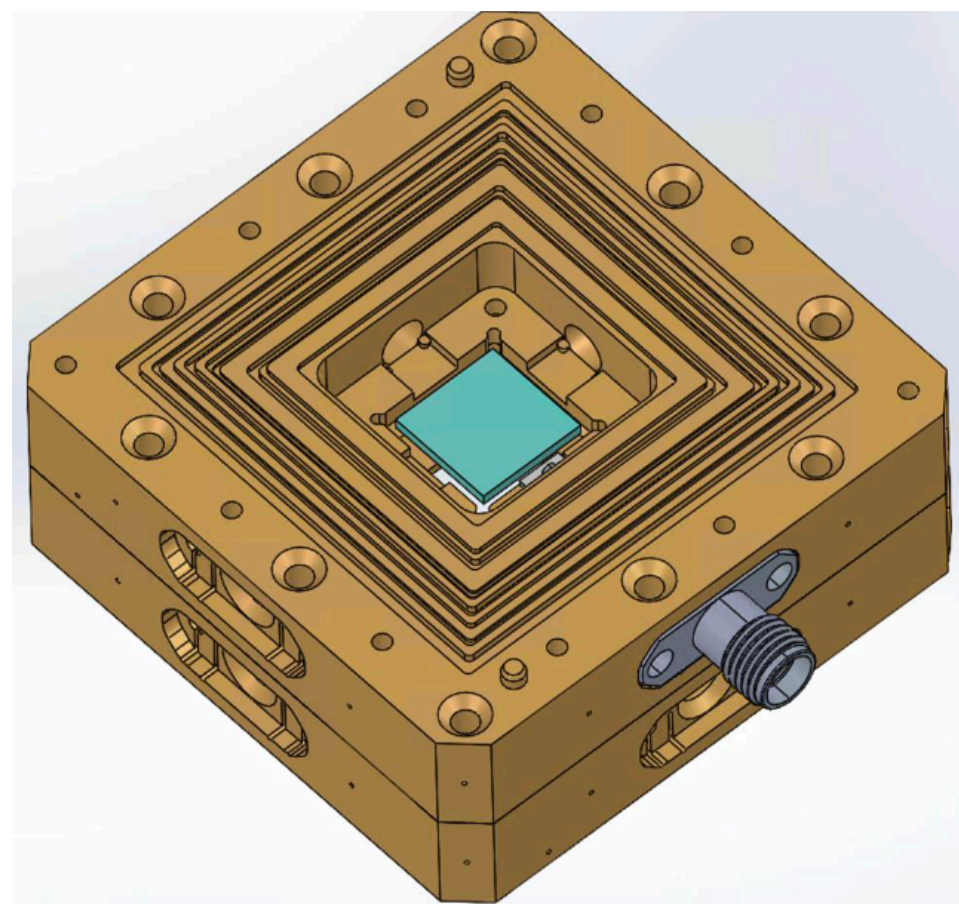

A. Colon Cesani poster: “Effects of Shielding and Filtering on Qubit Coherence and Effective Temperatures at QUIET”

D. Molenaar poster: “Package design to filter GHz to THz photons for superconducting qubits”

QICKlab development

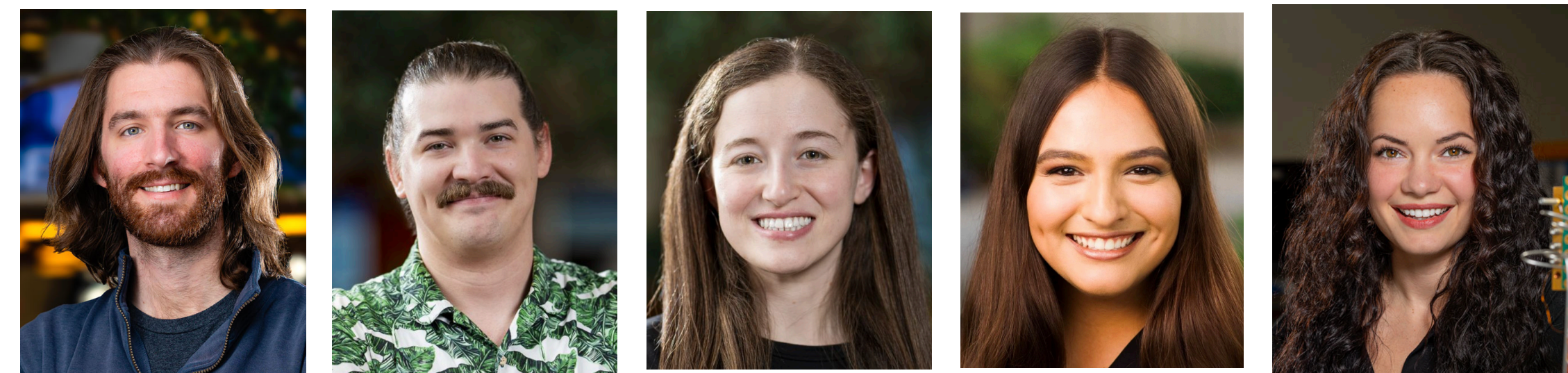

Open source data acquisition codebase developed for QICK (Quantum Instrumentation Control Kit).
Several features for qubit checkout already implemented

+ others

QICK_Qubit_LabSuite

The qubit analysis and data acquisition codebase for the CosmiQuantum g1 source qubit controller. Specifically for qubit operations at the NEXUS and

Custodians:

- Olivia Seidel (UT Arlington)
- Arianna H. Colon Cesani (Northwestern)
- Joyce Christiansen-Salameh (Cornell)
- Kester Anyang (IIT)
- Sara Sussman (FNAL)
- Dylan Temples (FNAL)
- Ryan Linehan (FNAL)

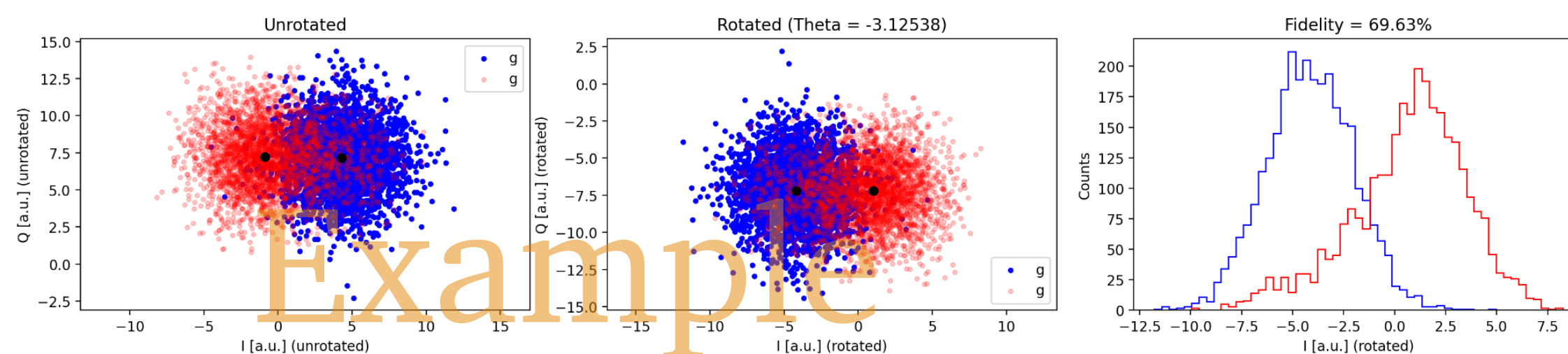
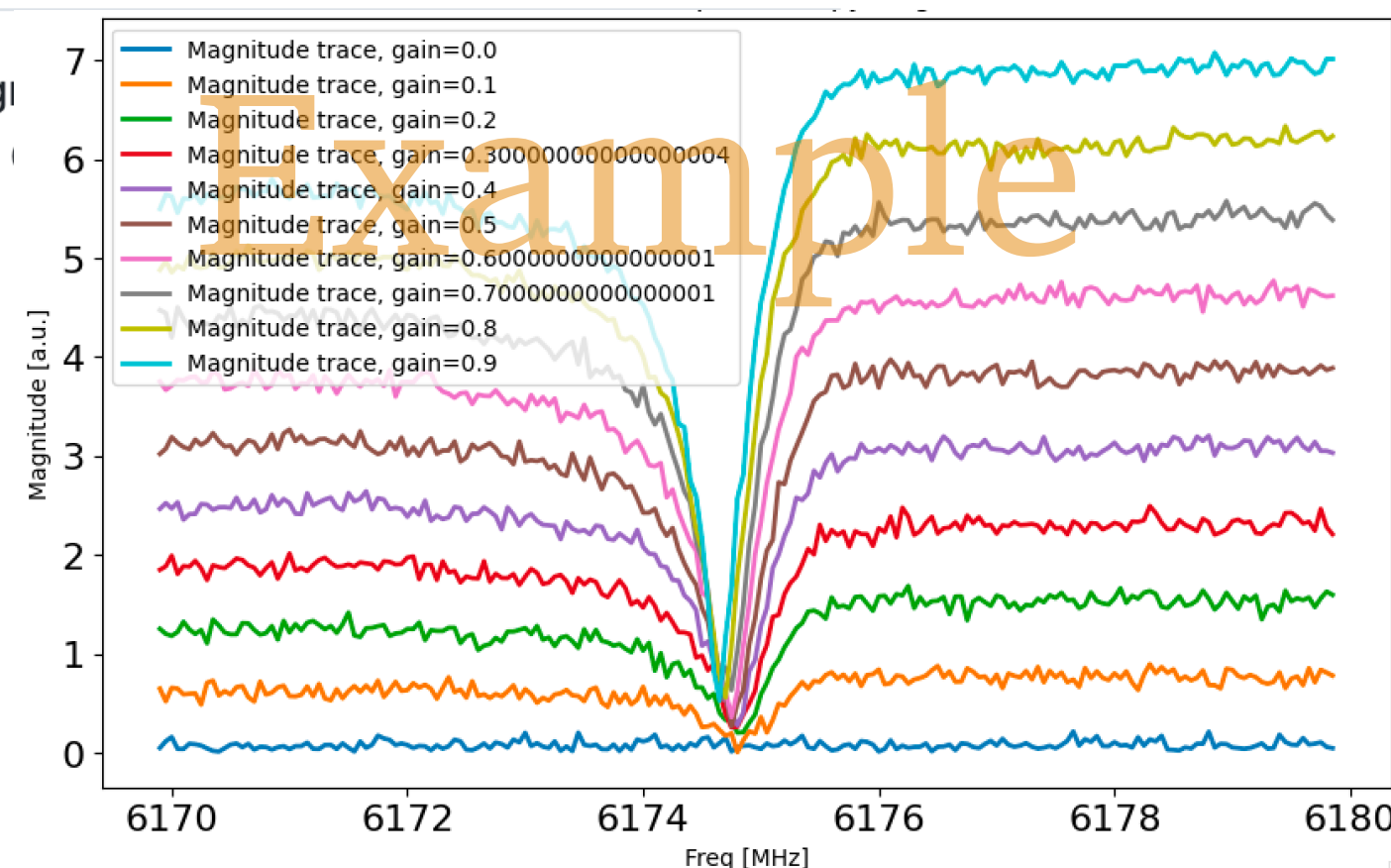

QICK → standalone open source control system for quantum information science

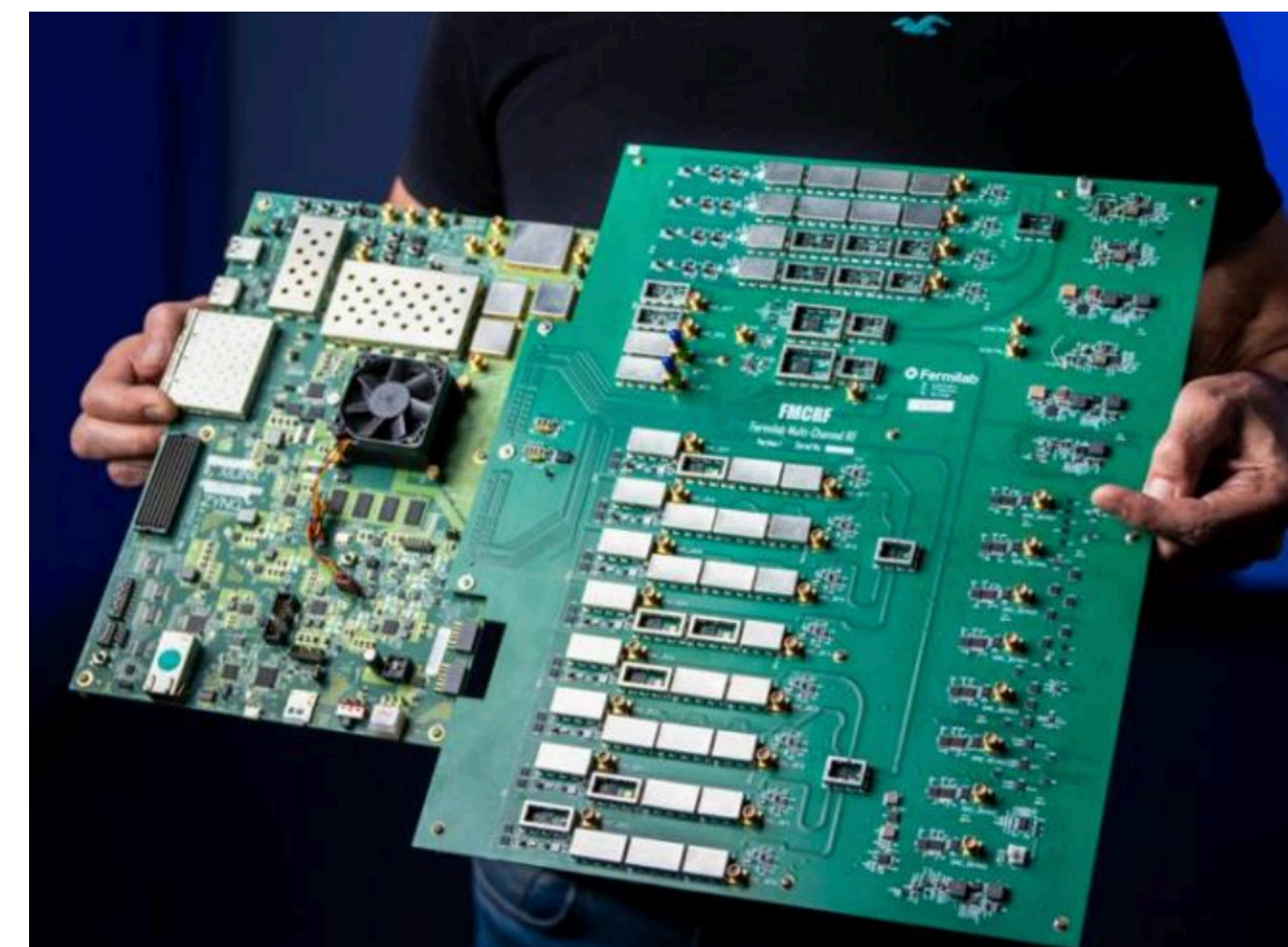

Charge sensitive qubits

- Trapped charges change the electric field environment → charge jumps in charge-sensitive qubits.
- In a previous measurement we found an excess charge jump rate not explained by cosmic rays or radioactivity → understanding long term effects of intense radioactivity on charge environment
- Testing SQUAT in low background environment (See H. Magoon's talk)

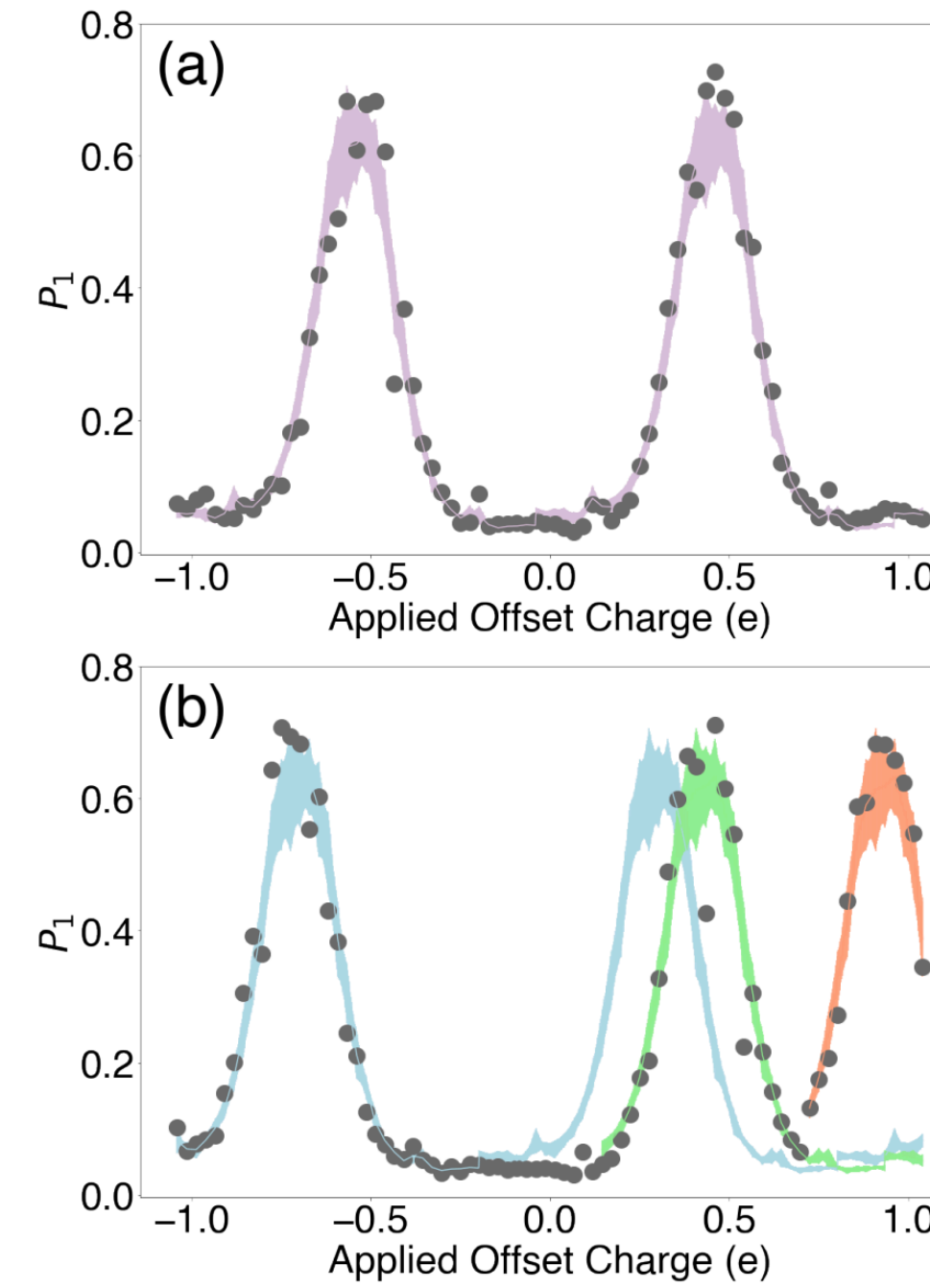

[G. Bratrud et al. \(2024\)](#)

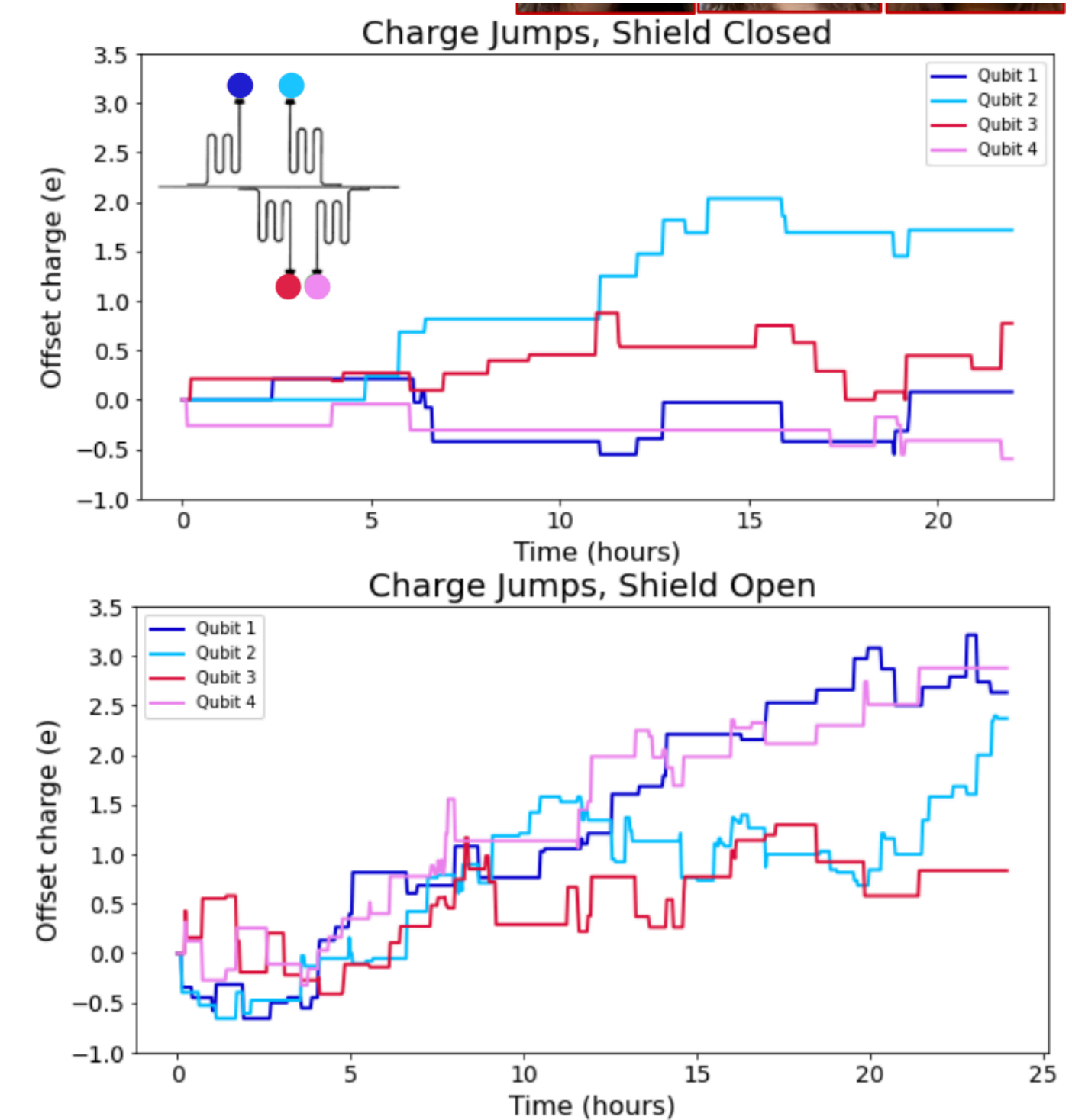
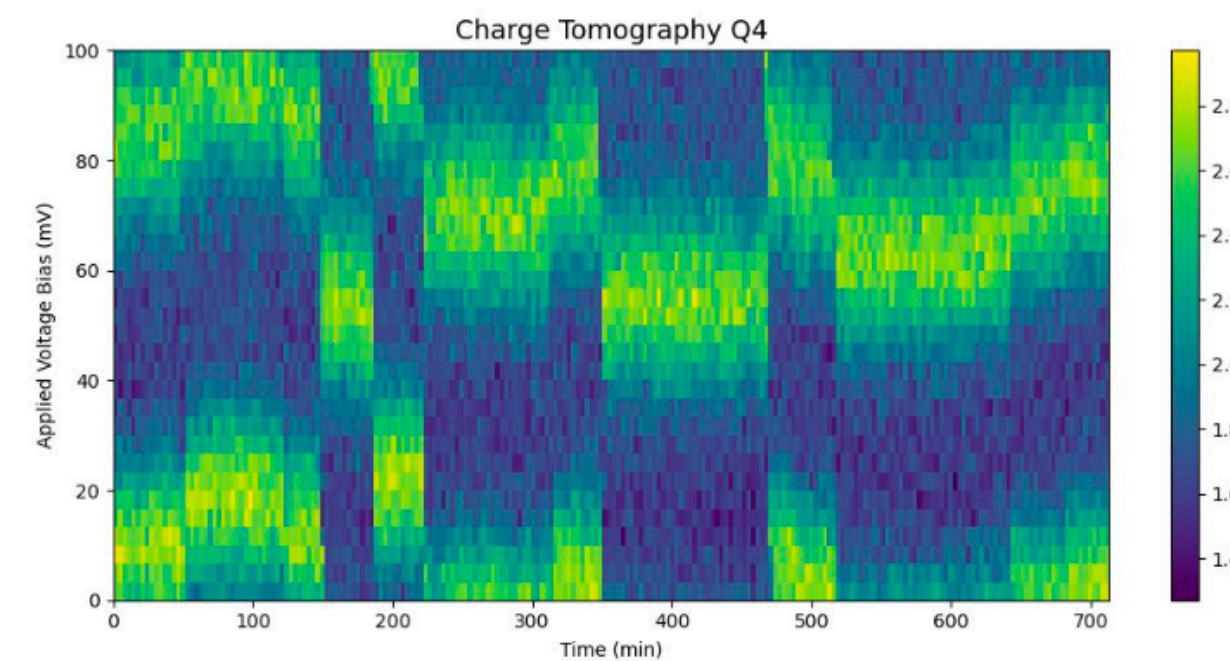

G. Bratrud poster: “Studying ionizing radiation effects on superconducting quantum circuits to optimize quantum sensors for particle detection”

Microphysics modeling in G4CMP

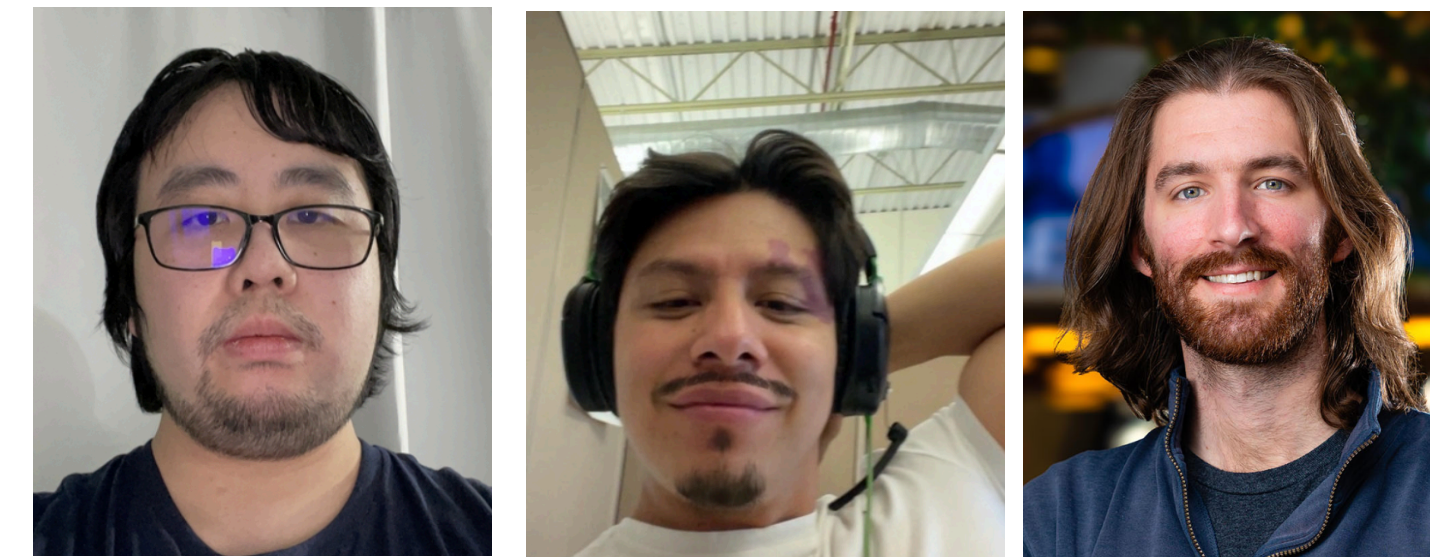

- Active members of the G4CMP consortium
- New materials implementation
- Introduction of new features like charge transport and QP dynamics

[I. Hernandez et al. \(2024\)](#)

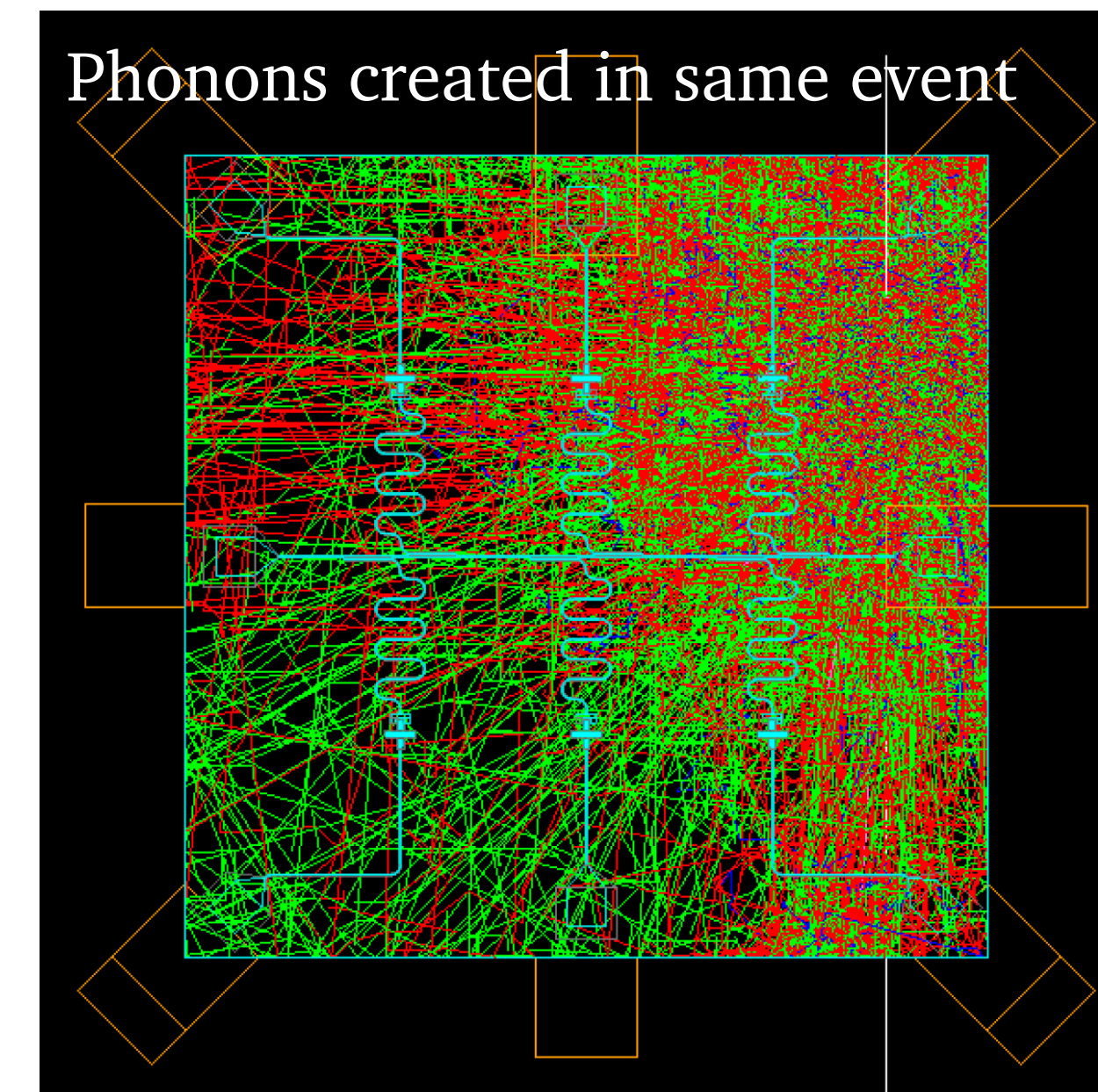
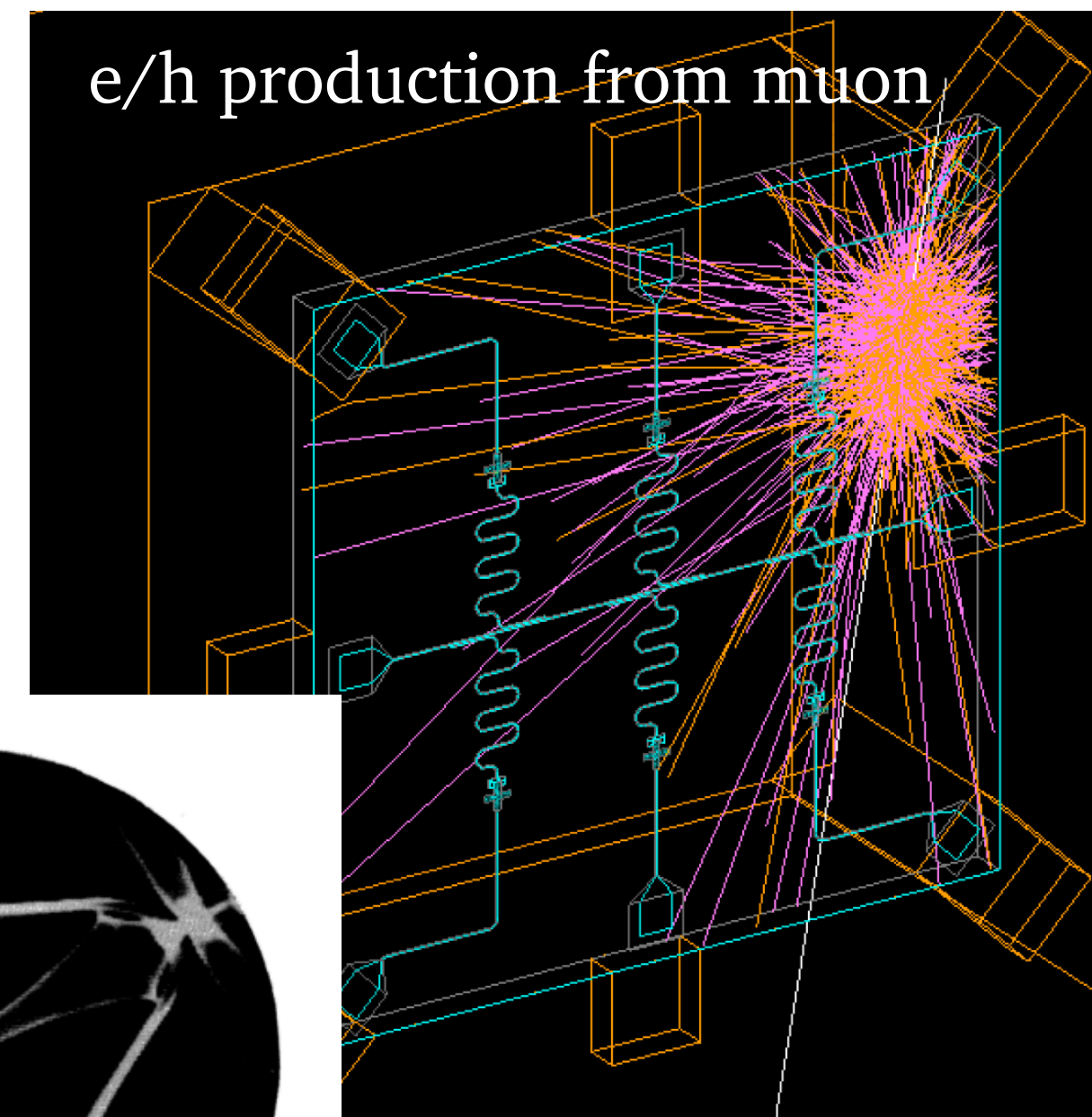
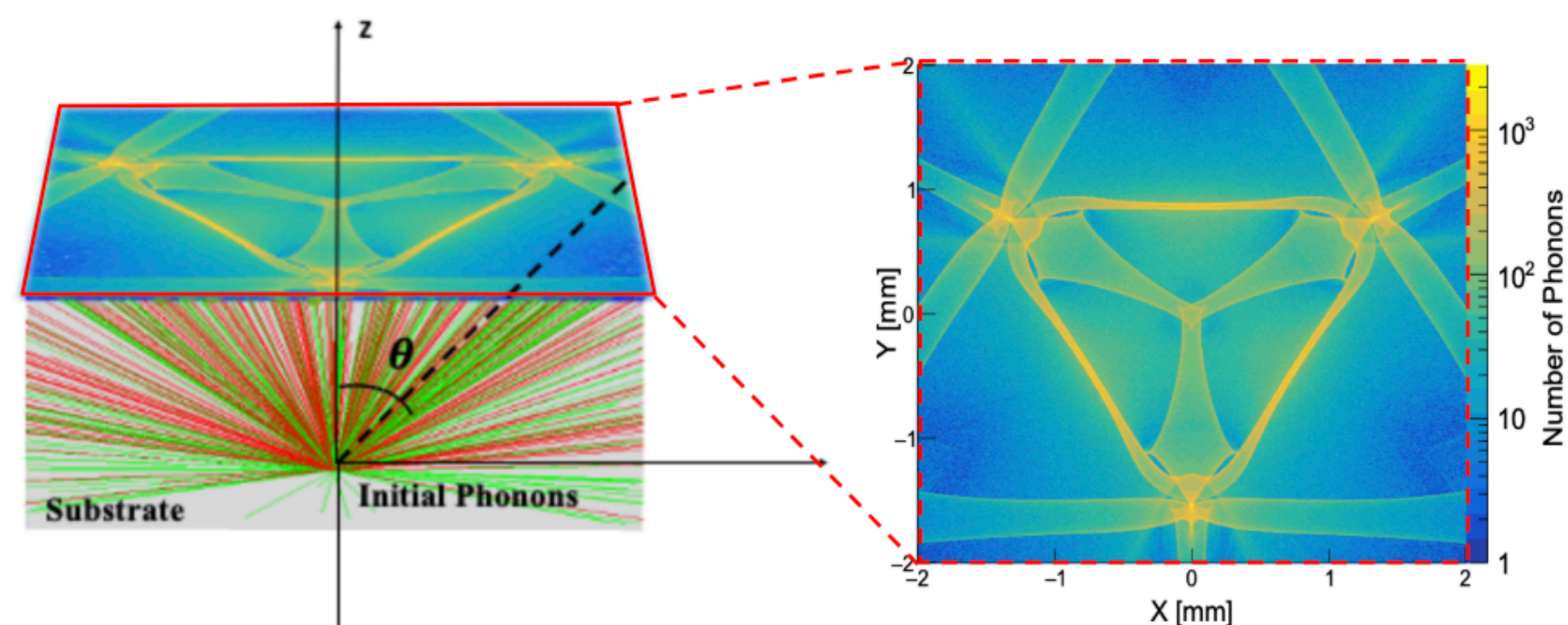

I. Hernandez poster: “Extending G4CMP for Energy Transport in Sapphire and Superfluid Helium”

Z. Cai poster: “G4CMP for Modeling Athermal Phonons in Superconducting Qubit Detectors”

+ see R. Linehan and I. Hernandez contributions at G4CMP workshop

Quantum acoustic devices



Quantum acoustics: piezoelectric coupling between high-overtone bulk acoustic resonator (hBAR) and superconducting qubit.

→ promising technology for Dark Matter and Coherent Elastic Neutrino Nucleus Scattering (CEνNS) detection

→ need for phonon downconverters to reduce phonon energy to match acoustic resonance

→ test ongoing with low gap superconductors (AlMn)

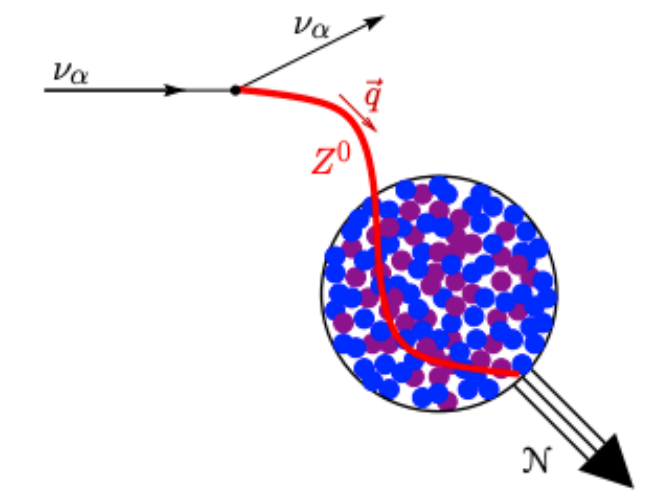

Elastic coherent (CEνNS)
 $\lambda_{z^0} \gtrsim 2R$

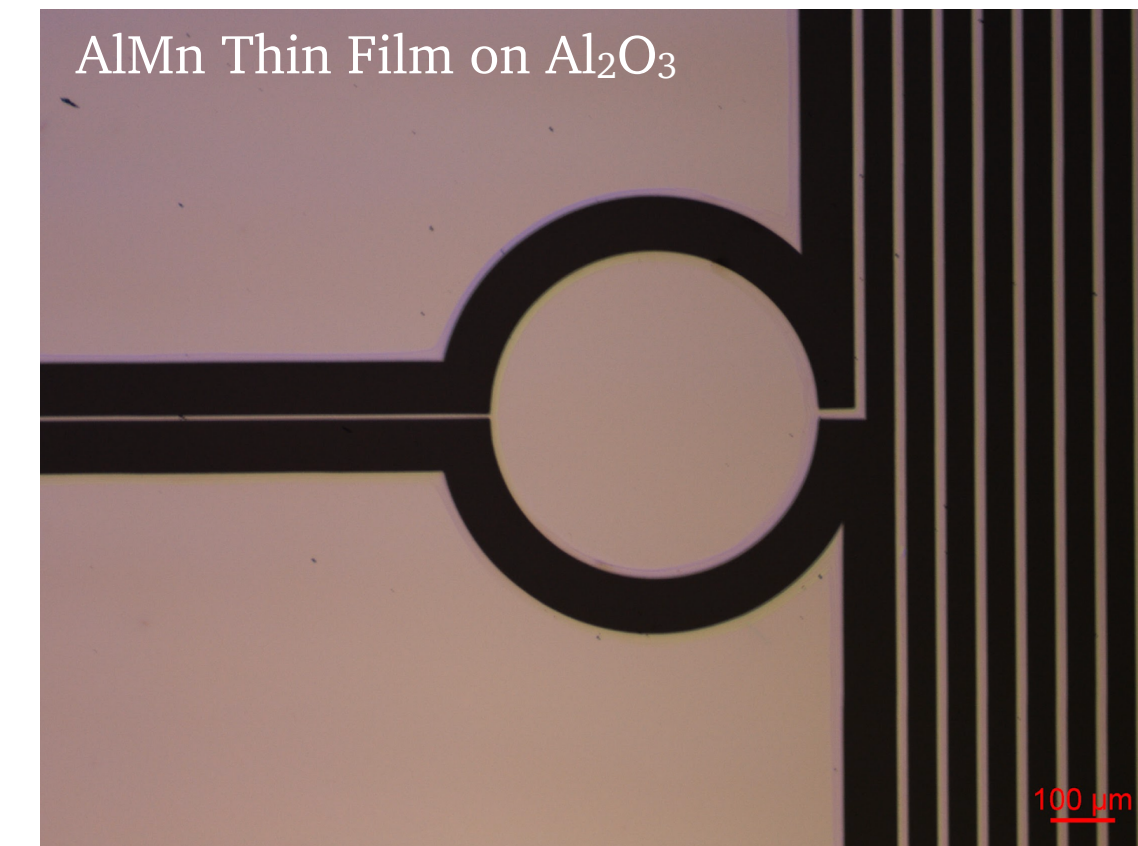
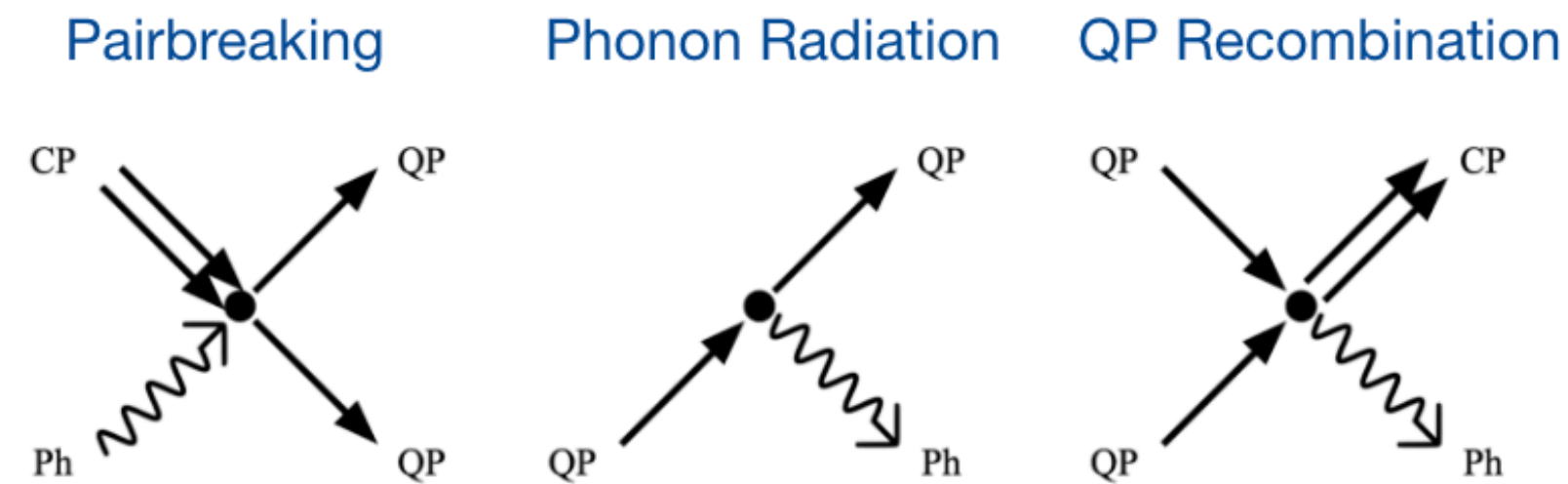
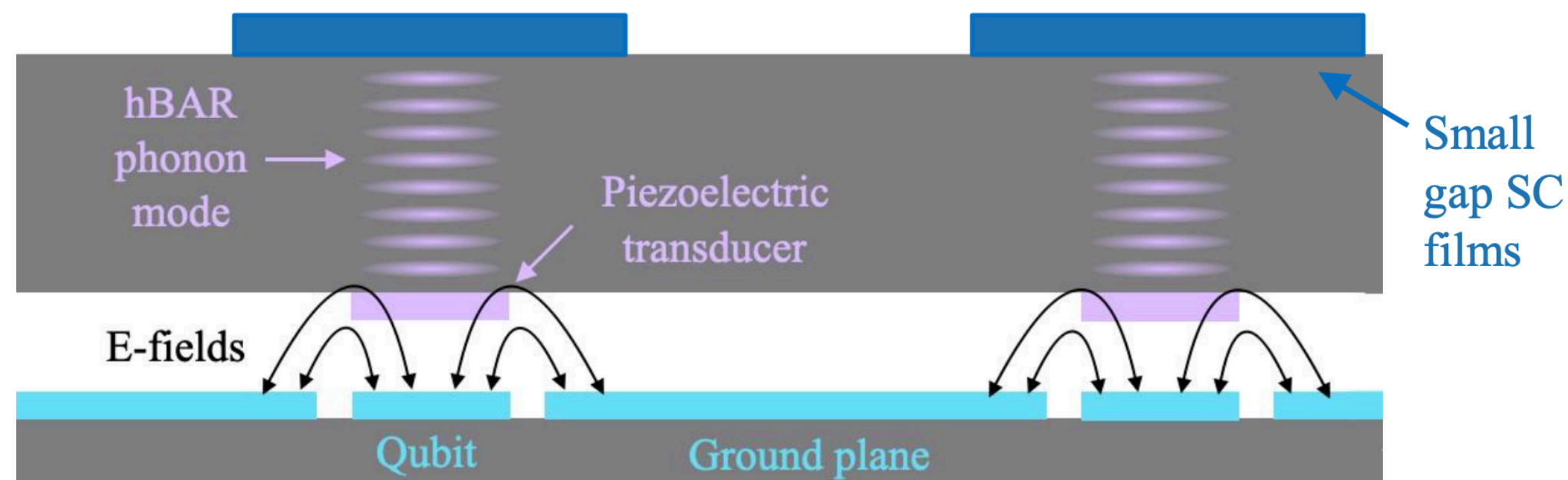

A. Rodriguez poster: “Gap Engineered Superconducting Films and Circuits for Quantum Sensing and Computing”

Thanks for the attention

Backup

Superconducting qubit → anharmonic oscillator

Substitute the inductor with a Josephson Junction

$$H = 4E_C n^2 - E_J \cos(\phi)$$

charge energy

Josephson energy

JJ acts as a non-linear inductor.

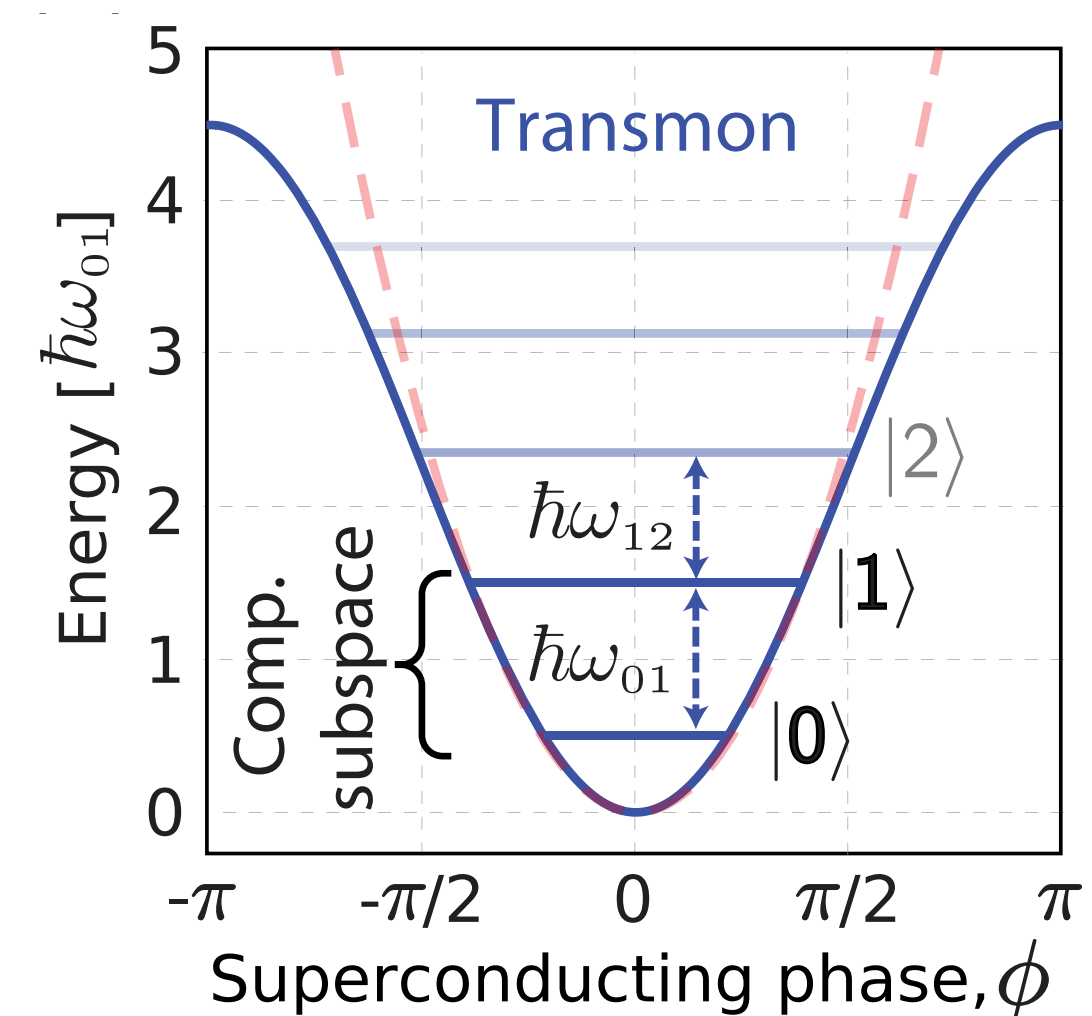
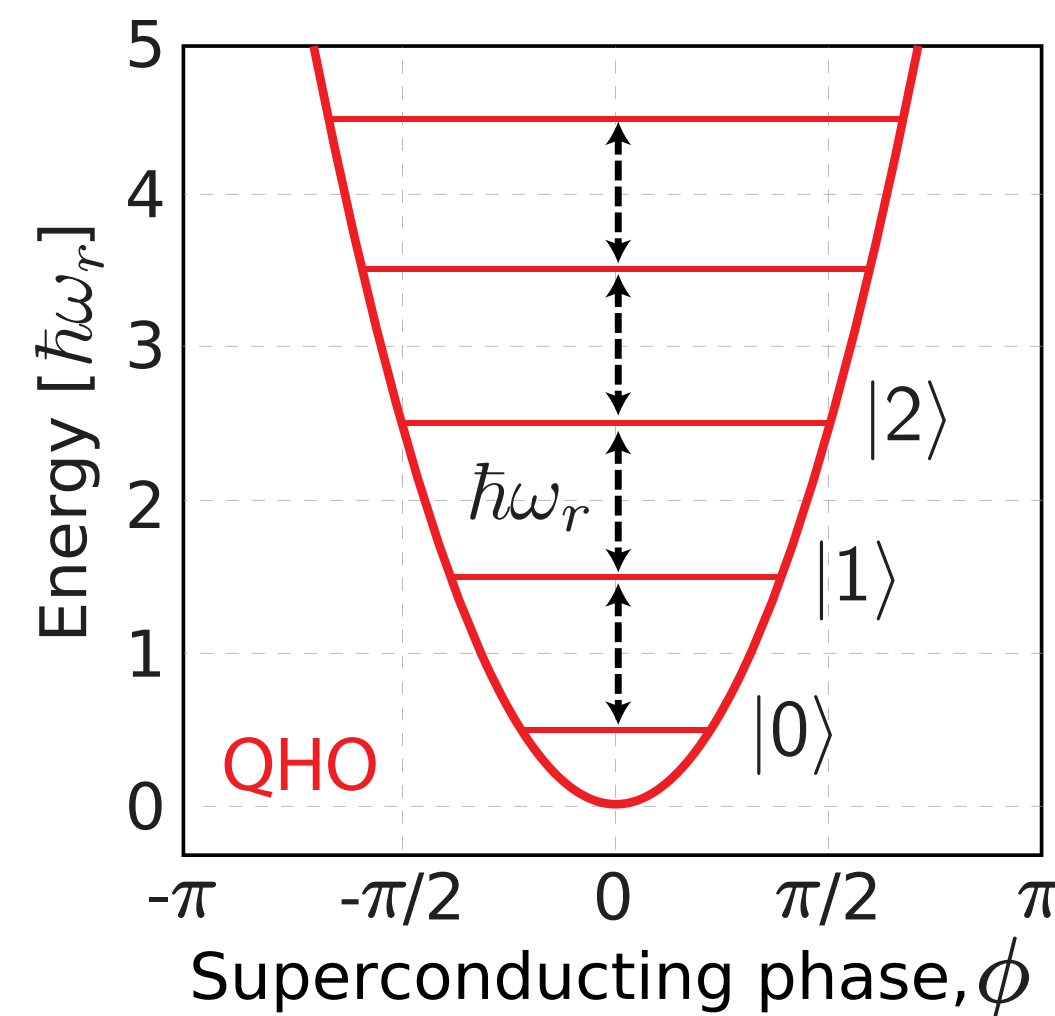
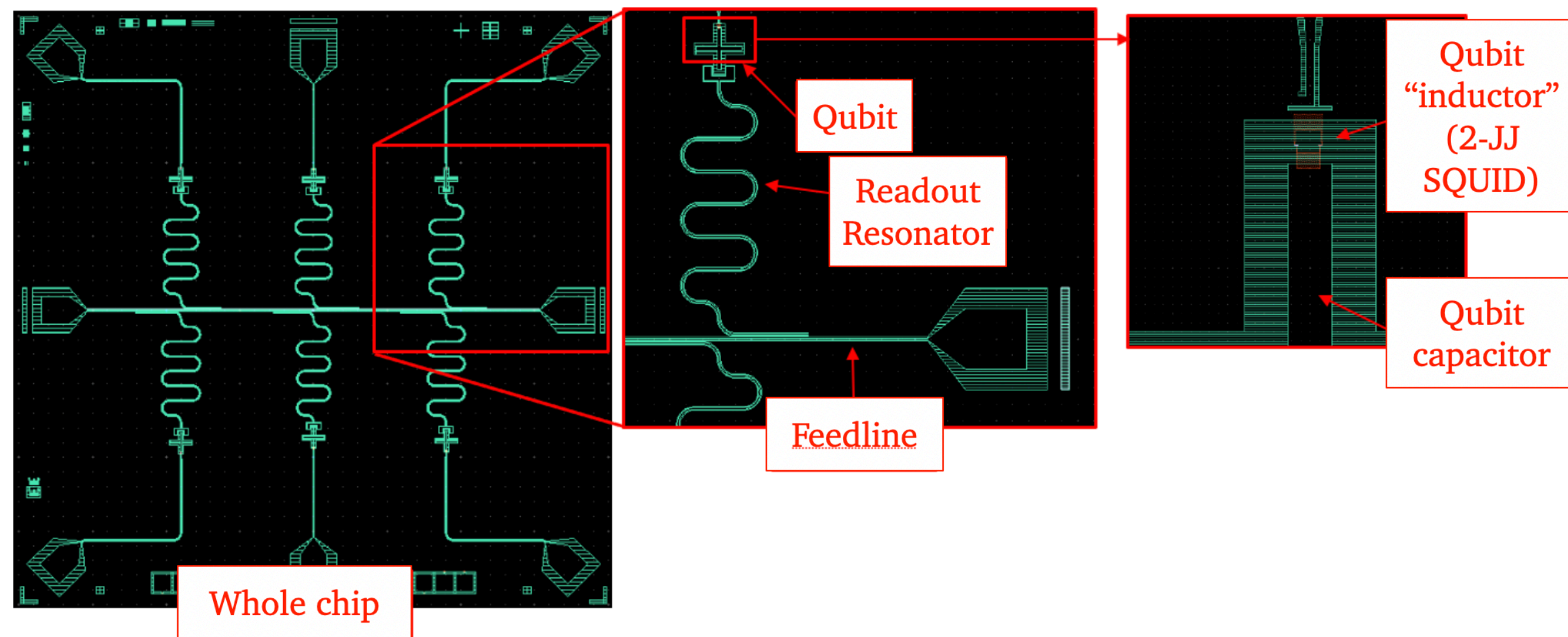
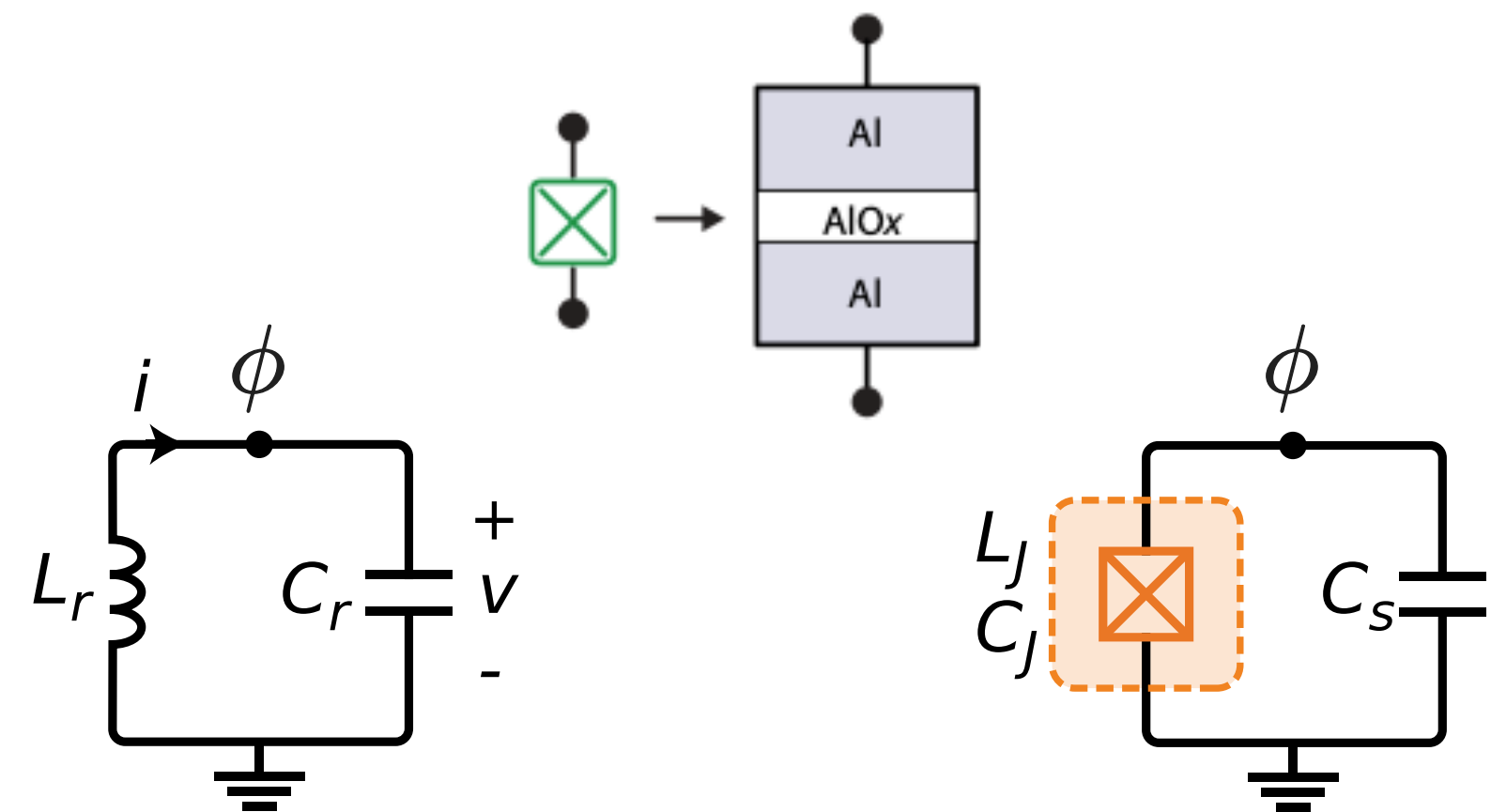

Quasiparticle poisoning

[Google Quantum AI \(2022\)](#)

- ❖ Relaxation \rightarrow loss of qubit state in a T_1 time scale ($|1\rangle \rightarrow |0\rangle$)
- ❖ Athermal phonons produced in the substrate breaks the Cooper pair creating quasiparticles which tunnel through the JJ producing relaxation

$$\Delta = 180 \mu\text{eV for Aluminum}$$

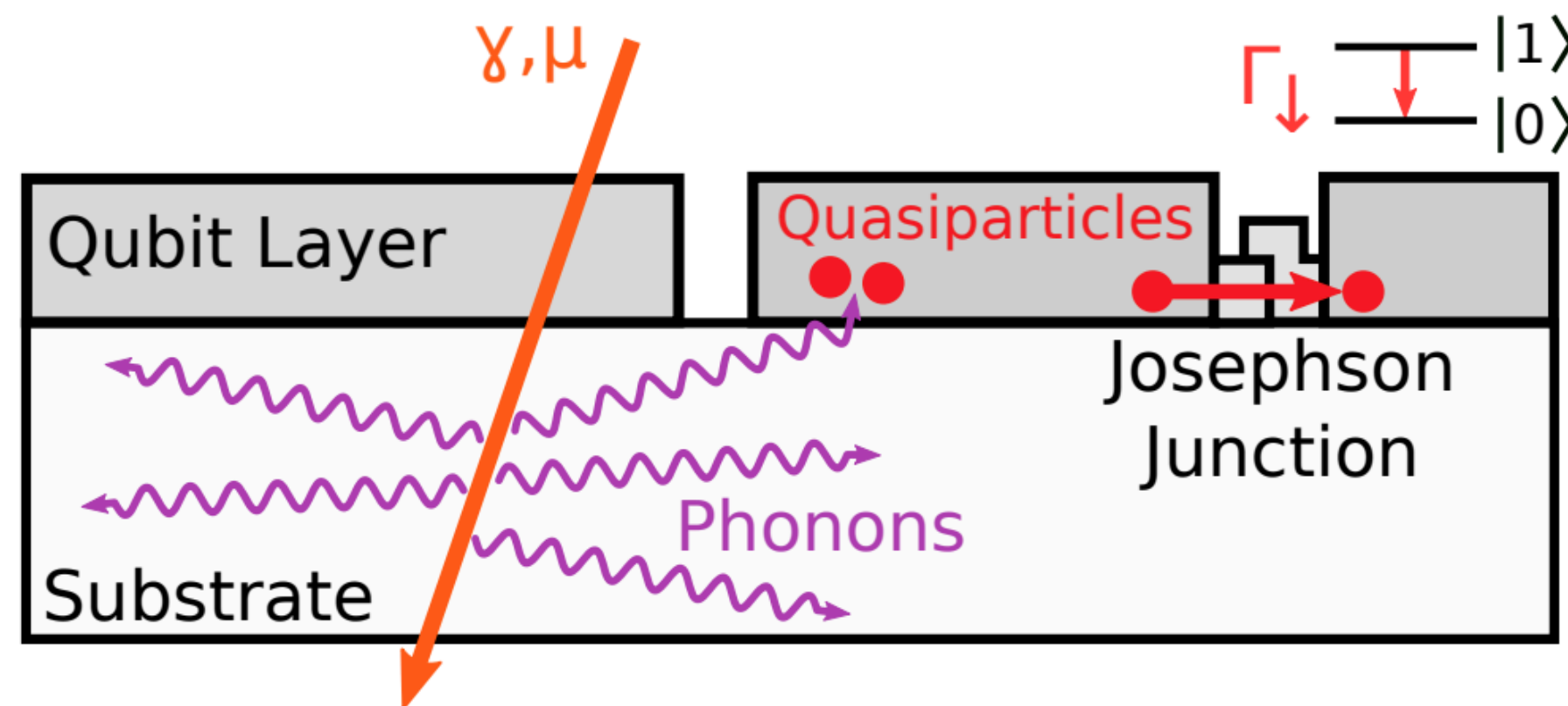

Can we use qubits as low temperature detectors for measuring particles depositing energy in the substrate?

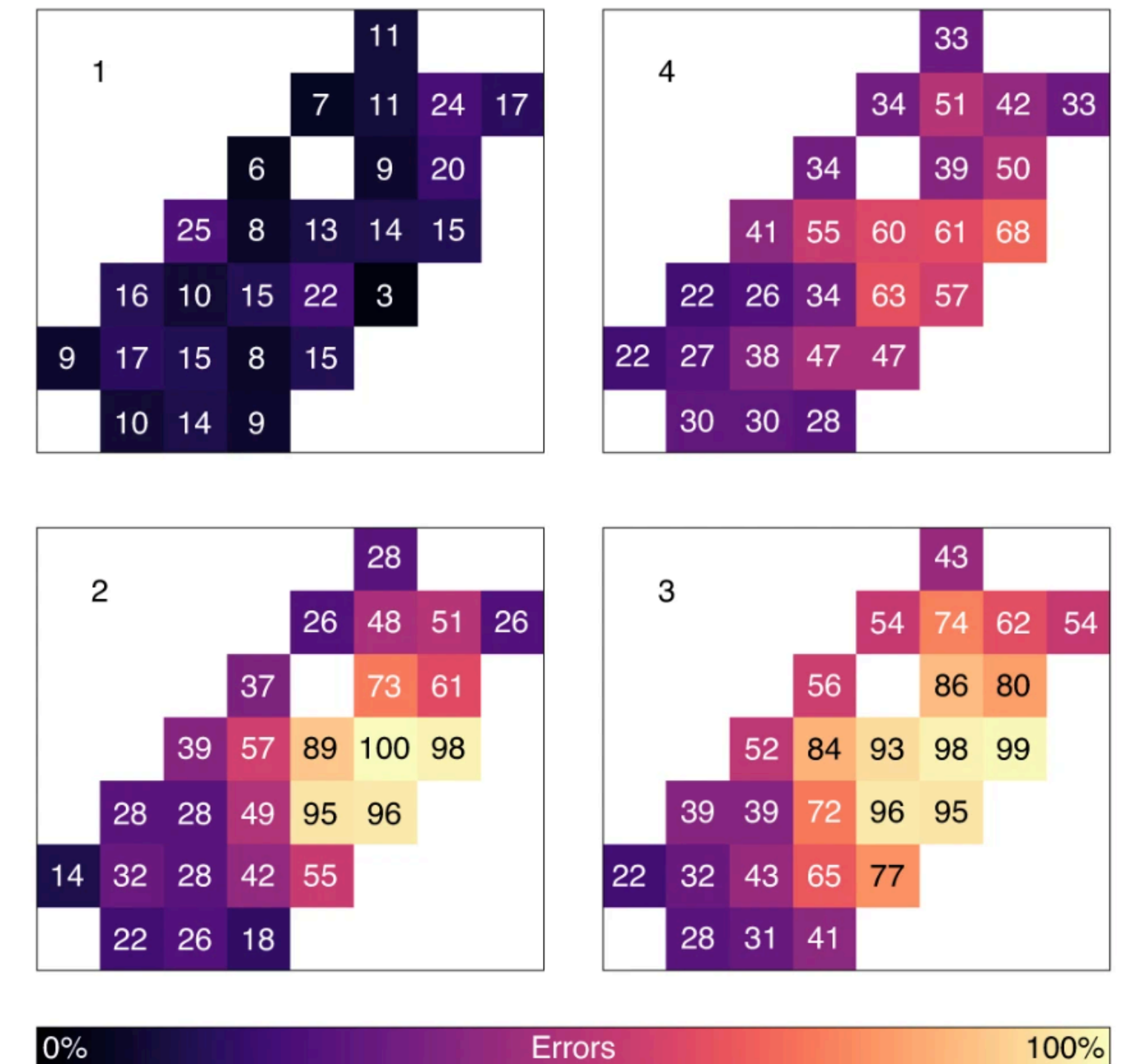
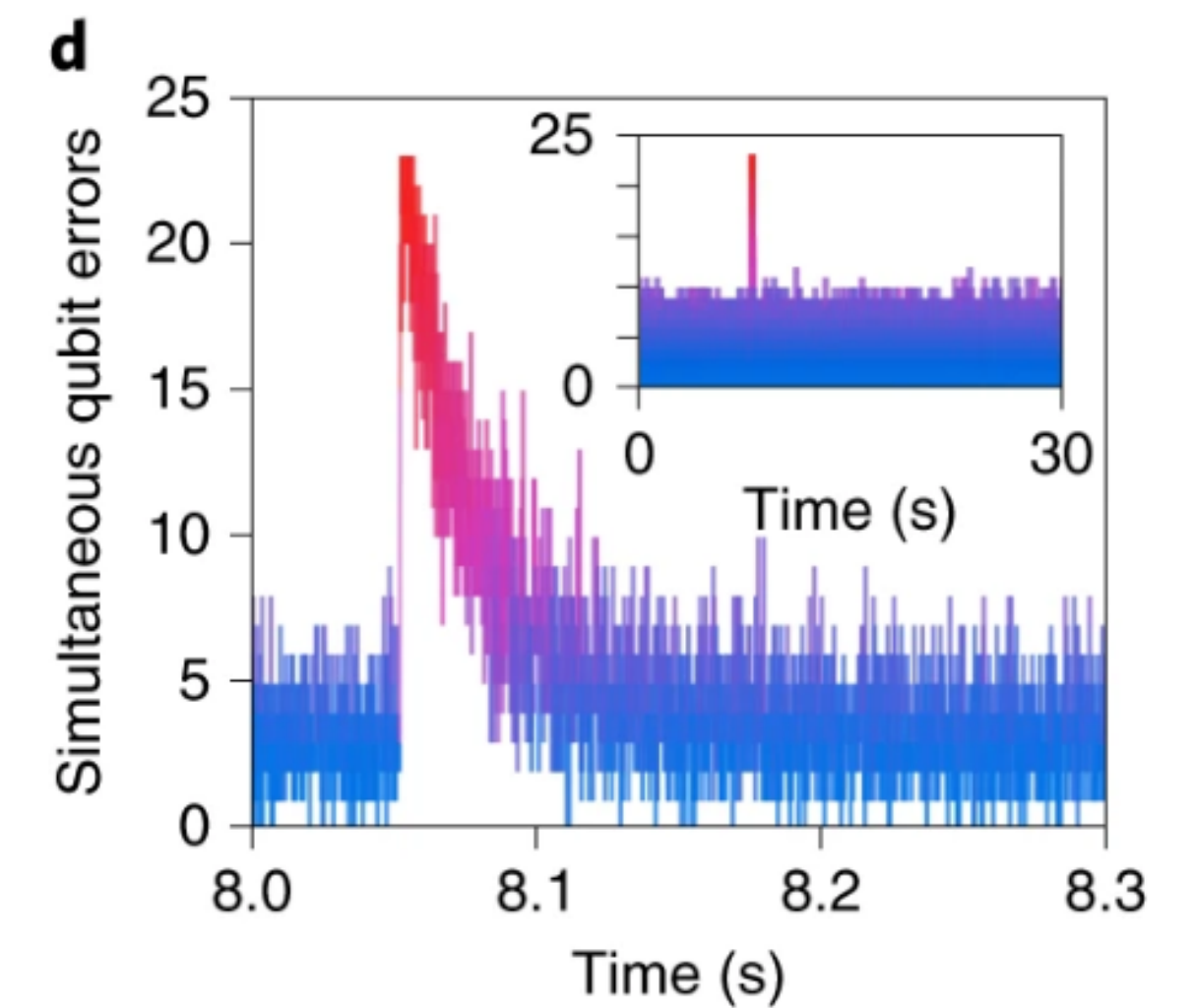

Fabrication

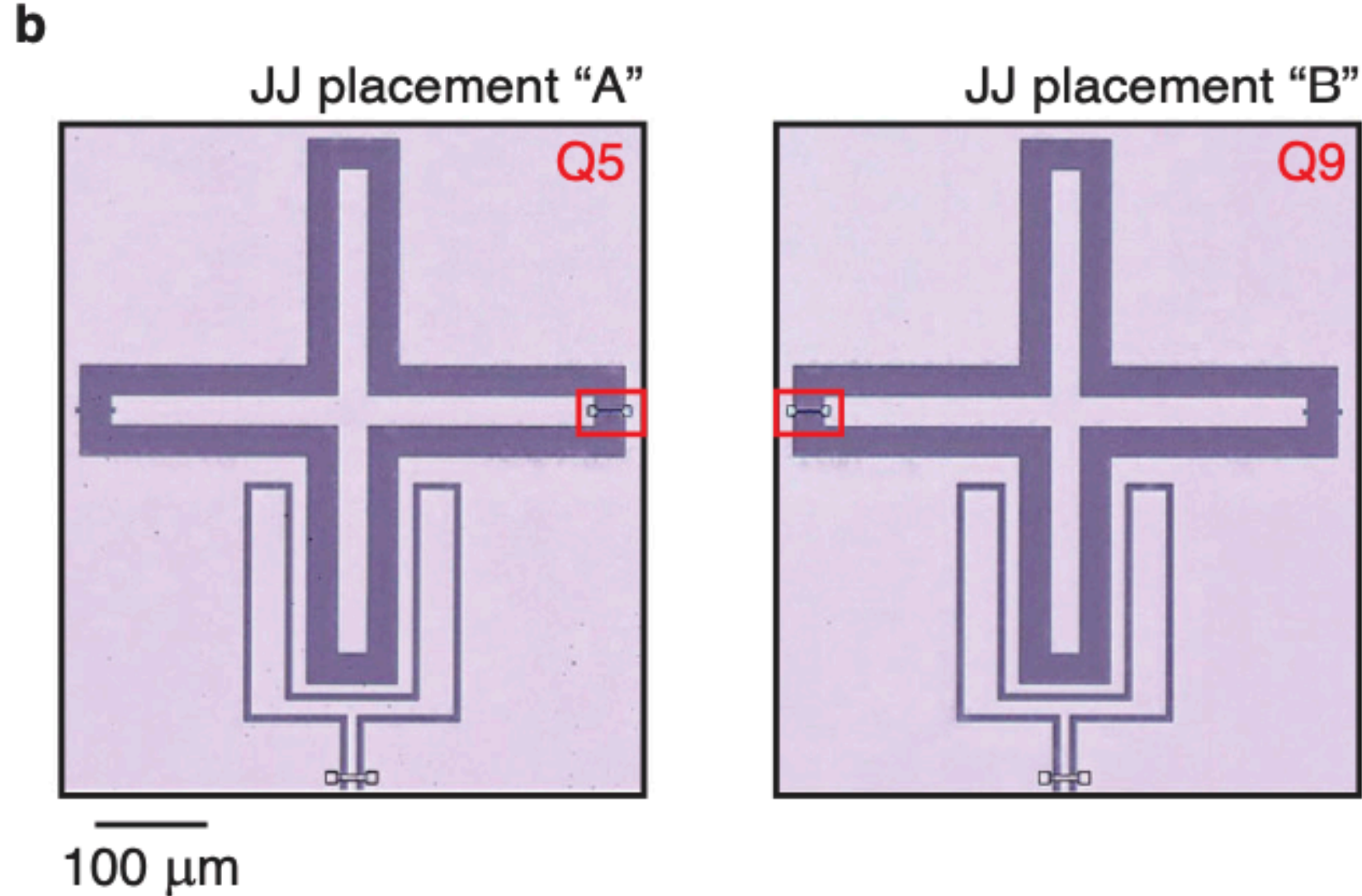

[Harrington et al, \(2024\)](#)

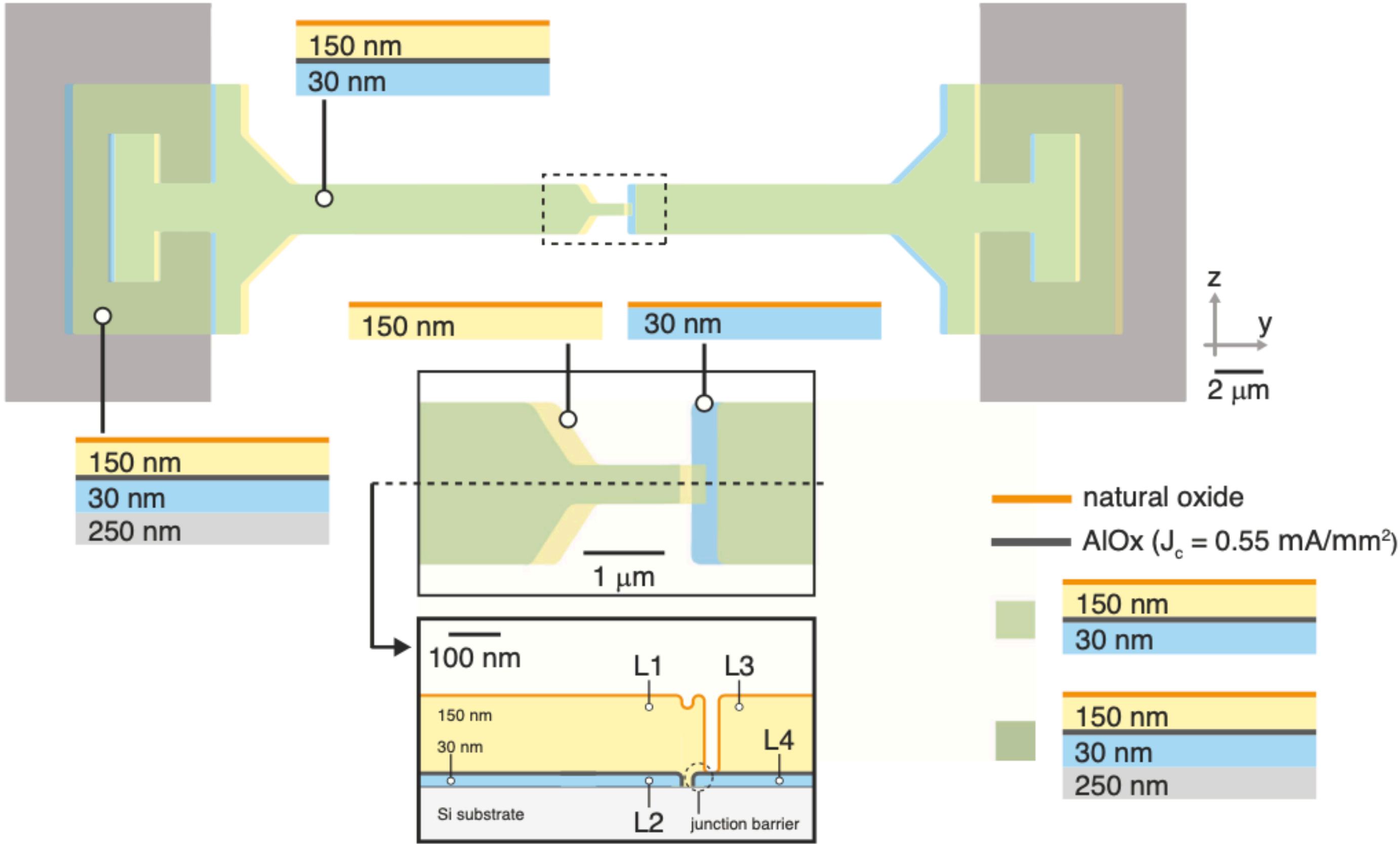

Pulse sequence

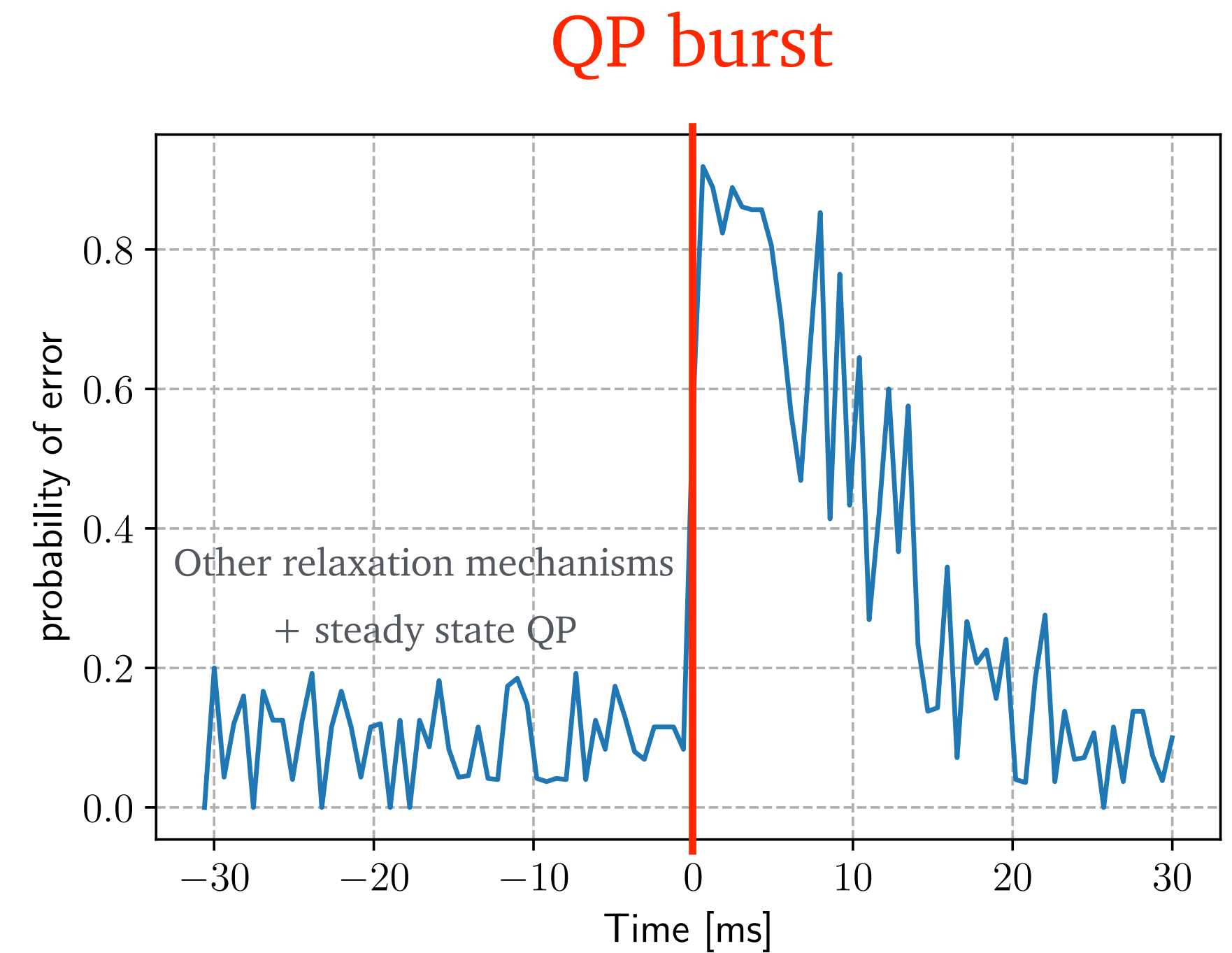
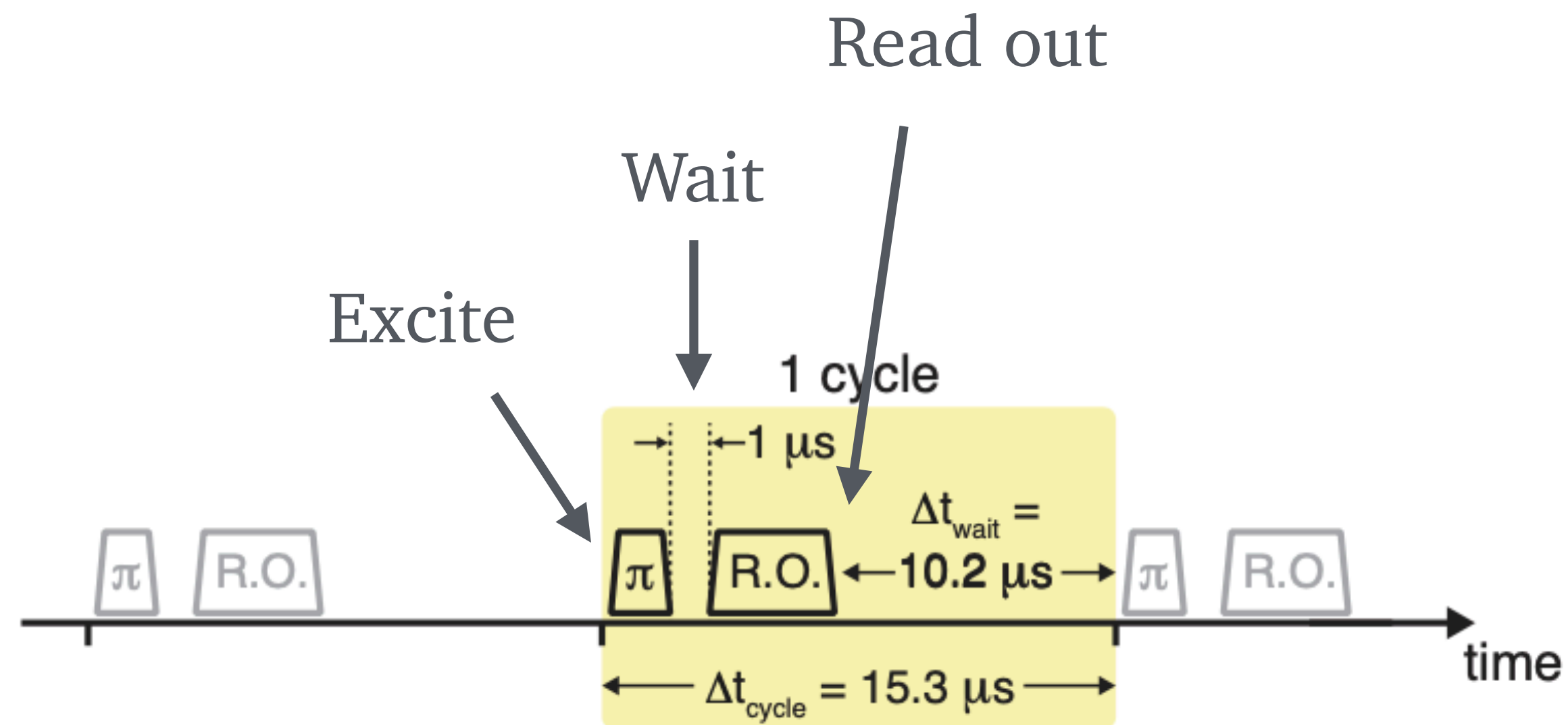

Prob of error = #of errors/#of measurements

Bin \rightarrow set of 40 measurements

Measurement and trigger

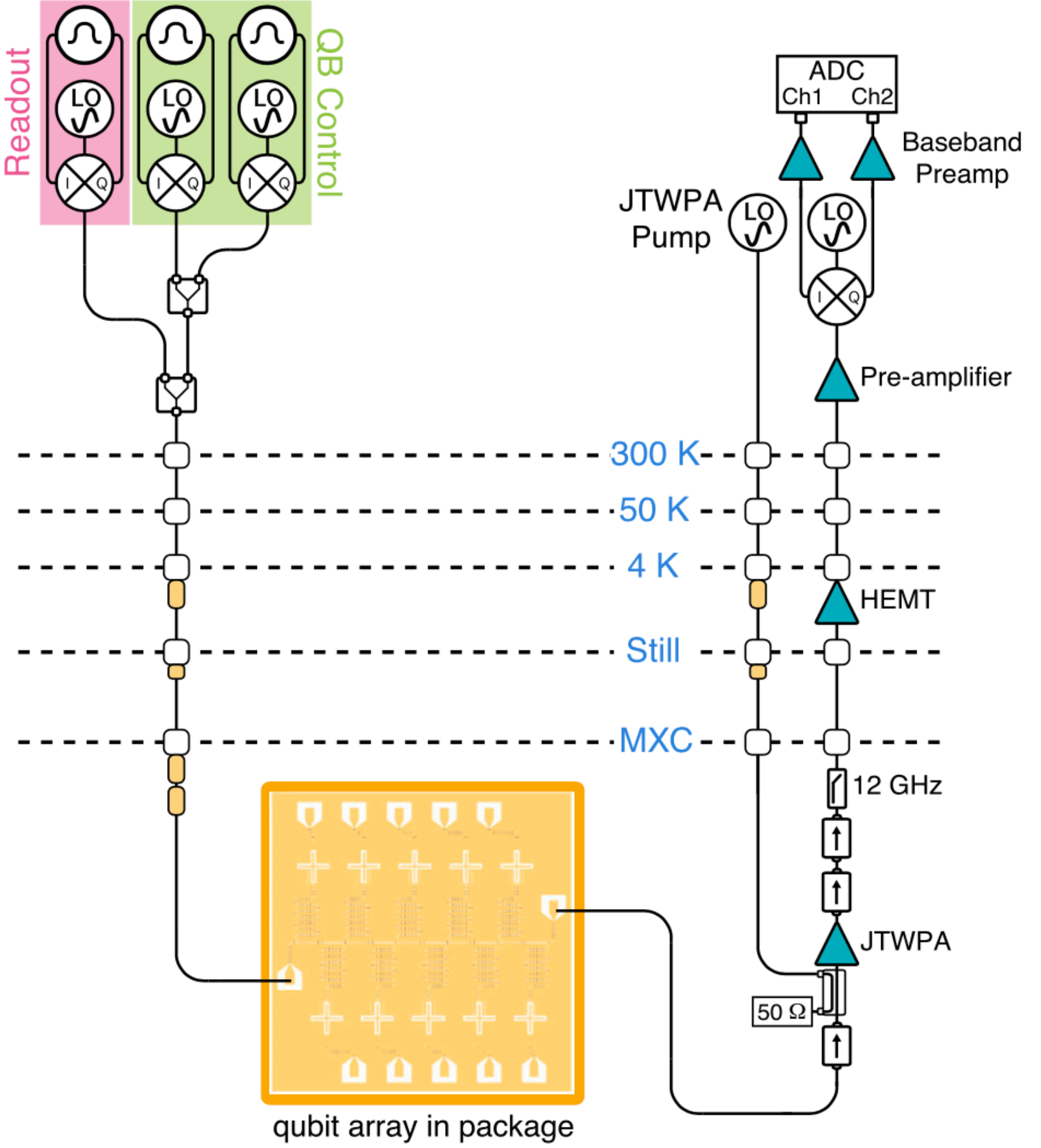
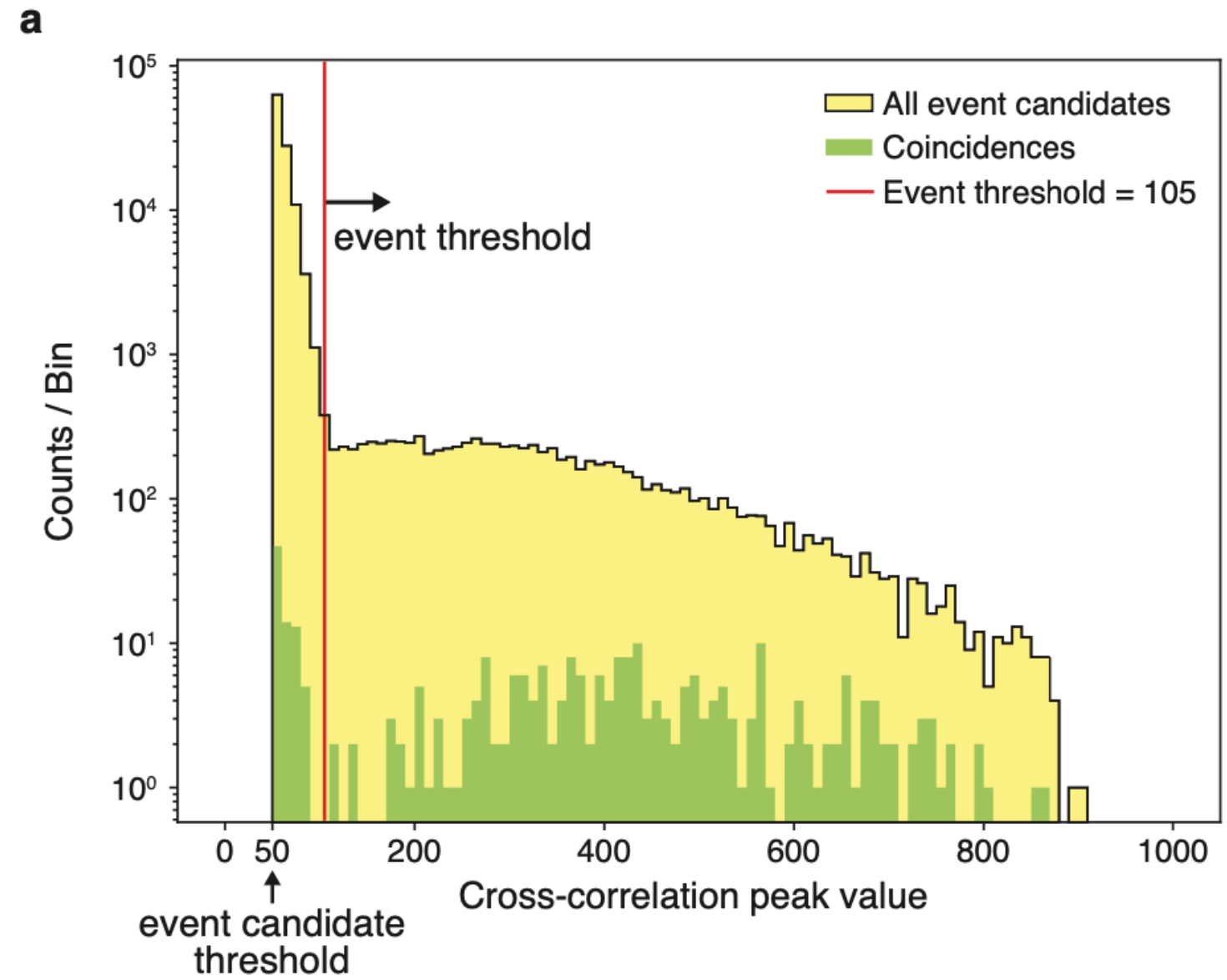
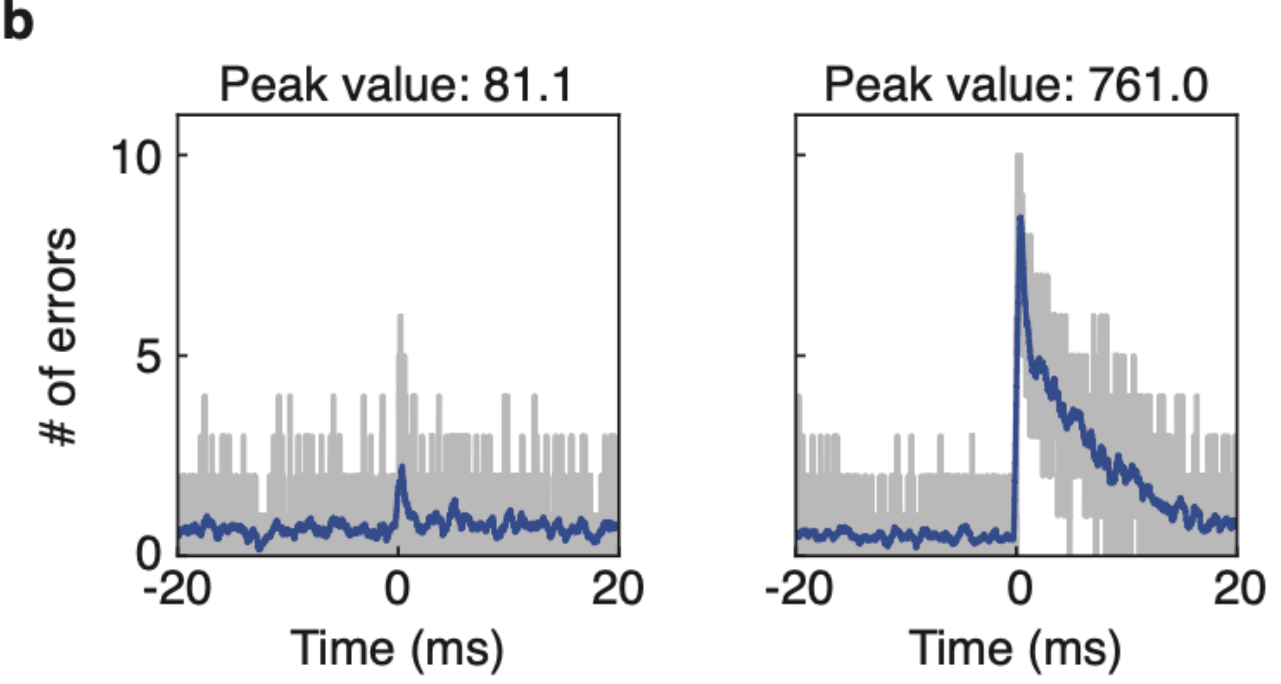
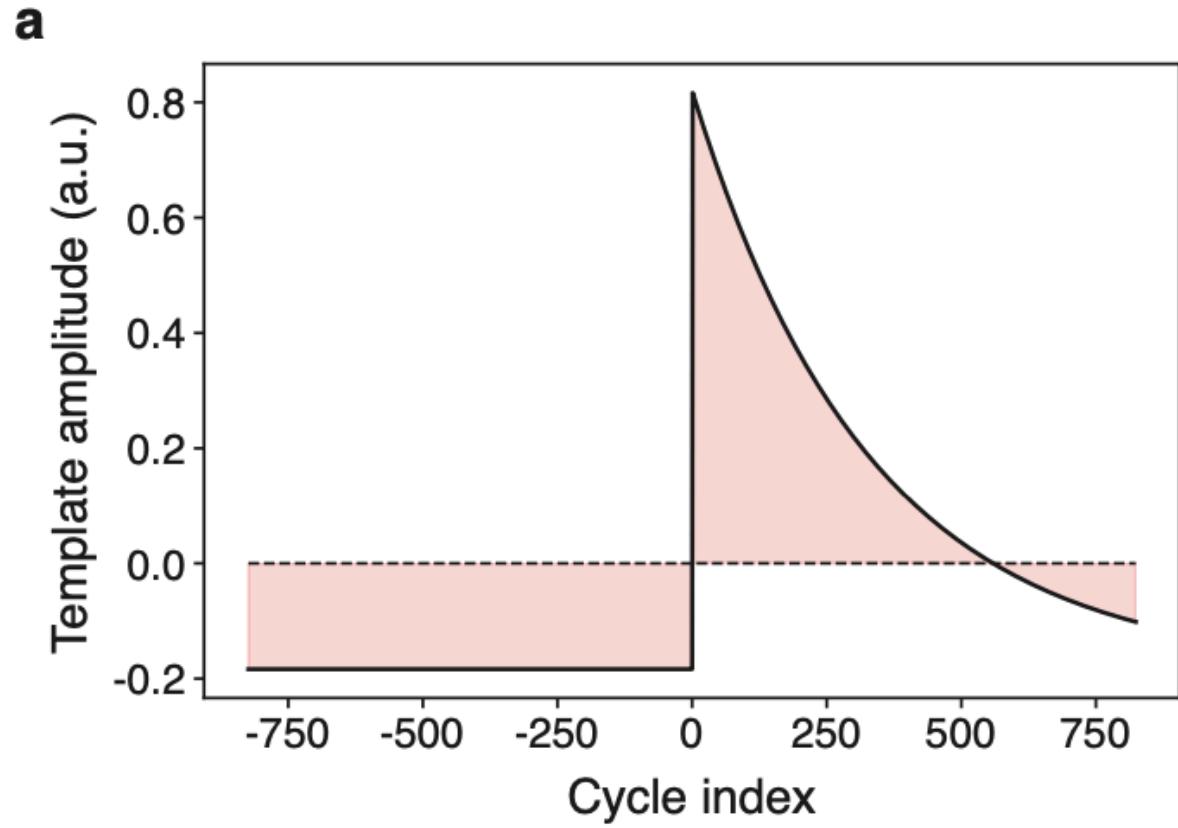
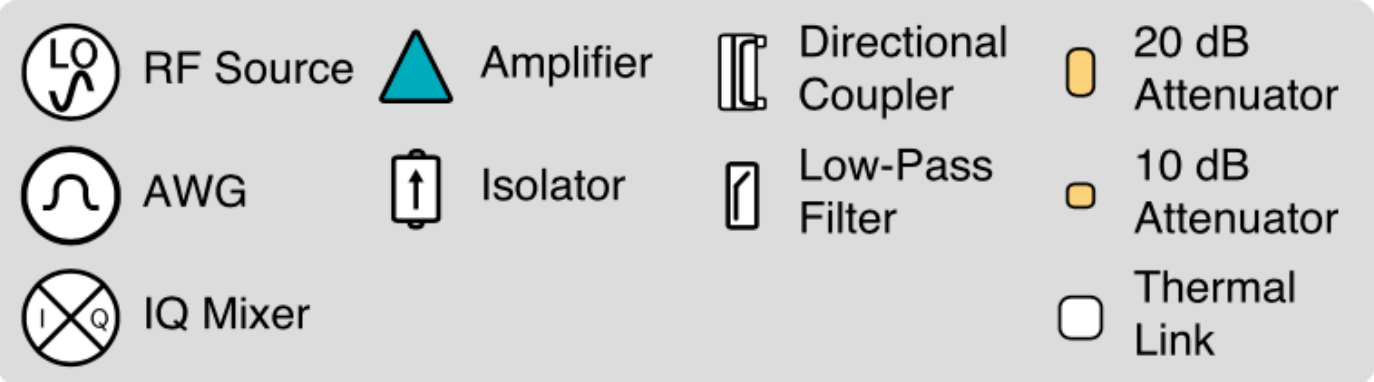

[Harrington et al, \(2024\)](#)

Model parameters

Probability of relaxation in a time Δt :

$$p_r = 1 - e^{-\Gamma(t)\Delta t}$$

$$= 1 - \exp \left[\frac{-\alpha E_{\text{dep}}}{E_{\text{dep}} \left[\tau_{ss} r \left(e^{t/\tau_{ss}} - 1 \right) \right] + \beta e^{t/\tau_{ss}}} - \gamma \right]$$

Where:

$$\alpha = \delta t \sqrt{\frac{2\omega_q \Delta}{\pi^2 \hbar}}$$

$$\beta = \frac{n_{CP} V \Delta}{\epsilon}$$

$\gamma = \text{baseline}$

Parameter	Description
Material	SC material
δt	QDR time step
r	Recombination rate
s_0	Linear loss rate
g	QP generation rate
n_{CP}	Superfluid (CP) density
Δ	SC gap energy
V	Island volume
ϵ	Phonon-to-QP efficiency
F	QP-creation Fano factor
$\omega_q/2\pi$	Qubit frequency
N	Measurement binning

Qubit name	ω_q [GHz]
Q1	4.534
Q2	4.370
Q4	4.697
Q5	4.453
Q8	4.501

Parameter	Value
n_{cp}	$4 \times 10^{24} \text{ m}^{-3}$
Δ	$180 \text{ } \mu\text{eV}$
V	$6975 \text{ } \mu\text{m}^3$
ϵ	0.6

$\delta t = \text{time step} = 1 \mu\text{s} + 1/2 \text{ R.O.} = 3 \mu\text{s}$

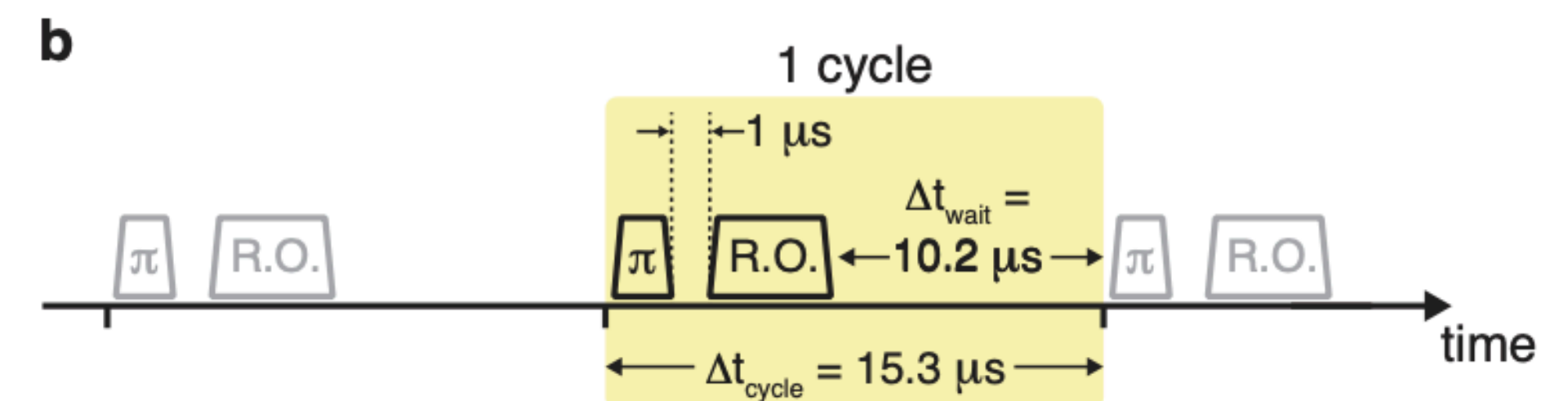

Readout fidelities

- Single shot fidelity calibration every ~ 45 min
- Calculate separation fidelity from IQ plots
- Adjust probability of relaxation accounting for readout fidelities:

$$\begin{aligned}
 p_{\text{obs}} &= p_r \cdot p_g + (1 - p_r) \cdot p_{ge} \\
 &= p_r \cdot \mathcal{F} + p_{ge}
 \end{aligned}$$

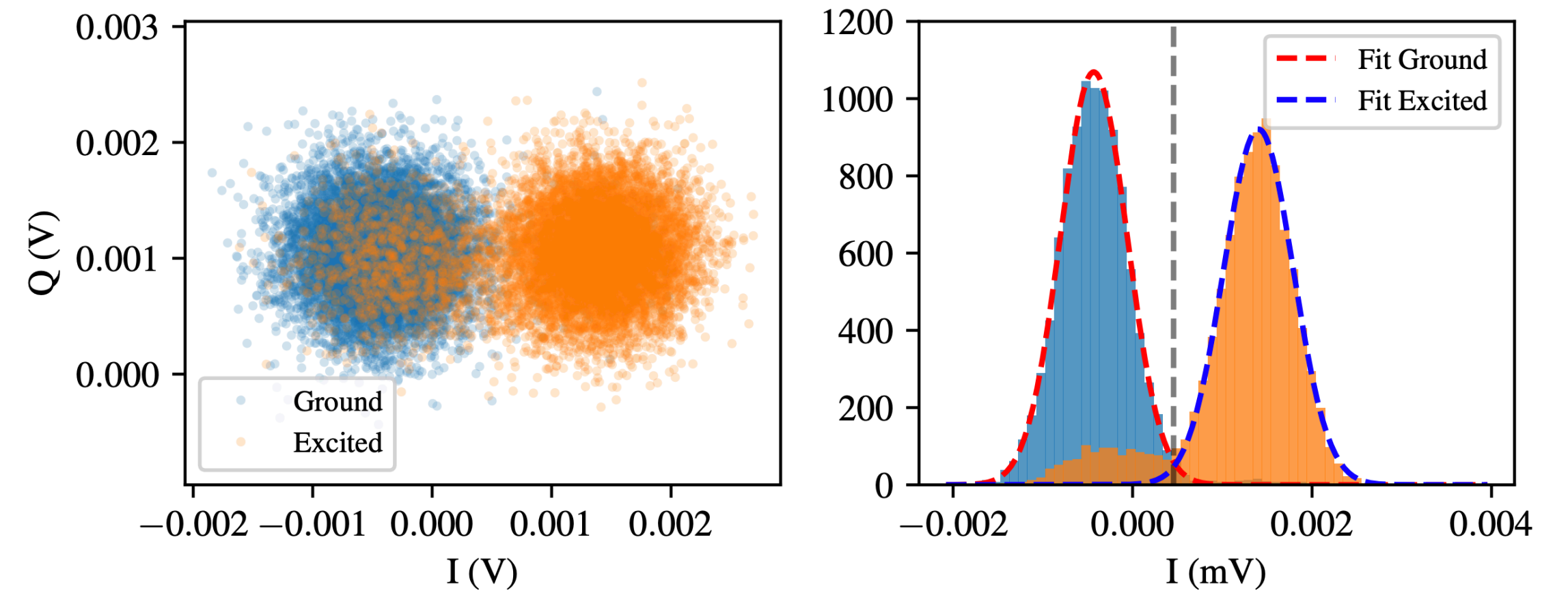

Qubit name	$\frac{\omega_q}{2\pi}$ [GHz]	Run-07		Run-13	
		\mathcal{F} [%]	p_{ge} [%]	\mathcal{F} [%]	p_{ge} [%]
Q1	4.534	99.96	0.02	99.75	0.13
Q2	4.370	99.65	0.20	98.51	0.79
Q4	4.697	99.70	0.13	99.25	0.35
Q5	4.453	99.92	0.04	99.58	0.22
Q8	4.501	99.16	0.47	98.04	1.02

Fit procedure



For each waveform sample, the probability of finding s errors is given by a binomial

$$\text{distribution: } p(s) = \binom{N}{s} p_{\text{obs}}^s (1 - p_{\text{obs}})^{(N-s)}$$

The joint probability of acquiring a set of measured waveform samples $\{s_i\}$ at times $\{t_i\}$:

$$\mathcal{L} \left(\{s_i\} \mid S(t) \right) = \prod_i \binom{N}{s_i} p_{\text{obs}}^{s_i}(t_i) \left(1 - p_{\text{obs}}(t_i) \right)^{(N-s_i)}$$

- **Binomial Maximum Likelihood** fit for each acquired waveform
- Bayesian approach \rightarrow integrate the joint posterior pdf:

$$p \left(S(t; \hat{\theta}) \mid \{s_i\} \right) = \mathcal{L} \left(\{s_i\} \mid S(t; \hat{\theta}) \right) \pi(\hat{\theta})$$

- **BAT**: software using Markov Chain Monte Carlo algorithms to integrate the posterior pdf

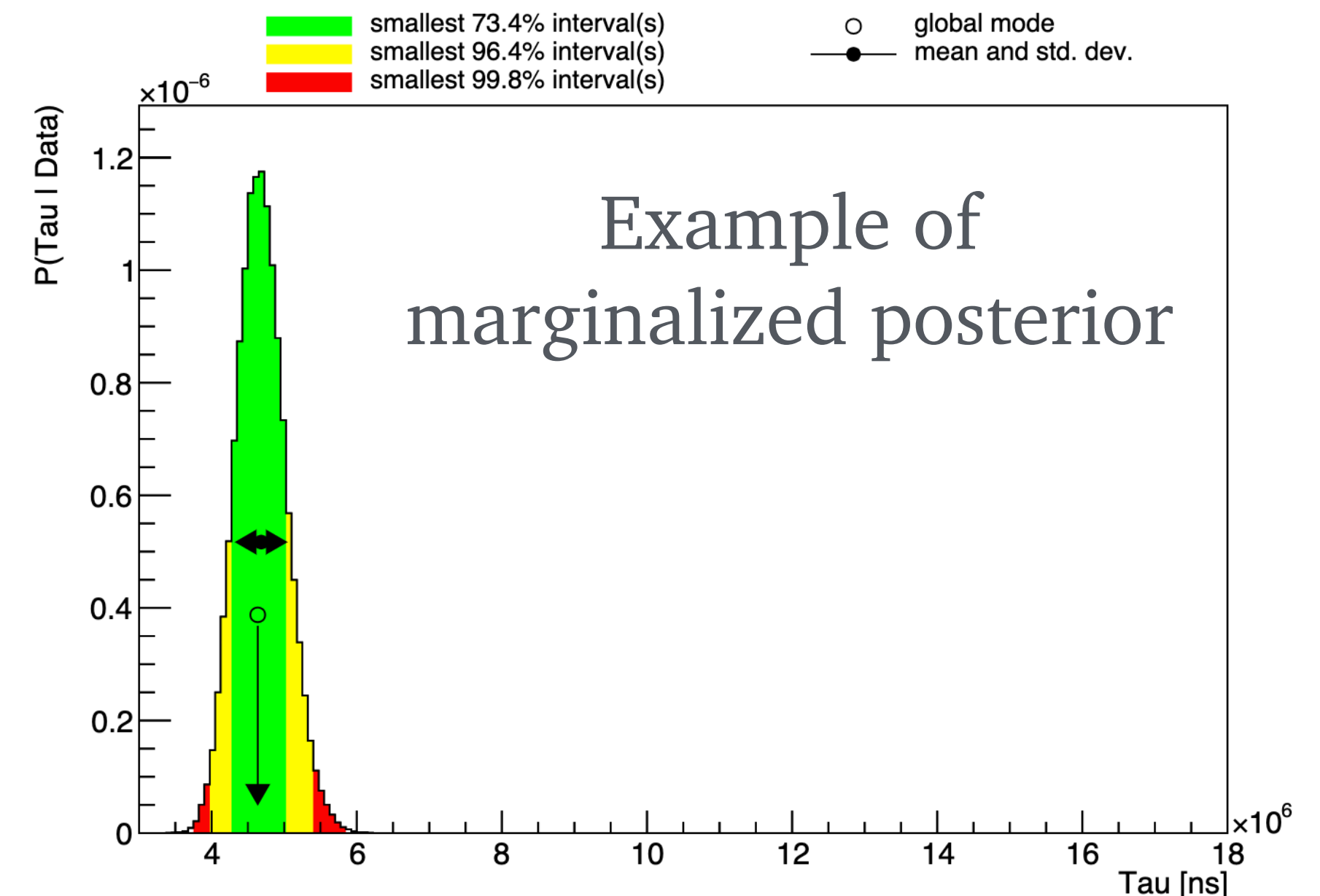

Position reconstruction

1. Take as input the energy extracted with the energy fit and its uncertainty
2. Get the phonon dispersion function from G4CMP simulation
3. Apply position reconstruction algorithm:

$$\chi^2(x, y, E_{tot}) = \sum_{i=1}^N \left(\frac{S_i^{\text{obs}} - S_i^{\text{model}}(x, y, E_{tot})}{\sigma_i} \right)^2$$

Point-like energy deposition on XY

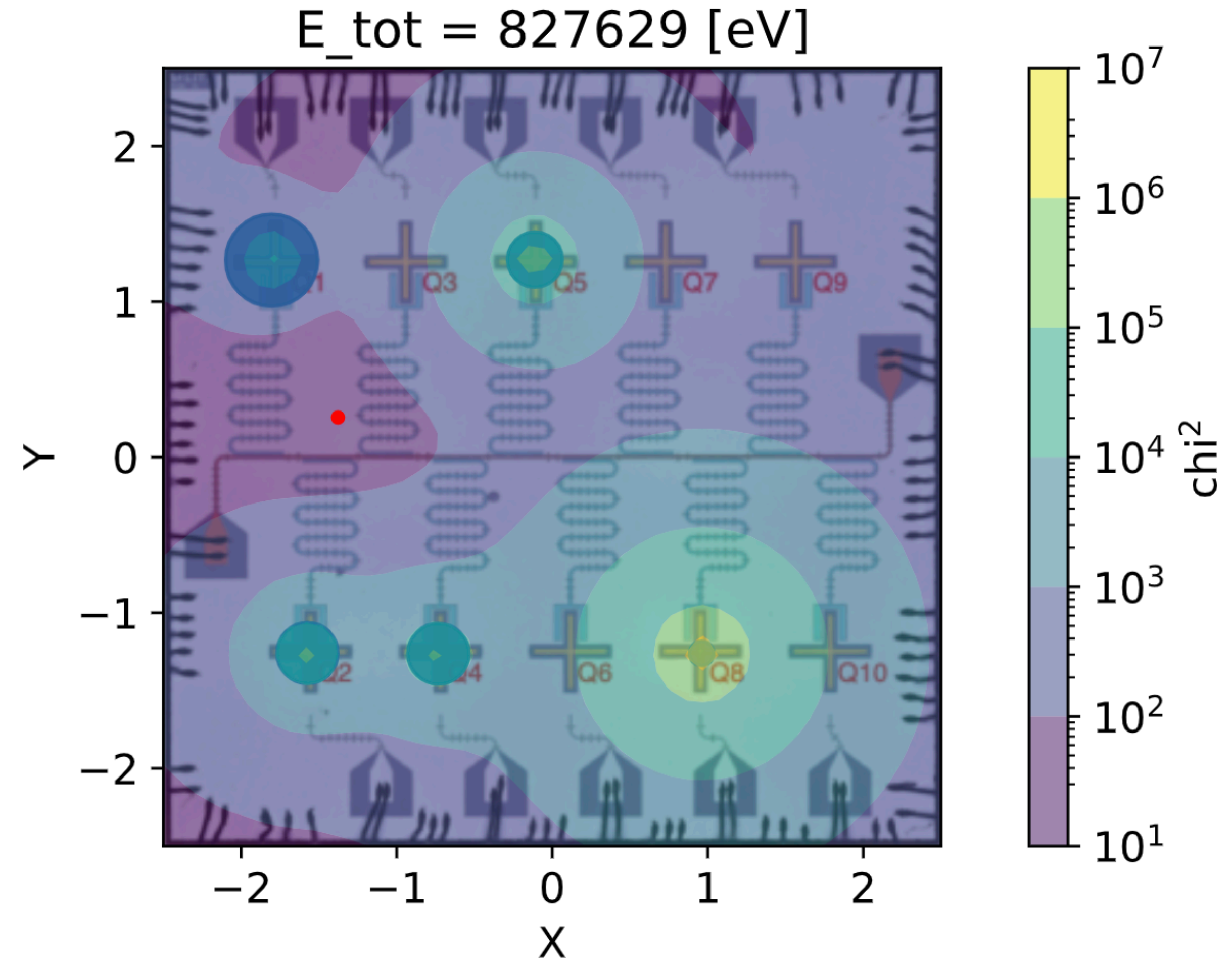

Quasiparticle density model

Knowing the superfluid (CP) density n_{CP} for a given material, it is then possible to model the normalized quasiparticle density $x_{qp} = n_{qp}/n_{CP}$ with:

$$\frac{dx_{qp}}{dt} = -rx_{qp}^2 - s_0x_{qp} + g$$

r = recombination constant (expected to be as large as its theoretically motivated value 0.05)

s_0 = linear loss due to QP trapping

g = QP generation

$$\begin{aligned} x_{qp} &= x_i \frac{1 - r'}{e^{t/\tau_{ss}} - r'} + x_0 \\ &= \left[\frac{E_{\text{dep}}\epsilon}{n_{CP}V\Delta} \right] \frac{1 - r'}{e^{t/\tau_{ss}} - r'} + x_0. \end{aligned} \quad (8)$$

$$\Gamma(t) = \sqrt{\frac{2\omega_q\Delta}{\pi^2\hbar}} \left(\left[\frac{E_{\text{dep}}\epsilon}{n_{CP}V\Delta} \right] \frac{1 - r'}{e^{t/\tau_{ss}} - r'} + x_0 \right) + \Gamma_{\text{other}}.$$

$$r' = \tau_{ss}x_i r / [\tau_{ss}x_i r + 1]$$

Here, τ_{ss} , r' , and x_0 are functions of r , s_0 , g , and x_i .³
 Notably, τ_{ss} is the “steady-state” decay time for the QP relaxation, found when x_{qp} becomes small enough that self-recombination becomes subdominant.

Superconducting detectors in DM searches

Something we know very well

→ Transition Edge Sensors (TES)

→ Kinetic Inductance Detectors (KID)
CP breaking detection

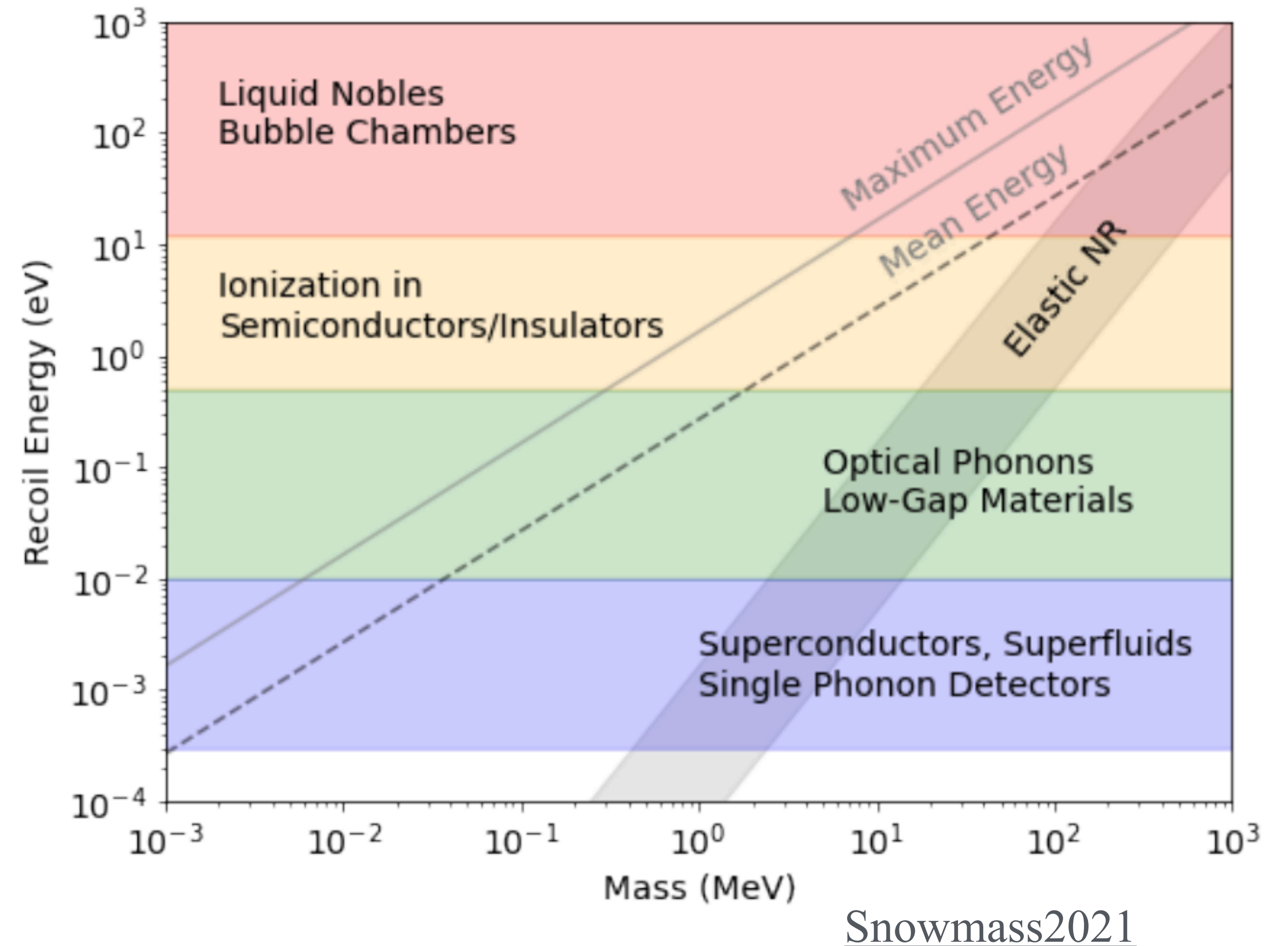
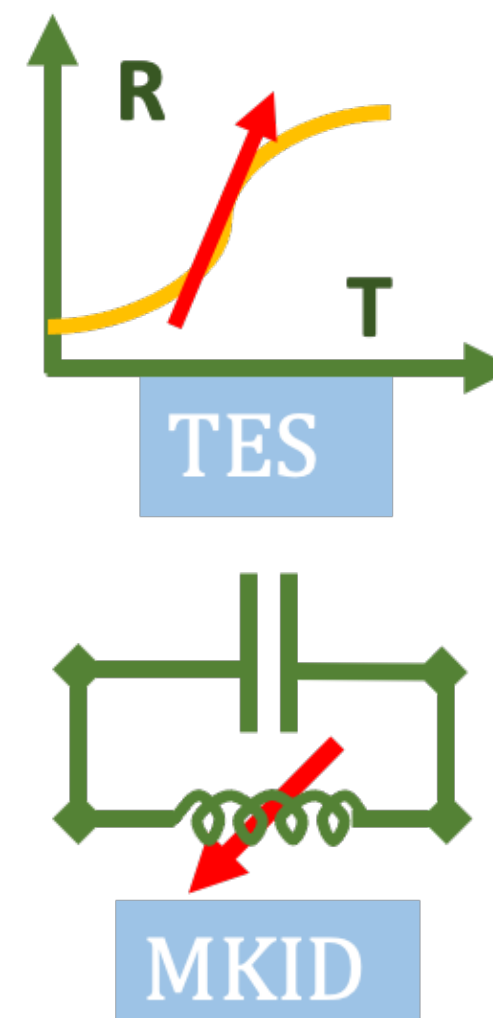
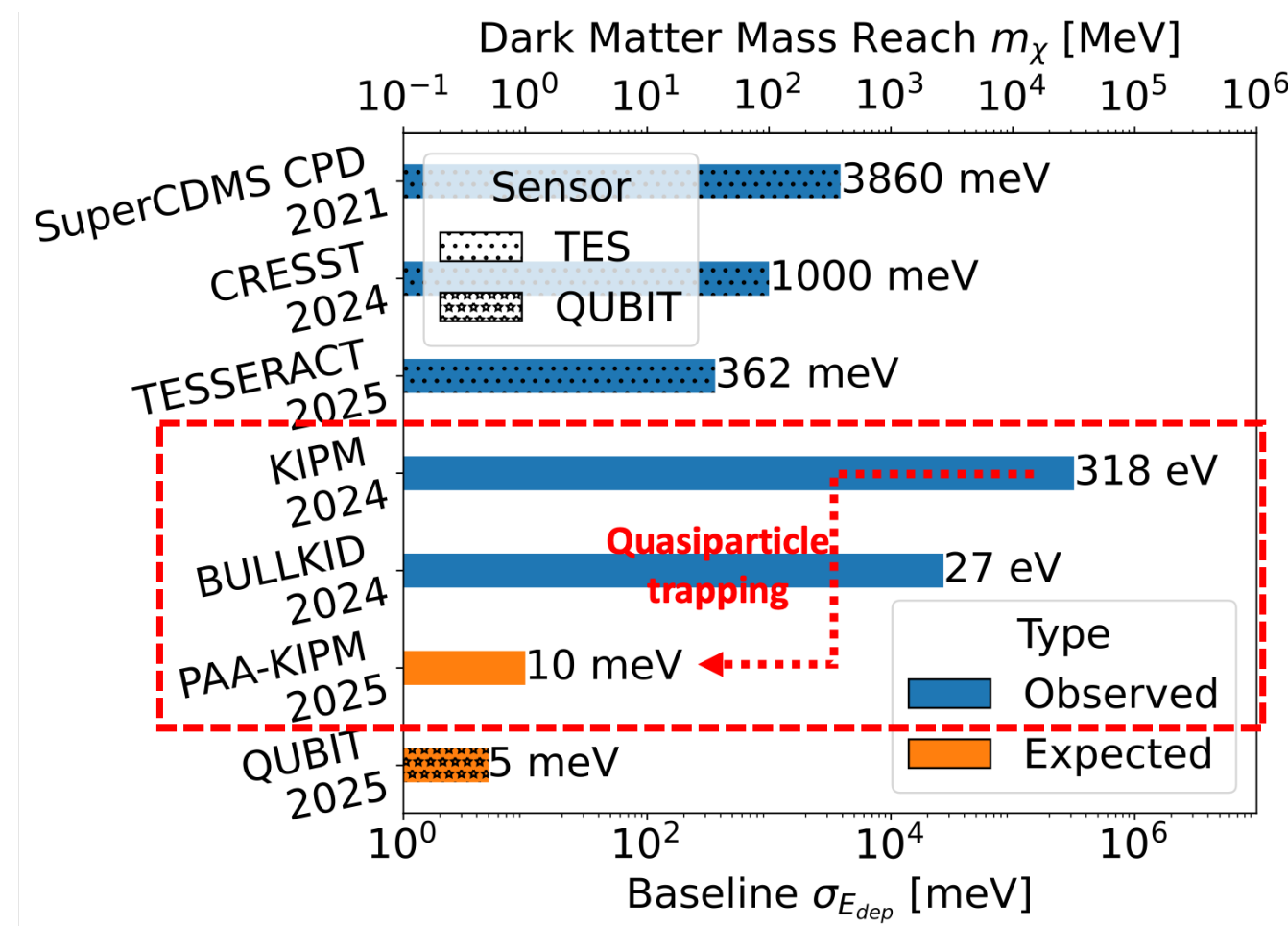

Solid state simulations

- G4CMP is a Geant4 library that allows simulating phonon dynamic on specific geometries
Two main processes:
 - anharmonic down-conversion, $\Gamma_{\text{anh}} = A\nu^5$
 - isotopic scattering, $\Gamma_{\text{scatter}} = A\nu^4$
- Several materials now implemented
- Main uncertainty:
 - **probability of phonon absorption at the interface** with superconducting film ($p_{a,s}$) and copper frames ($p_{a,c}$)

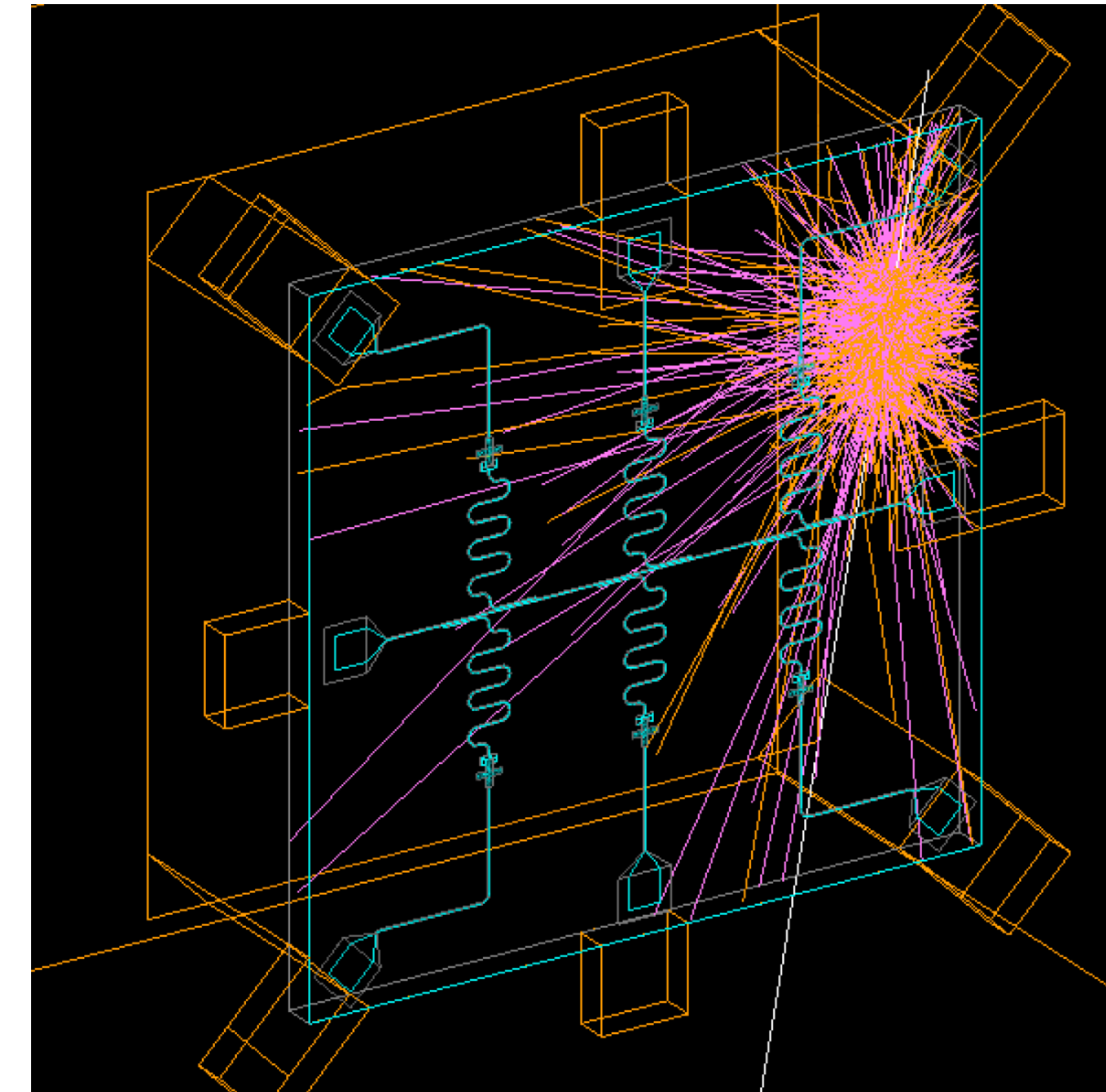

Example GaAs

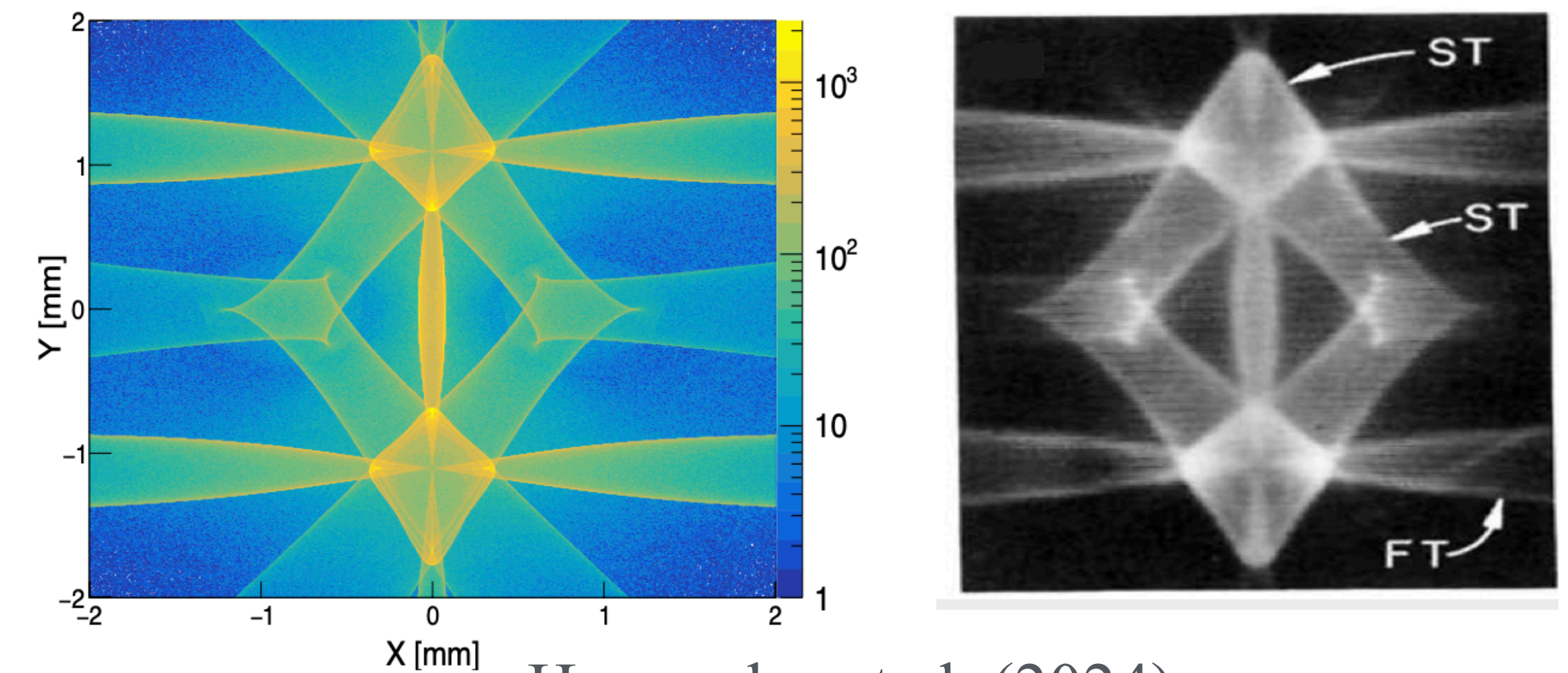

Hernandez at al. (2024)

Base variables

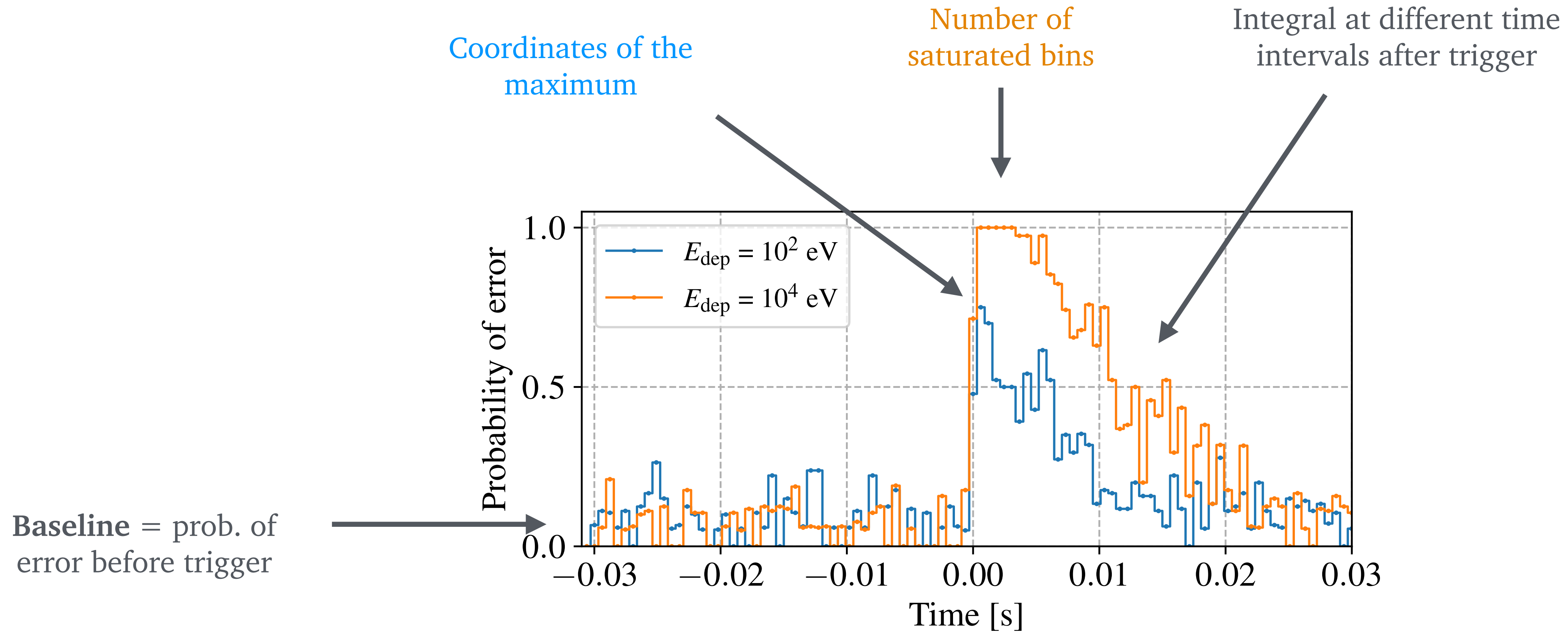

Events selection

- Baseline instabilities over time
→ typical Two Level Systems (TLS) behavior
- Quality cuts applied

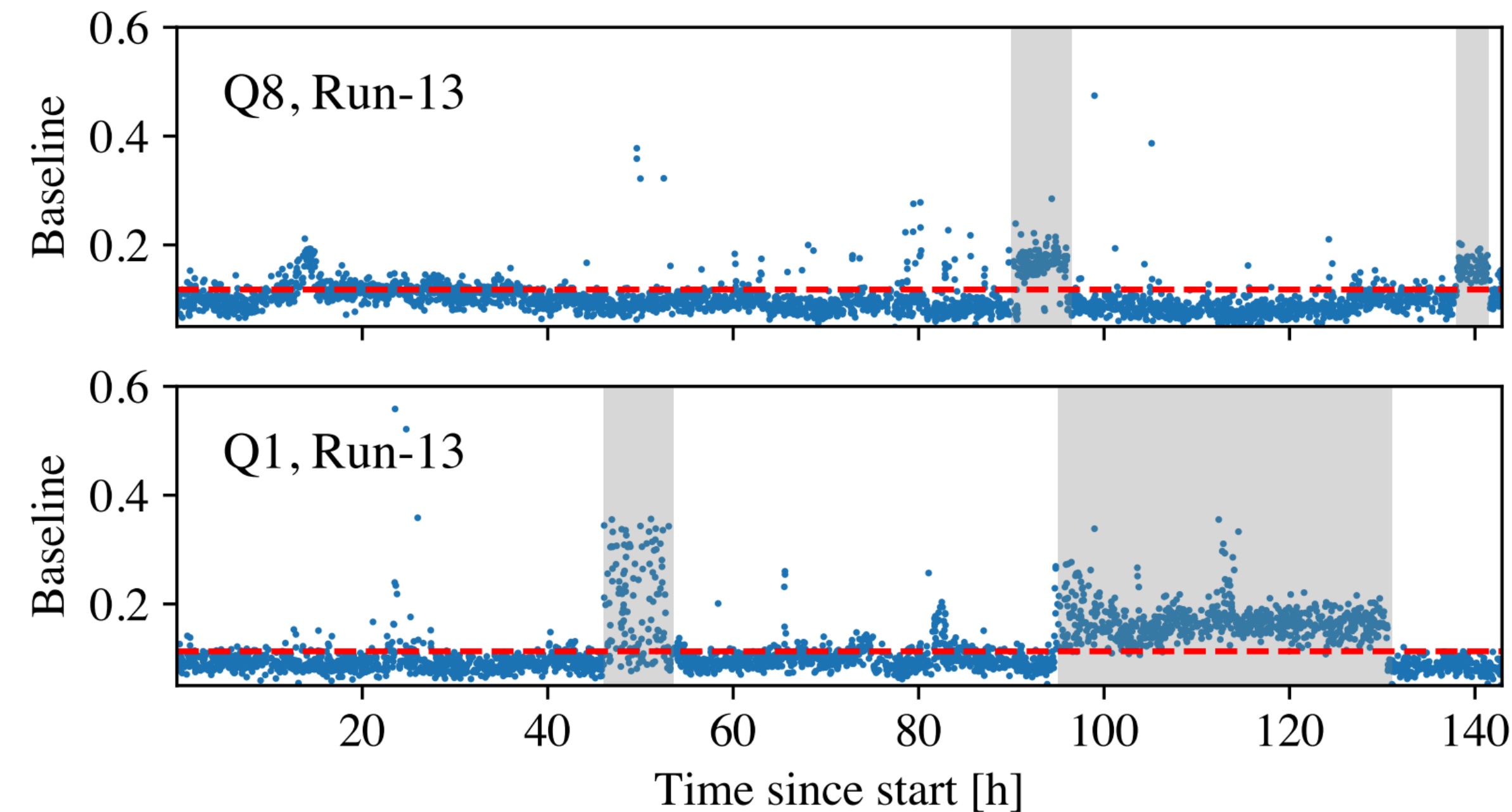

Qubit	¹³⁷ Cs run			Bkg run		
	ϵ_Q [%]	ϵ_A [%]	ϵ_{tot} [%]	ϵ_Q [%]	ϵ_A [%]	ϵ_{tot} [%]
Q1	76.5	85.5	65.3	63.5	84.9	54.2
Q2	92.4	86.0	79.4	93.3	86.4	81.0
Q4	92.8	84.1	78.2	93.0	84.3	78.1
Q5	74.6	86.0	64.8	91.6	85.0	77.8
Q8	79.7	85.7	68.3	85.9	86.0	73.8
all	36.2	43.9	16.2	41.7	44.6	18.6

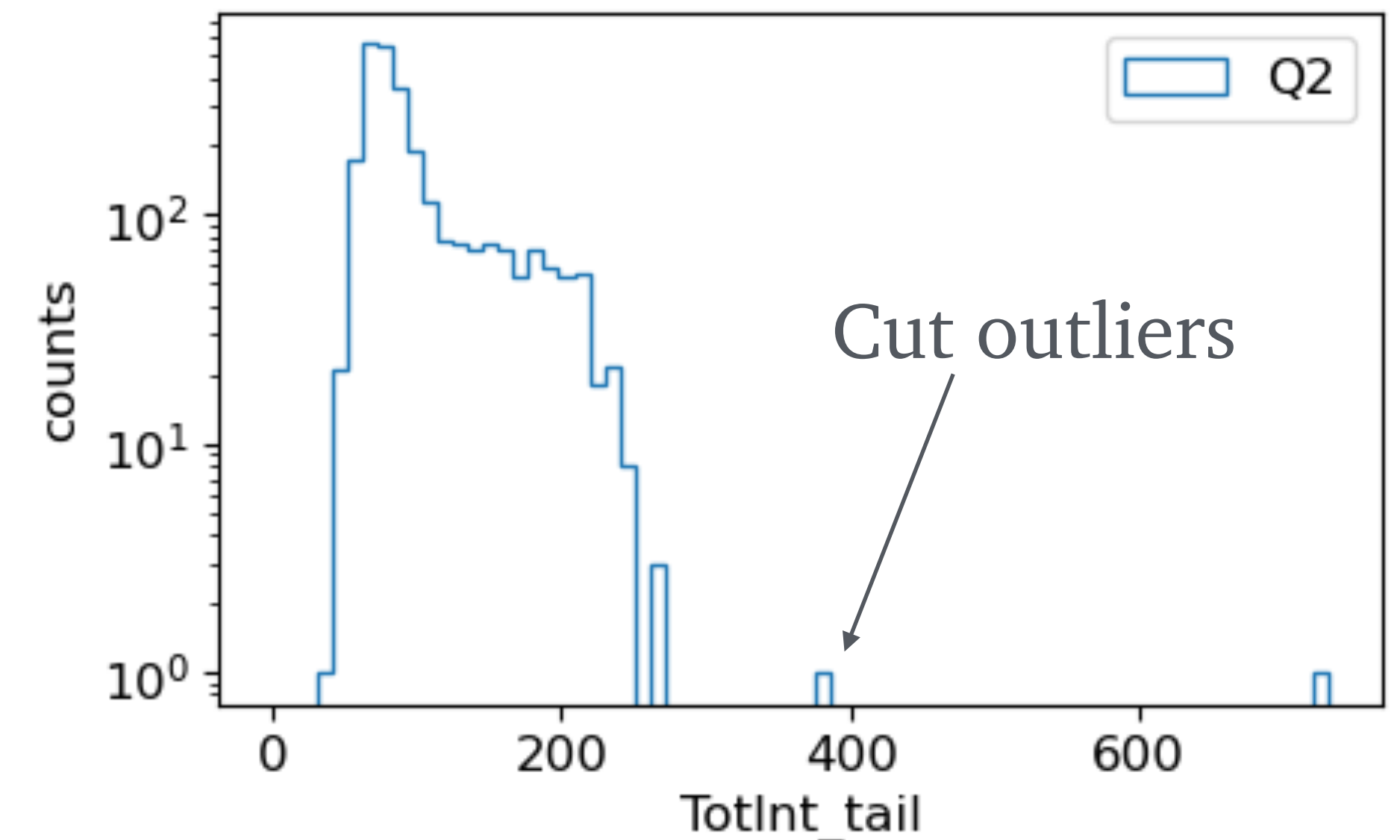

Average pulse

$$p_r = 1 - e^{-\Gamma(t)\Delta t}$$

$$= 1 - \exp \left[\frac{-\alpha E_{\text{dep}}}{E_{\text{dep}}(\tau_{ss}r)(e^{t/\tau_{ss}} - 1) + \beta e^{t/\tau_{ss}} - \gamma} \right]$$

Saturated events selection → number of saturated bins

Low energy selection → Baseline RMS

Red: Average pulse

Grey: pulses averaged

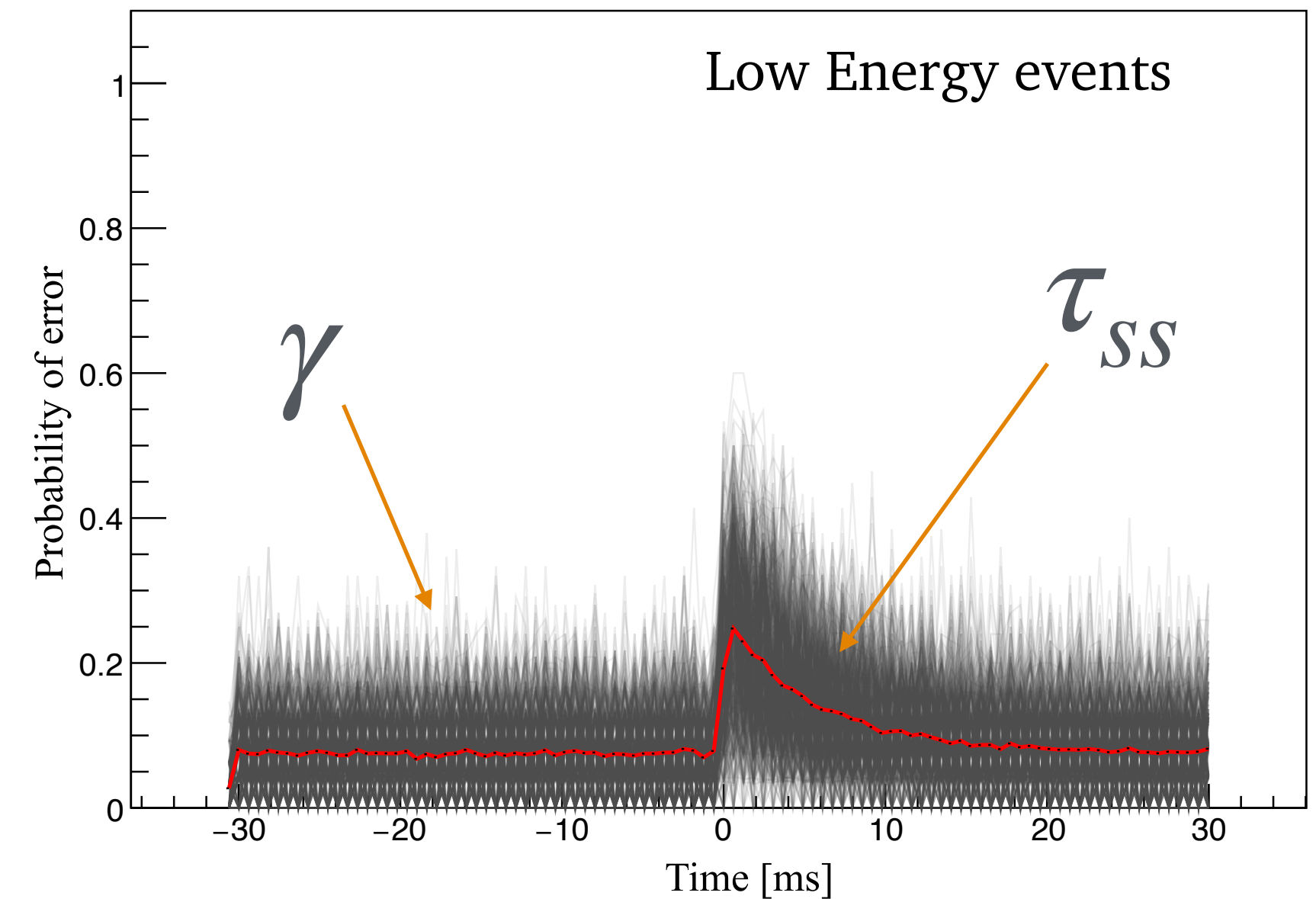
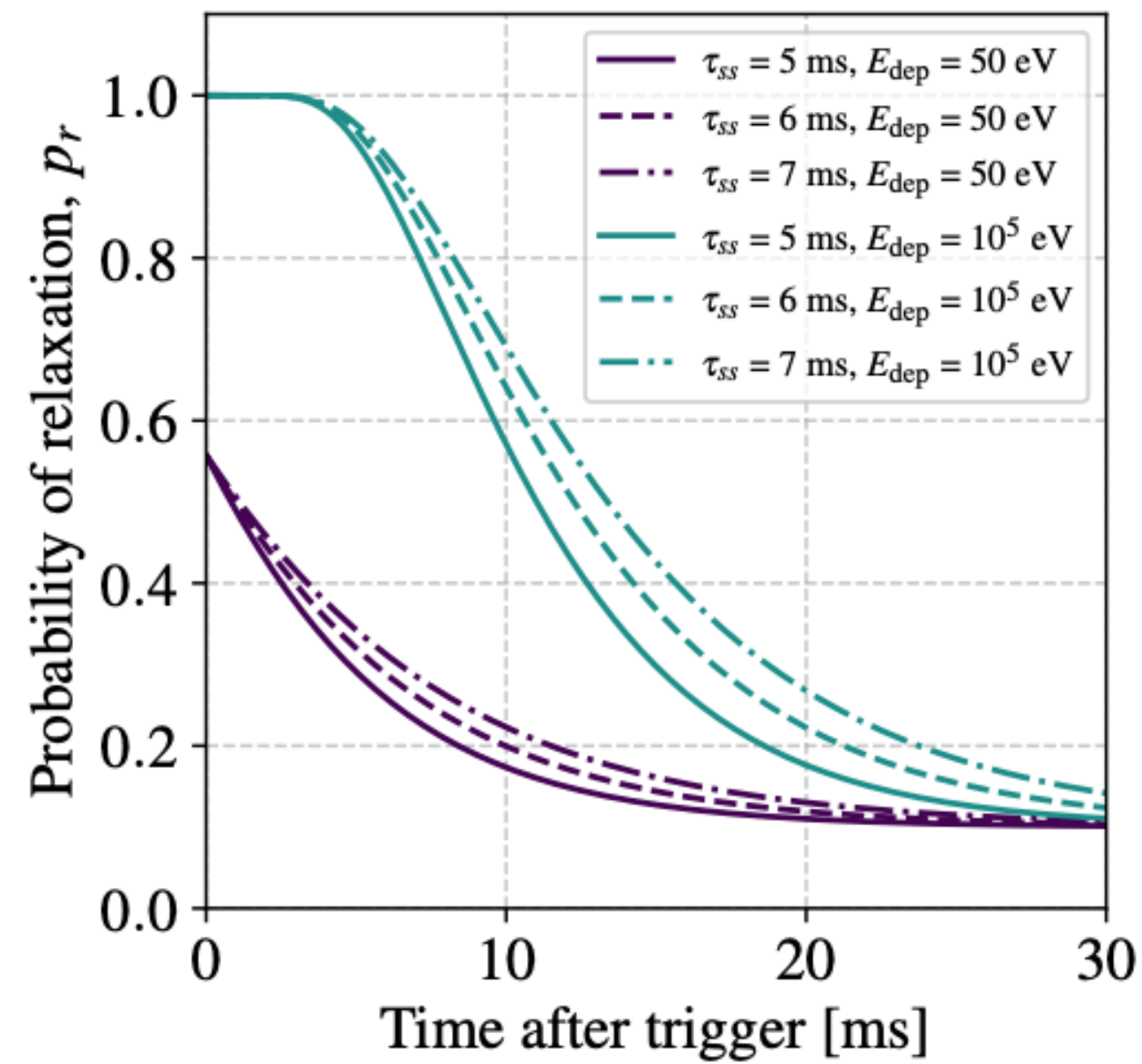
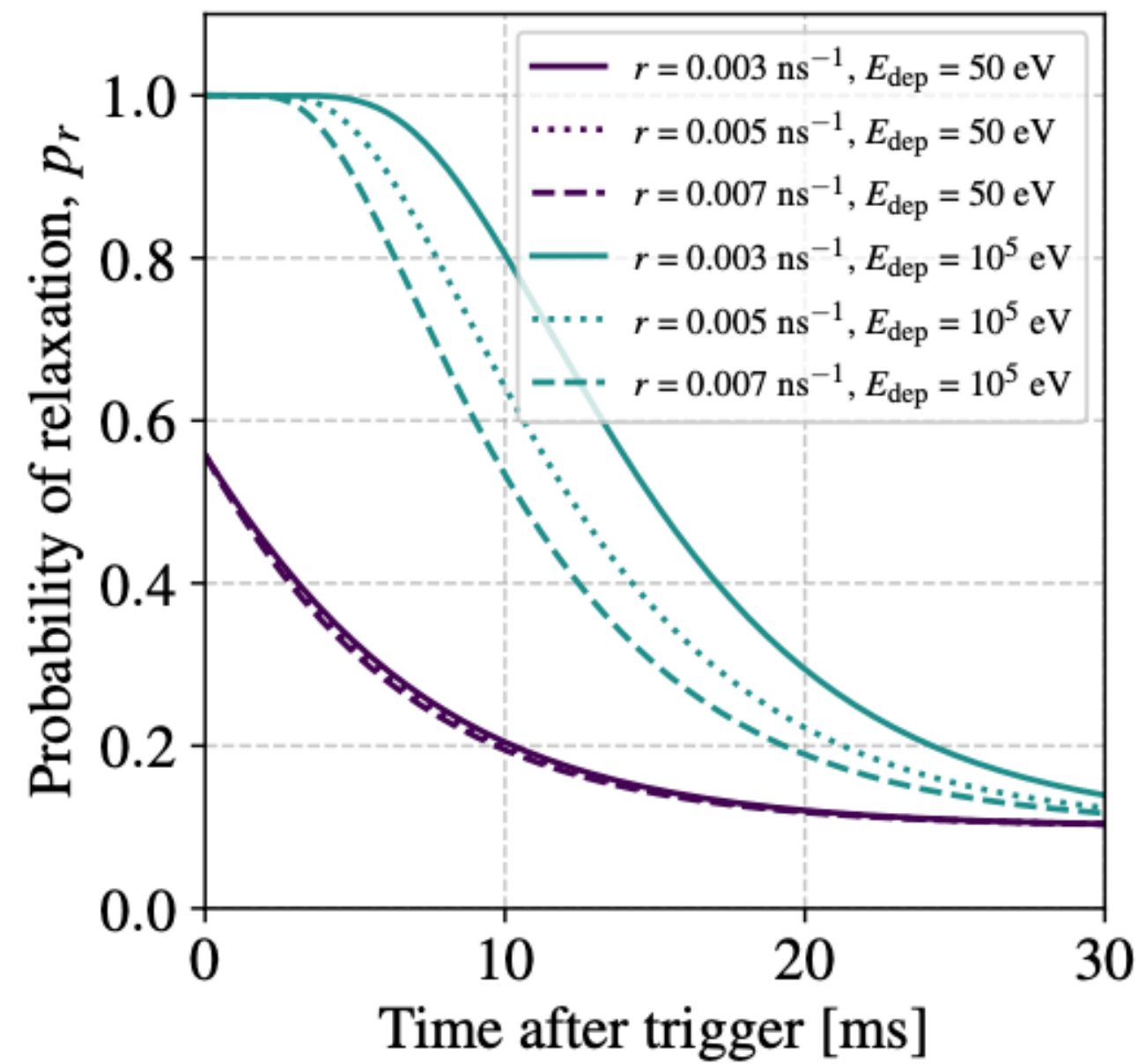
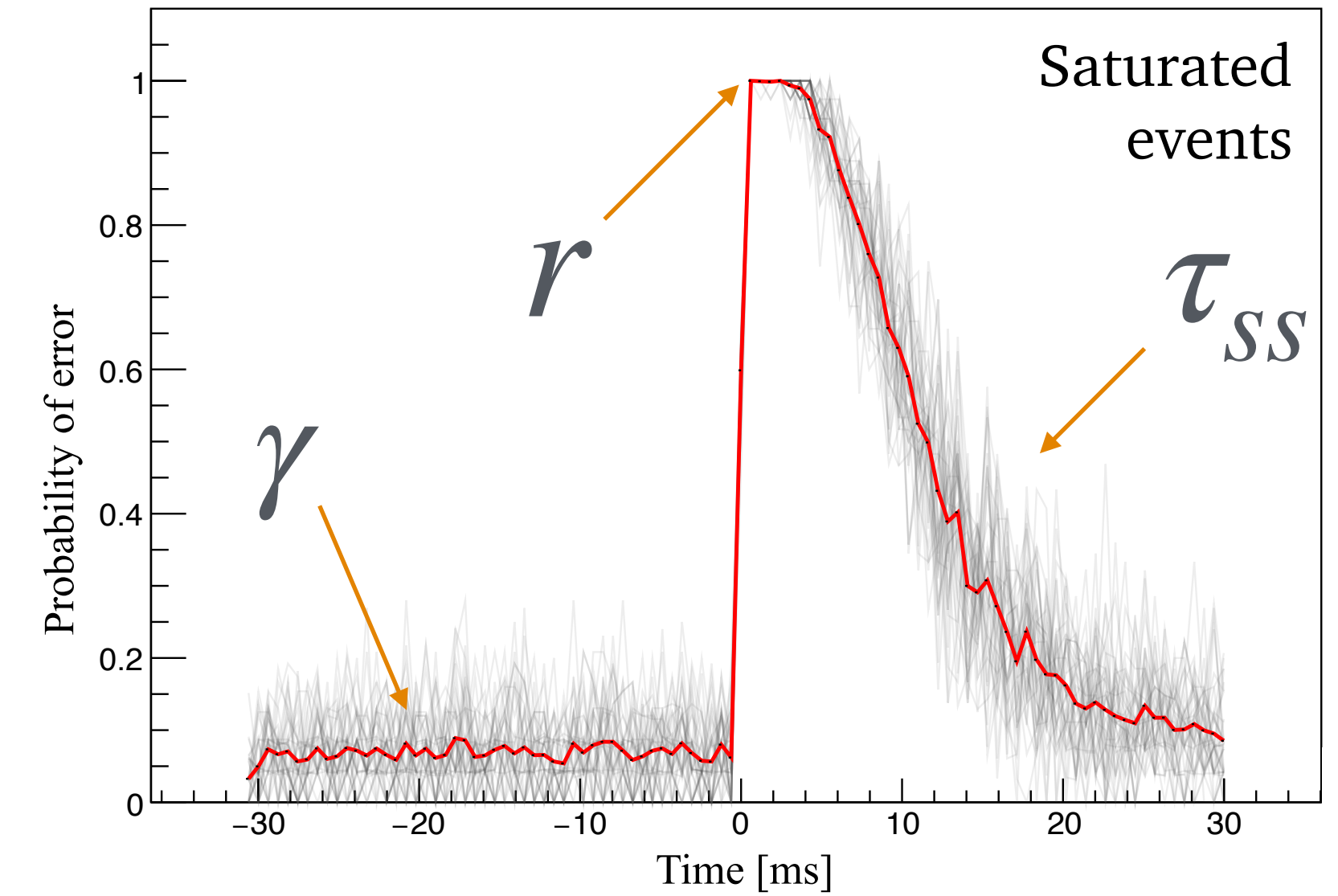

Recombination constant results

- ❖ Good agreement among different datasets
 - ❖ Previous measurements of r in the range $0.0059\text{--}0.125\text{ ns}^{-1}$
 - ❖ In line with previous results, we measured a factor 10 suppression respect to the theoretical expected value $r = 0.05\text{ ns}^{-1}$ in aluminum
 - ❖ The analysis on saturated and low energy pulses shows an unexpected dependence of τ_{ss} on the energy deposited
- other measurements artificially produced QP via phonon injectors or 3D cavities, we used only radioactivity!

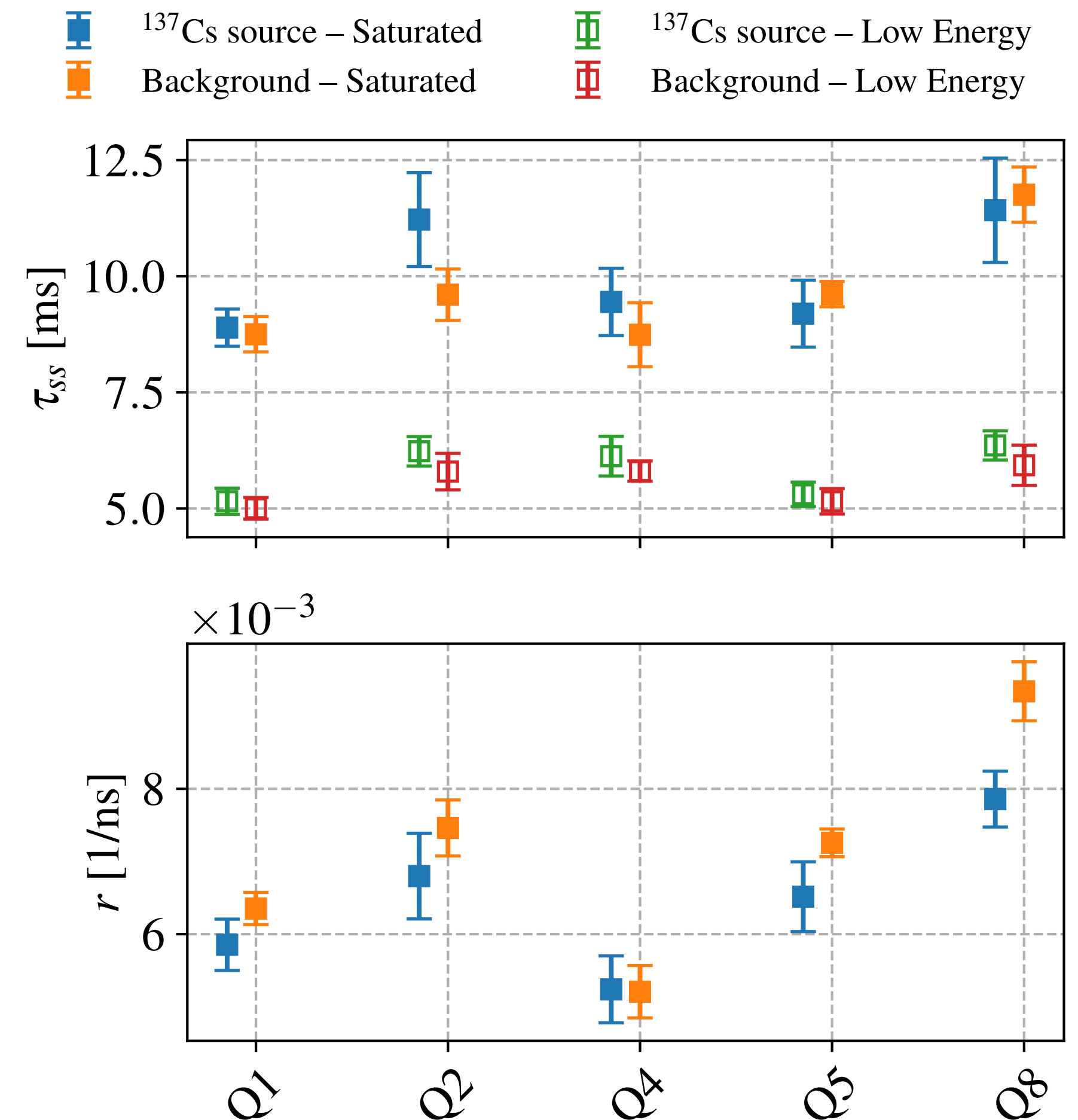

Fit test with mock data

- Replicate pulse sequence following measurement scheme and QP density model with a set of input parameters
- Bias spotted on energy reconstruction for $E_{dep} > 500$ eV

