

Correlated Error Bursts and QEC

Gabrielle Roberts

Vlad Kurilovich, Alex Opremcak, Matt McEwen, Kevin Miao,
John Mark Kreikebaum, Kevin Satzinger, and many others

Quantum error correction: a bridge to practical applications

Hardware goal

Build qubits with
gate error $\sim 10^{-10}$

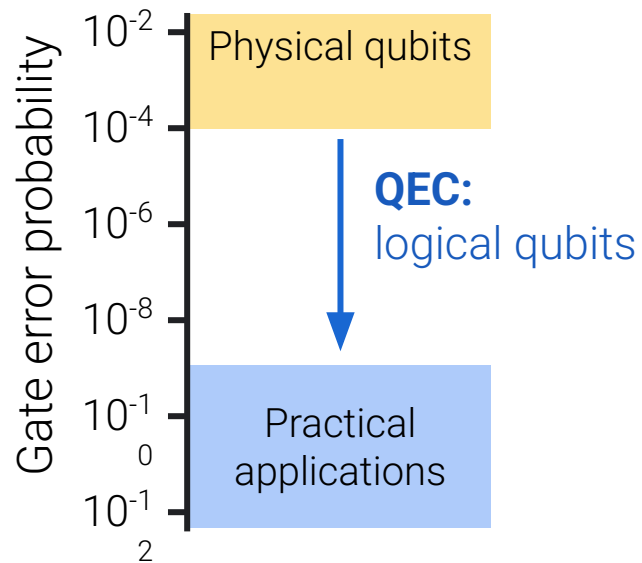

Quantum error correction: a bridge to practical applications

Hardware goal

Build qubits with gate error $\sim 10^{-10}$

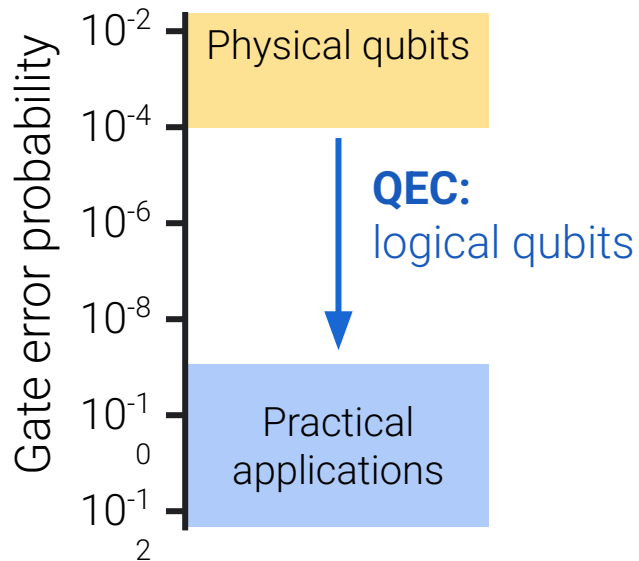

Surface code logical qubit

Distribute quantum state over d^2 physical qubits

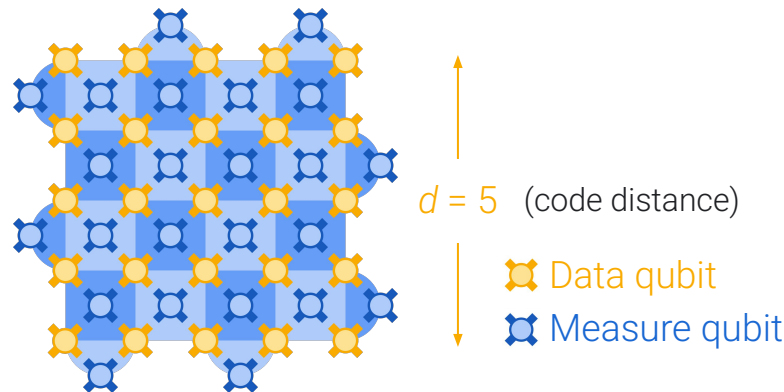

With sufficient **performance**,
increase d to **exponentially suppress** errors
(in theory)

Exponential Suppression of Errors

Trade many good physical qubits for one excellent logical qubit

Threshold:

Suppress errors with scale
when hardware is *good enough*

Empirical formula:

$$\text{Logical error per cycle } \epsilon_d = C \cdot \left(\frac{\text{Physical error rate}}{\text{Threshold error rate}} \right)^{(distance+1)/2}$$

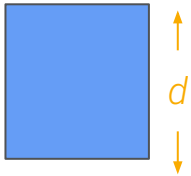

Exponential Suppression of Errors

Trade many good physical qubits for one excellent logical qubit

Threshold:

Suppress errors with scale
when hardware is *good enough*

Empirical formula:

$$\text{Logical error per cycle } \epsilon_d = C \cdot \left(\frac{p}{p_{th}} \right)^{(d+1)/2}$$

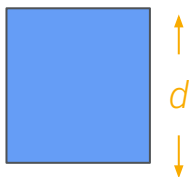

\uparrow
 $1/\Lambda$

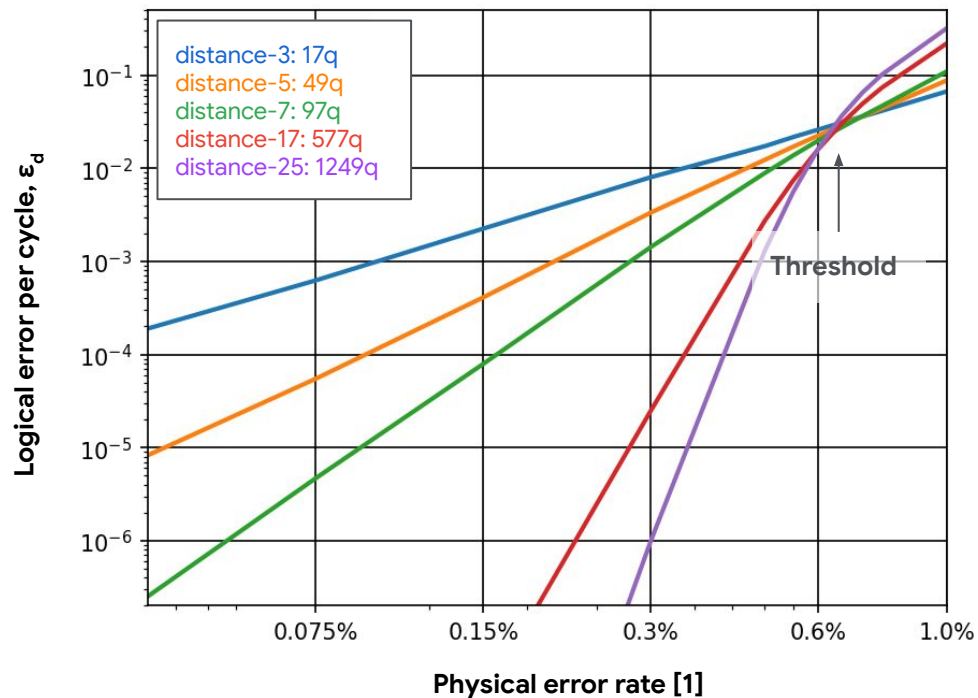

Exponential Suppression of Errors

Trade many good physical qubits for one excellent logical qubit

Threshold:

Suppress errors with scale
when hardware is *good enough*

Empirical formula:

$$\text{Logical error per cycle } \epsilon_d = C \cdot \left(\frac{p}{p_{th}} \right)^{(d+1)/2}$$

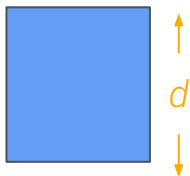

\uparrow
 $1/\Lambda$

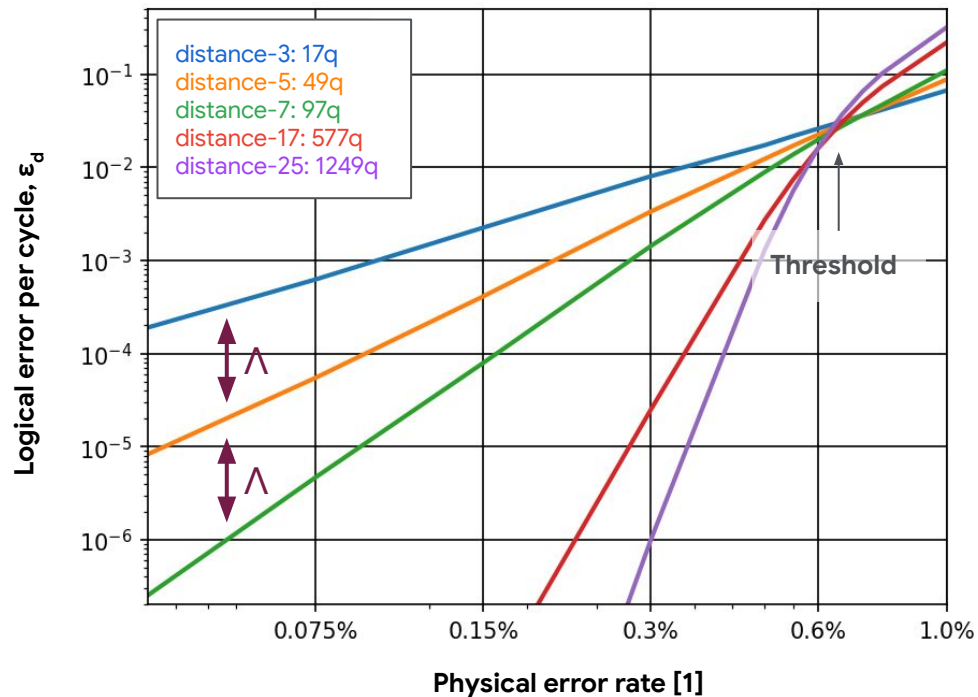

Exponential Suppression of Errors

Trade many good physical qubits for one excellent logical qubit

Threshold:

Suppress errors with scale
when hardware is *good enough*

Empirical formula:

$$\text{Logical error per cycle } \epsilon_d = C \cdot \left(\frac{p}{p_{th}} \right)^{(d+1)/2}$$

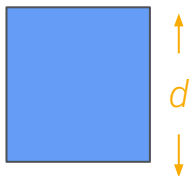

\uparrow
 $1/\Lambda$

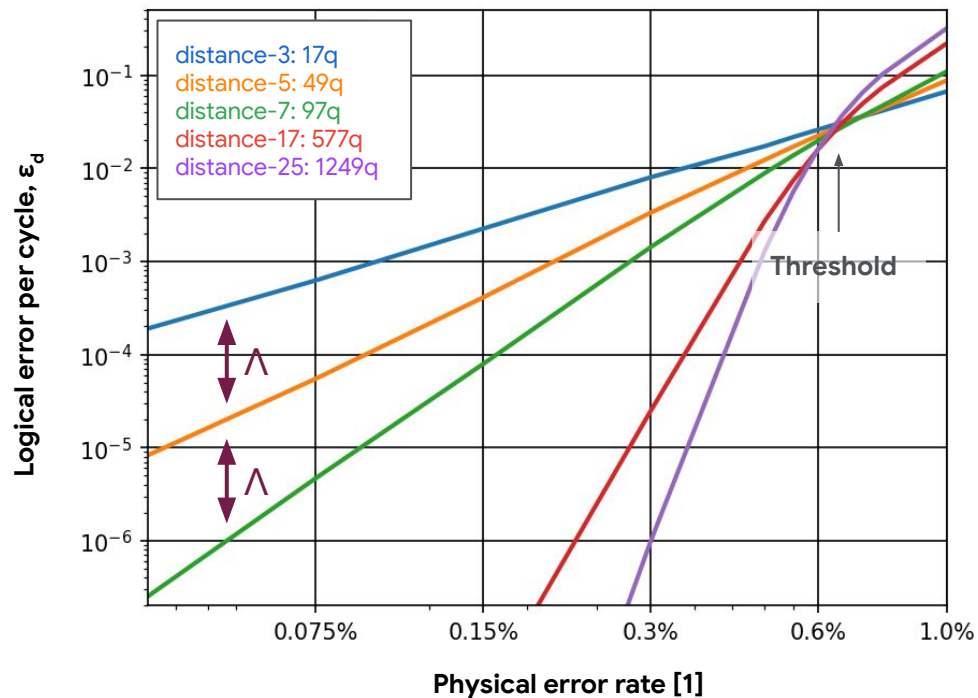

**QEC: a path to extremely low error rates,
if hardware is good enough and errors are local**

Repetition Code

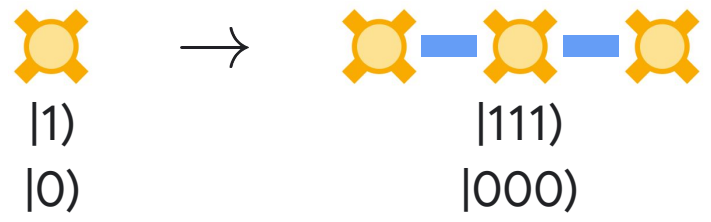

Repetition Code



Repetition Code



If only **one** error occurred, majority vote is guaranteed to succeed

Repetition Code

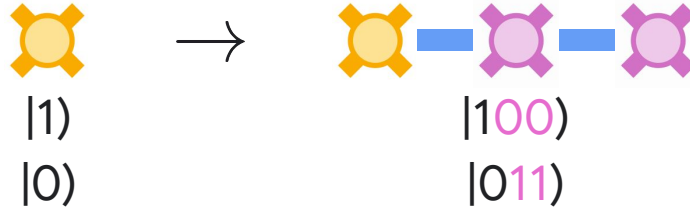

If only **one** error occurred, majority vote is guaranteed to succeed
Does **not** protect from two errors

Repetition Code



If only **one** error occurred, majority vote is guaranteed to succeed
Does **not** protect from two errors



Repetition Code

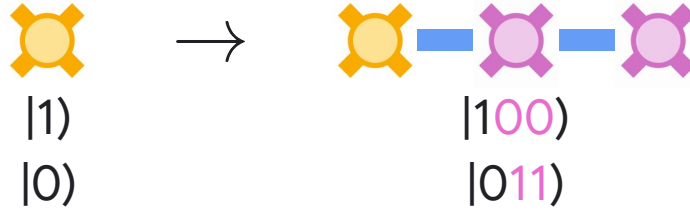

If only **one** error occurred, majority vote is guaranteed to succeed
Does **not** protect from two errors



Repetition Code



If  \rightarrow  with probability p ,

then a logical error occurs with a probability $p_L \propto p^{(d+1)/2}$

Quantum Repetition Code

$$|\psi\rangle_L = \alpha|000000\rangle + \beta|111111\rangle$$



Quantum Repetition Code

$$|\psi\rangle_L = \alpha|000000\rangle + \beta|111111\rangle$$

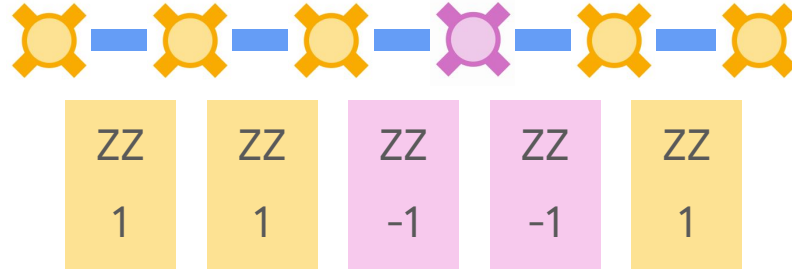

Detail: instead of measuring data qubits directly (collapses the state), we instead do pair-wise parity measurements to locally detect an error.

Syndrome Extraction



$|0\rangle$



Syndrome Extraction

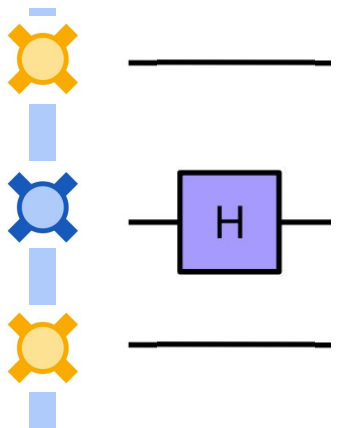

$|0\rangle$

$|0\rangle+|1\rangle$

Syndrome Extraction

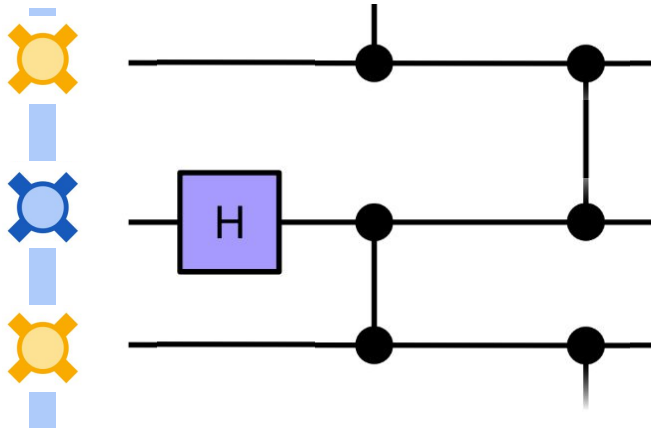

$|0\rangle$

$|0\rangle+|1\rangle$

$|0\rangle+|1\rangle*(Z_1)(Z_2)$

Even parity: $|0\rangle+|1\rangle \rightarrow |+\rangle$

Odd parity: $|0\rangle-|1\rangle \rightarrow |-\rangle$



Syndrome Extraction

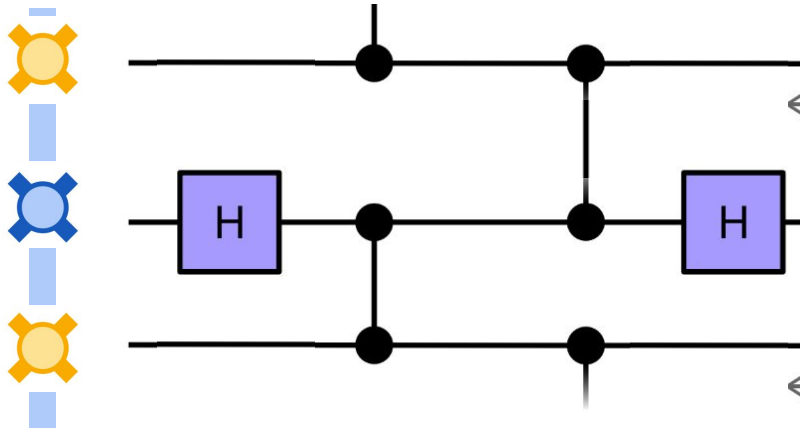

$|0\rangle$

$|0\rangle+|1\rangle$

$|0\rangle+|1\rangle*(Z_1)(Z_2)$

Even parity: $|0\rangle+|1\rangle \rightarrow |+\rangle$

$|0\rangle$

Odd parity: $|0\rangle-|1\rangle \rightarrow |-\rangle$

$|1\rangle$



Syndrome Extraction

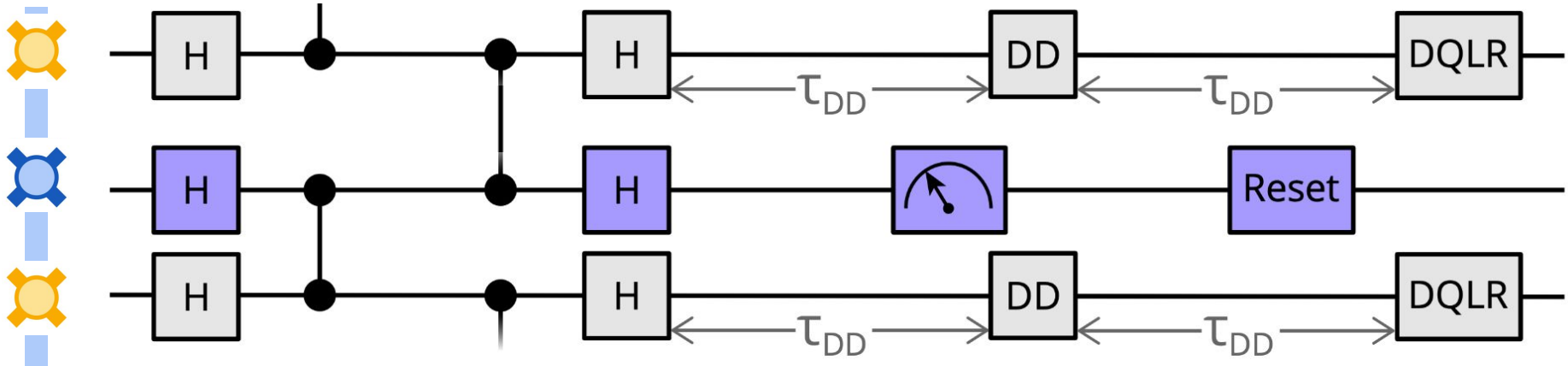

$|0\rangle$

$|0\rangle+|1\rangle$

$|0\rangle+|1\rangle*(Z_1)(Z_2)$

Even parity: $|0\rangle+|1\rangle \rightarrow |+\rangle$ $|0\rangle$

Odd parity: $|0\rangle-|1\rangle \rightarrow |-\rangle$ $|1\rangle$



Surface Code Logical Qubit

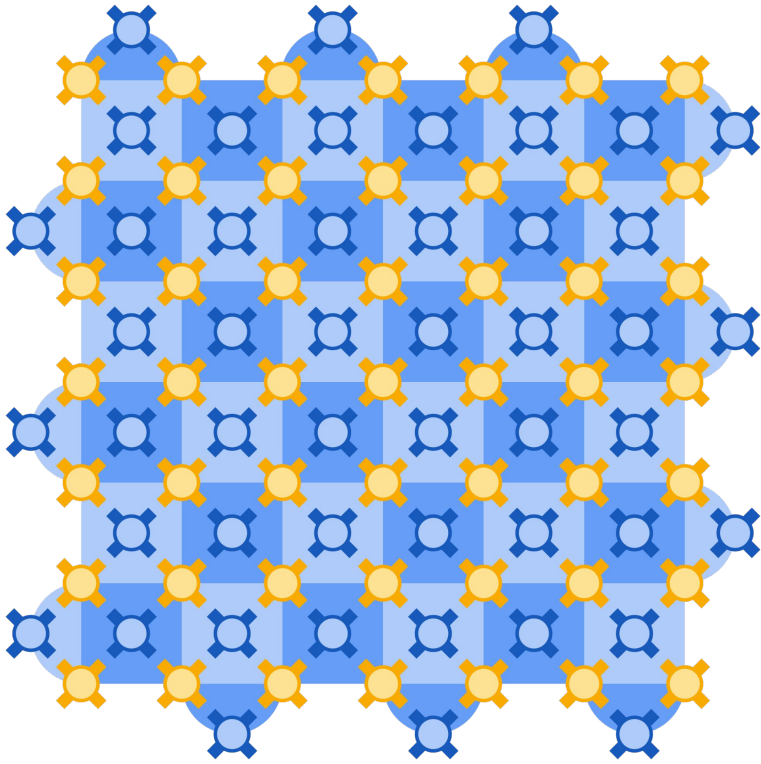

2D logical qubit protects against bit AND
phase: product of repetition codes

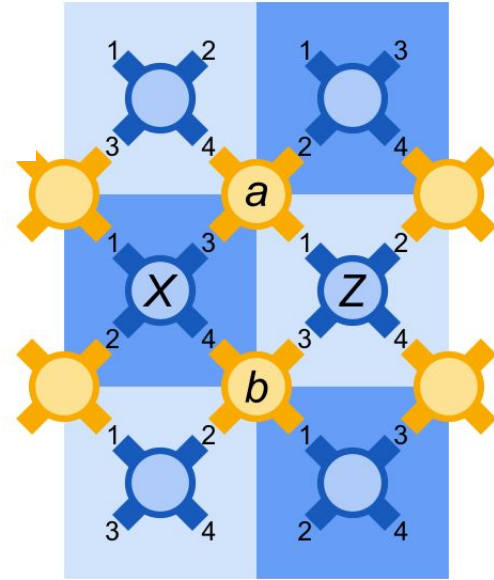

Quantum error correction

Good **logical** qubit from faulty **physical** qubits

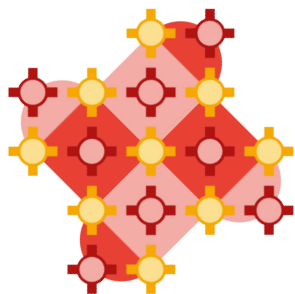

Distance-3
"1 error at a time"
17 qubits

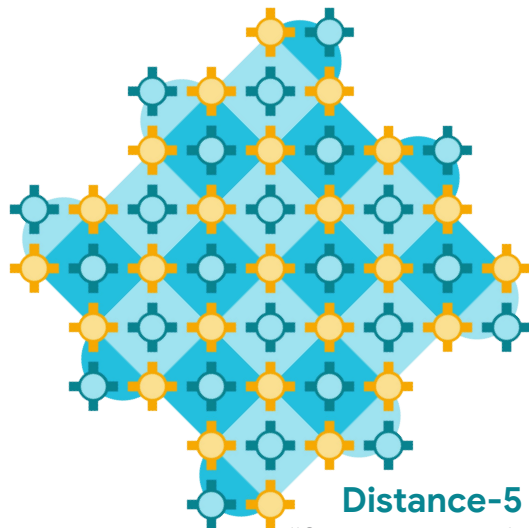

Distance-5
"2 errors at a time"
49 qubits

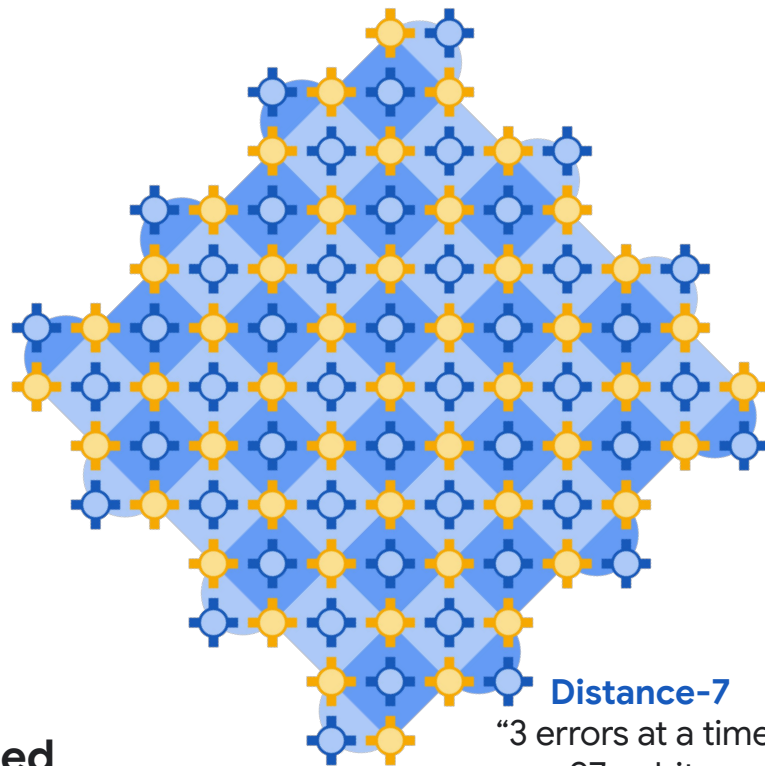

Distance-7
"3 errors at a time"
97 qubits

Logical error rate:

$$p_L \propto \Lambda^{-\frac{d+1}{2}}$$

...provided errors are **rare** and **uncorrelated**

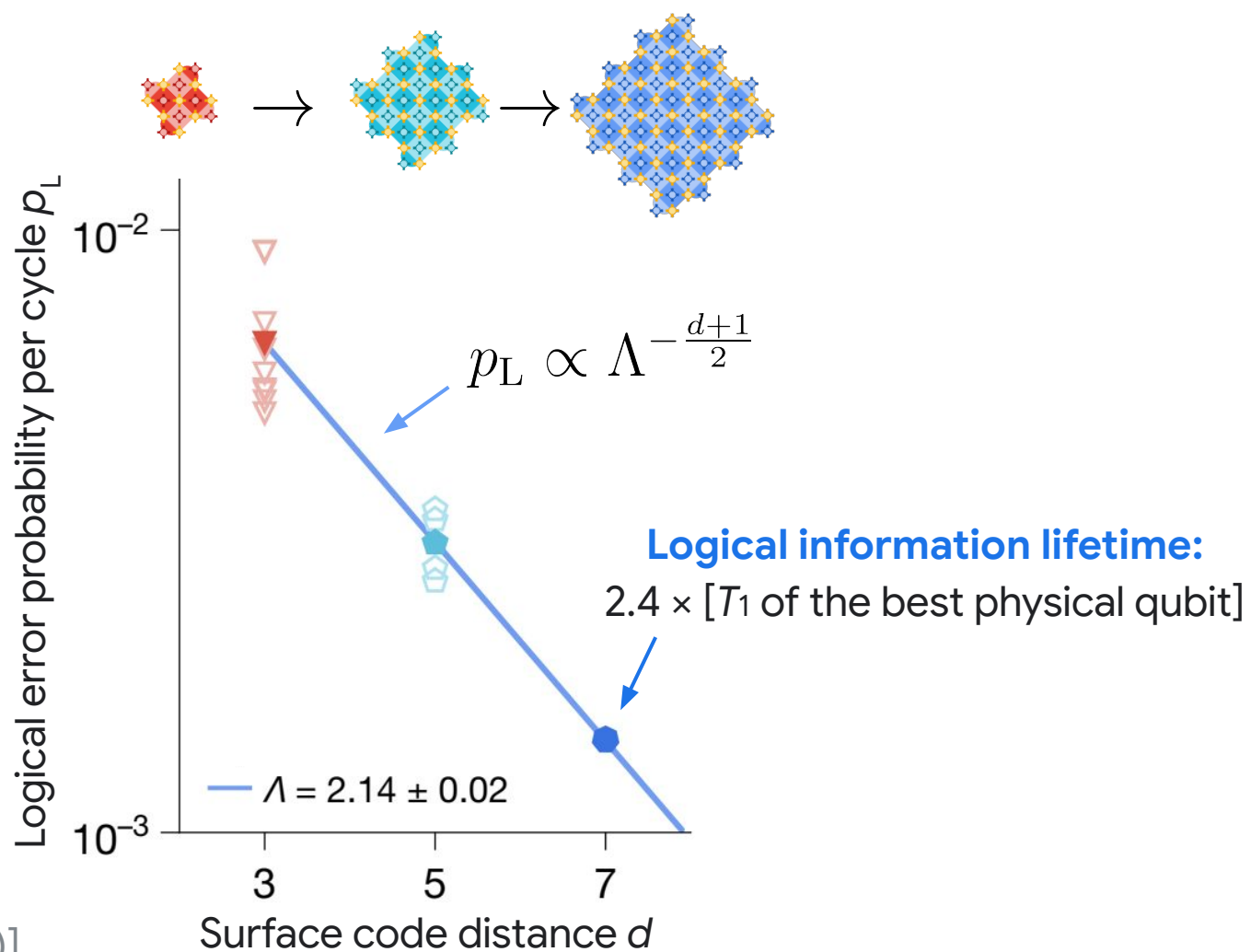

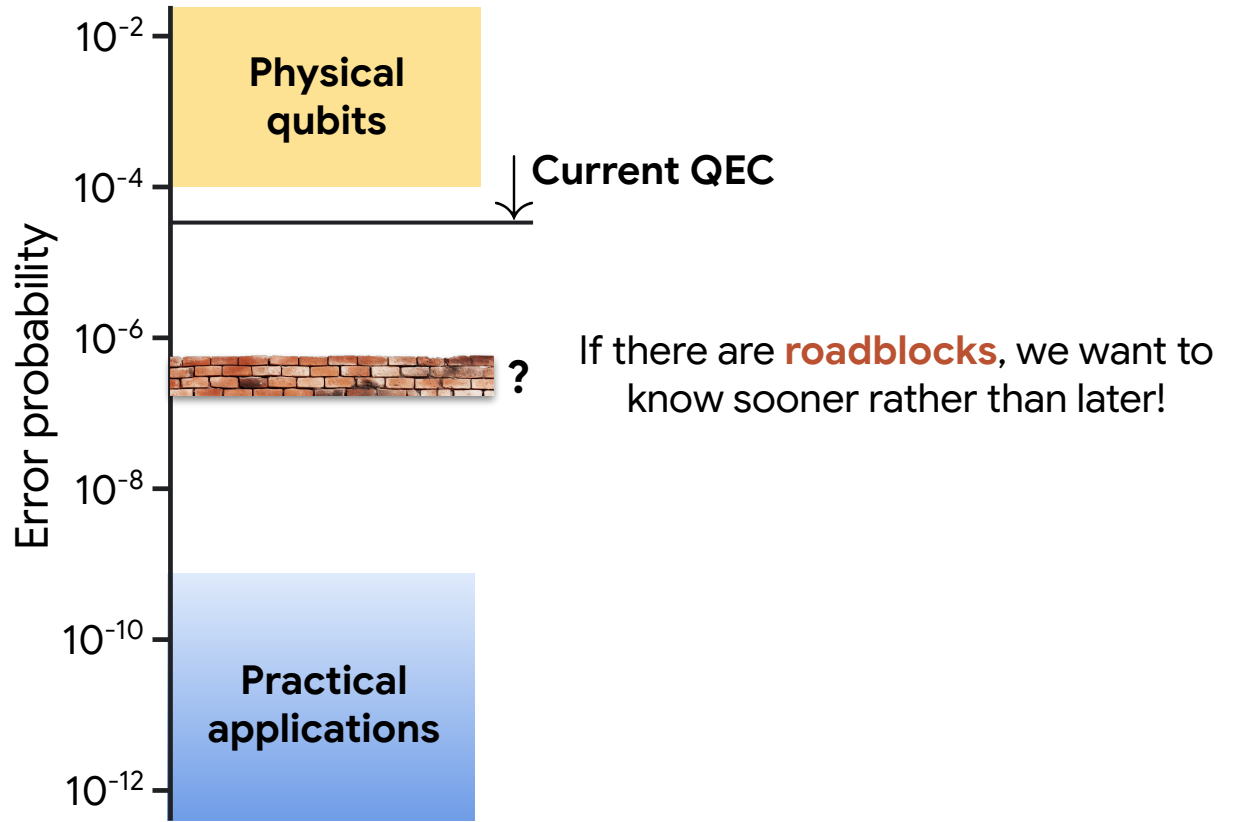

Another nice fact about the quantum repetition code: it's 1D, so you can get to much longer distances with far fewer qubits:

Use it to probe the super-low logical error regime!

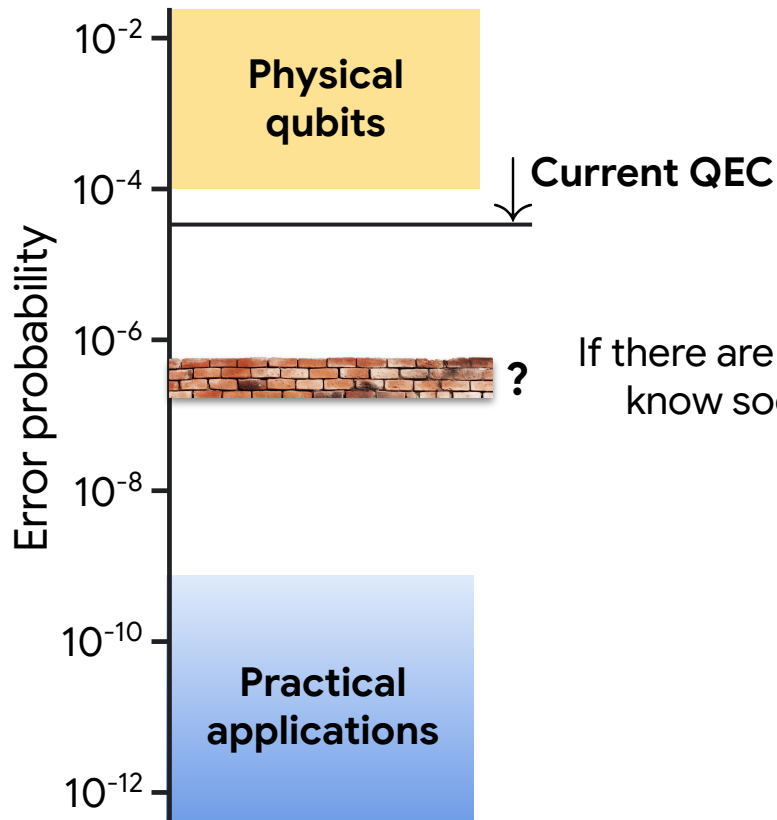

If there are **roadblocks**, we want to know sooner rather than later!

How does this prediction work in practice?

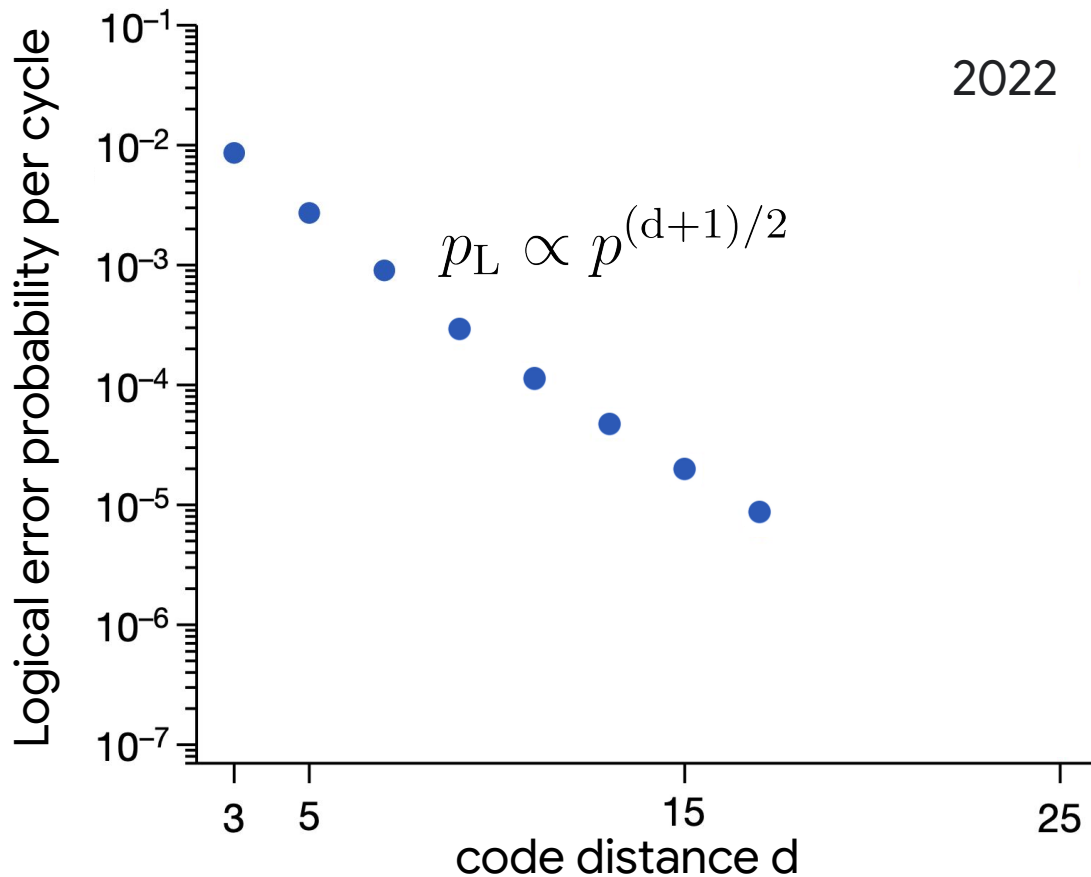
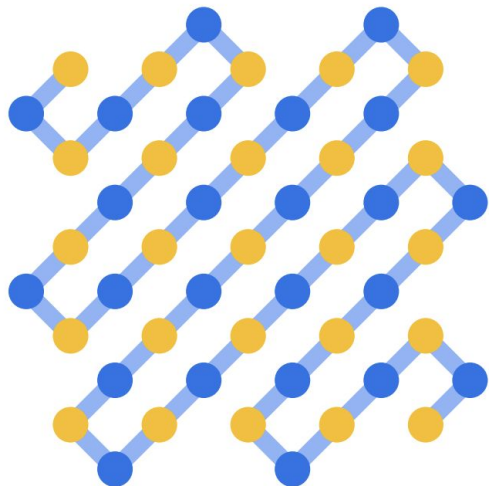

2022

How does this prediction work in practice?

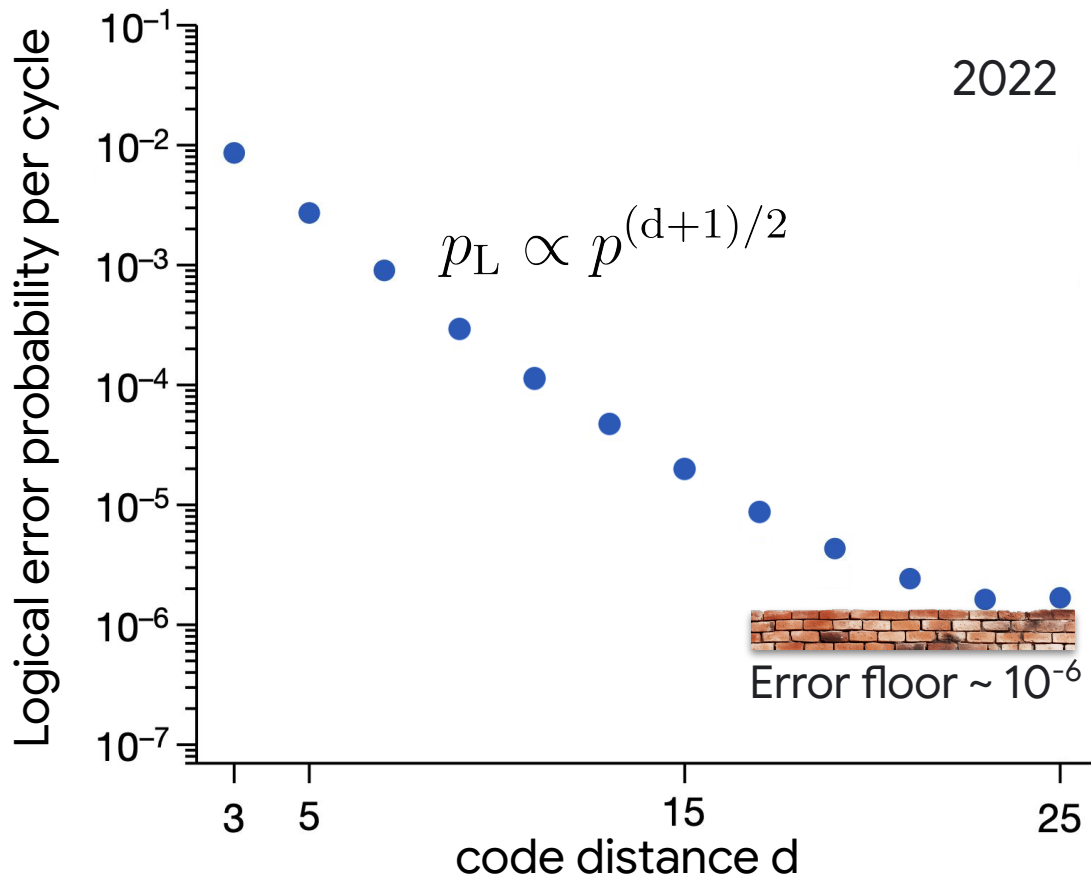
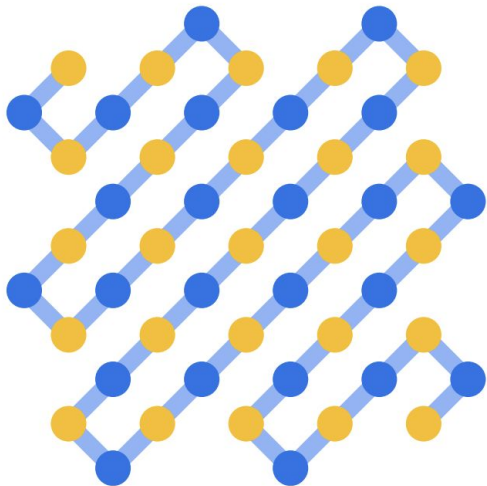

How does this prediction work in practice?

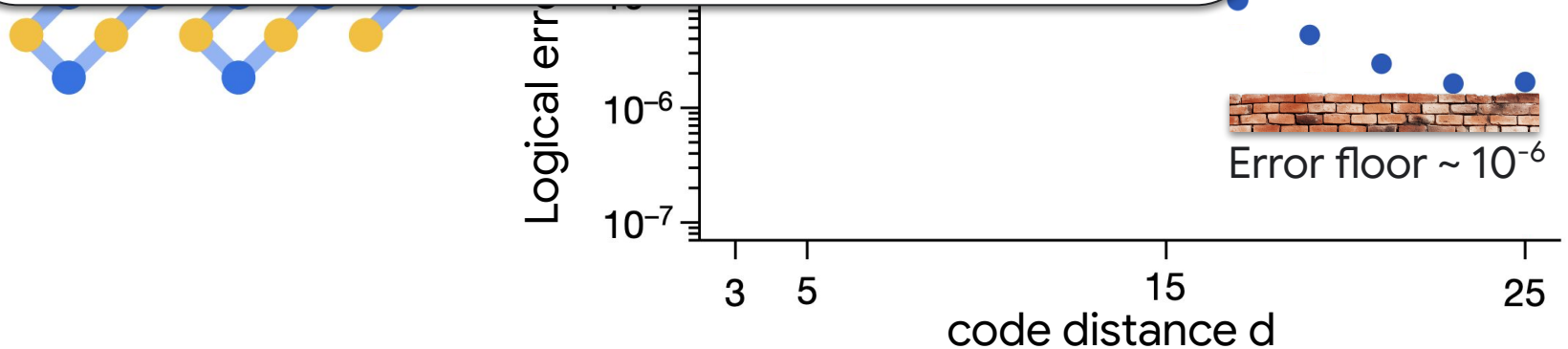
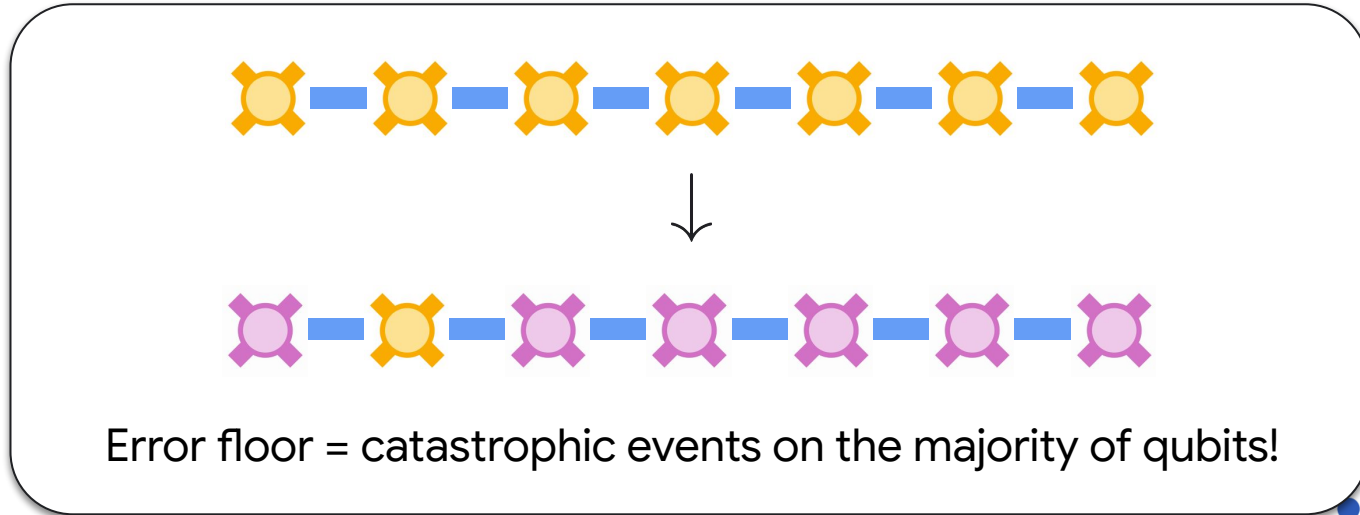

Origin of bursts: impacts of radioactive particles

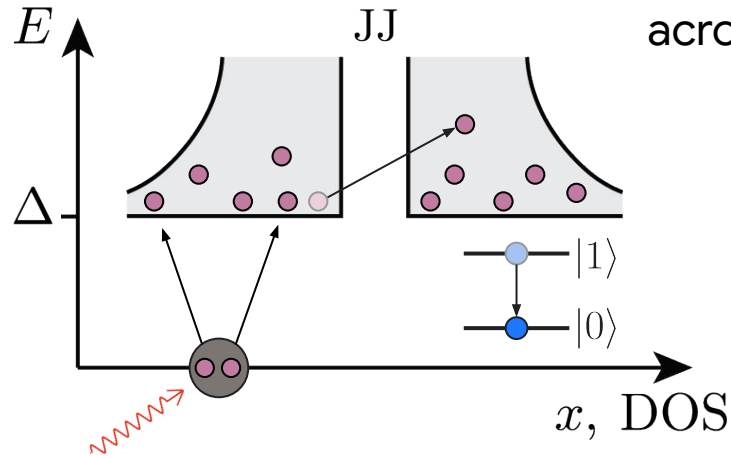
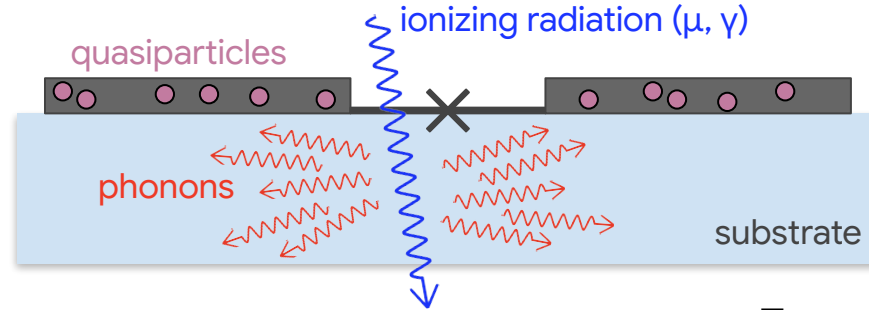

Tunneling of quasiparticles
across the Josephson junction

→ T_1 errors

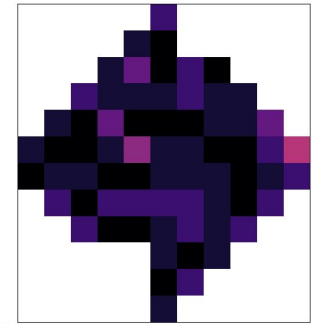

[C.D. Wilen et al (2021)]
[M. McEwen et al (2022)]
[P.M. Harrington et al (2024)]
...and many others

Origin of bursts: impacts of radioactive particles

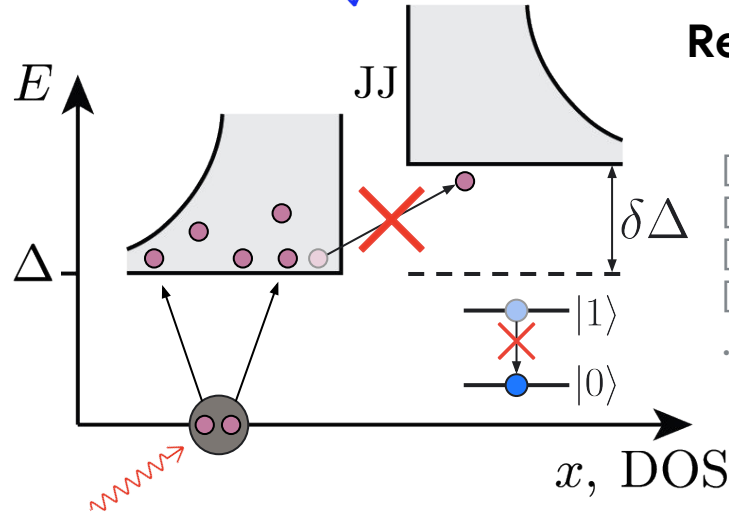
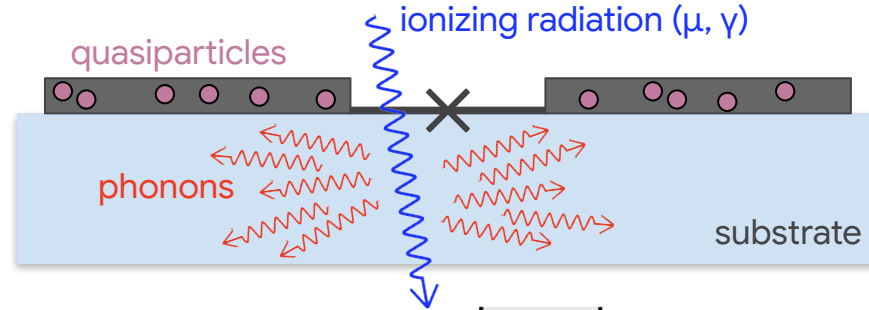

Remedy: potential barrier
for quasiparticles

- [T. Connolly, P. Kurilovich et al (2024)]
- [S. Diamond et al (2022)]
- [P. Kamenov et al (2023)]
- [H. Nho, et al (2025)]

...

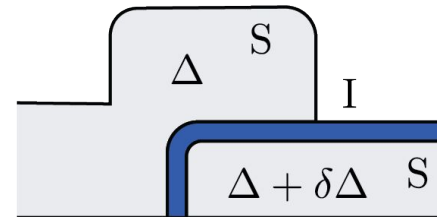

- [C.D. Wilen et al (2021)]
- [M. McEwen et al (2022)]
- [P.M. Harrington et al (2024)]
- ...and many others

Correlated error bursts in a gap engineered qubit array

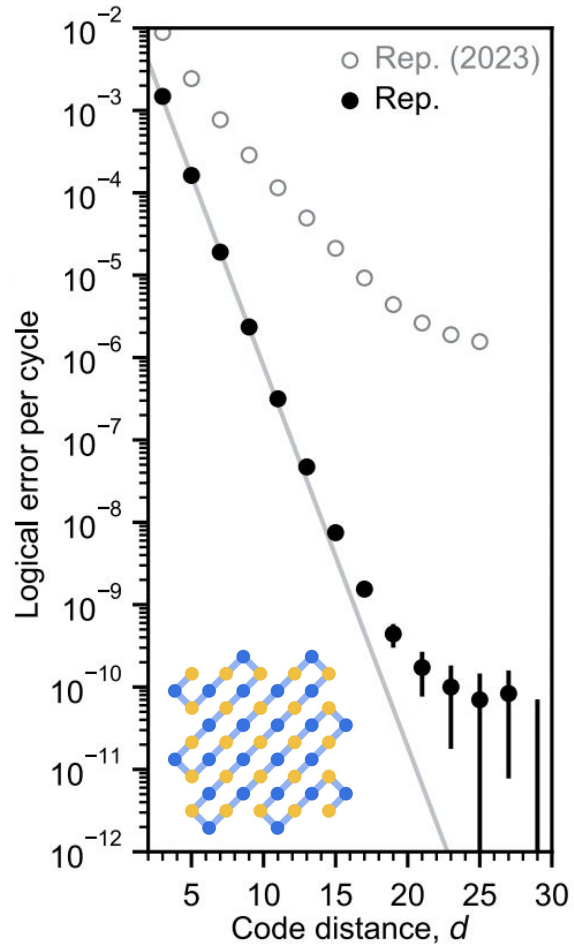

[Nature **638**, 920 (2025)]

Correlated error bursts in a gap engineered qubit array

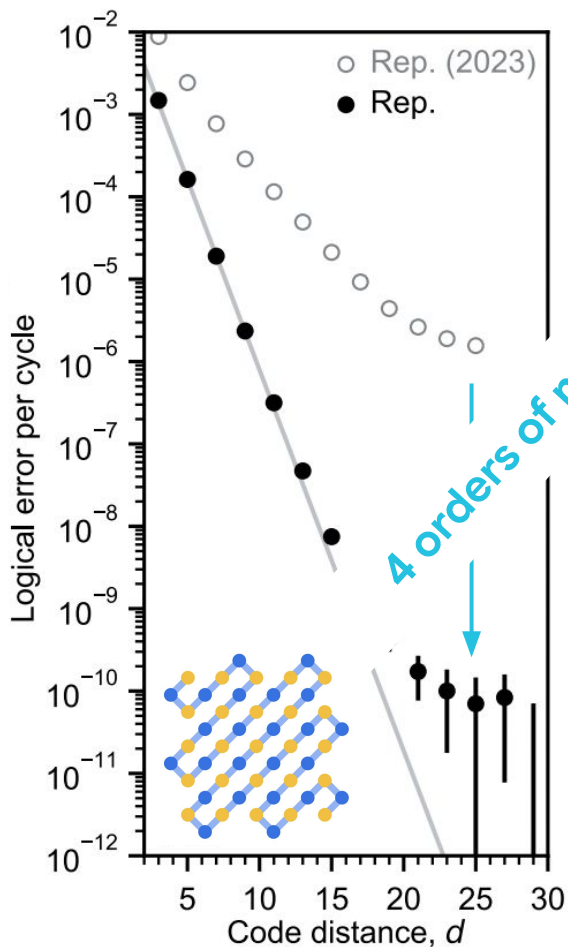

Good news: error floor $\sim 10^{-10}$

~ 1 logical error / hour

[Nature **638**, 920 (2025)]

Correlated error bursts in a gap engineered qubit array

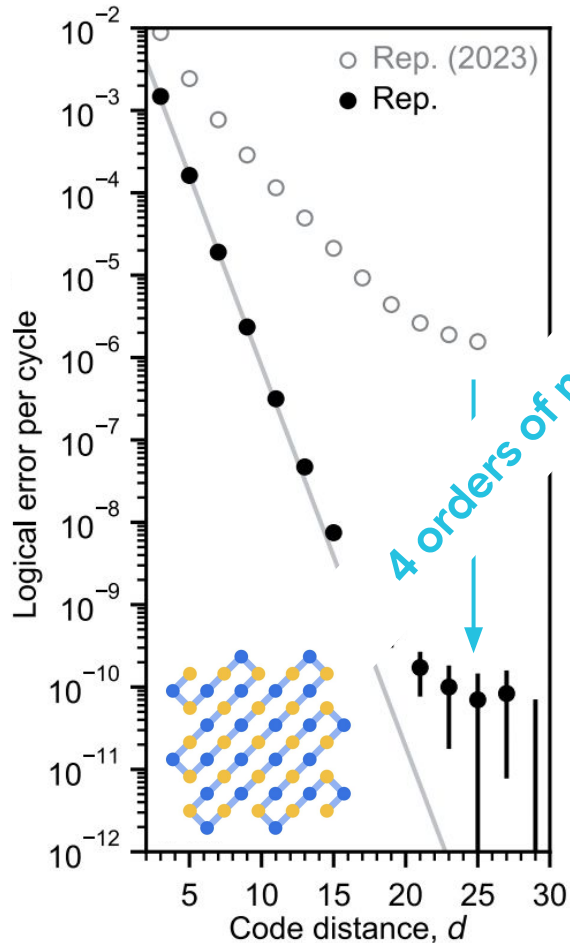

Good news: error floor $\sim 10^{-10}$

~ 1 logical error / hour

Bad news: the floor is still there!

[Nature **638**, 920 (2025)]

Correlated error bursts in a gap engineered qubit array

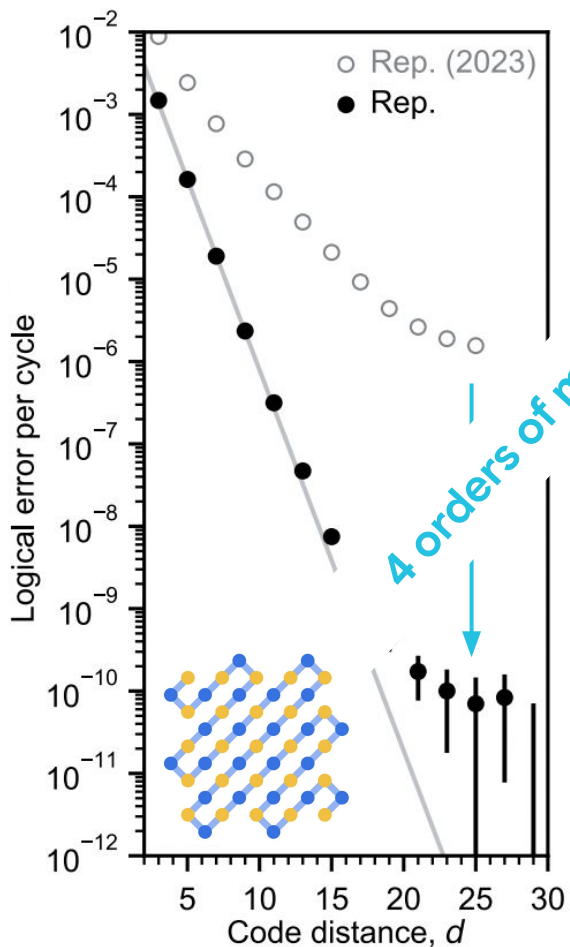

Good news: error floor $\sim 10^{-10}$

~ 1 logical error / hour

Bad news: the floor is still there!

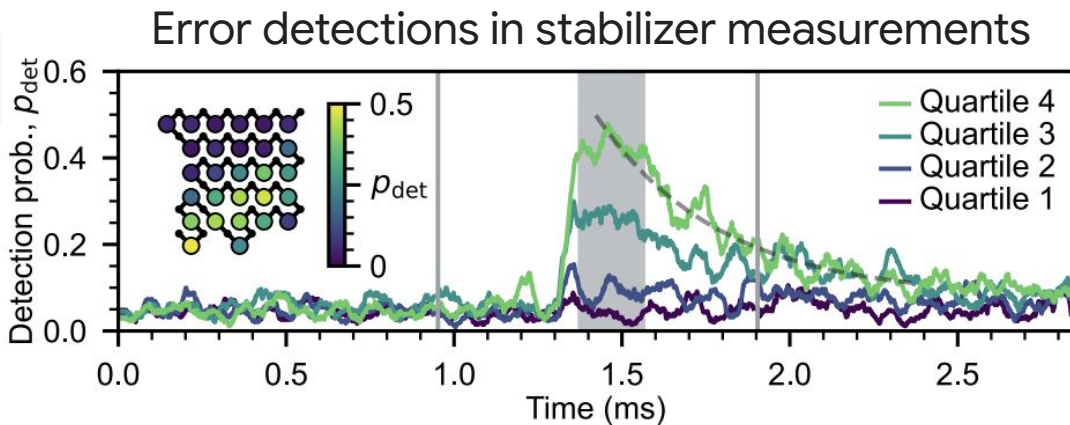

[Nature 638, 920 (2025)]

High repetition rate array-wide error checks

On every qubit on the grid, cycle the error check sequence:

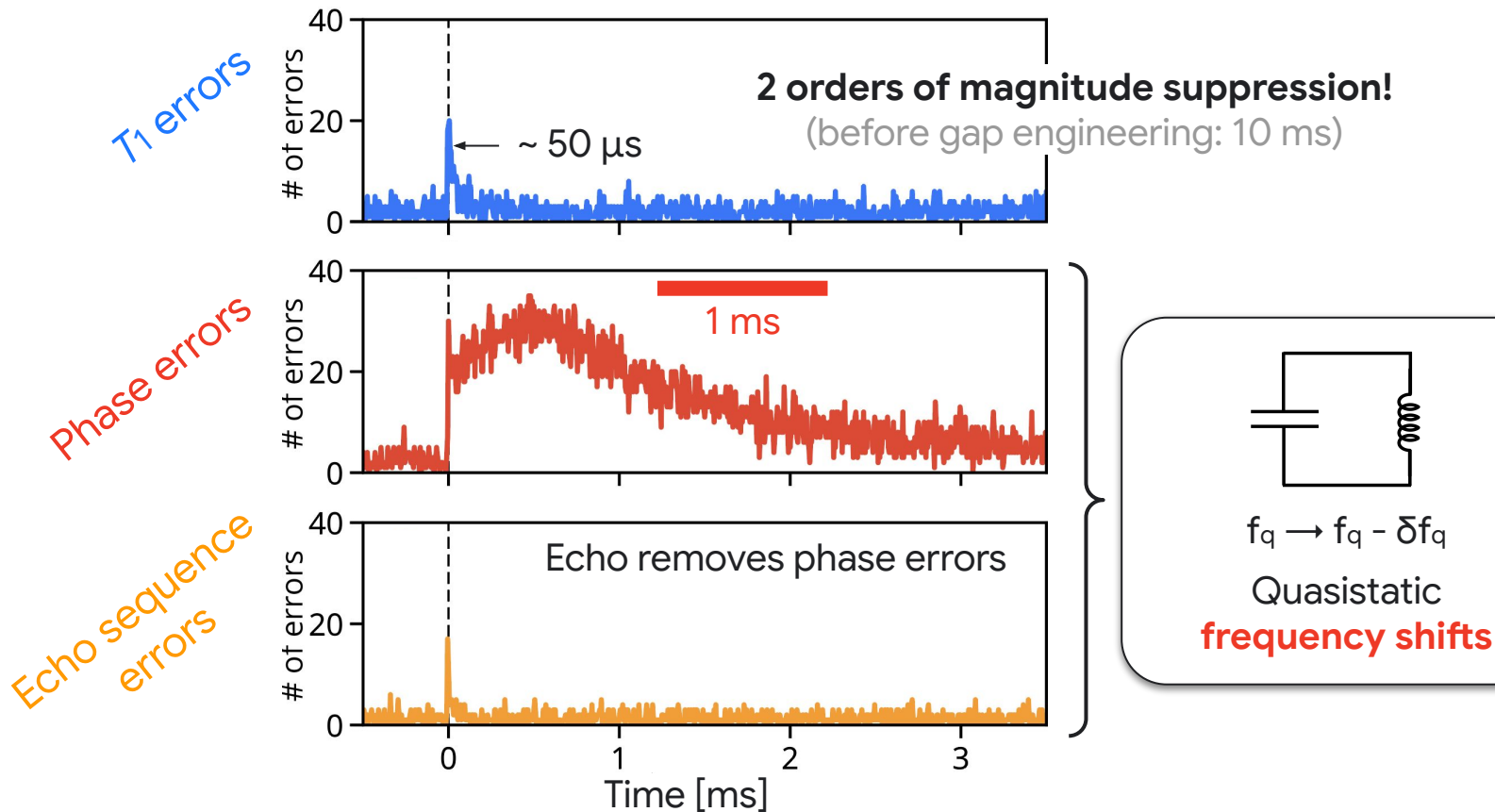

Time-resolved frequency shift measurements (tomography)

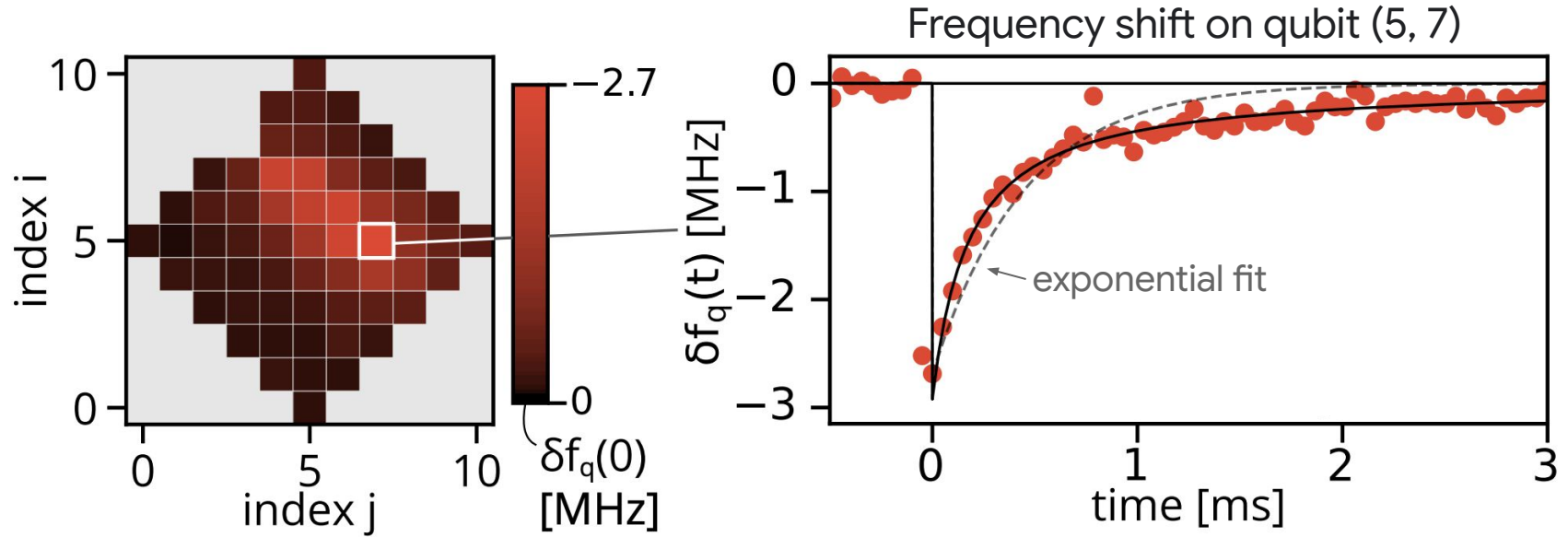

Main features:

- (i) Always negative, ~ 1 MHz
- (ii) Non-exponential recovery, takes ~ 1 ms

Physical picture

$$E_J \rightarrow E_J - \delta E_J$$

$$f_q \rightarrow f_q - \delta f_q$$

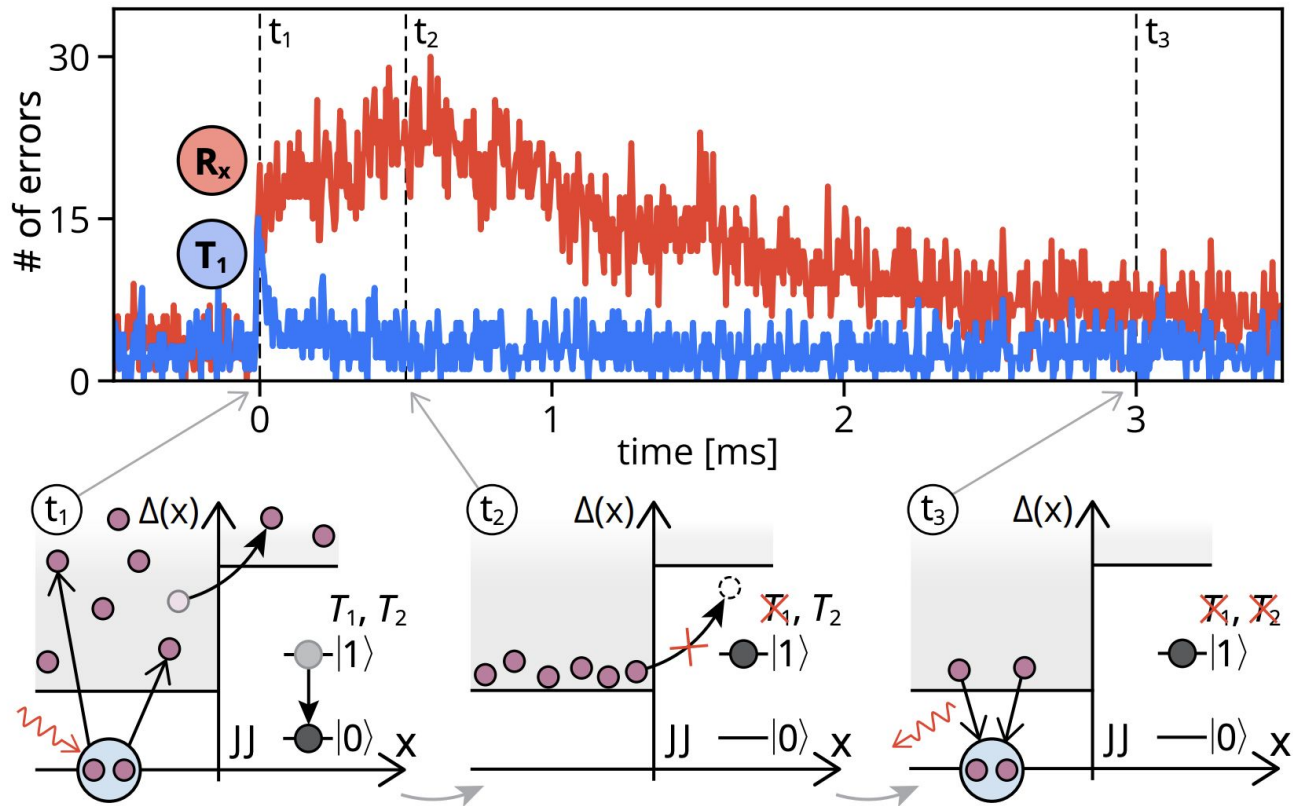

Bursts in gap engineered devices:

Transient T_1 errors ($\sim 50 \mu\text{s}$) and negative, long lasting ($\sim 1 \text{ ms}$) frequency shifts

“Hot” QPs

“Cold” QPs

Correlating phase errors with QEC error detections

Repetition code on one part of the array

Phase and T_1 error checks on the complementary part

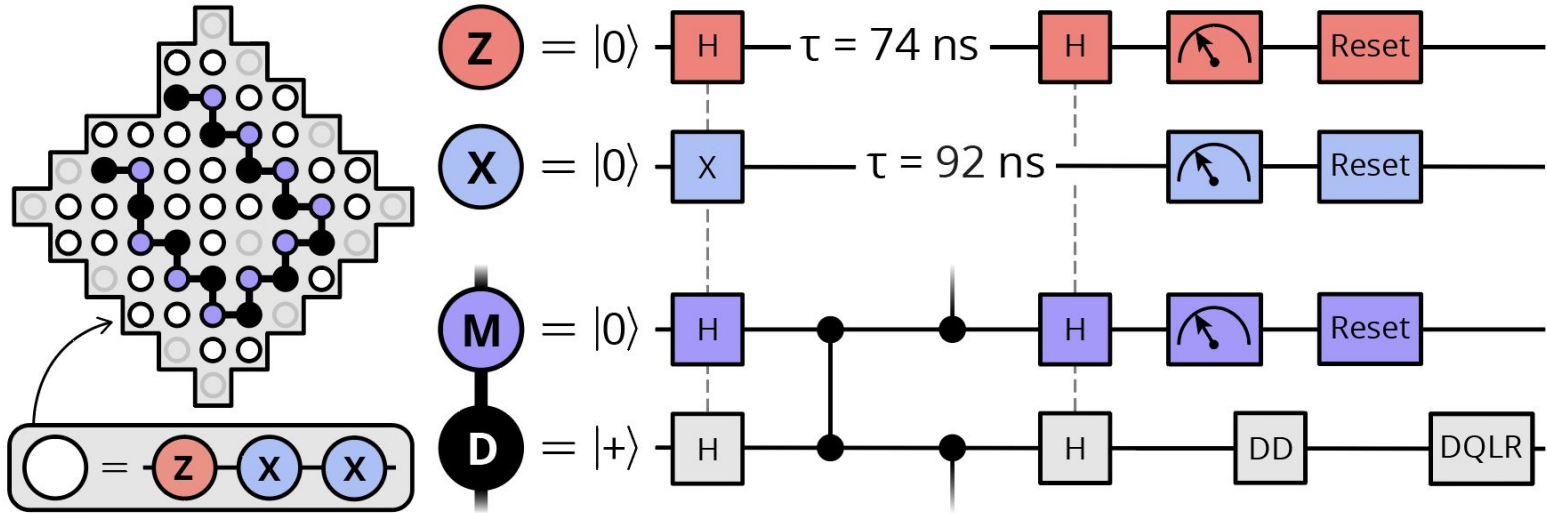

Correlating phase errors with QEC error detections

Repetition code on one part of the array

Phase and T_1 error checks on the complementary part

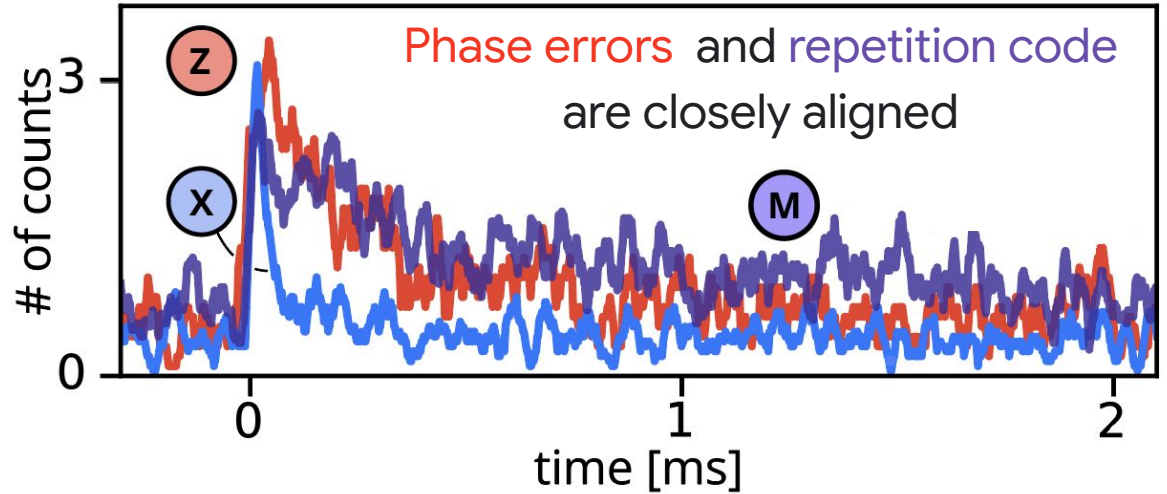
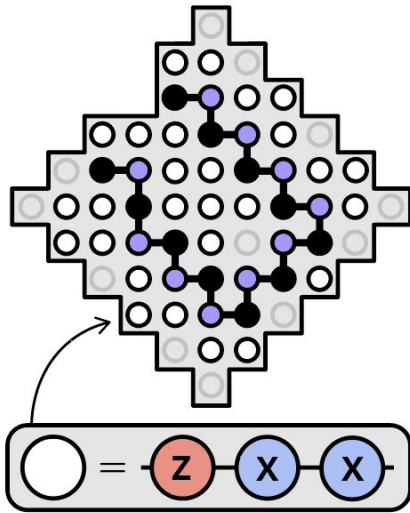

[see arXiv:2506.18228 for details]

Correlating phase errors with QEC error detections

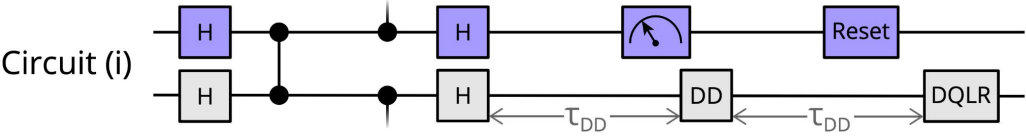

[see arXiv:2506.18228 for details]

Correlating phase errors with QEC error detections - add echos?

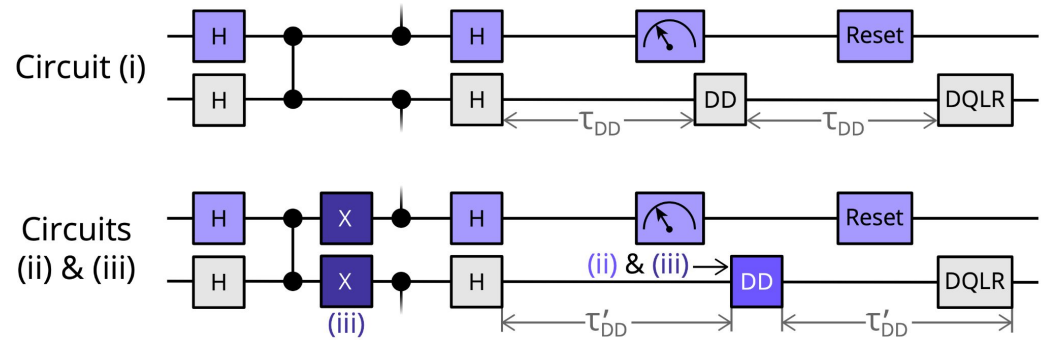

[see arXiv:2506.18228 for details]

Correlating phase errors with QEC error detections - add echos?

Adding an **echo** (and **centering DD**) collapses the QEC error detection onto the **T_1 error** burst

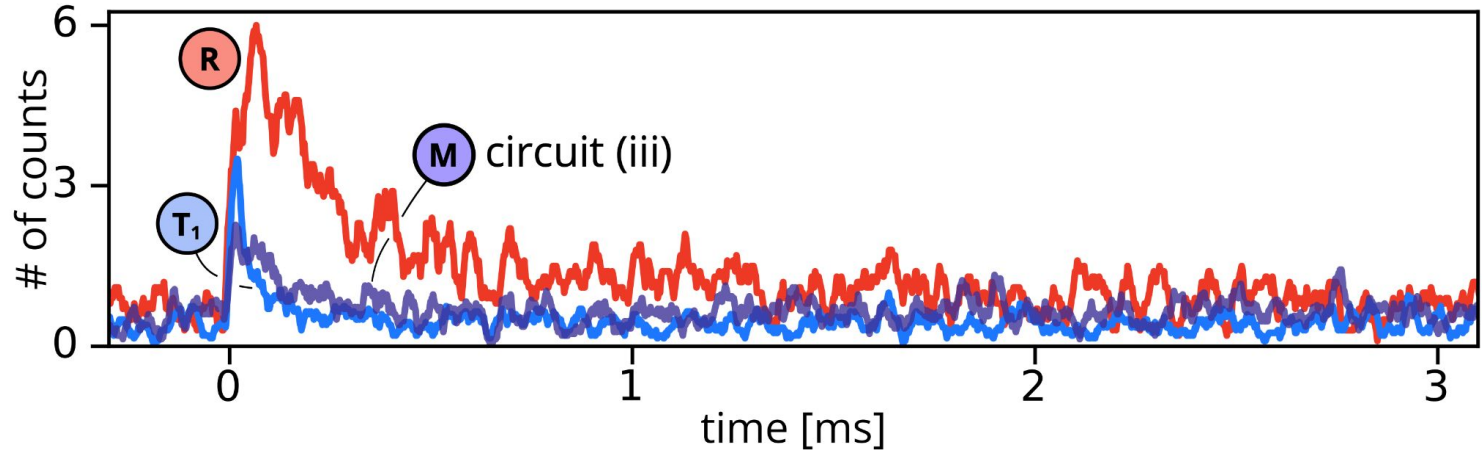
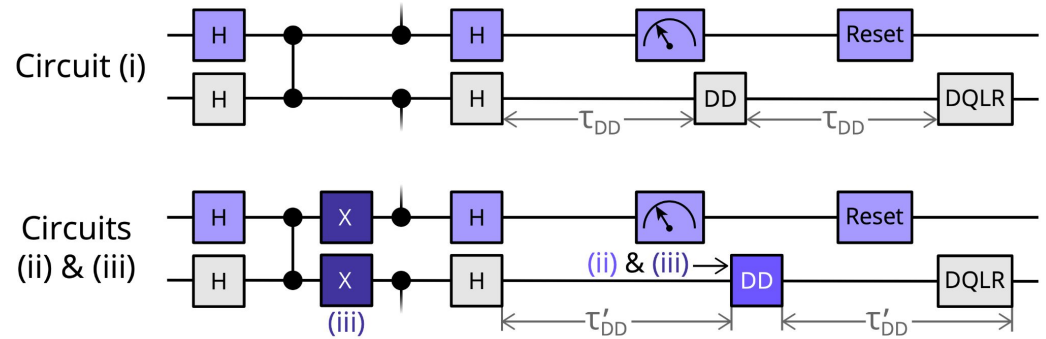

[see arXiv:2506.18228 for details]

Costs of remaining T1 burst

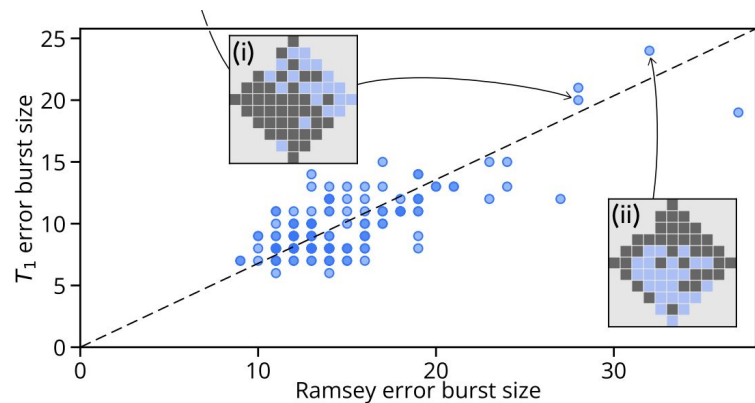
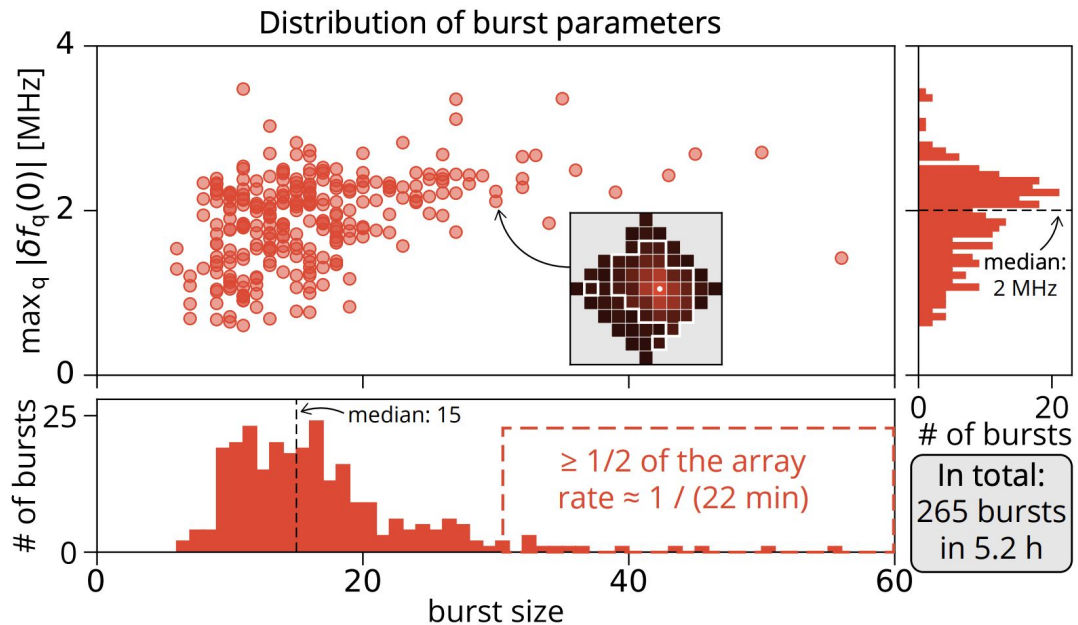

Costs of remaining T1 burst

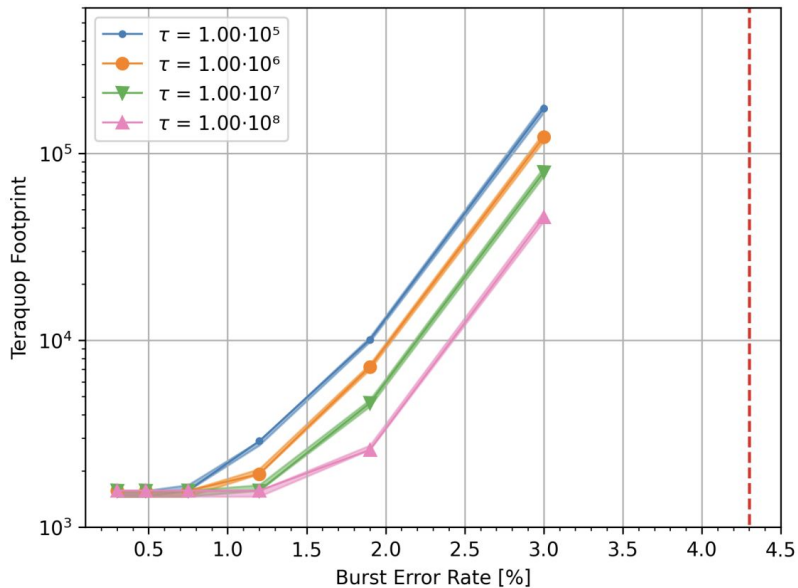
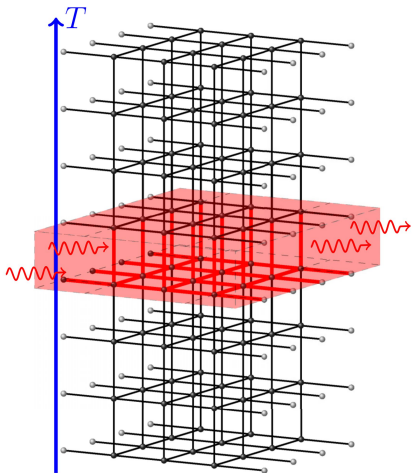

Still want burst to be
as SMALL in time
and space as
possible

[see S. Tan et al (2026)]

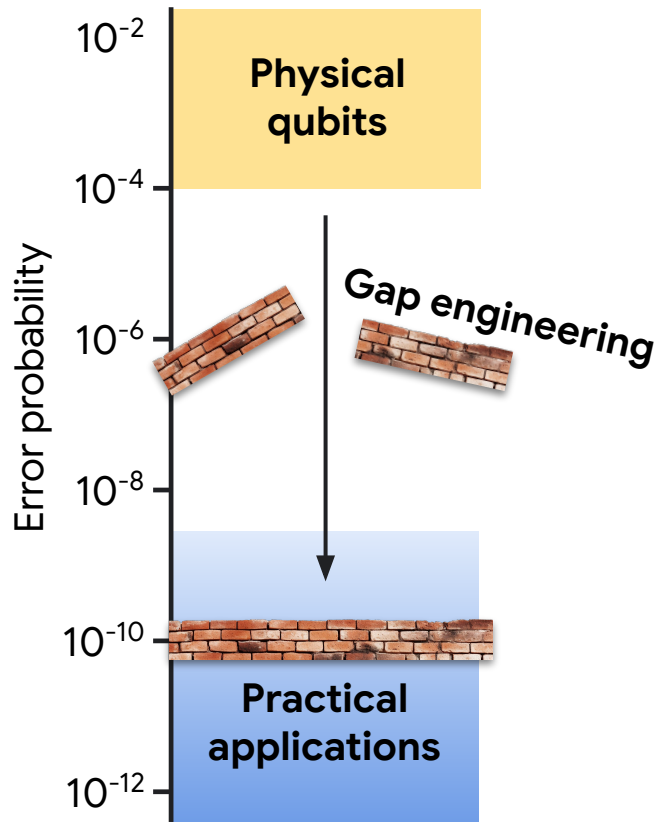

[Image by pngtree.com]

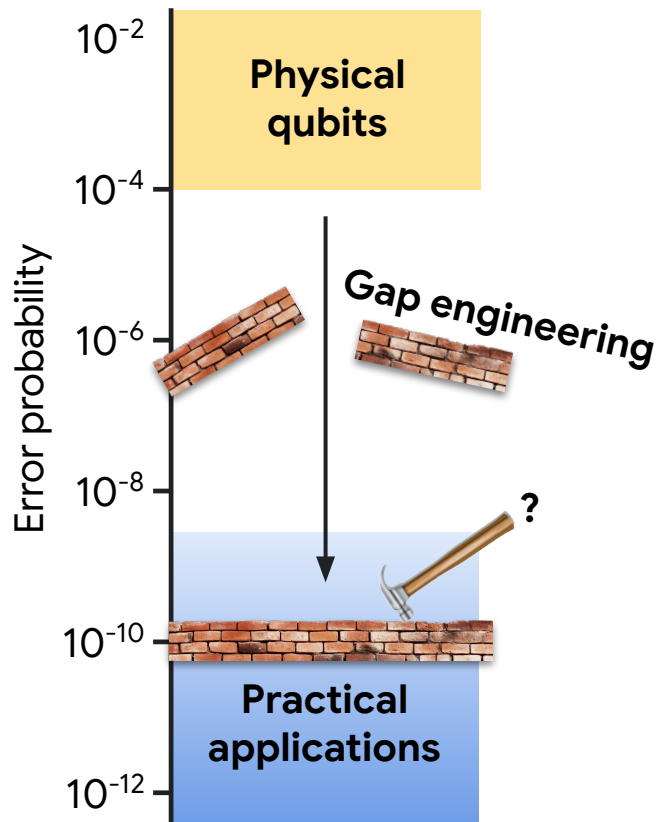

[Image by pngtree.com]

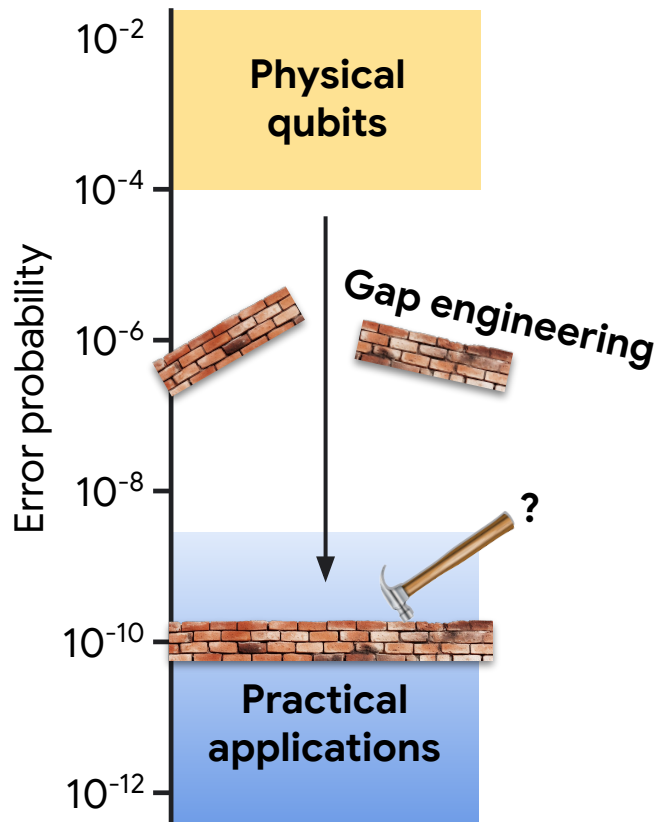

[Image by pngtree.com]

Quasiparticle traps

[see, e.g., R.-P. Riwar et al (2016, 2019)]

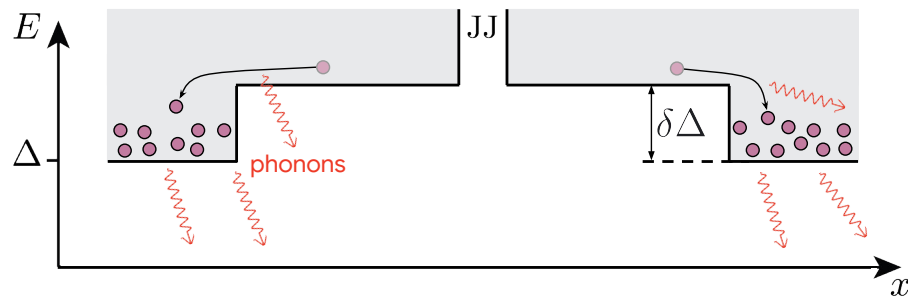

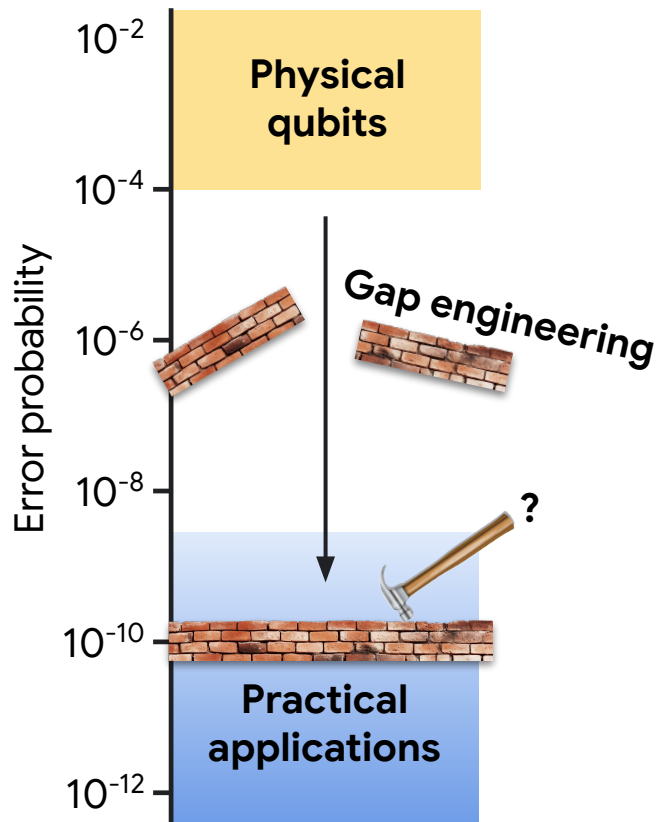

[Image by pngtree.com]

Phonon traps [see V. Iaia et al (2022)]

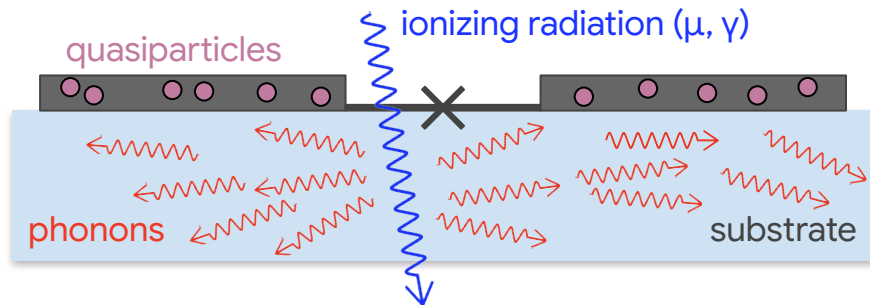

Quasiparticle traps

[see, e.g., R.-P. Riwar et al (2016, 2019)]

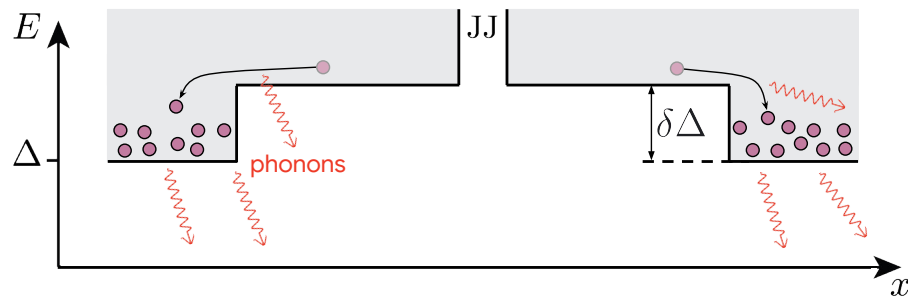

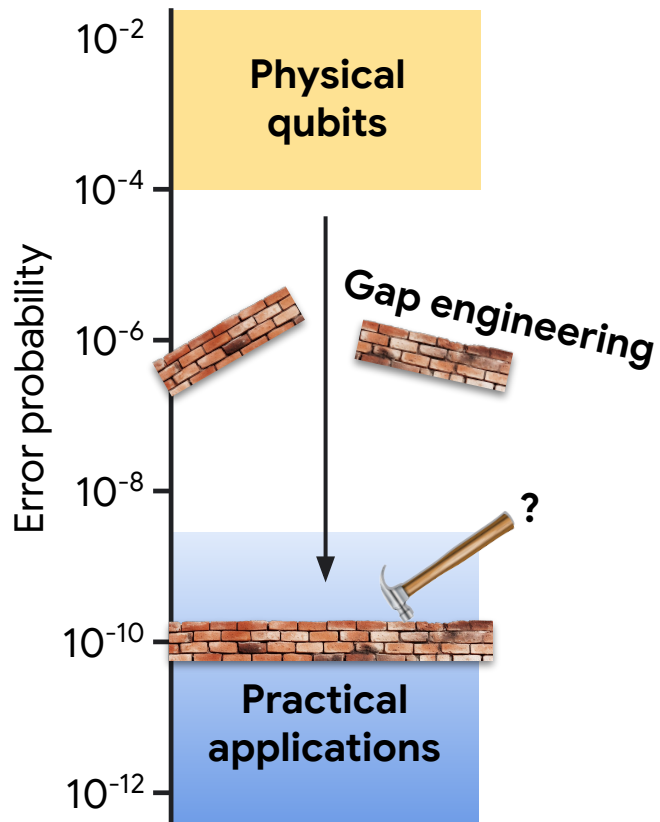

[Image by pngtree.com]

Phonon traps [see V. Iaia et al (2022)]

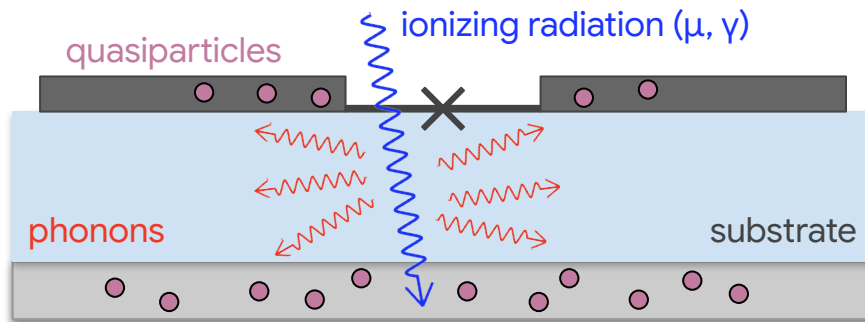

Quasiparticle traps

[see, e.g., R.-P. Riwar et al (2016, 2019)]

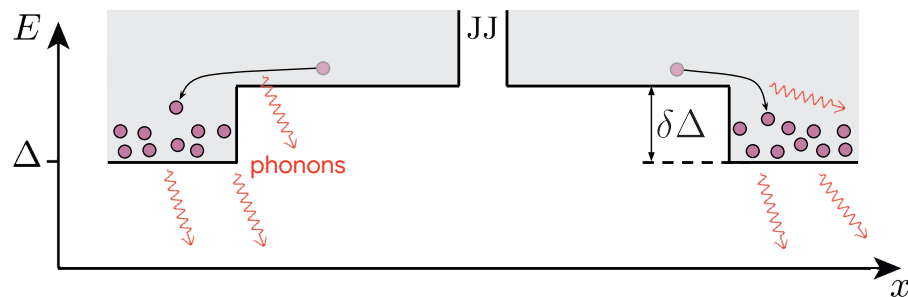

Summary

Radioactivity leads to error bursts in SC quantum processors (very bad for QEC)

We dramatically suppressed the problem in Willow chips using **gap engineering**

Some bursts remain; we know where they come from and have ideas for how to deal with them

Summary

Radioactivity leads to error bursts in SC quantum processors (very bad for QEC)

We dramatically suppressed the problem in Willow chips using **gap engineering**

Some bursts remain; we know where they come from and have ideas on how to deal with them

Vlad Kurilovich



Alex Opremcak



Matt McEwen



...and many others!

Summary

Background radiation leads to error bursts in SC quantum processors

Old devices (pre-Willow)

No gap engineering

Main type of error bursts:

Bit flip errors

(qubit energy relaxation)

Burst duration:

~10 ms

Repetition code error floor:

10^{-6}

New devices (Willow)

Gap engineered qubits

Main type of error bursts:

Phase flips errors

(qubit frequency shifts)

Burst duration:

~1 ms

Repetition code error floor:

10^{-10}

Library of bursts

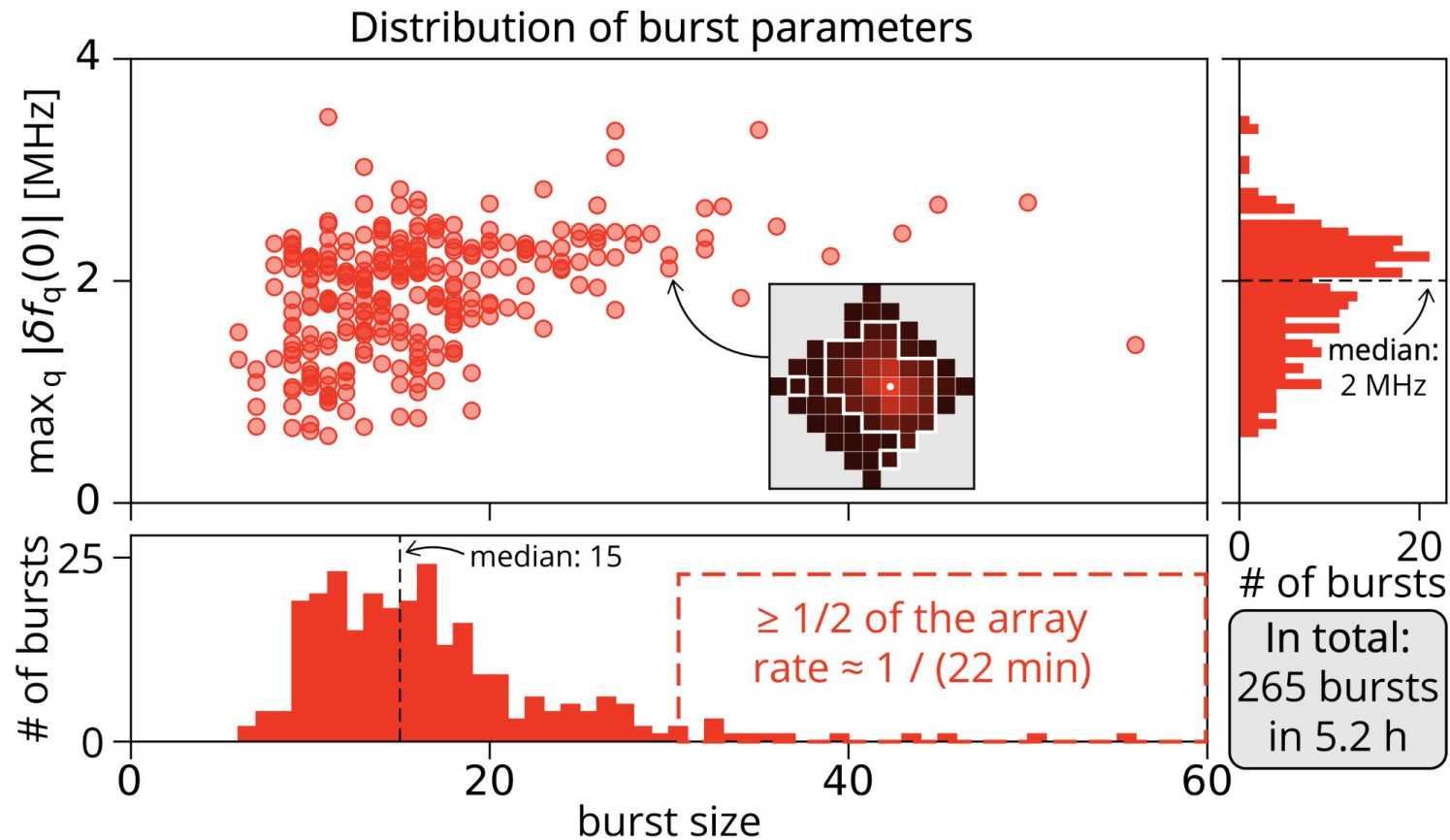

Library of bursts

(a)

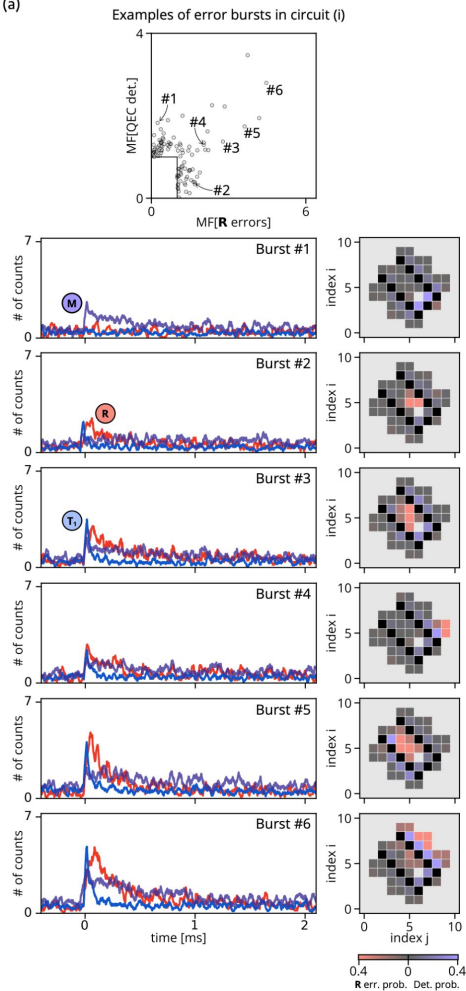

(b)

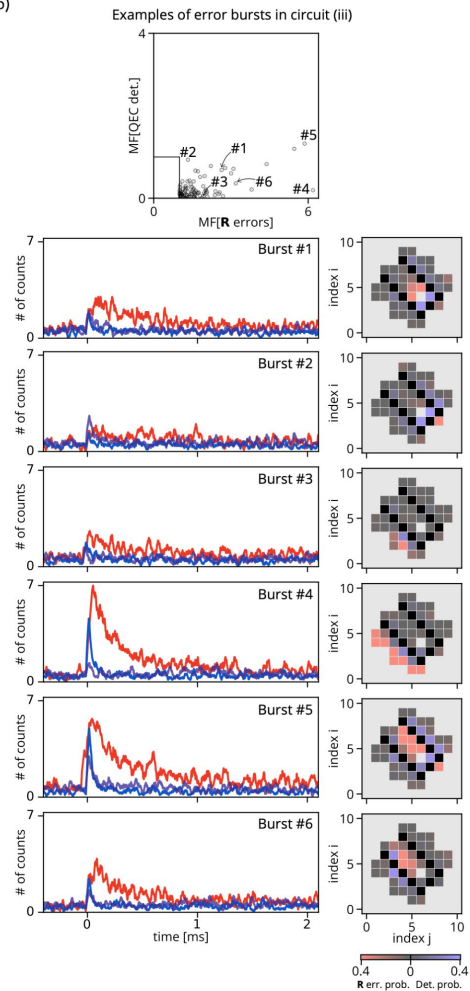

What about excitation errors?

“Hot” QPs should be able to not only relax the qubit (T_1 errors), but also excite it!

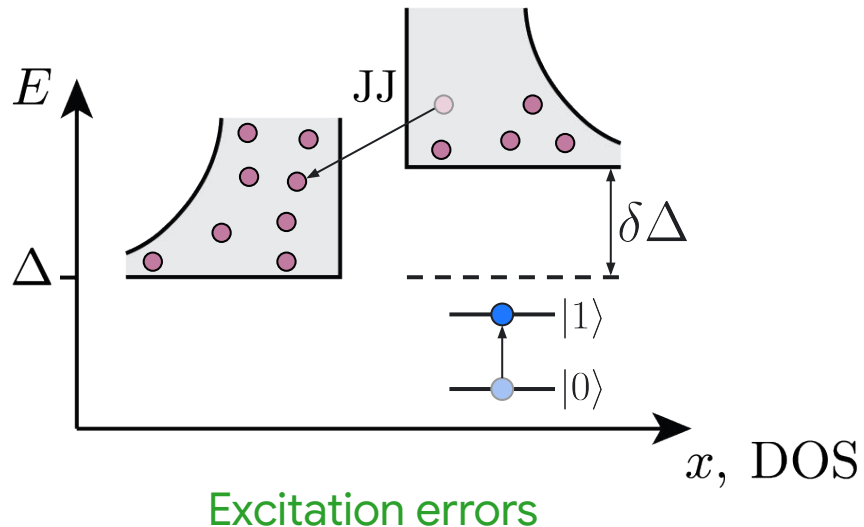
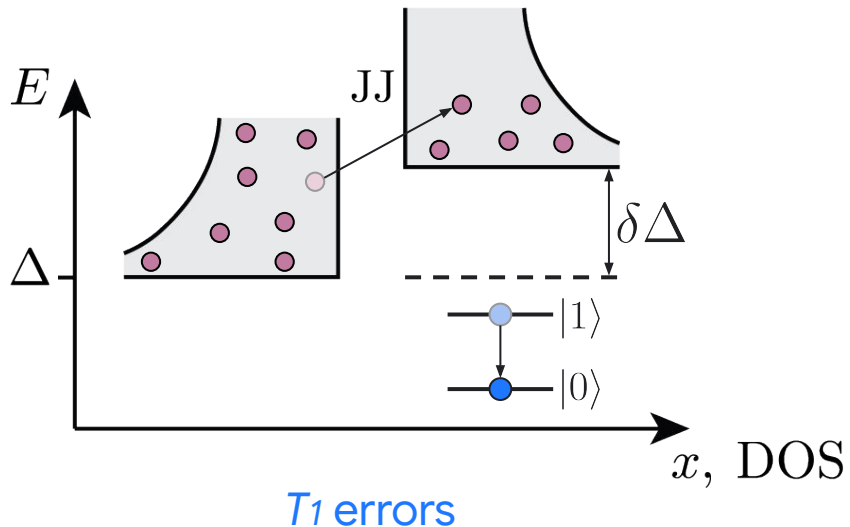

What about excitation errors?



What about excitation errors?

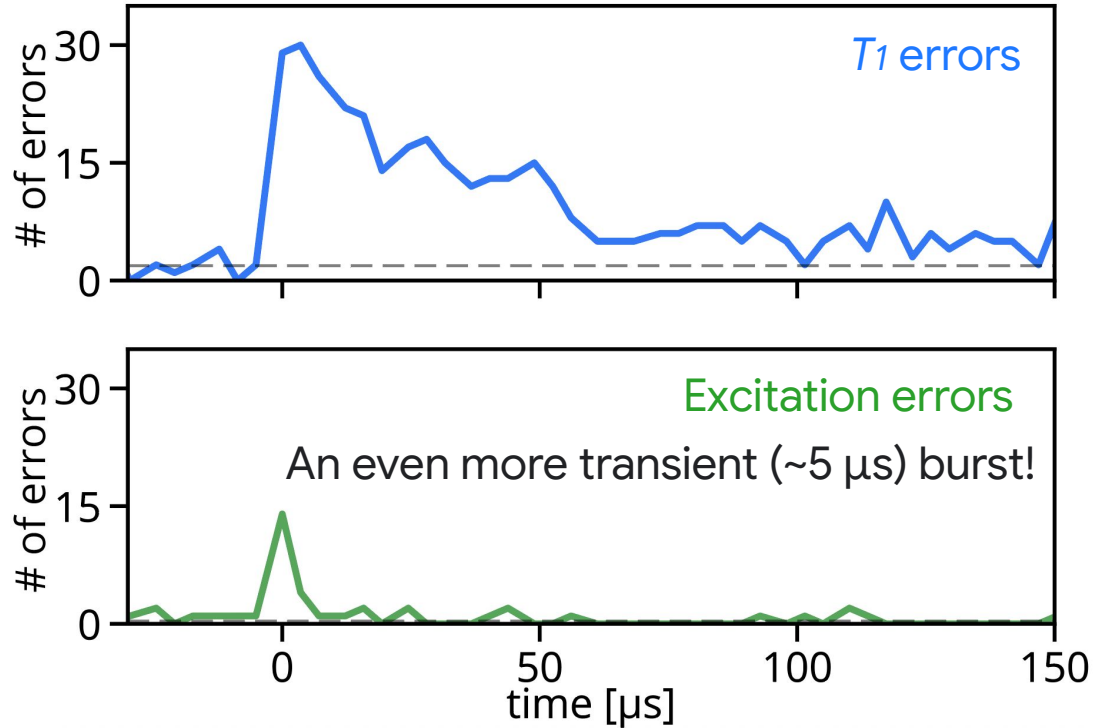

What about excitation errors?

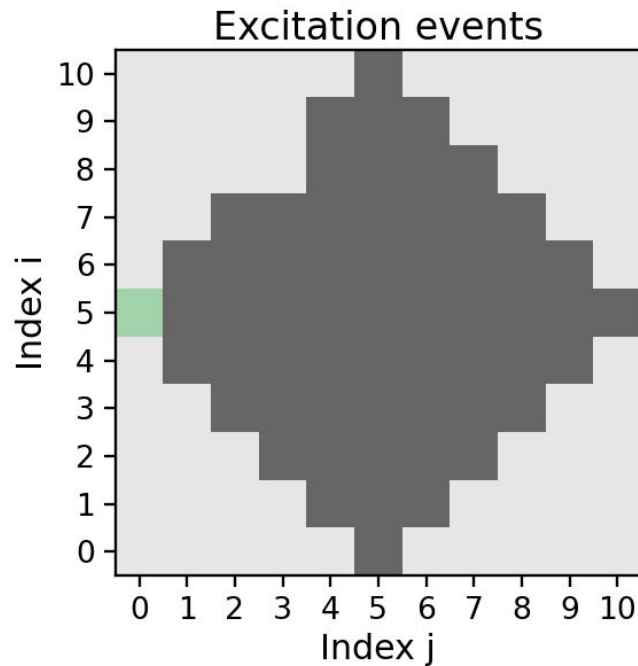
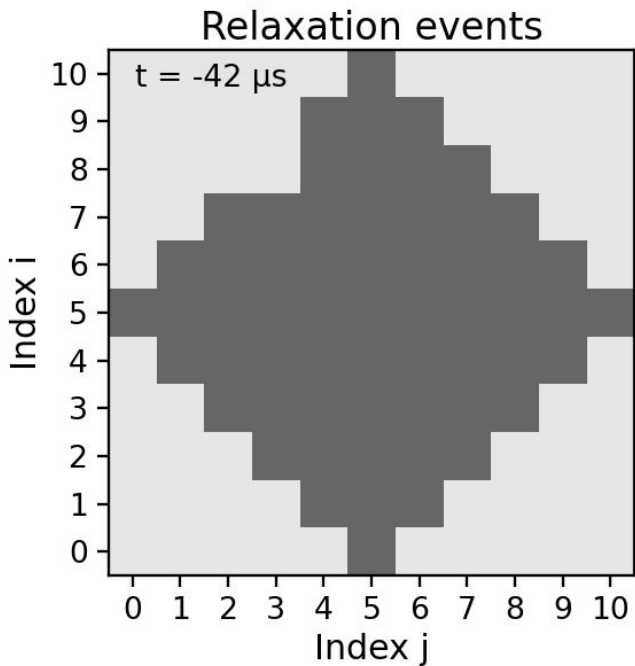

What about excitation errors?

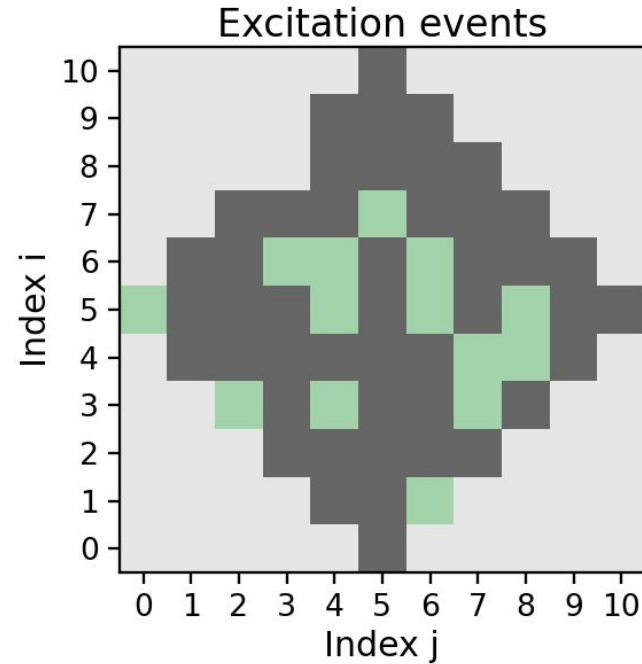
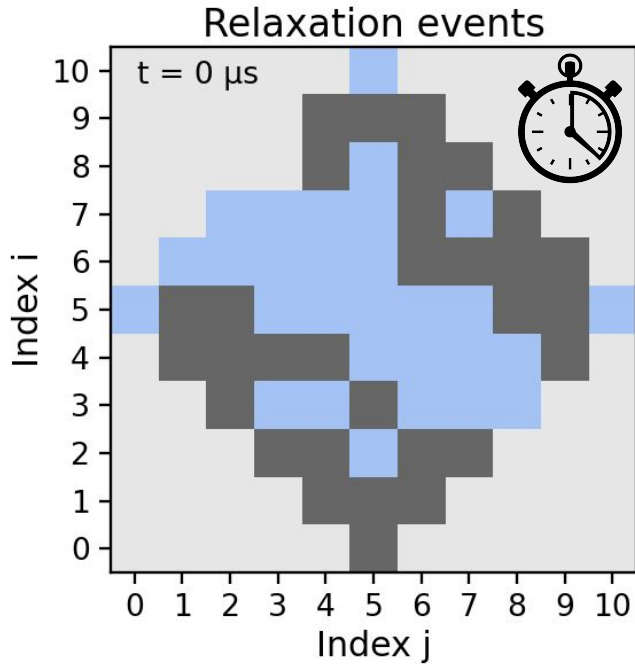

Bursts in gap engineered devices:

Negative, long lasting (~ 1 ms) frequency shifts + transient T_1 errors (~ 50 μ s)

[*Bonus*: weak, very transient excitation errors (~ 5 μ s)]

Superconducting qubits reminder

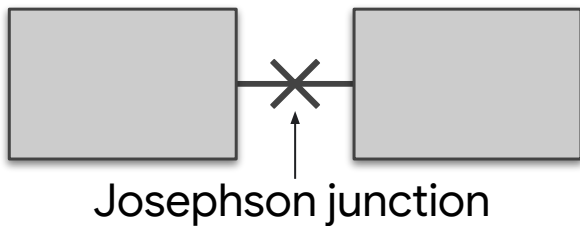

\approx

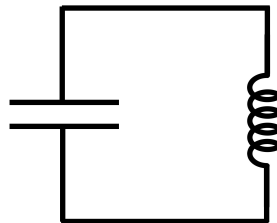

Weakly nonlinear
resonator
(junction = inductor)

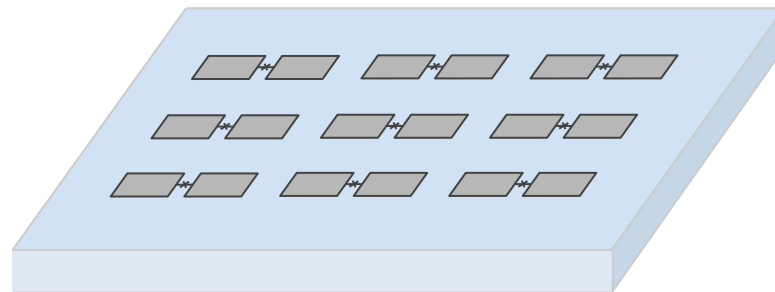
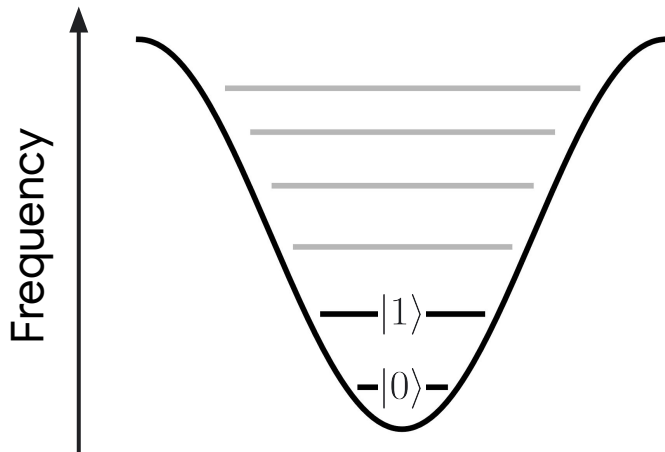

Silicon substrate

[Koch et al., PRA **76** 042319 (2007)]

[Schuster Thesis (Yale, 2007); Kelly Thesis (UCSB, 2015)]