

# Transformer Updates

DMRadio collaboration meeting

10/8/25

1. Amplifier Noise & the tunable transformer

2. Transformer testing setup

3. New filter design

4. 20mK hutch design

Why do we want a  
transformer?

# 50L noise sources

Imprecision noise- white  
Backaction – resonator line shape

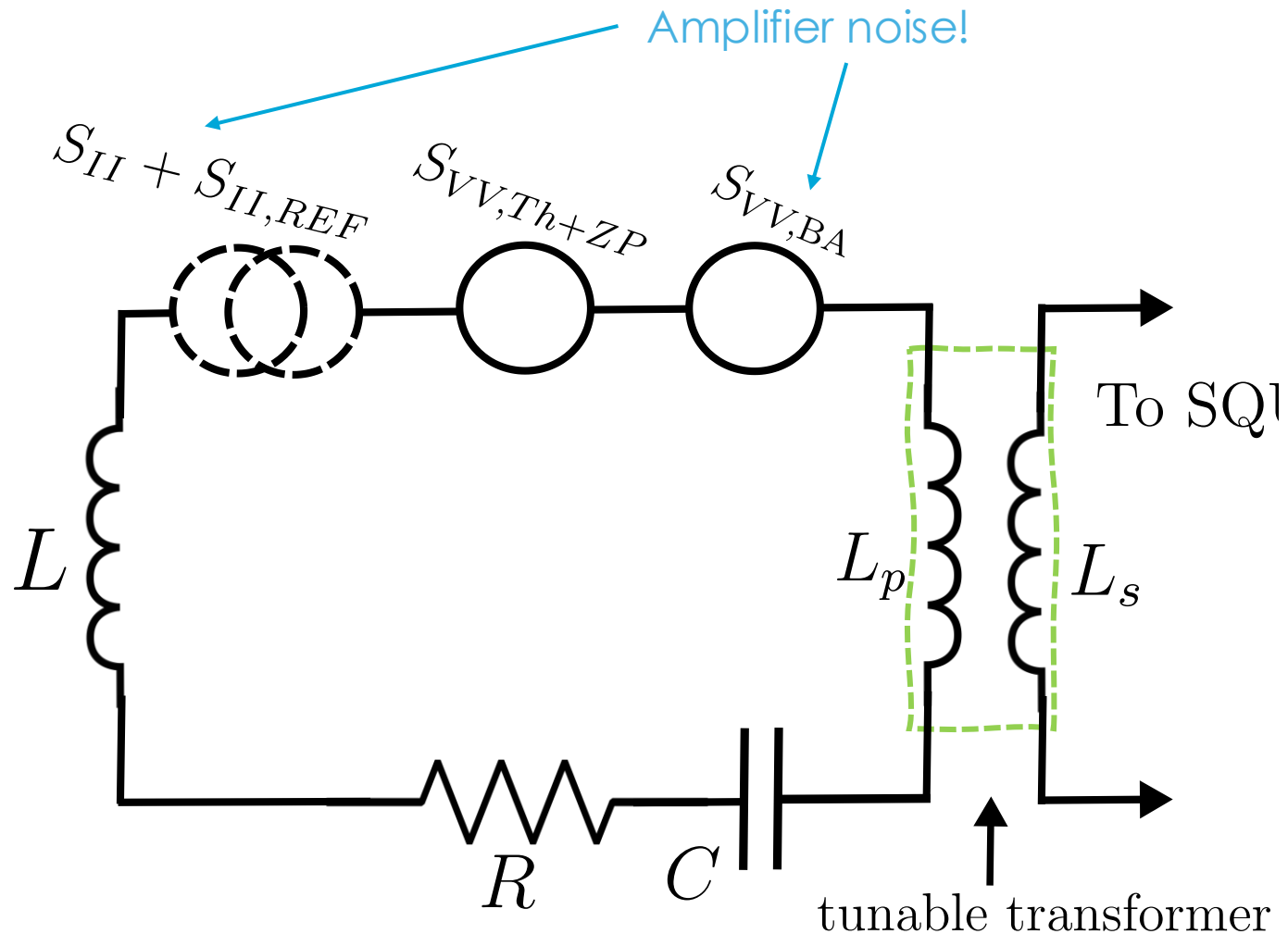

- The two noise sources are inversely proportional
- Relative strength dependent on how strongly the amplifier couples to the resonator

# 50L noise sources

Imprecision noise- white  
Backaction – resonator line shape

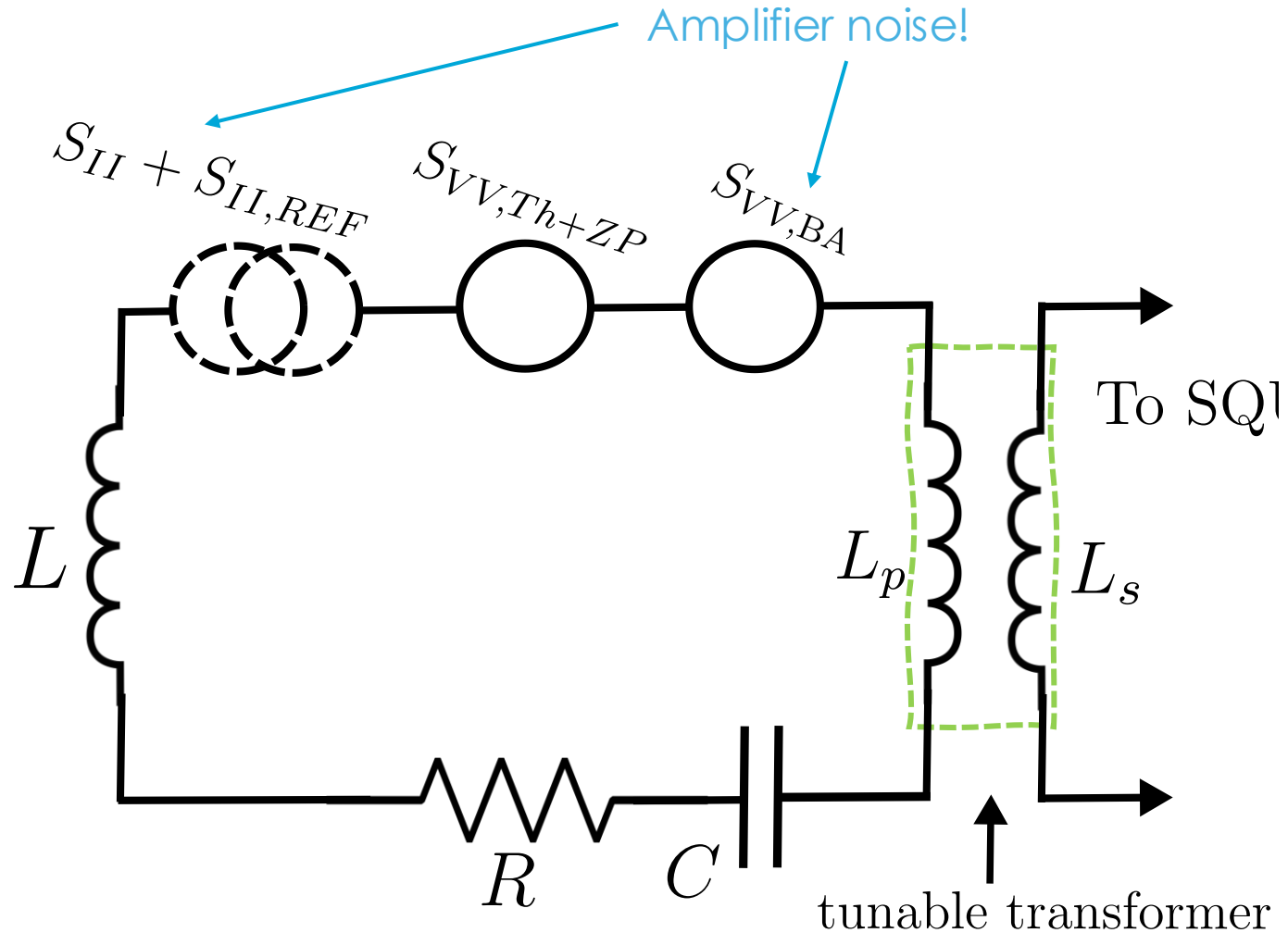

- The two noise sources are inversely proportional
- Relative strength dependent on how strongly the amplifier couples to the resonator

How do we apply this information to optimize our axion search?

# Optimizing scan rate Integrated sensitivity over a wide range of axion masses

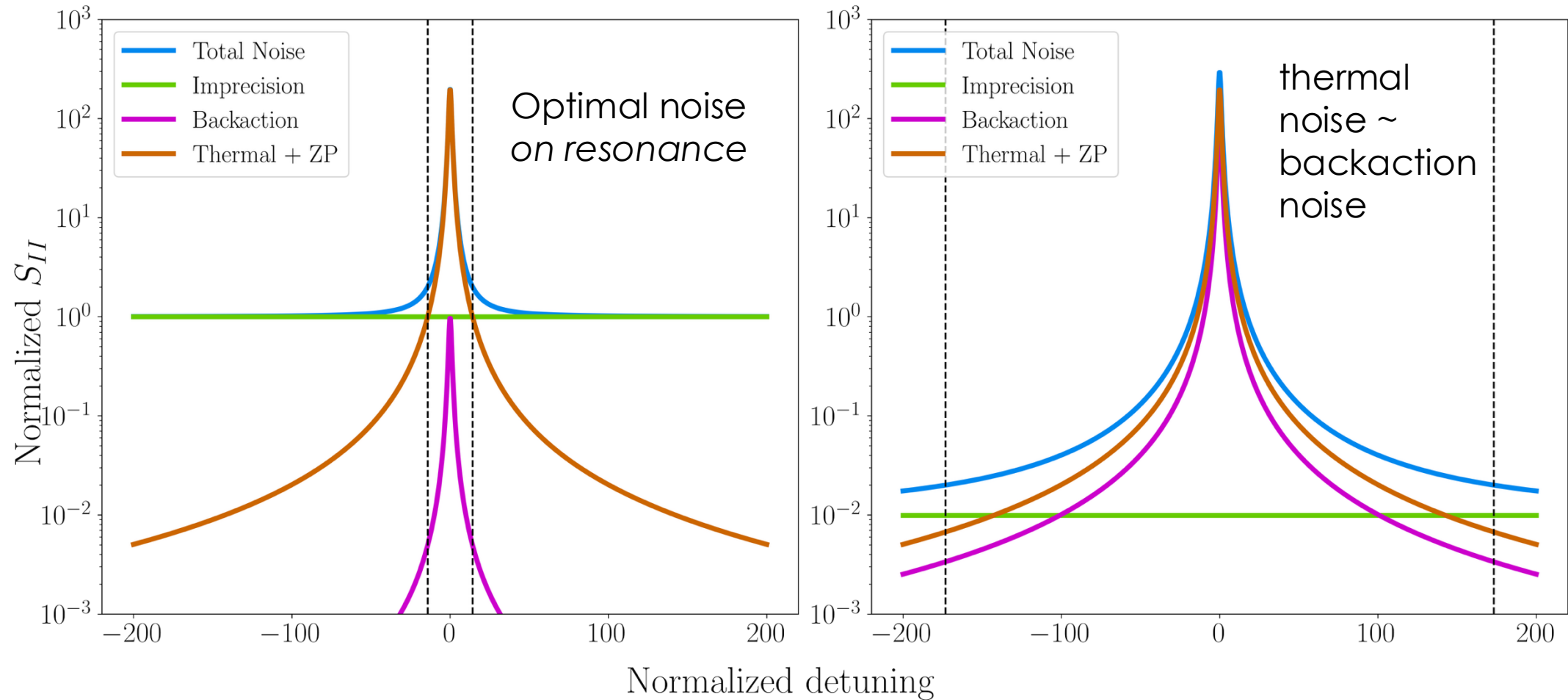

# Optimizing scan rate $\longrightarrow$ Integrated sensitivity over a wide range of axion masses

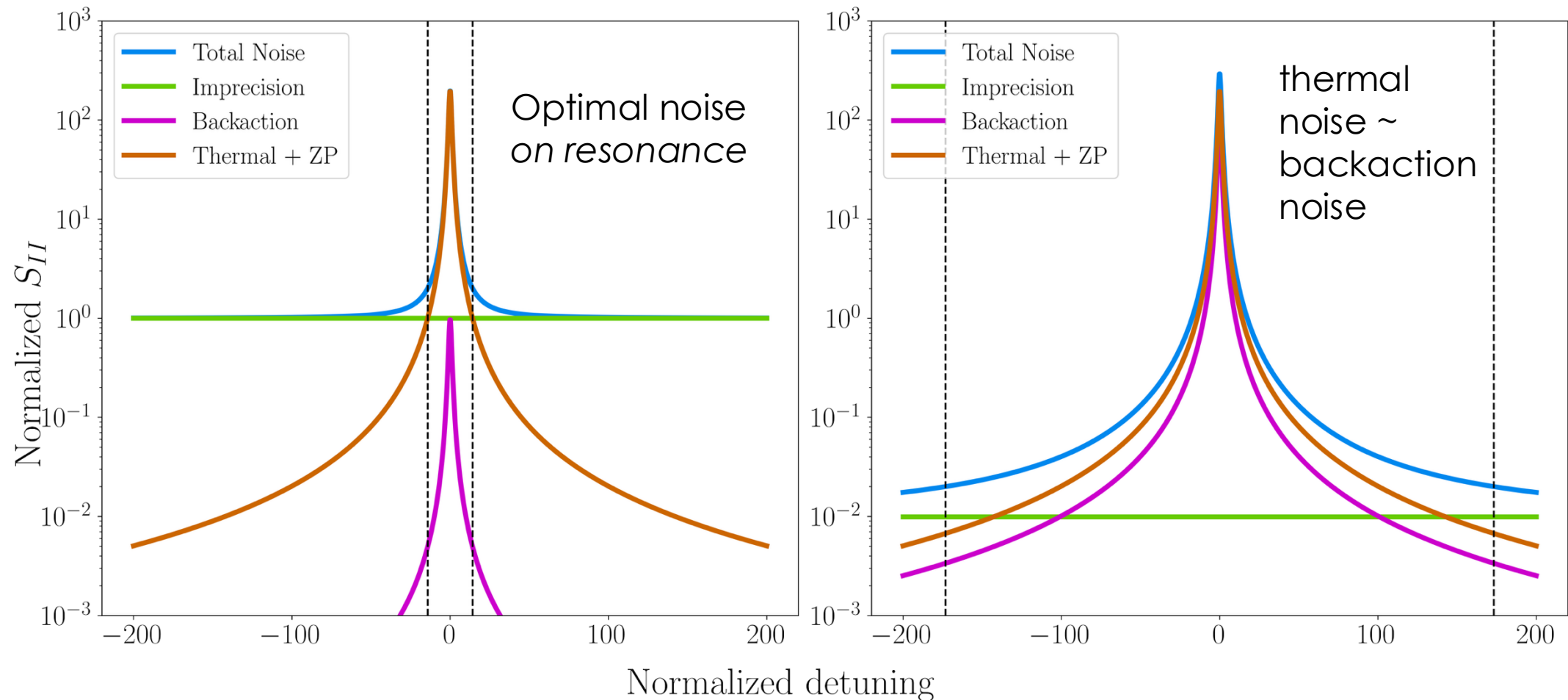

We obtain an optimal sensitivity bandwidth by tuning the transformer such that thermal noise  $\sim$  backaction noise

# How could we optimize in practice?

We want thermal noise  $\sim$  backaction noise

Use the resonator noise spectrum to distinguish thermal+ ZP + backaction noise from imprecision noise



We know how to model the thermal noise

# How could we optimize in practice?

We want thermal noise  $\sim$  backaction noise

Use the resonator noise spectrum to distinguish thermal+ ZP + backaction noise from imprecision noise



We know how to model the thermal noise

 In practice we will require very low coupling to the SQUIDs

 Want a design that will maximize our dynamic range

# Transformer Setup

# Current Snoopy Setup



Check  
concentricity  
of the rod  
within  
transformer

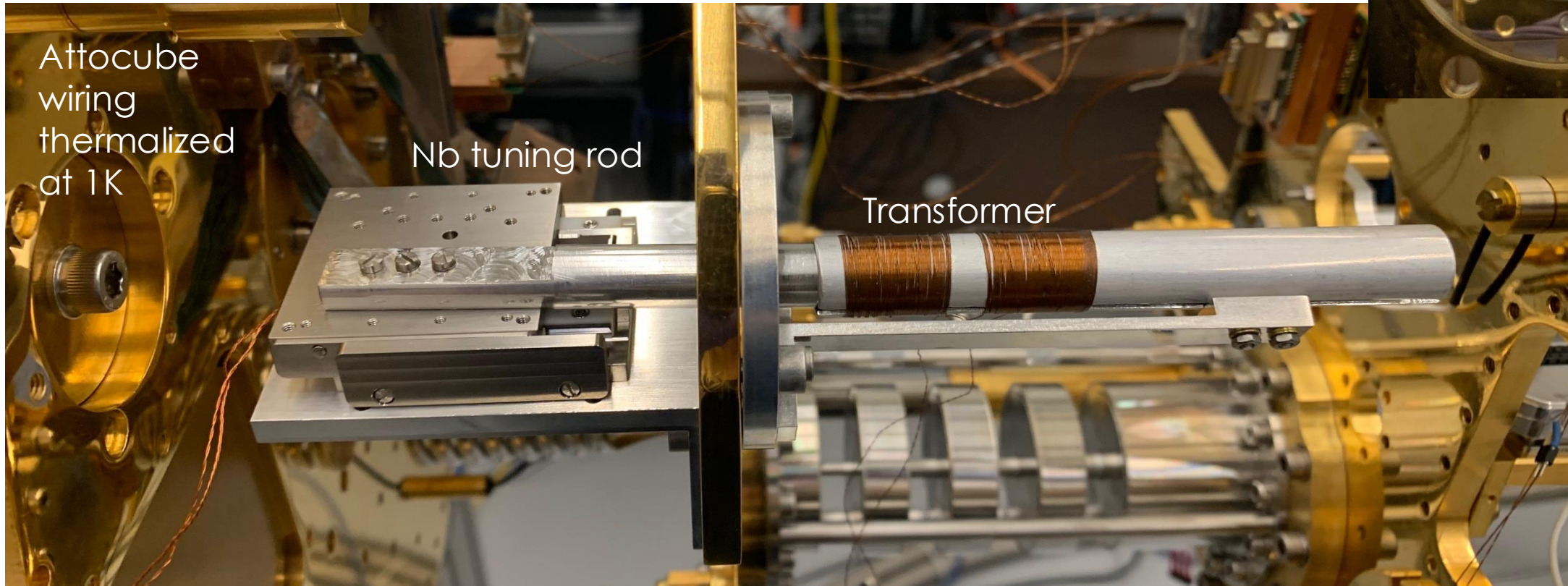
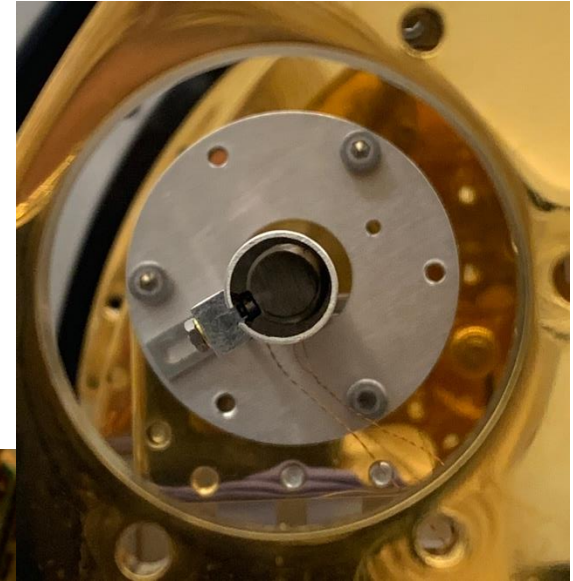

Thanks to Barkotel for designing initial winding scheme!

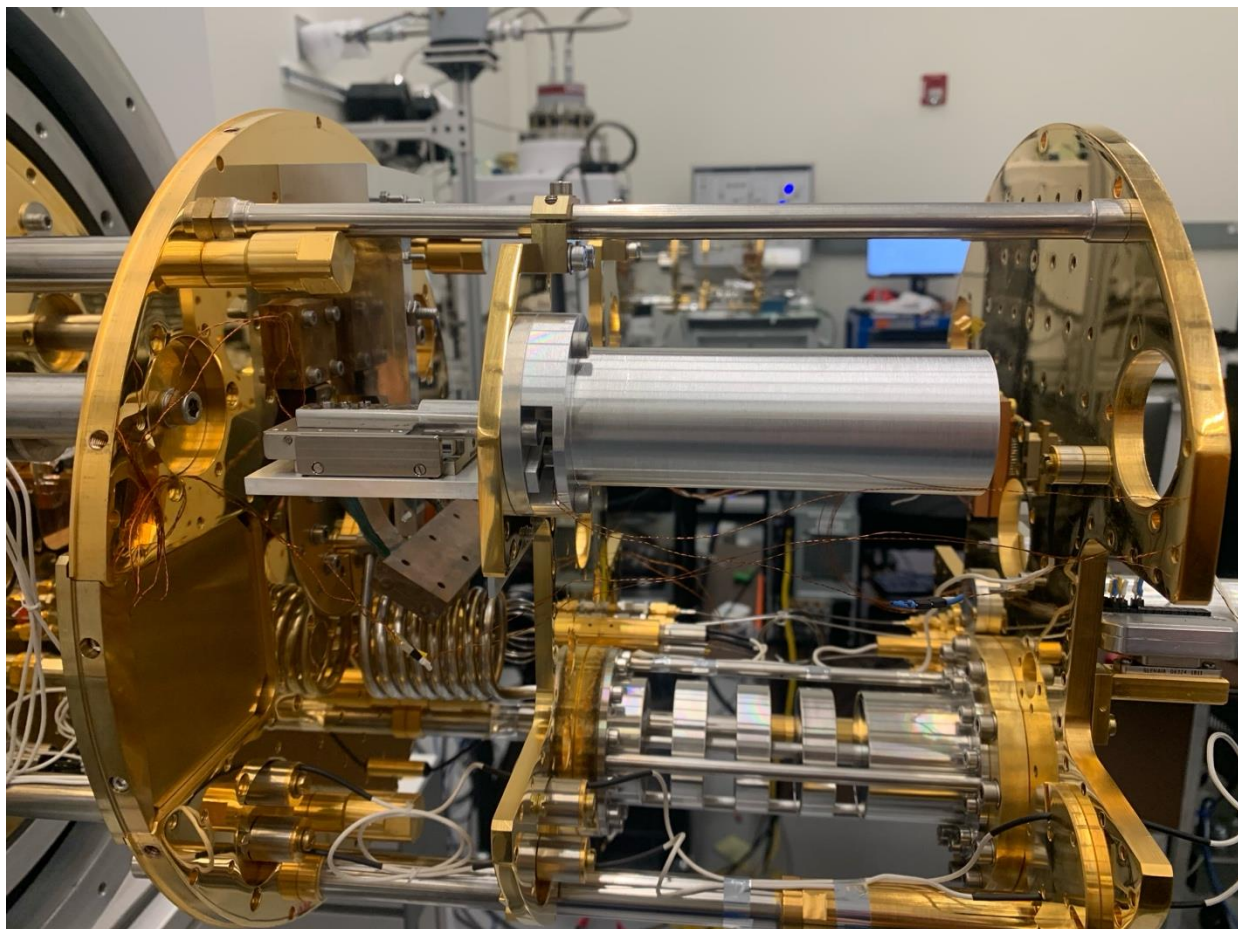

View of transformer setup with Al shield

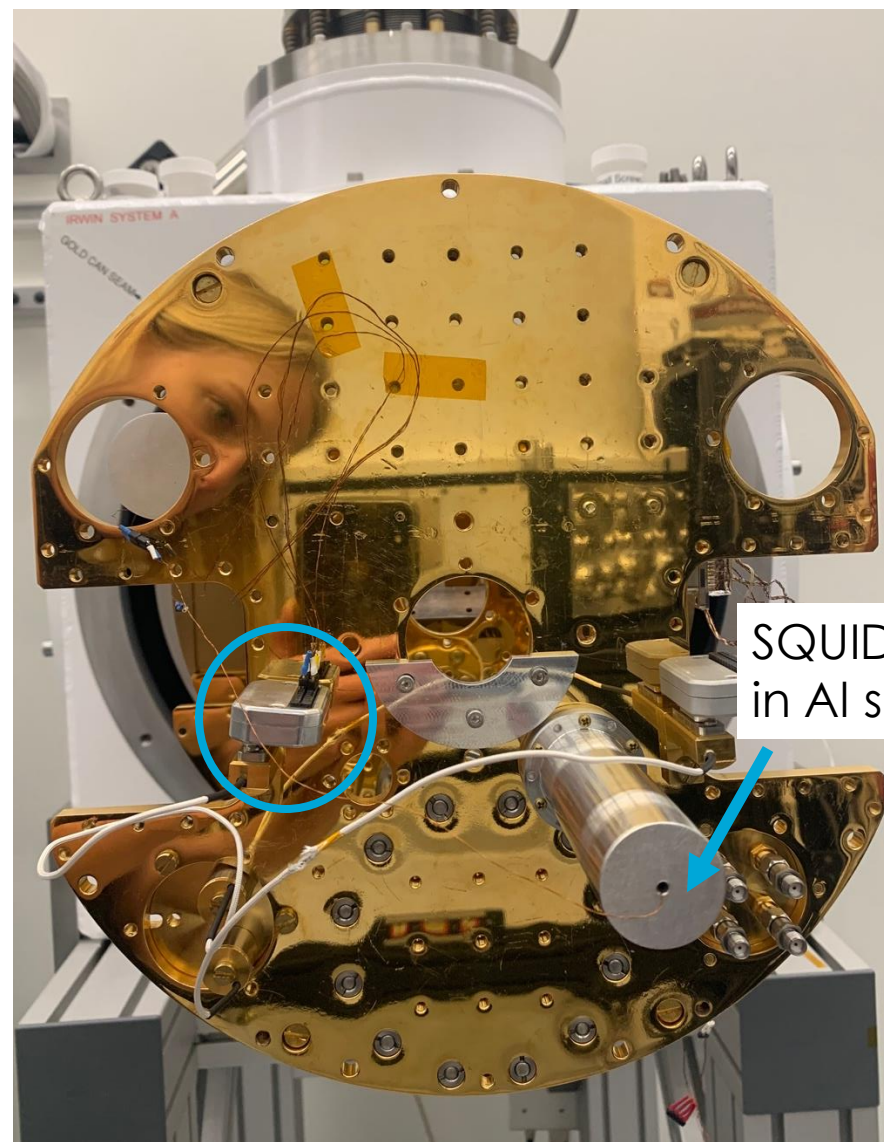

SQUIDs housed  
in Al shielding

No magnetic shielding around the  
SQUIDs

# Tuning Range

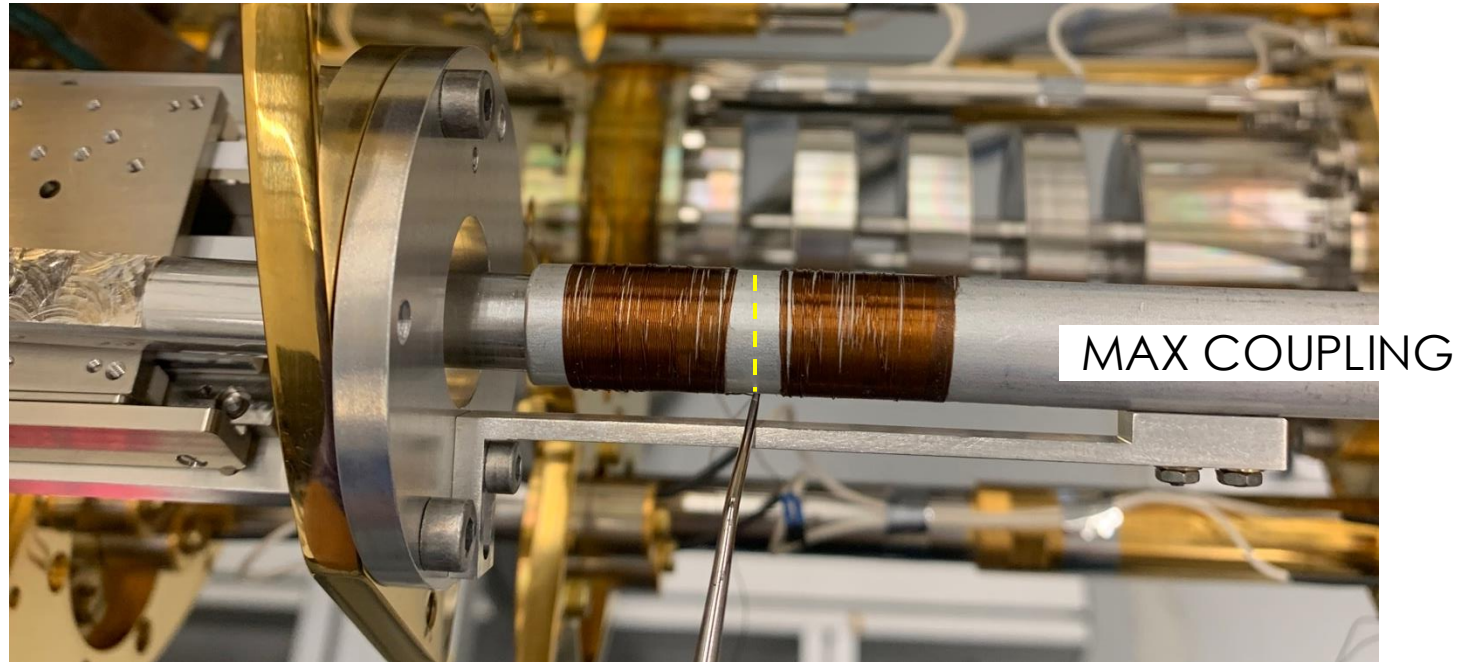

It would be nice to have the attocube throw span the entire transformer..

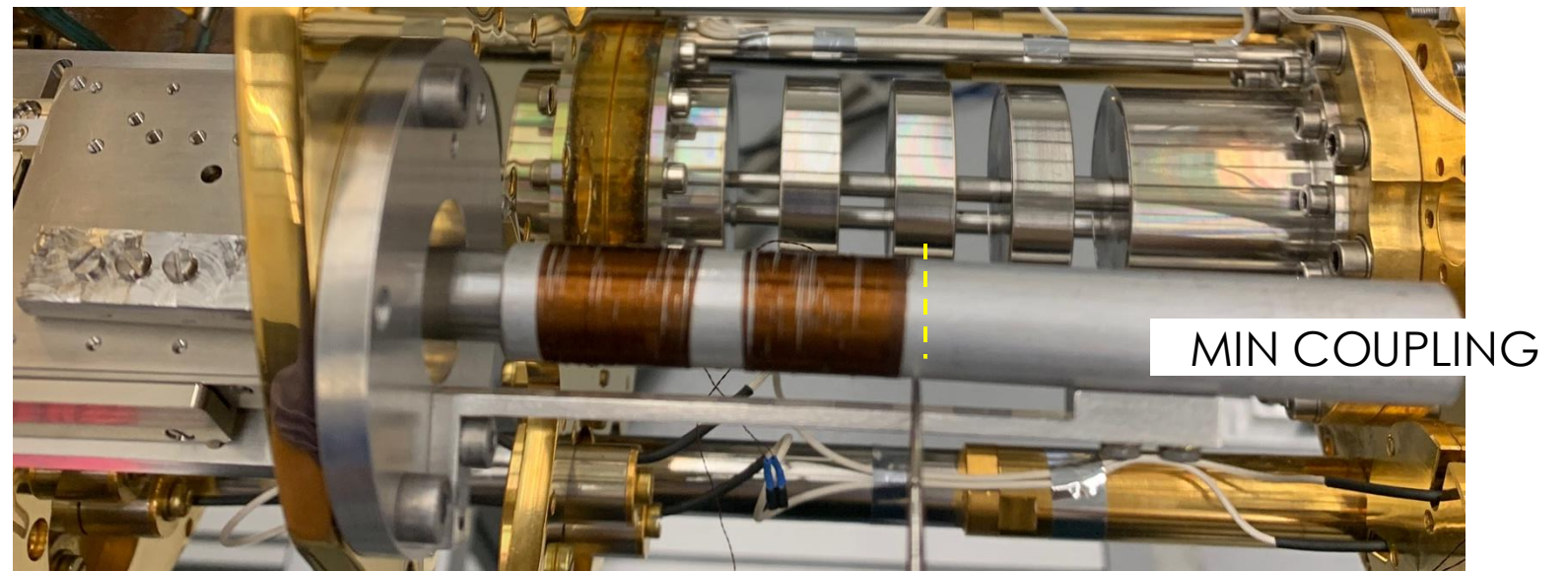

# What do we want to learn?

1. Can we see tuning as a function of rod position?
2. How close can we get to 0 coupling?
3. How much do we need to worry about thermalization?
4. How repeatable/ stable is a given coupling (rod position)?

# What do we want to learn?

1. Can we see tuning as a function of rod position?
2. How close can we get to 0 coupling?
3. How much do we need to worry about thermalization?
4. How repeatable/ stable is a given coupling (rod position)?

TBD! The SQUIDs had a ton of trapped flux this cooldown so we couldn't read anything out

# Filter Design

We want a bandpass filter between the secondary of the tunable transformer and the SQUIDs!

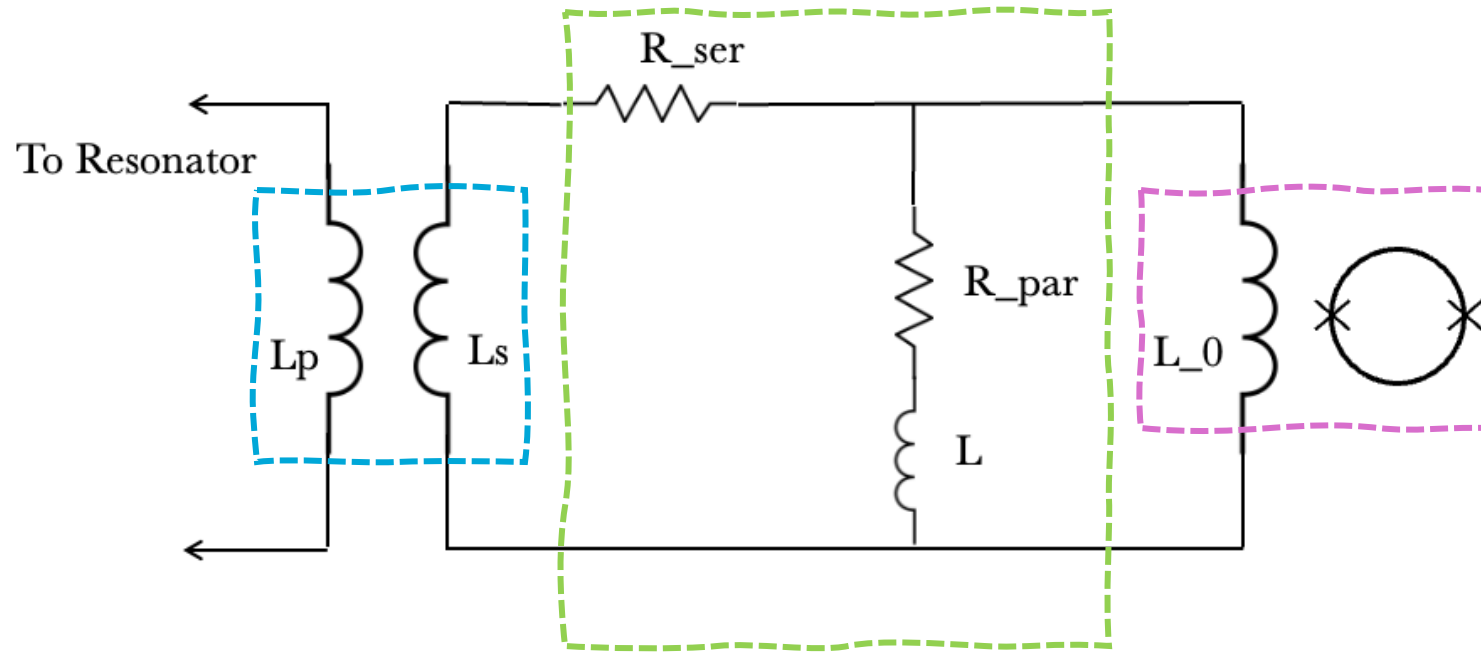

Block mechanical noise below 1KHz, and high frequency noise  $\geq 5$  MHz that can mix down into our search band

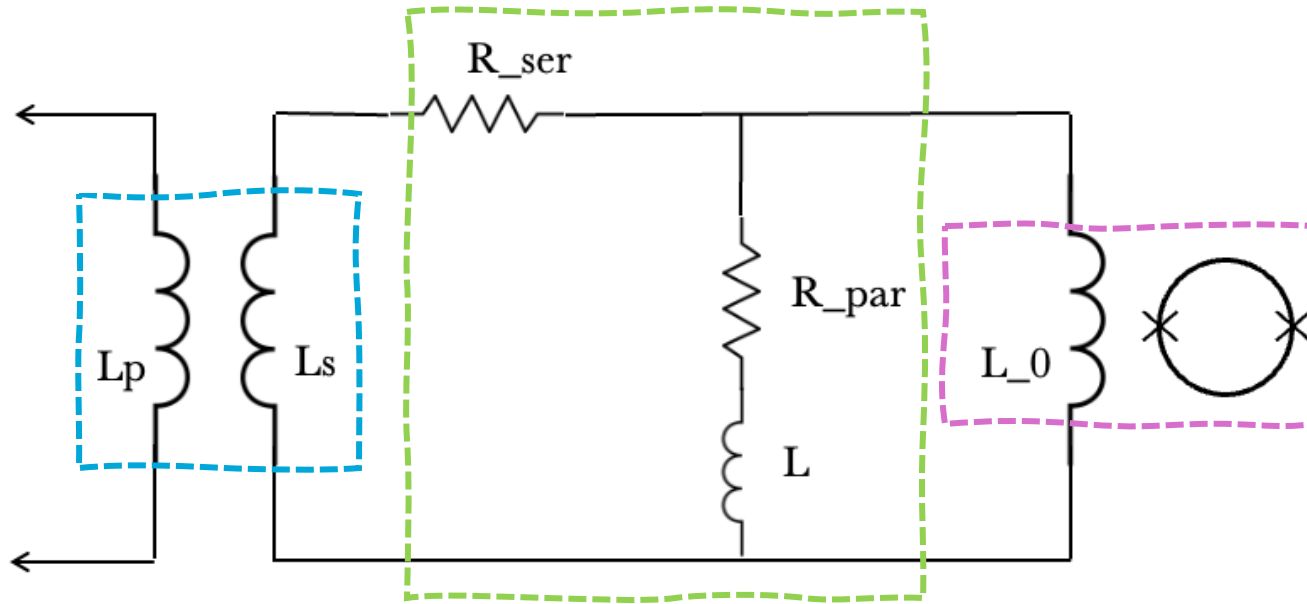

1. Transfer function of the filter
2. Johnson noise from added resistors
3. RMS variation in input  $\Phi$
4. Effect of the filter on resonator  $Q$

# Transfer Function

$$R_{ser} = 0.013\Omega$$

$$R_{par} = 10\Omega$$

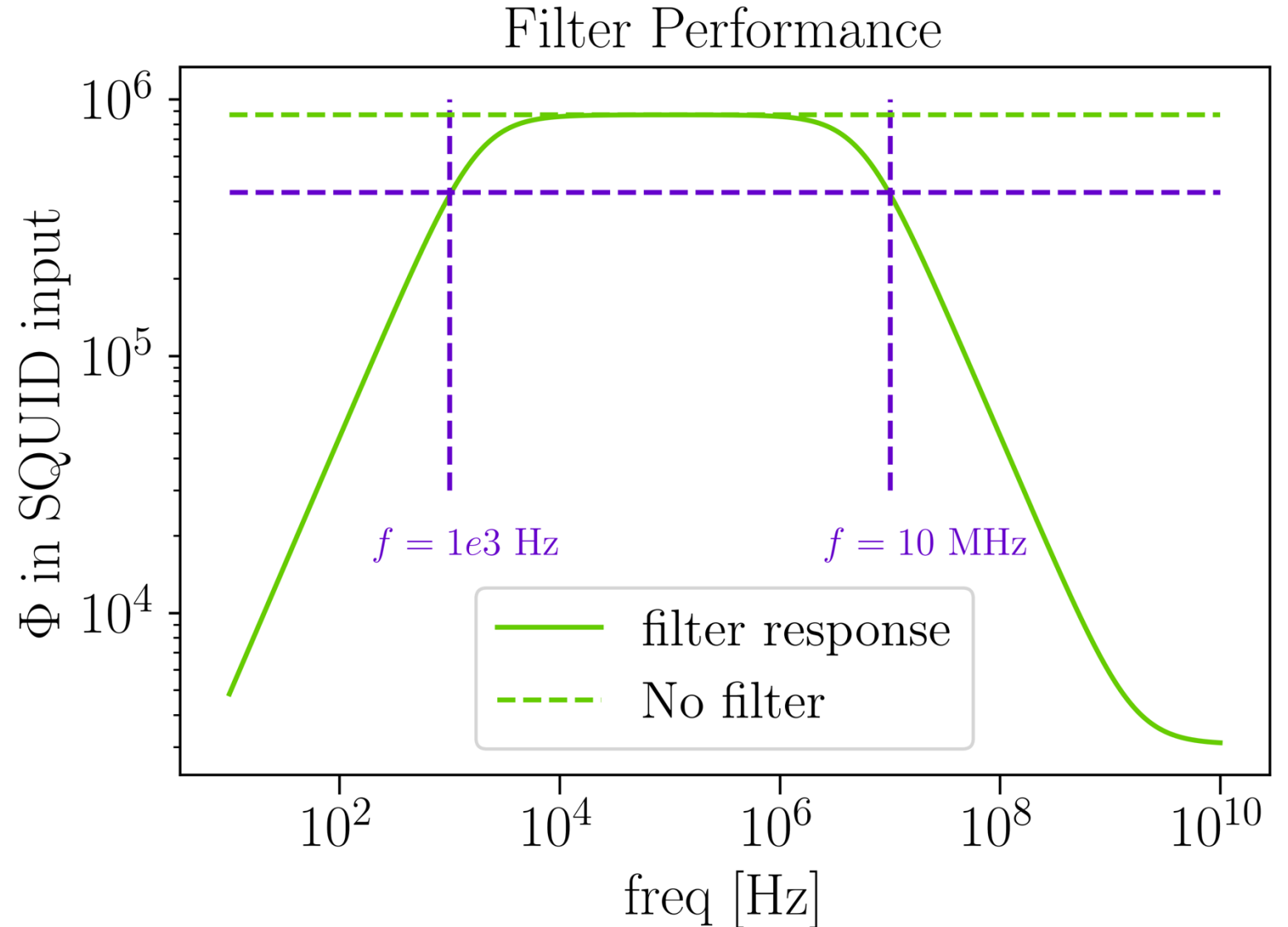

This whole process was iterative... need to consider all 4 filter requirements

# Johnson Noise in-band

$$S_{II,filter}(f) = \frac{4k_b T \text{Re}[Z(f)]}{|Z(f)|^2}$$



$$S_{\Phi\Phi,filter}(f) = M^2 S_{II,filter}(f)$$

$$0.5 \mu\Phi_0 / \sqrt{\text{Hz}}$$

Johnson noise should be > x2 lower than SQUID noise over our signal frequency range

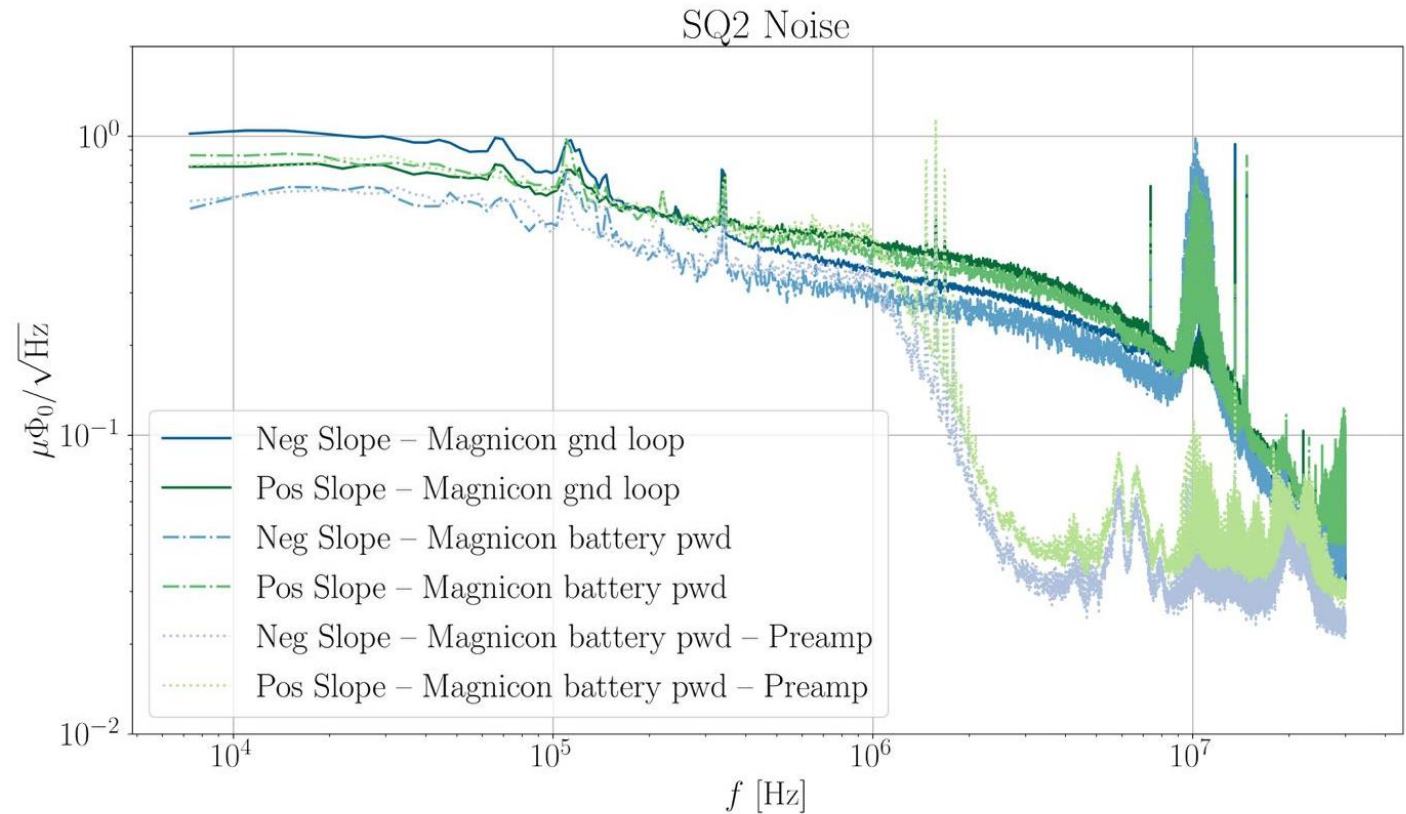

Used Nicholas' initial SQUID noise measurements above

# Johnson Noise in-band

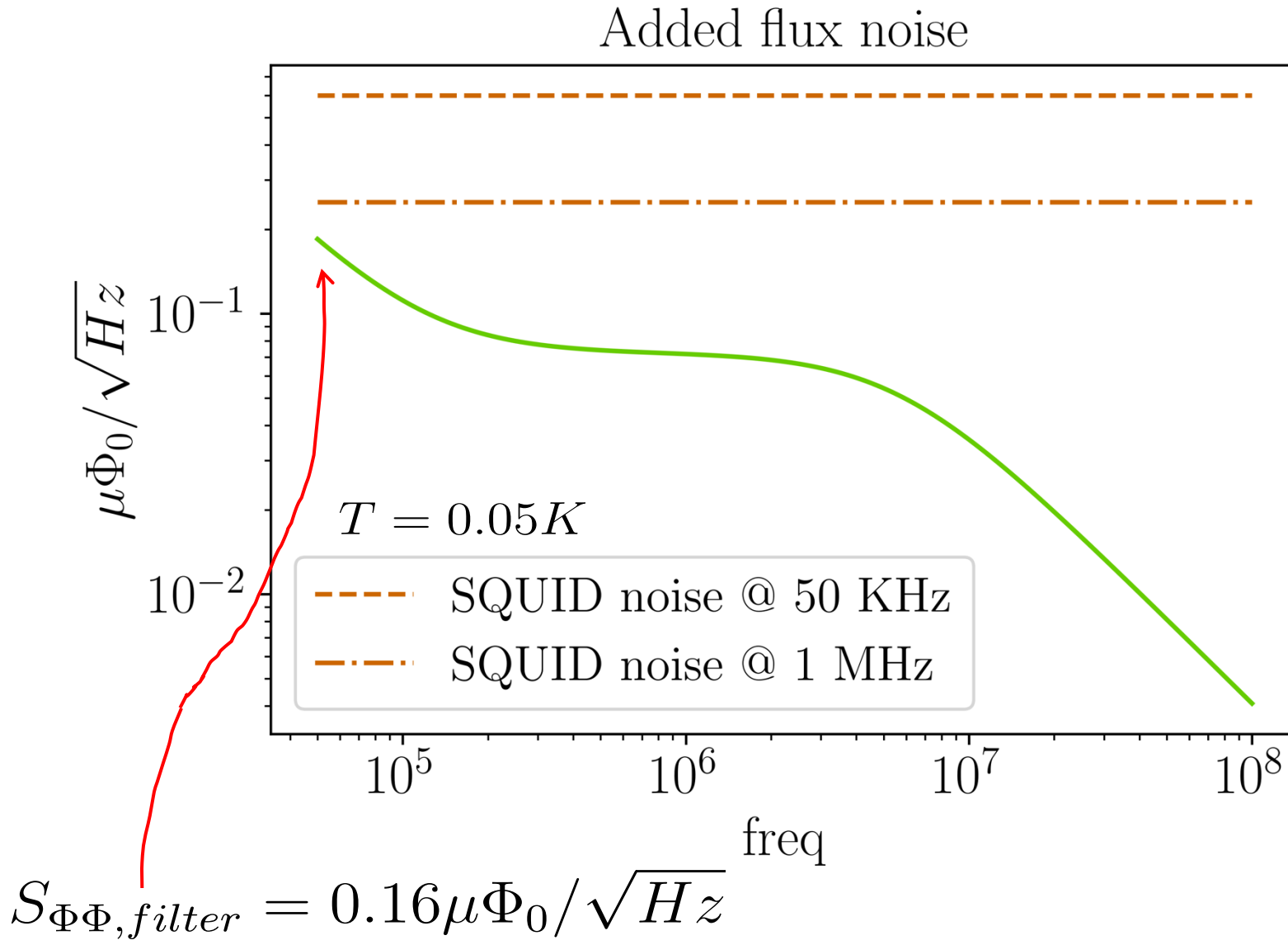

# Johnson Noise in-band

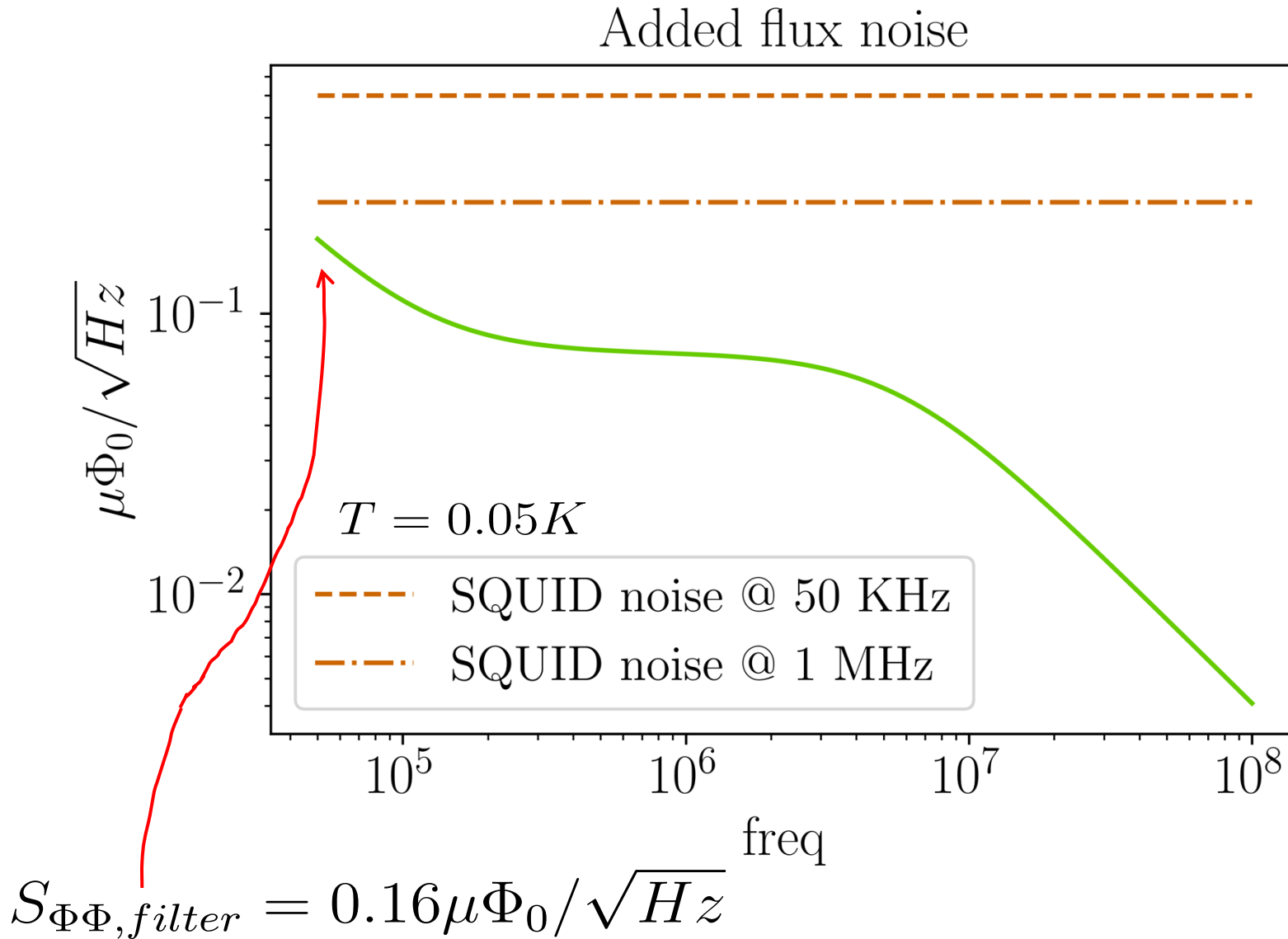

## RMS Variation in $\Phi$

-> Johnson noise out of band causes bias point fluctuations

$$\Phi_{rms} \approx 466 \mu\Phi_0$$

Small enough for us!

# Q Degradation

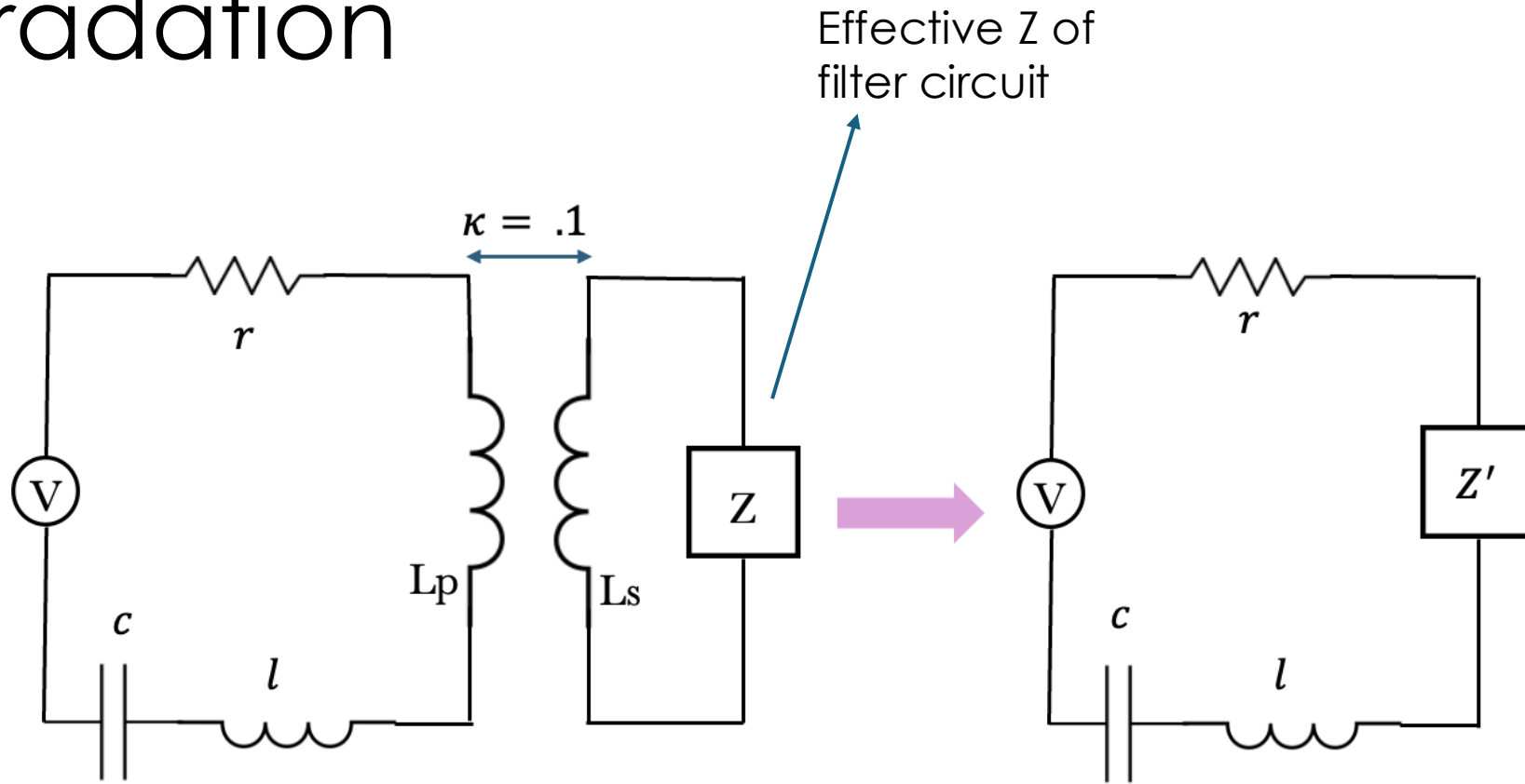

1. Get an effective series L, R, C
2. Compute new Q

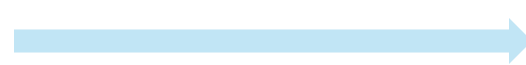

~ 6% degradation  
of  $Q = 1e6$

# Ok great! Let's build it

$$R_{ser} = 0.013\Omega$$
$$R_{par} = 10\Omega$$

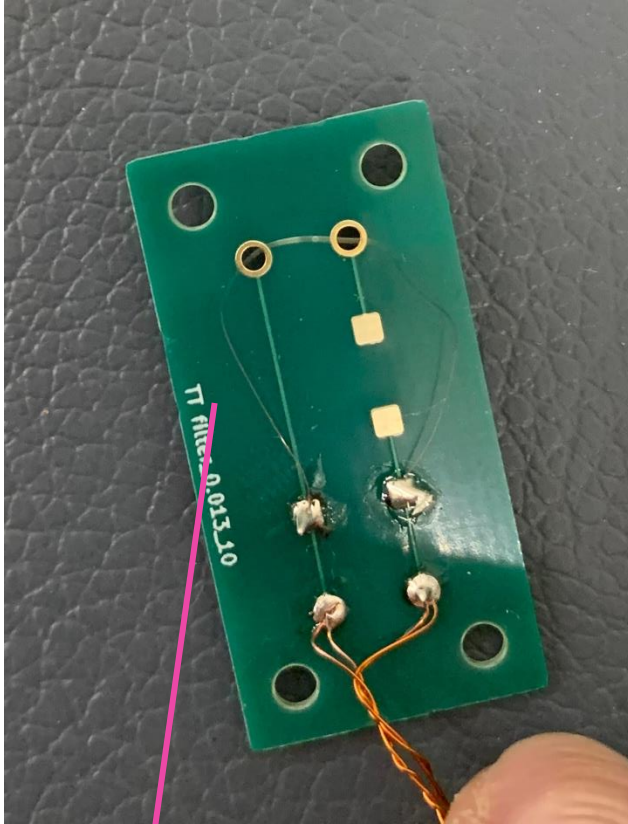

40 AWG Chromel wire

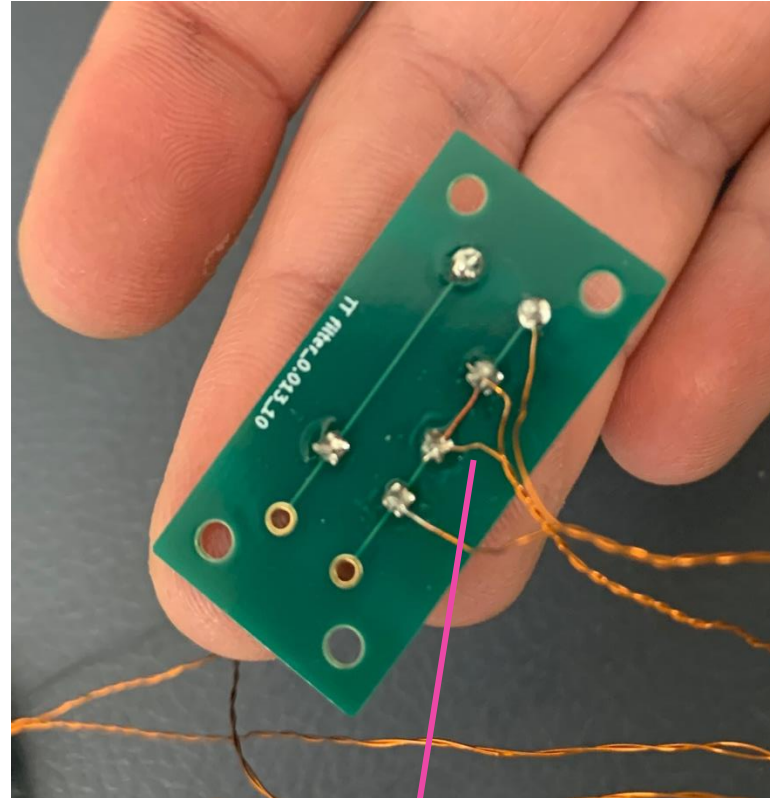

32 AWG Manganin

1. Test resistances at room temperature using 4 wire measurements
2. Characterize frequency dependence of resistance values



Integrate filter onto the SQUID chip

# Hutch Design Principles

1. Want as much magnetic shielding around the SQUIDs as possible- nested Nb & cryoperm tubes
2. Heated mount for the SQUIDs – want to be able to easily superheat them without disrupting entire system
3. Minimize wiring from transformer to SQUID input
4. Thermalized transformer!

Questions?