

Hunting for QCD Axion Dark Matter with the Princeton Axion Search

Saptarshi Chaudhuri

October 9, 2025

DMRadio Collaboration Meeting

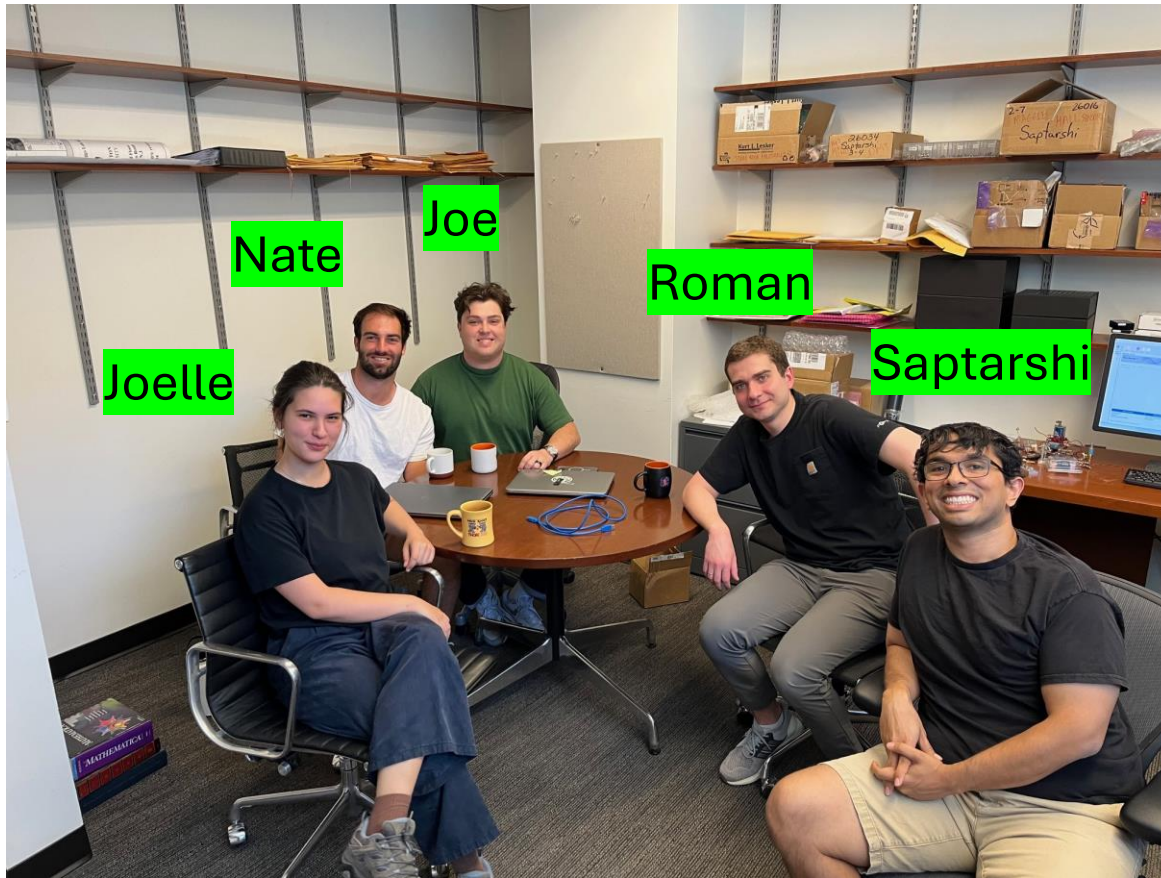

The PXS Team



Photo credit: Lyman Page (behind the camera!)

Princeton Axion Search (PXS) Team Members

Princeton: Joelle-Marie Begin, Saptarshi Chaudhuri, Roman Kolevatov, Nate Otto, Lyman Page, Joe Wiedemann (and soon Dicke Fellow Frank Fu)

DOE PPPL: Siwei Chen, Jon Dye, Yuhu Zhai, Lea Garren (PM)

Caltech/JPL: Peter Day, Farzad Faramarzi, Sasha Sypkens, Jonas Zmuidzinas

PXS: a 0.8-2.1 μeV QCD axion search

- Addressing critical transitional frequency range between DMRadio program and Sikivie-type cavity haloscopes

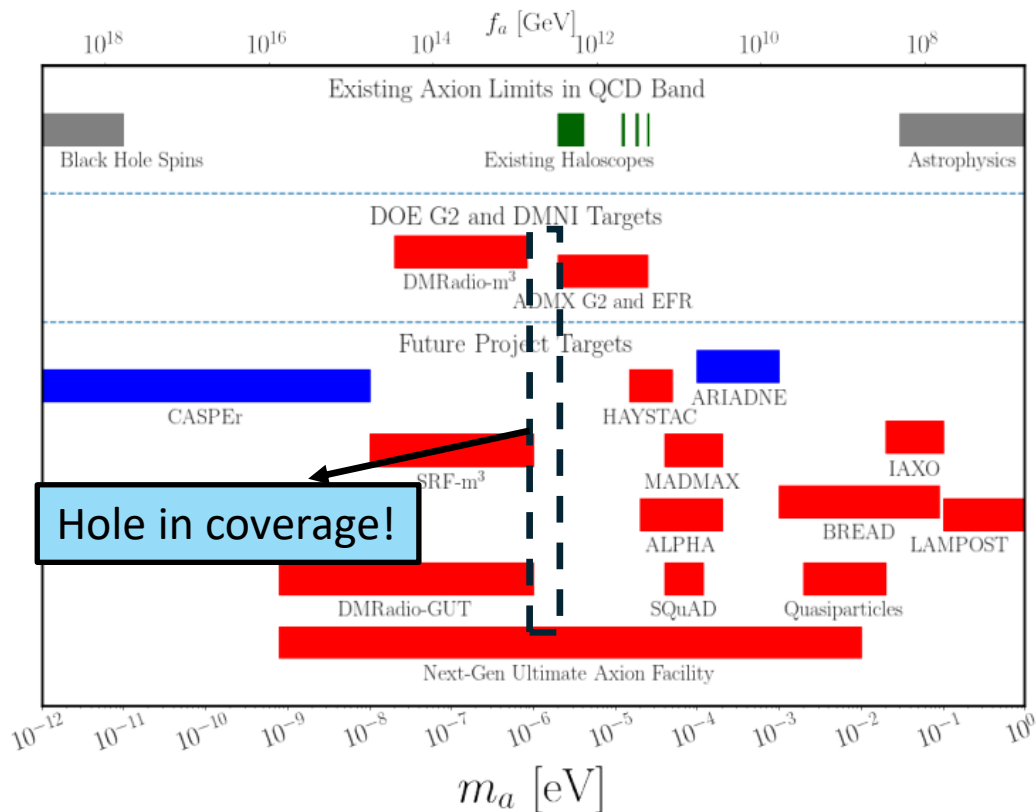

Snowmass 2021 White Paper on Axion Dark Matter, arxiv:2203.14923v3 (2023)

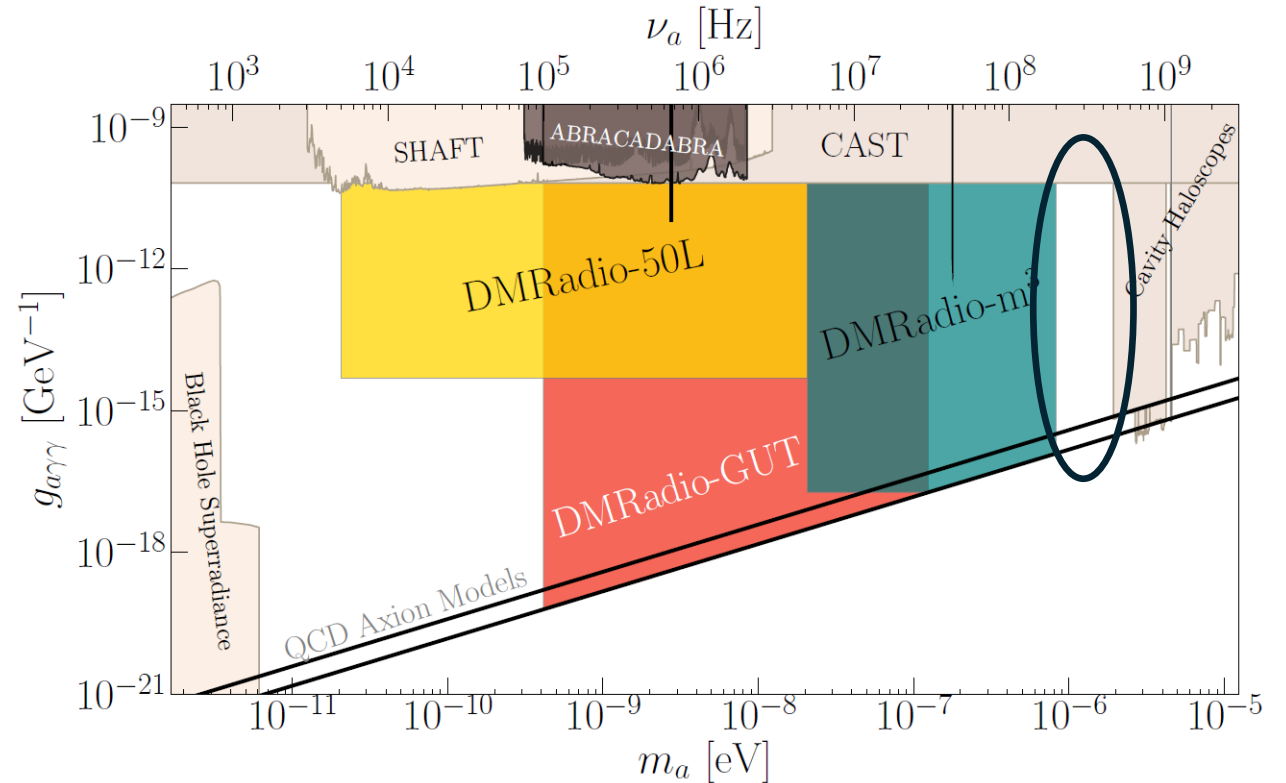

Brouwer, et al. (DMRadio collaboration) arxiv:2203.11246, PRD **106**, 112003 (2022)

Cavity Axion Searches

- Axion to photon conversion within an applied external magnetic field
- On resonance ($m_a = \text{cavity frequency}$) enhancement gives power excess at observed frequency
- Tune across mass range by changing internal geometry

PXS: Sikivie-type cavity haloscope, with “cavity-ish” lumped elements at the lower masses.

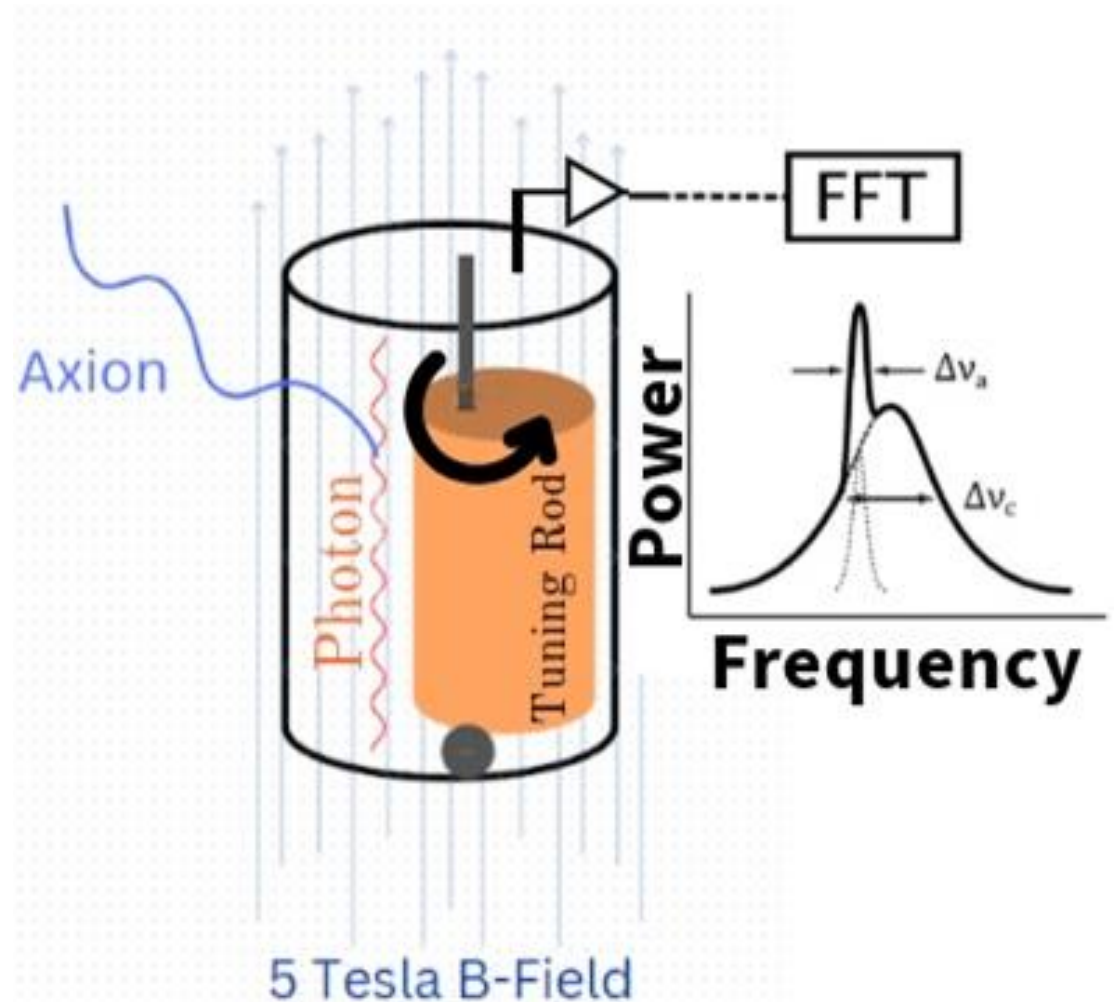

Magnet partnership with PPPL

- In collaboration with PPPL's High-Field Magnet Test Facility:
- Magnets using Nb₃Sn and HTS conductors
 - Charting the path toward higher field axion search magnets
- Pushing state of the art for cryogen-free, pulse-tube-cooled magnets



Ultra-powerful magnet facility launches at PPPL

By Raphael Rosen, Princeton Plasma Physics Laboratory on Feb. 7, 2024, 1:14 p.m.



7.5 T, 30 cm bore conduction-cooled magnet for HTS tape inspection- commissioned last April

New axion search magnet

PXS magnet target
parameters: 5 Tesla, 78.7 cm
diameter, 101.6 cm height

- Coil to be cooled to 4K with multiple cryocoolers
- Magnet design ongoing
- 5T Nb₃Sn model coil at ~25% length scale for validations

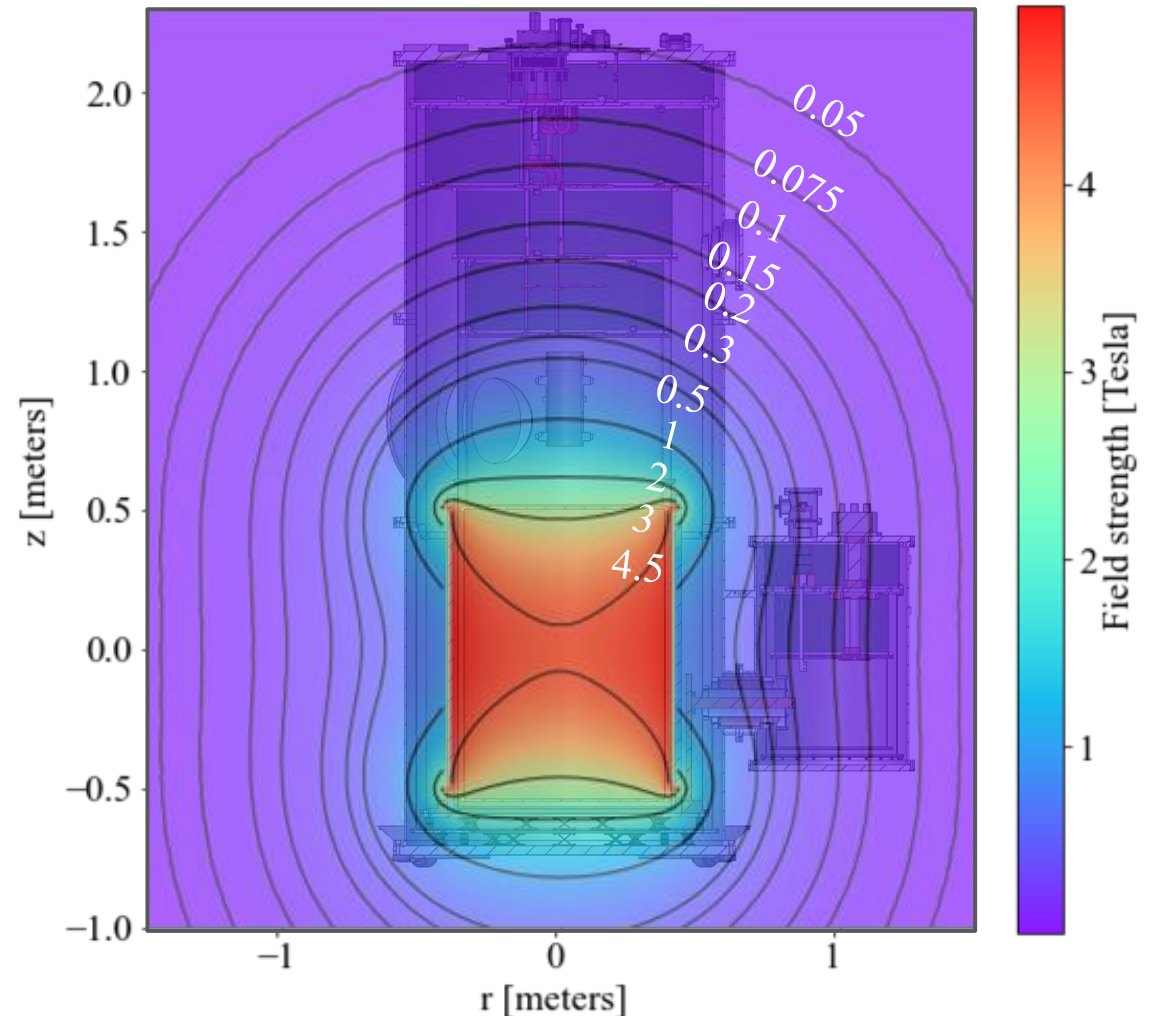

Magnetic field profile overlaid with cryostat design

Test cryostat

Pulse tube

40K stage

4K stage

Current leads

Magnet volume

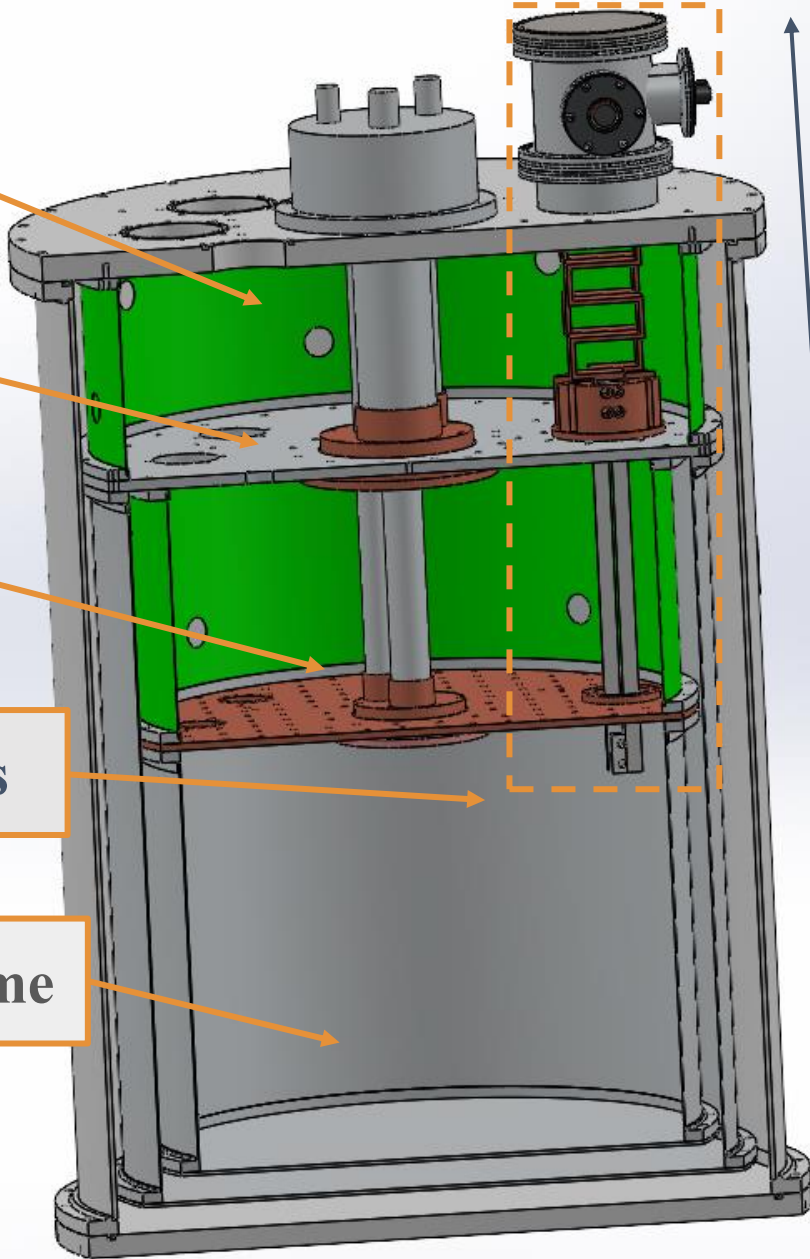

~1 m



Joelle working on cryostat

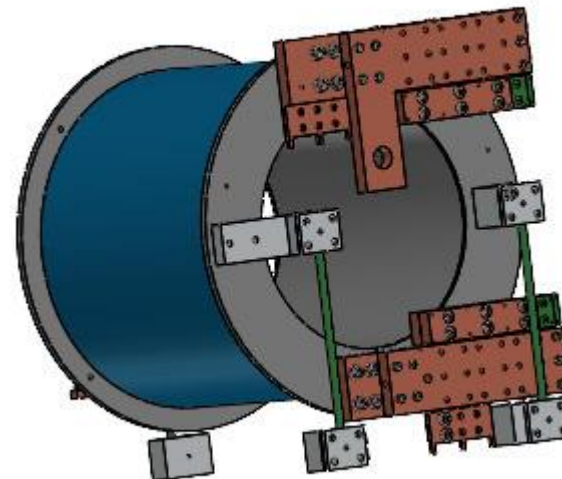

Model coil CAD

Demonstrated 600A to 4K! Sufficient for magnet operations

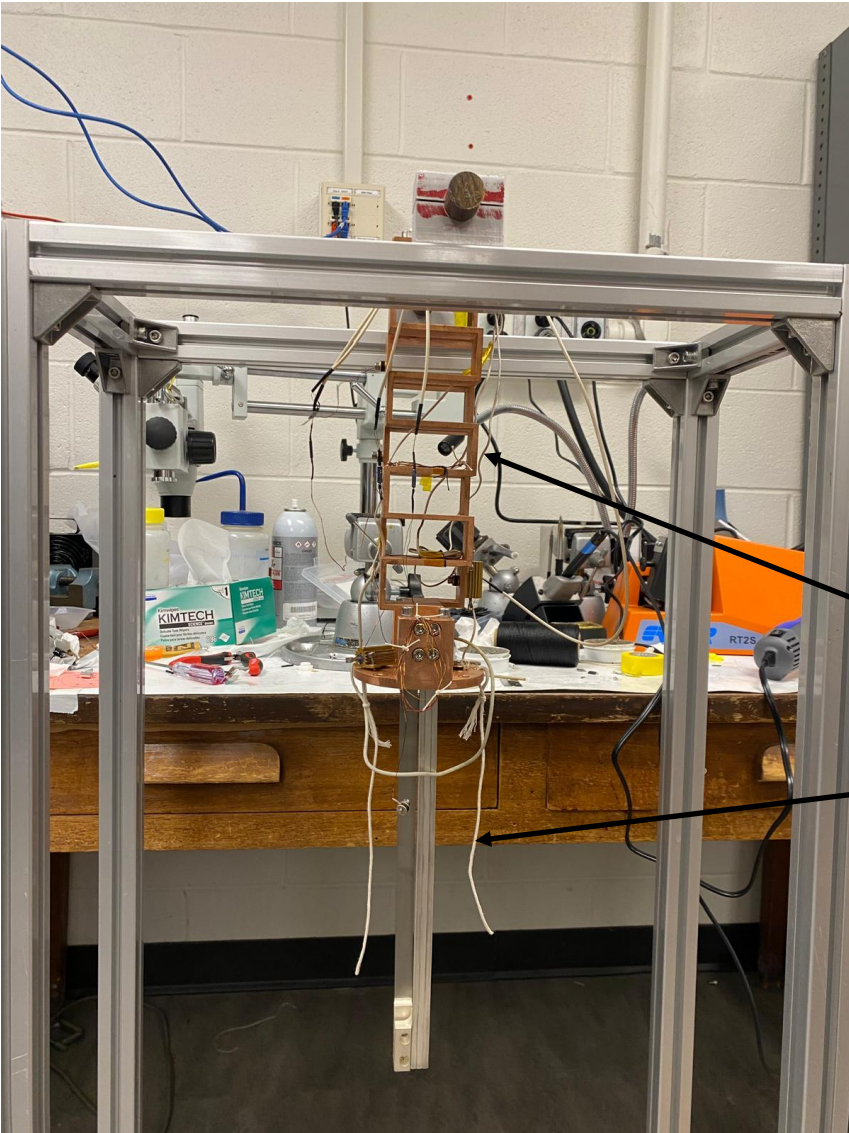

Copper leads (300K-40K)

BSCCO HTS leads (40K-4K)

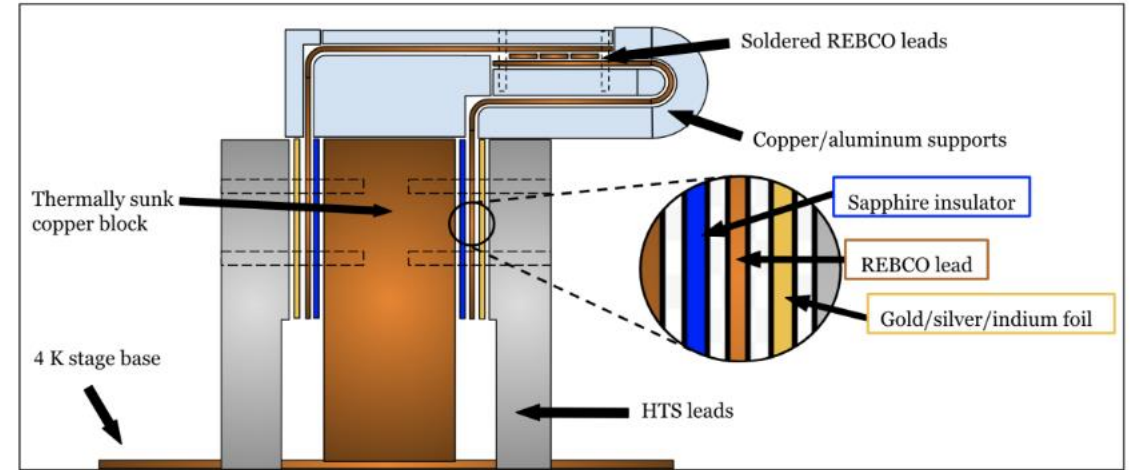

REBCO shorting assembly at 4K, diagram by Will Roberts (JP)

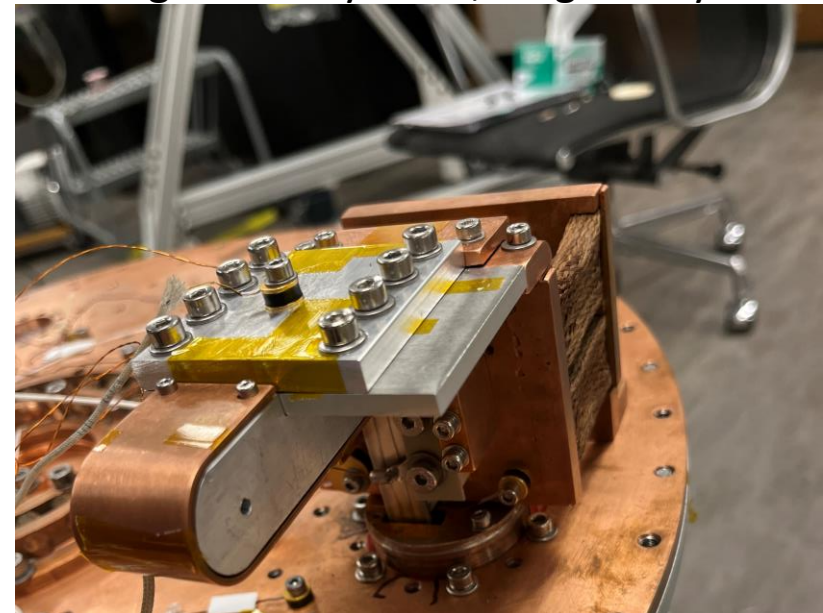

Model coil

- 20cm bore, 25cm height coil using ~4.5 km of ITER-type Nb₃Sn
- Operating current: ~200A - > 5 Tesla field
- Test cooldown with mandrel over the summer

Copper shorting bar

Copper-encased REBCO highway

4K side of BSCCO HTS leads

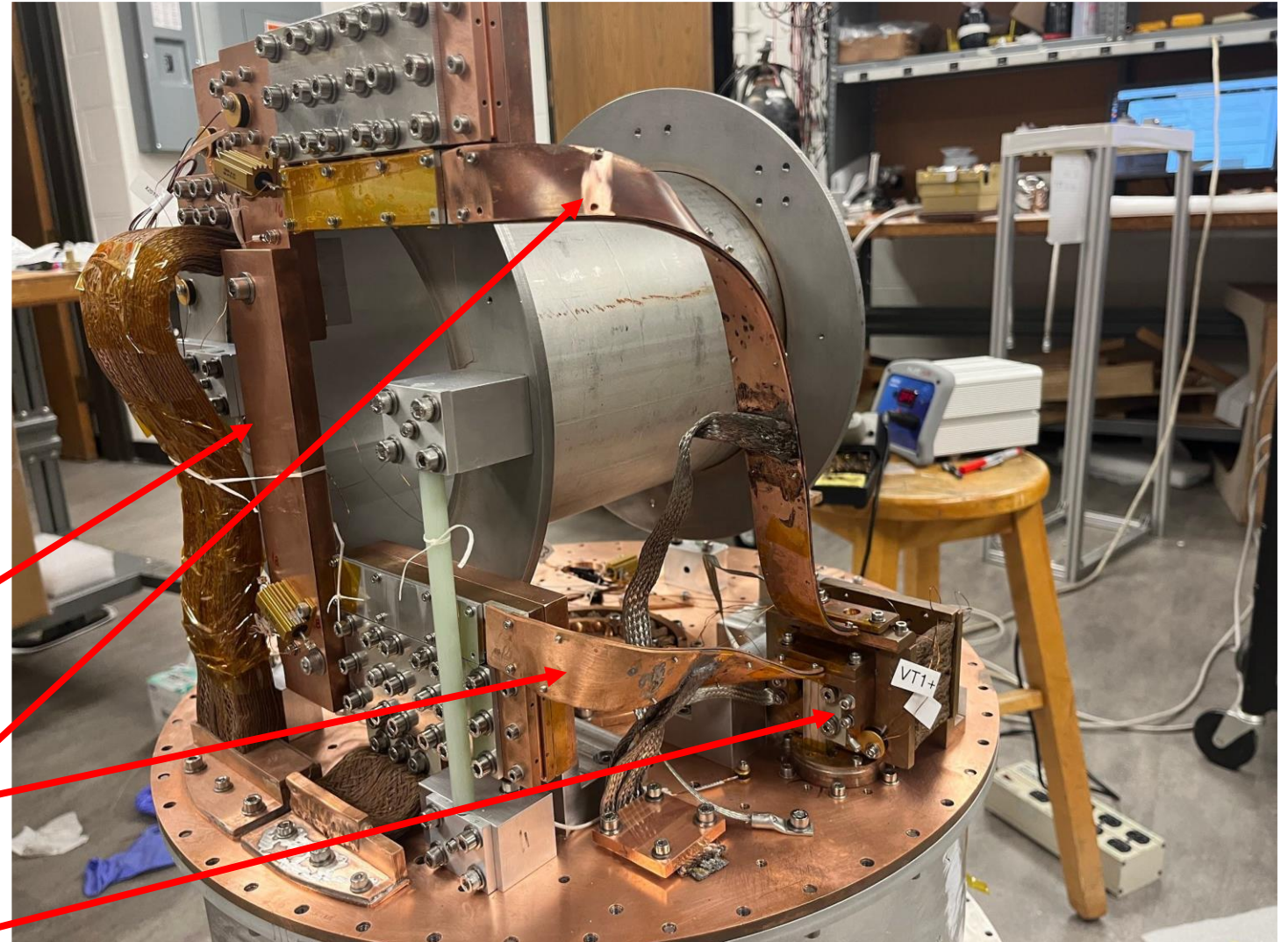

Temperatures still below 4K up to 550 Amps

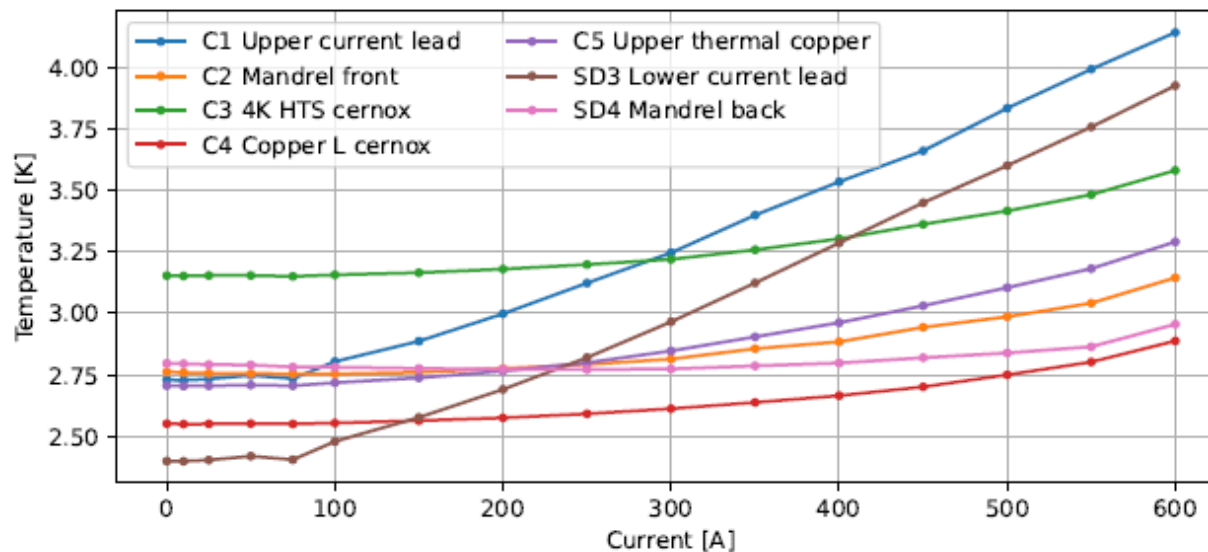
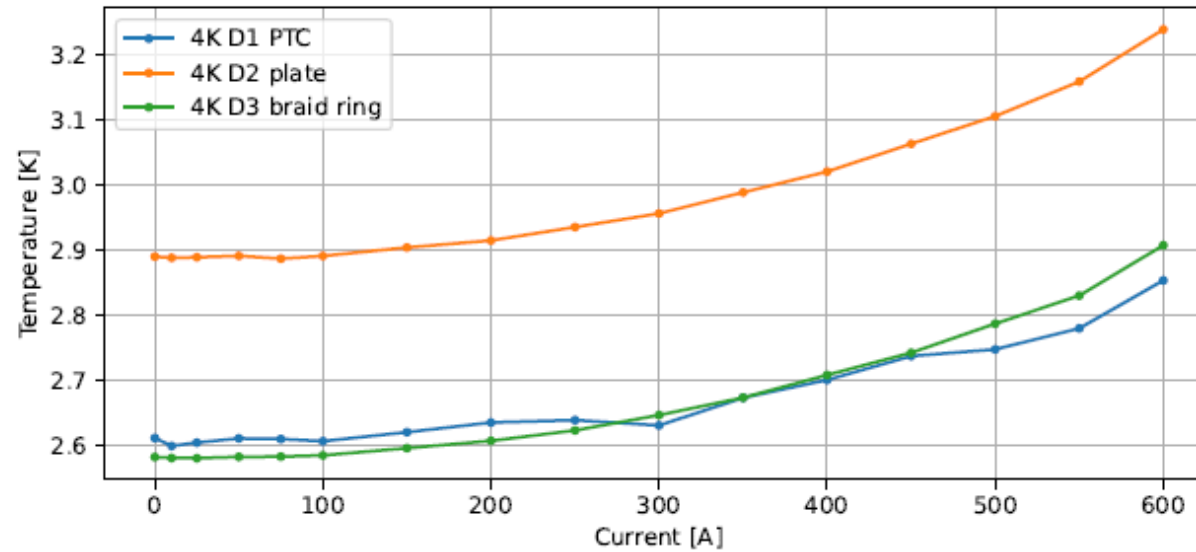

Model coil next steps

- Wire has returned from S-glass braiding (Bruker)
- Winding, heat treatment, VPI at PPPL
- To be delivered to campus mid-November



Linear winder



Tanks for VPI

More photos!



Furnace for heat treatment

Schedule for full-scale PXS coil

- Critical design review for full-scale PXS coil, Oct. 21
 - Dry runs tomorrow and next Tuesday
 - Chaired by Steve Gourlay
 - External reviewers from FNAL, LBNL, expertise on pulse-tube cooled magnets
 - After review, press “go” on conductor purchase
- Manufacturing readiness review scheduled for January
 - Facility downselect for winding, epoxy impregnation
- Coil delivered to Princeton campus end of 2026

Full-scale cryostat+DR on order. Early 2026 delivery.

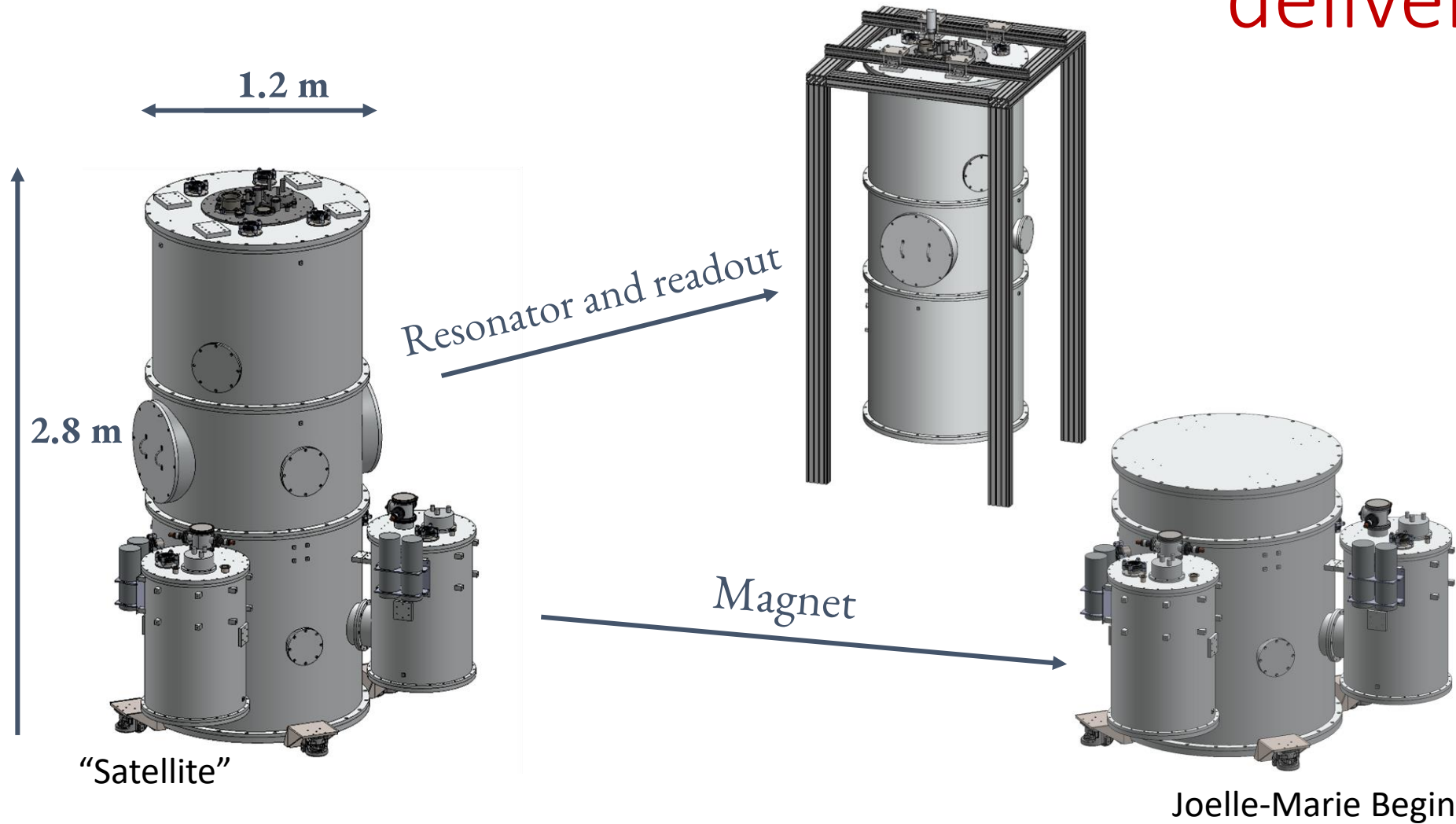

Microwave cavity

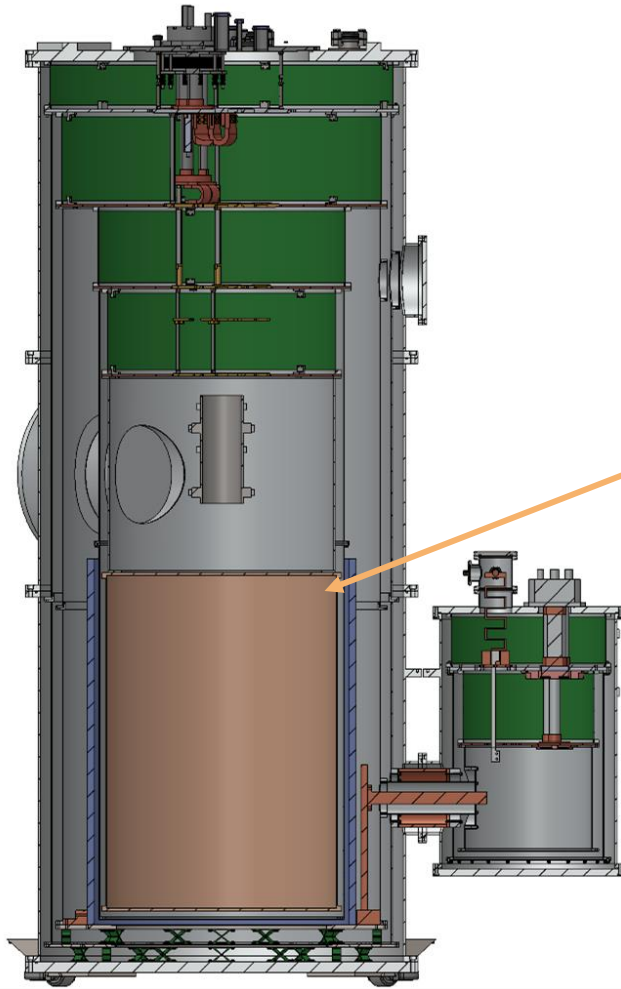

Nate Otto

Full scale prototype built. Al1100 with Al 6061 endcaps. Science cavity will be copper-plated.

First configuration: 380-500 MHz; Second + third config: 200-380 MHz

Characterization of empty cavity

- TM010 frequency of 327.7 MHz measured, with Q of 48k
- *Welding and endcap seams do not significantly degrade Q.*
- Analyzed backgrounds, temperature variation
- Informed bead pulls

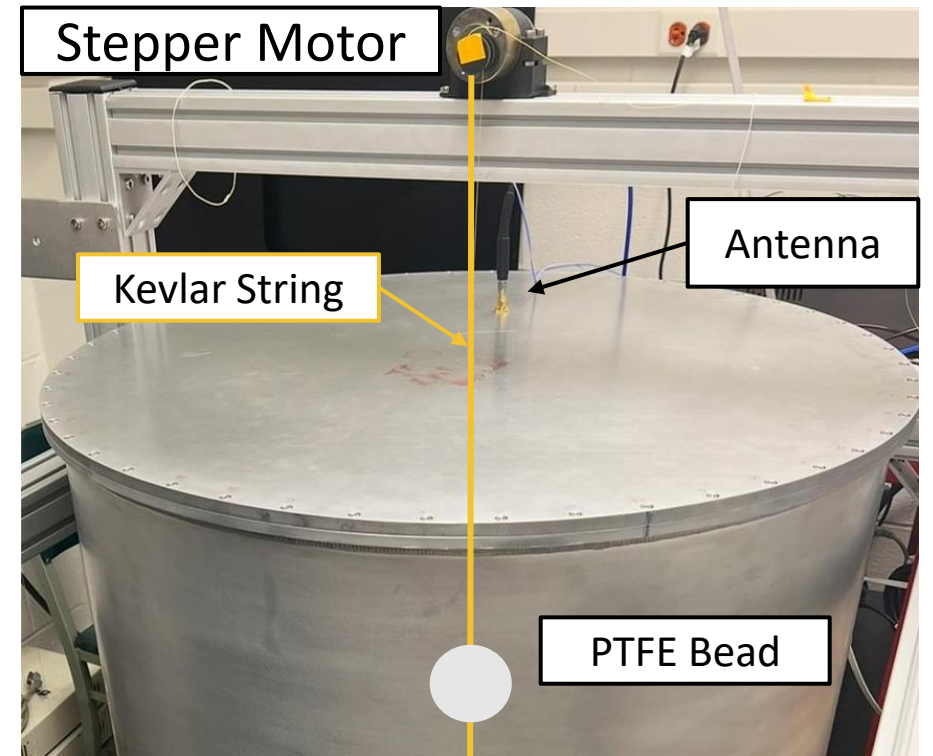
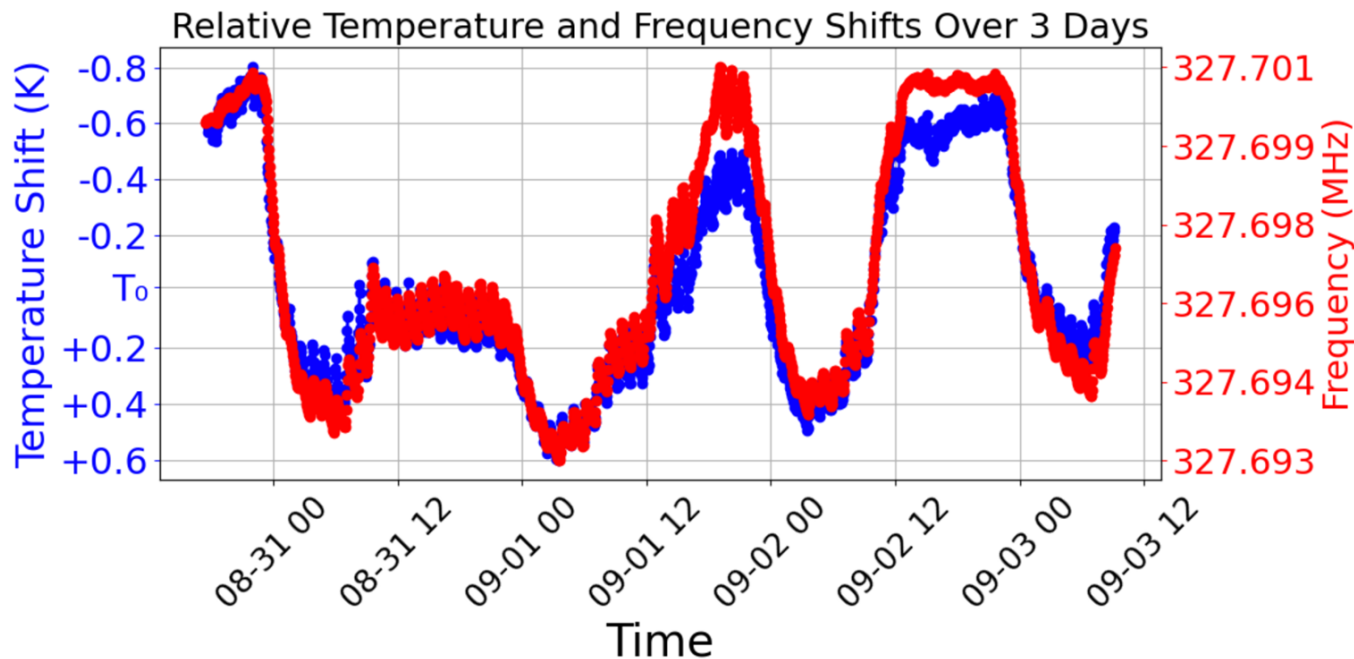

Bead pulls match theory well

- 6.35 cm diameter PTFE bead

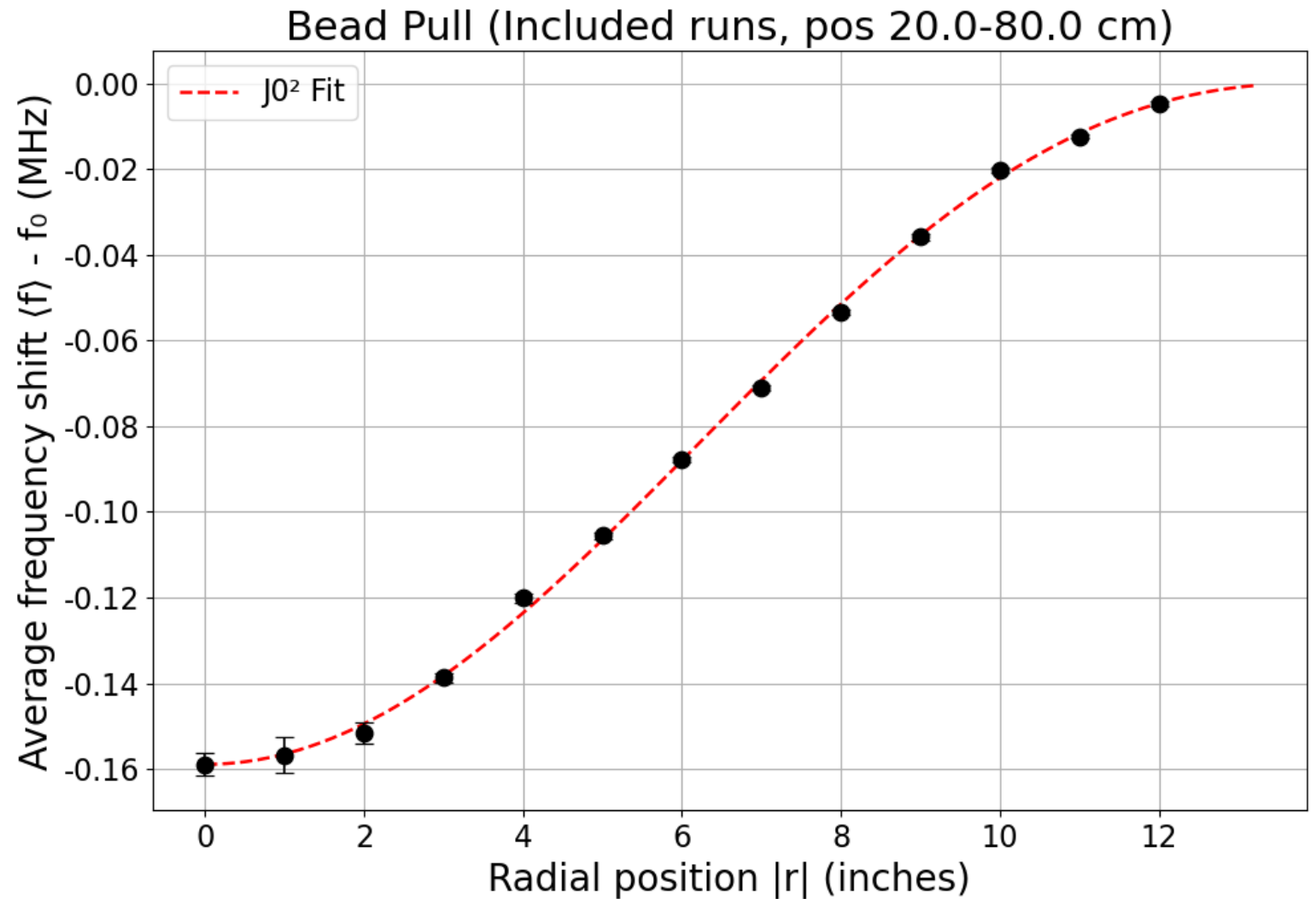

Bead pulls match theory well

- 6.35 cm diameter aluminum bead
- Next step in analysis is to difference the results to obtain mode E and B maps

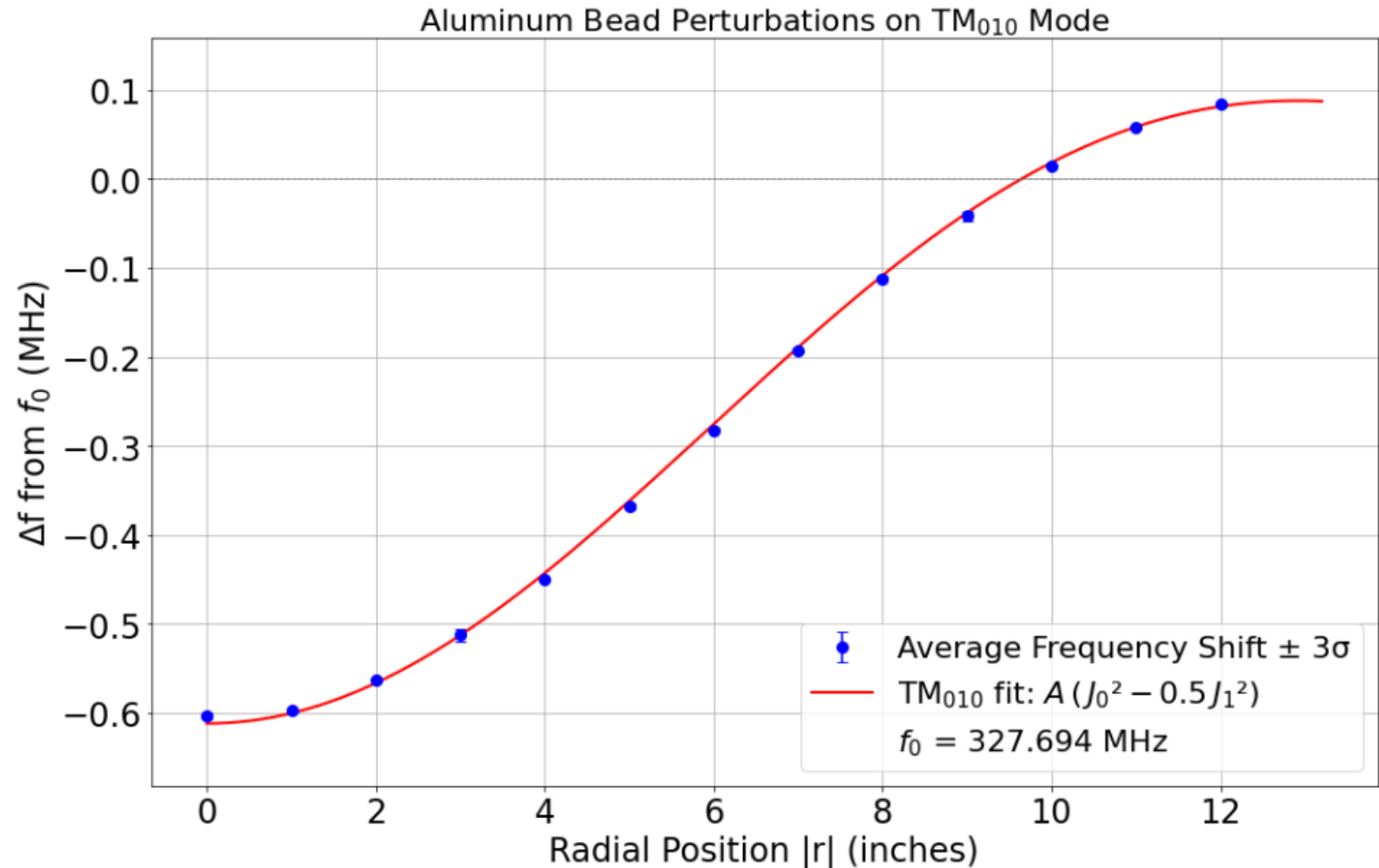

First tuning rod!



theta(1)=0 Eigenfrequency=464.88 MHz M
A

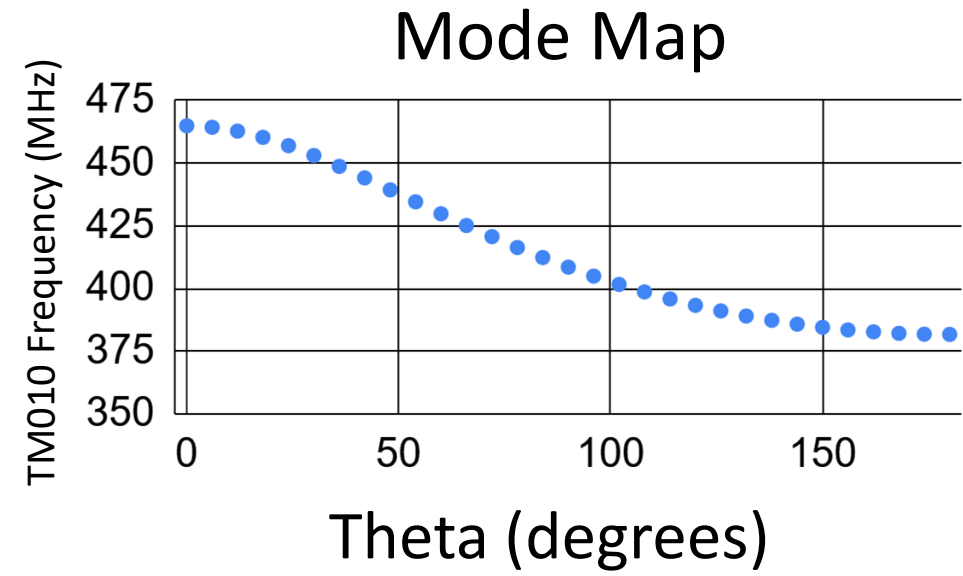
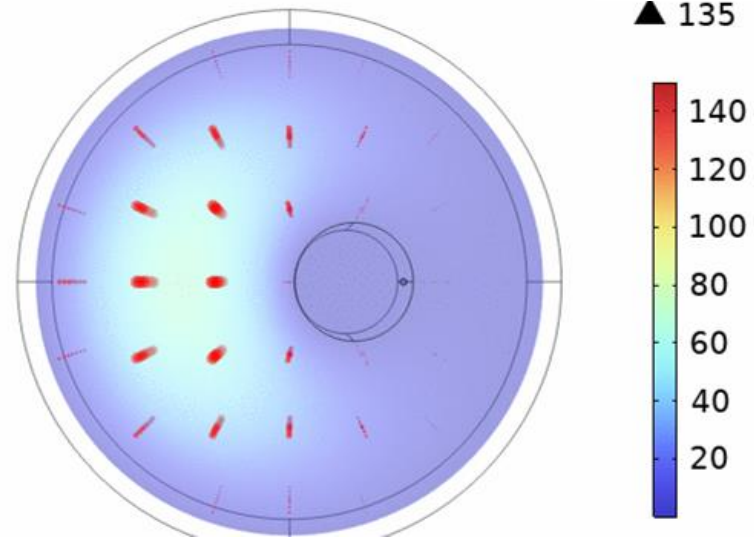

Tuning rod assembly

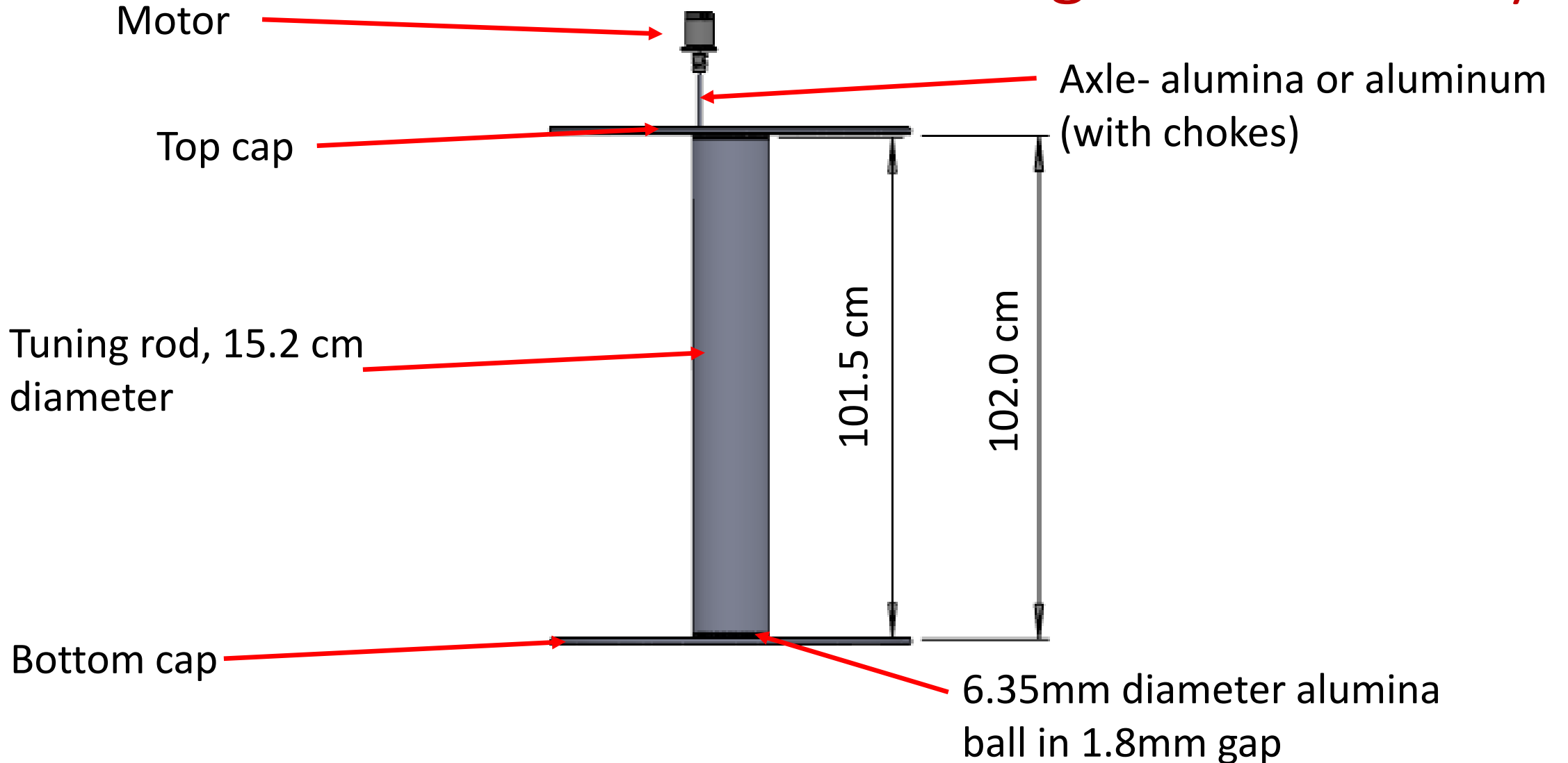

Tuning rod photos

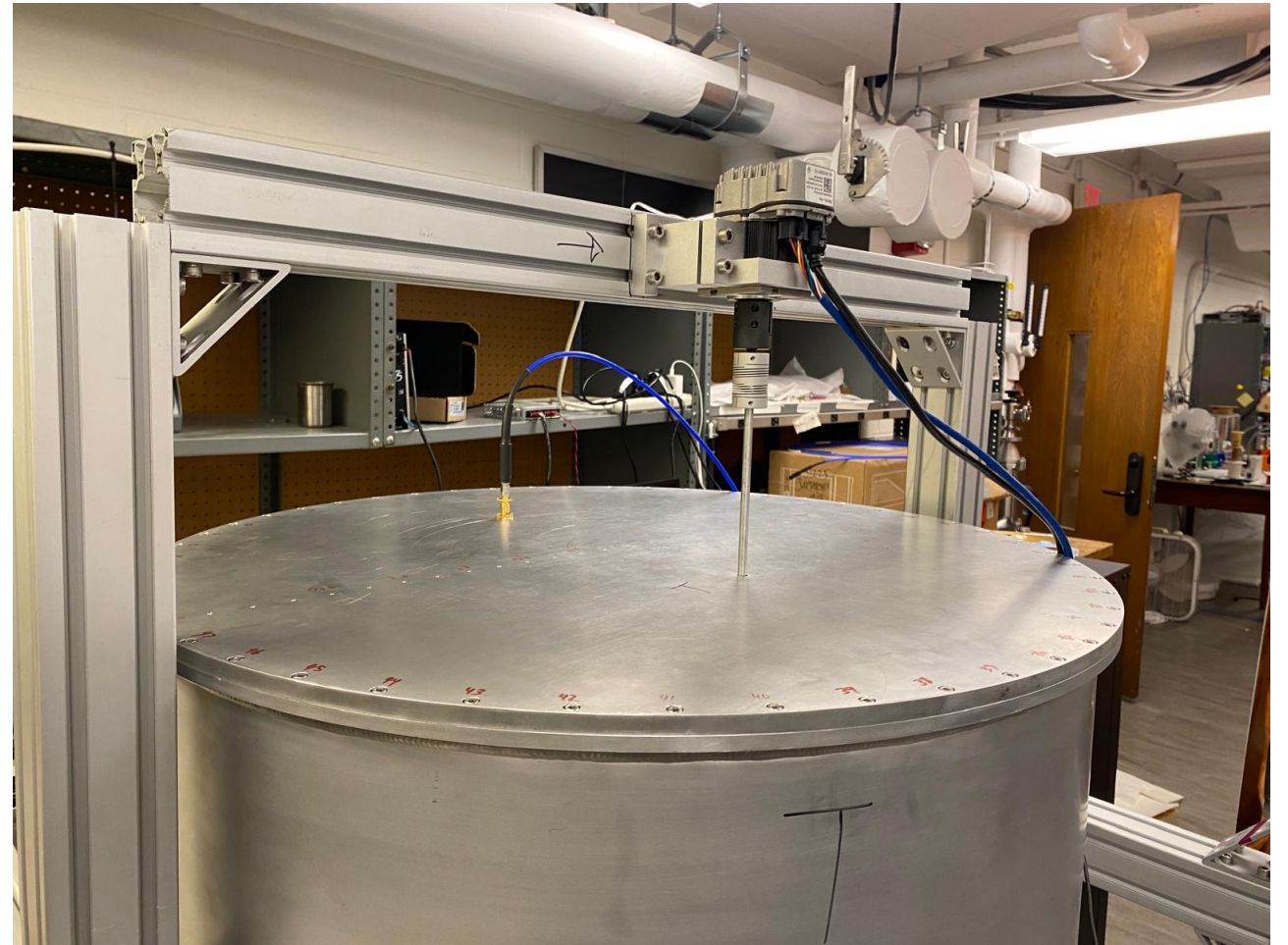

- Mode maps and characterization of mode crossings coming soon!

Sub-GHz KI-TWPA enabling for PXS

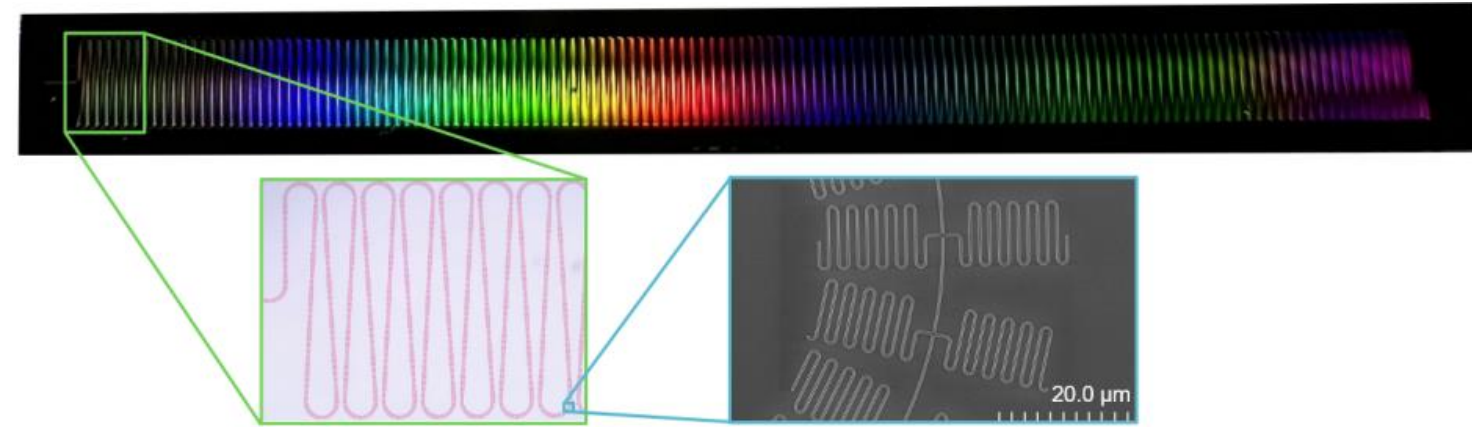

In collaboration with Peter Day's group at Caltech/JPL, extended TWPA technology below 1 GHz: Faramarzi, et al., Phys. Rev. Applied **23**, 024063 (2025)

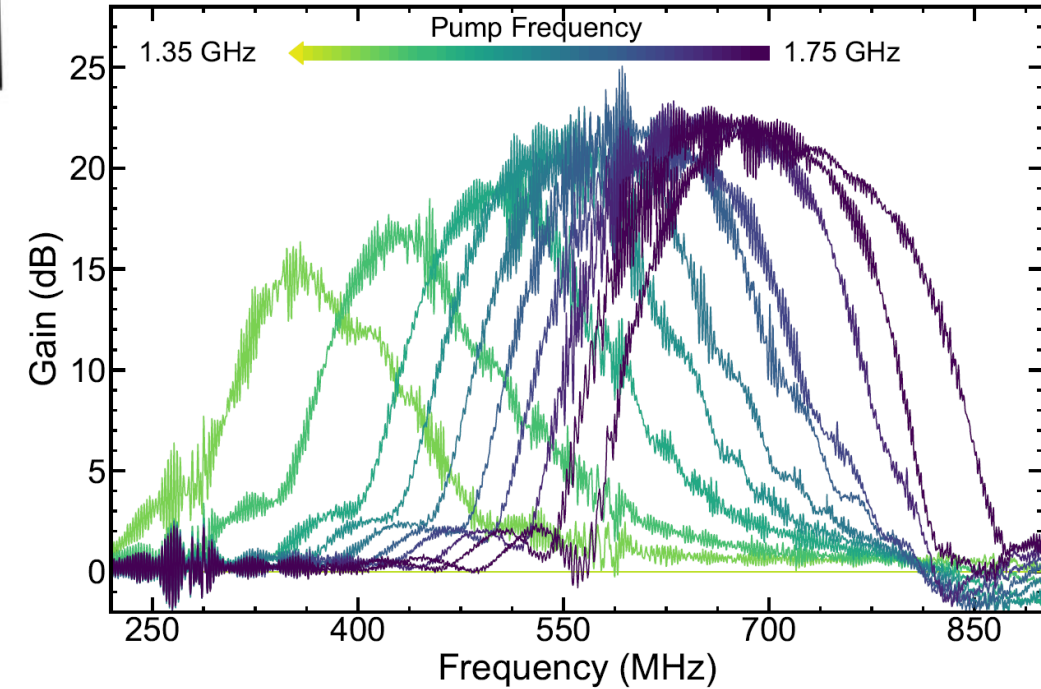

- 22 dB gain
- System noise: 2-3 photons (1 photon=SQL)
- 300-500 nW pump power, 500x improvement over original architecture

TWPA testing at Princeton



Joe installing coax in DR

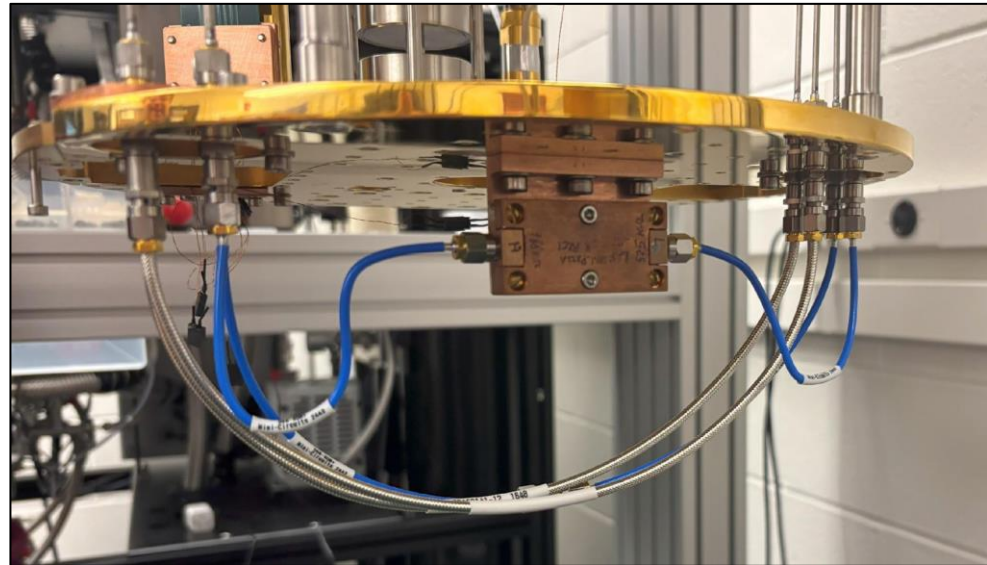

KI-TWPA installed in BlueFors LD400

Gain over PXS band demonstrated

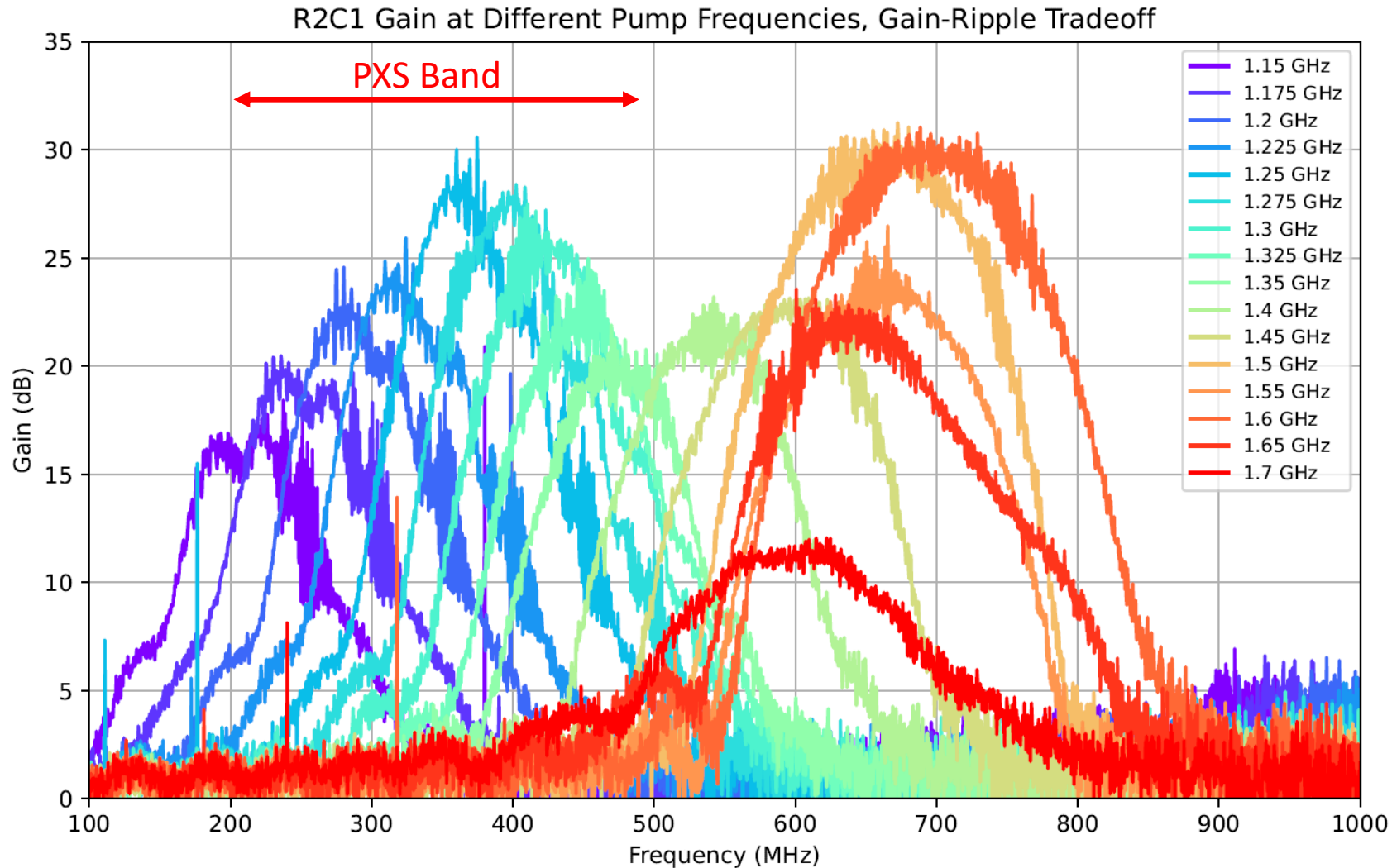

Gain sufficient for amplified quantum noise to overcome 4K LNA noise.

TWPA screening

- Multiple wafers delivered to Princeton from JPL
- Two dedicated lines in DR, one in He3 cryostat for screening and characterizing TWPAs
- Informs fabrication process

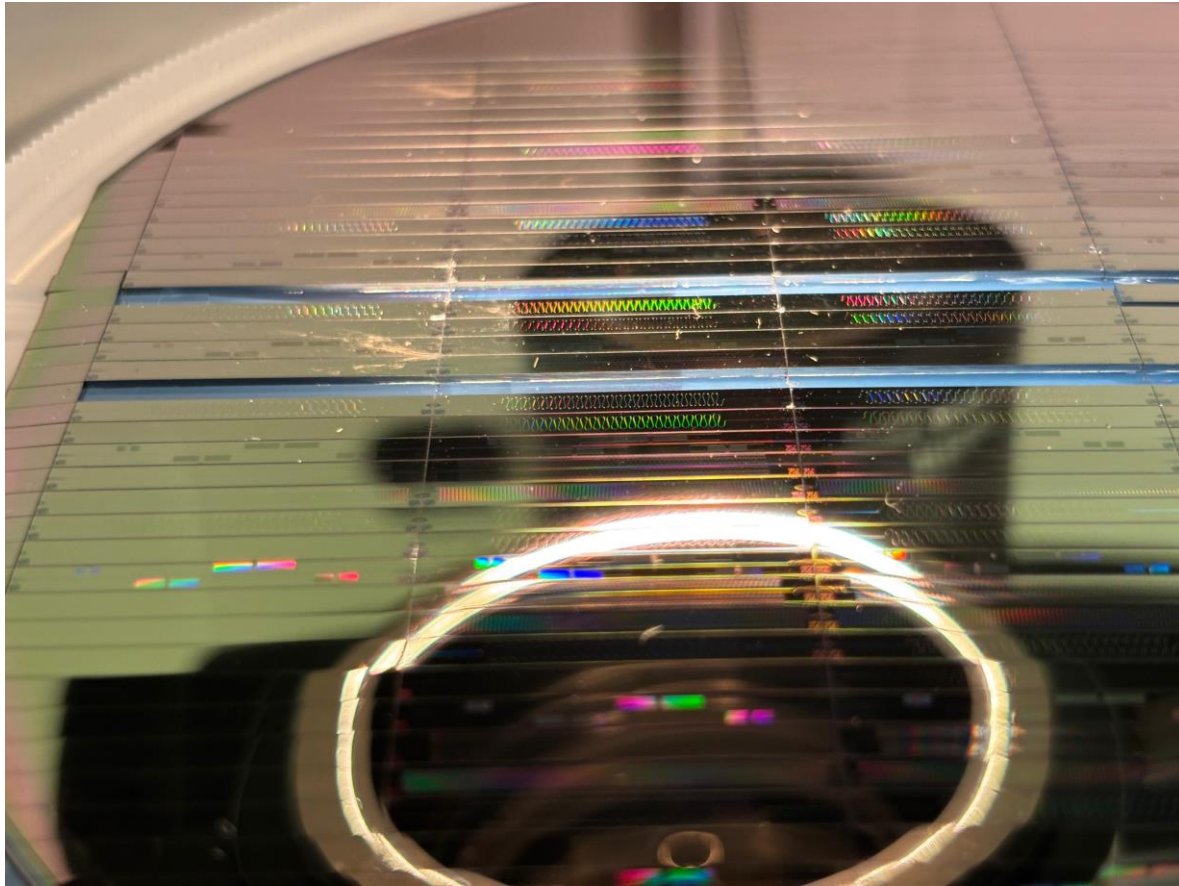

6" wafer under inspection microscope

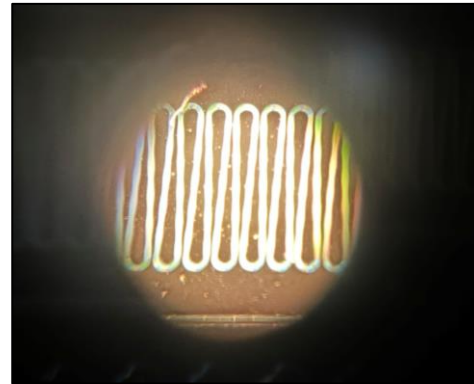

Zoom-in on microstrip

TWPA screening- first working device found!

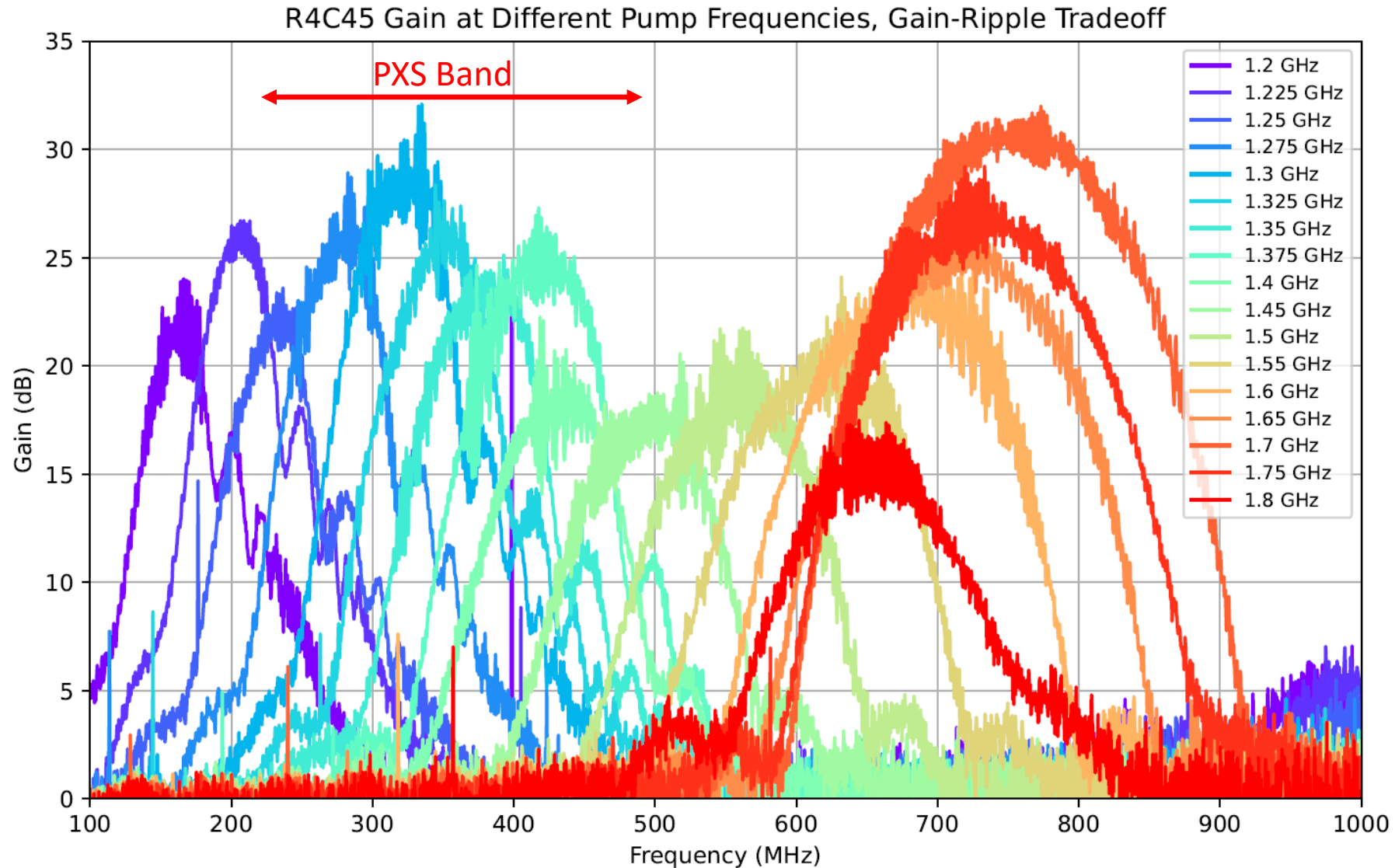

TWPAs below 200 MHz? Stay tuned!

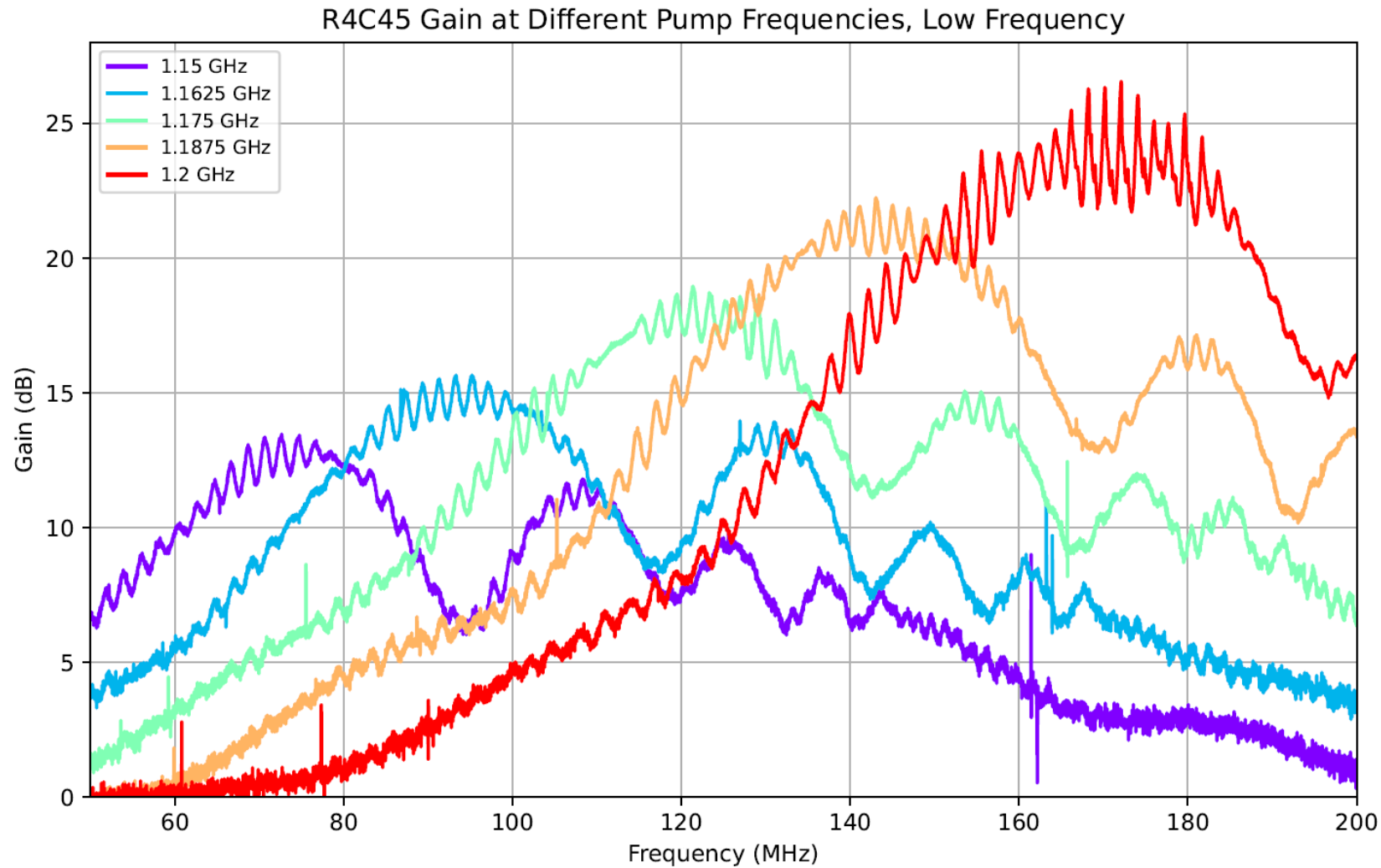

Noise measurements on 4K amplifiers



Variable temperature stage for noise calibration

CITLF3 Amplifier, Up to 3 GHz

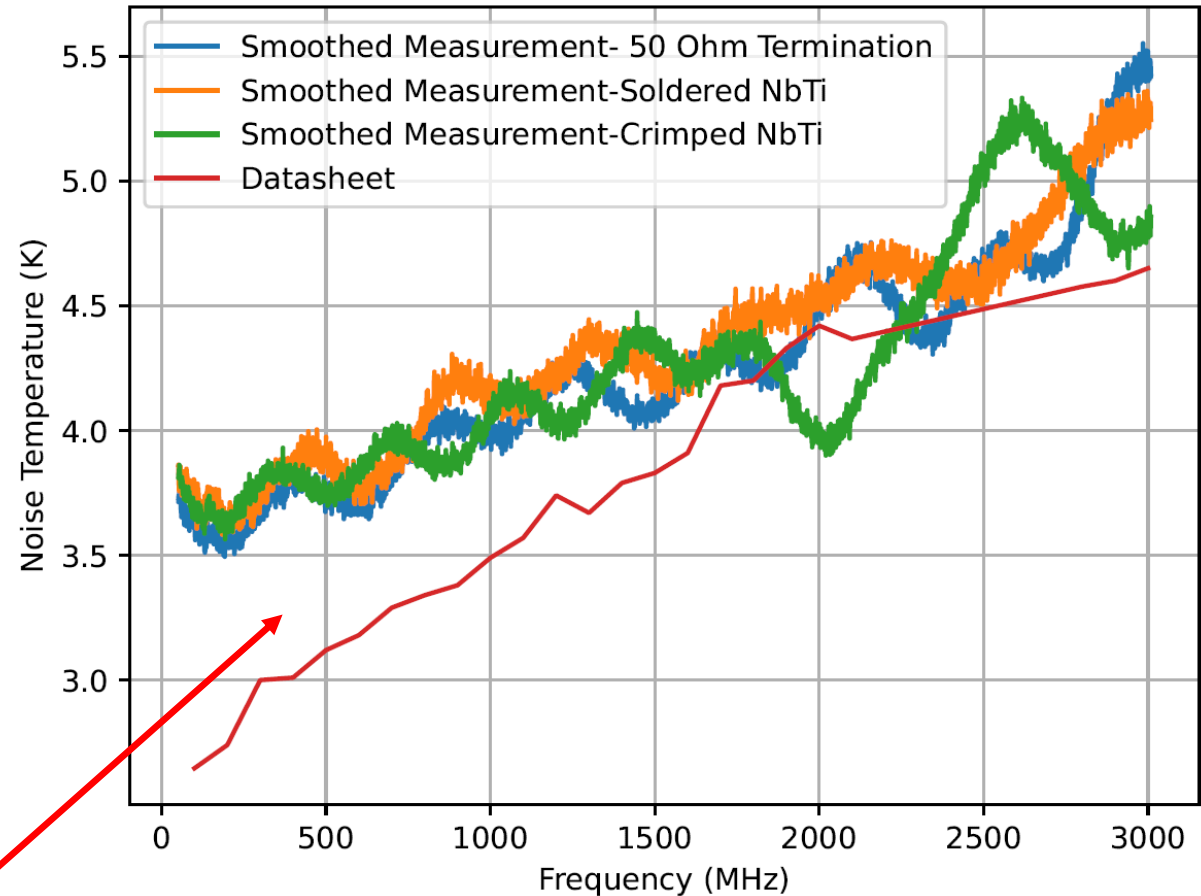

This excess below 1.5 GHz has been bugging me for about three months now.

Readout infrastructure under development

- In-house NbTi and SS coax development, “Joe-ax Co”, to reduce costs and lead times. Especially important for achieving high TWPA, facilitating calibrations, and low noise.

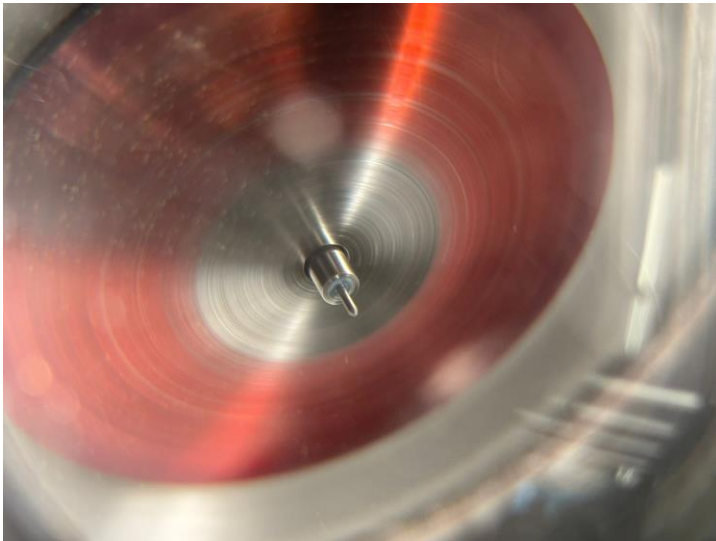

RF switches for high-volume screening

- Will be able to screen six TWPAs (or other two-port devices) on a single channel of coax
- Special thanks to Norm Jarosik for help in the design of the control circuit

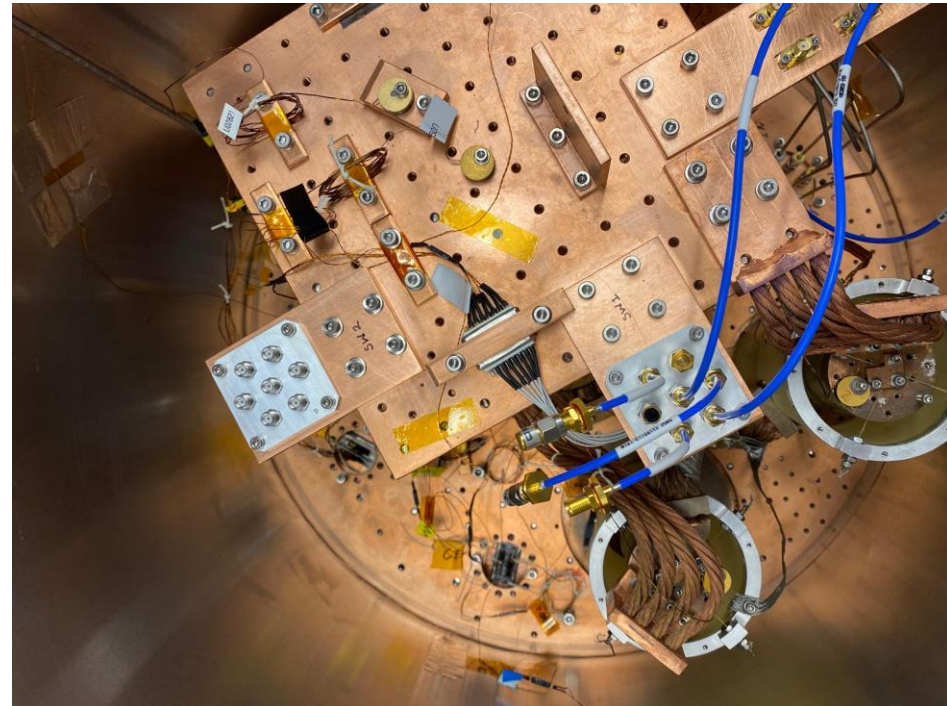
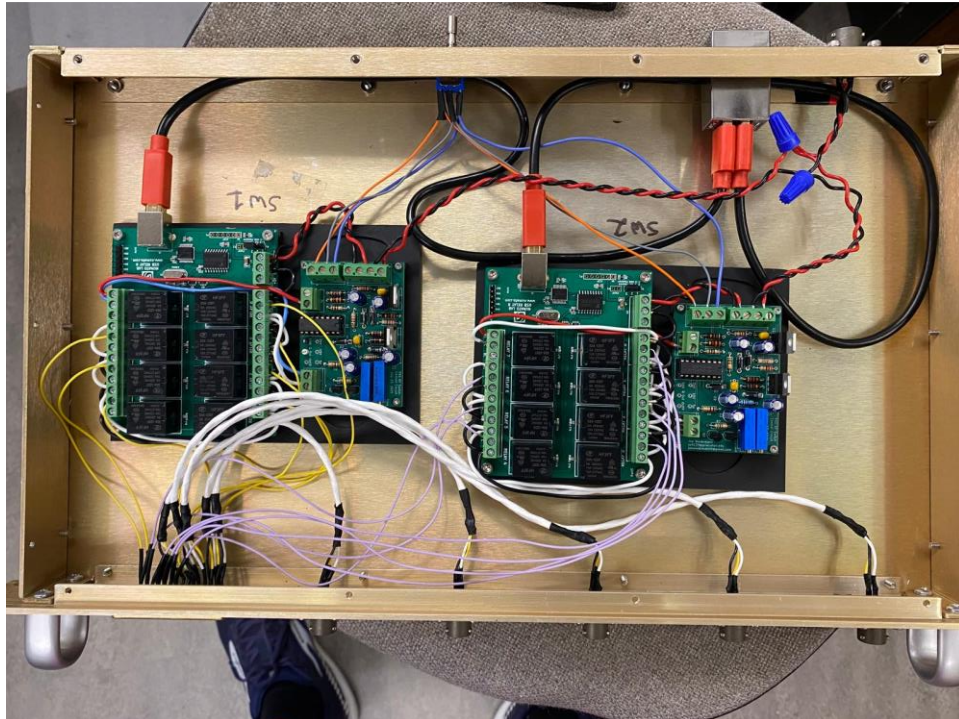

Soon: building data acquisition infrastructure

- Princeton is installing a special VLAN for our lab
- Gen3 RFSoc arrived last week

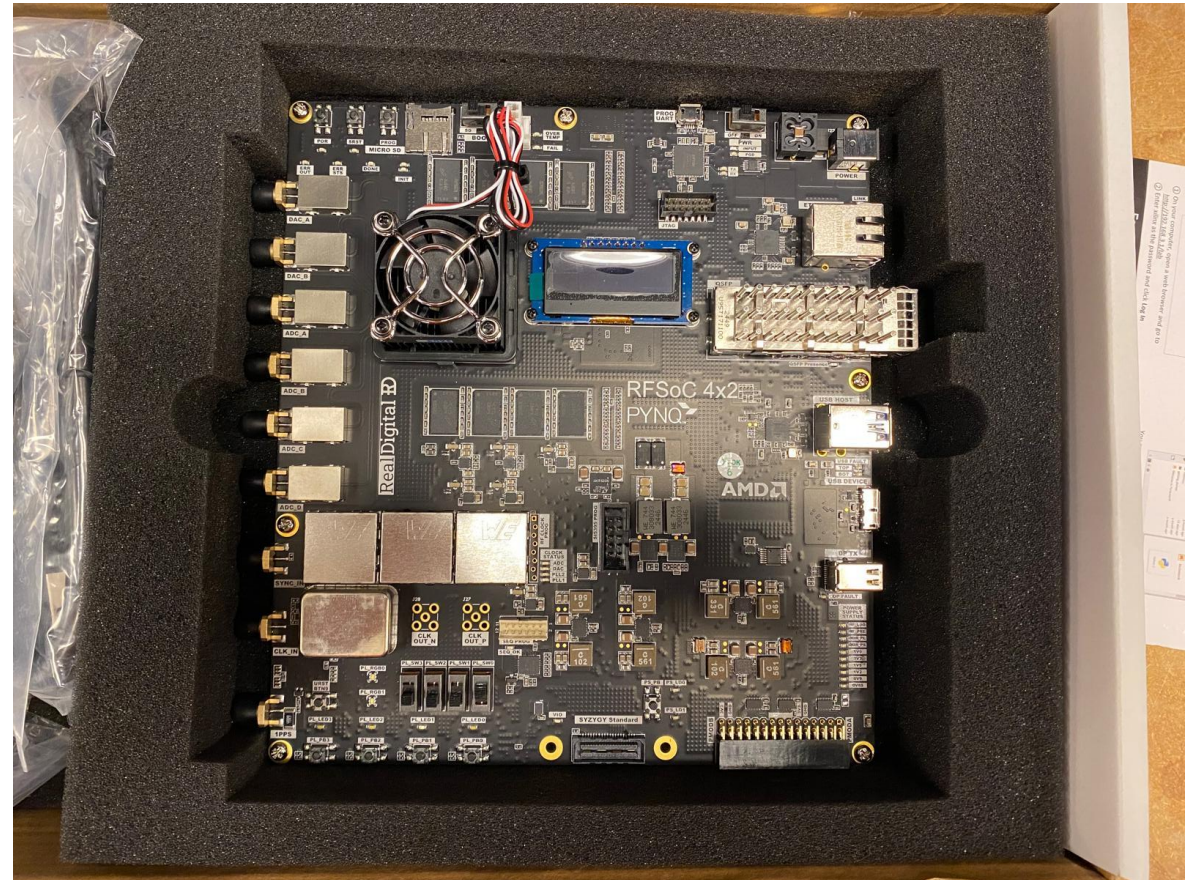

PXS initial science projections and outlook

- 0.8-2.1 μeV (200-500 MHz) QCD axion search
- 5T, 500L (78.7cm bore) magnet in collaboration with PPPL
- $Q=100,000-200,000$ copper resonator cooled to 40mK
- System noise: 7.5 added photons

Fully operational in 2028.
Aiming for DFSZ sensitivity.

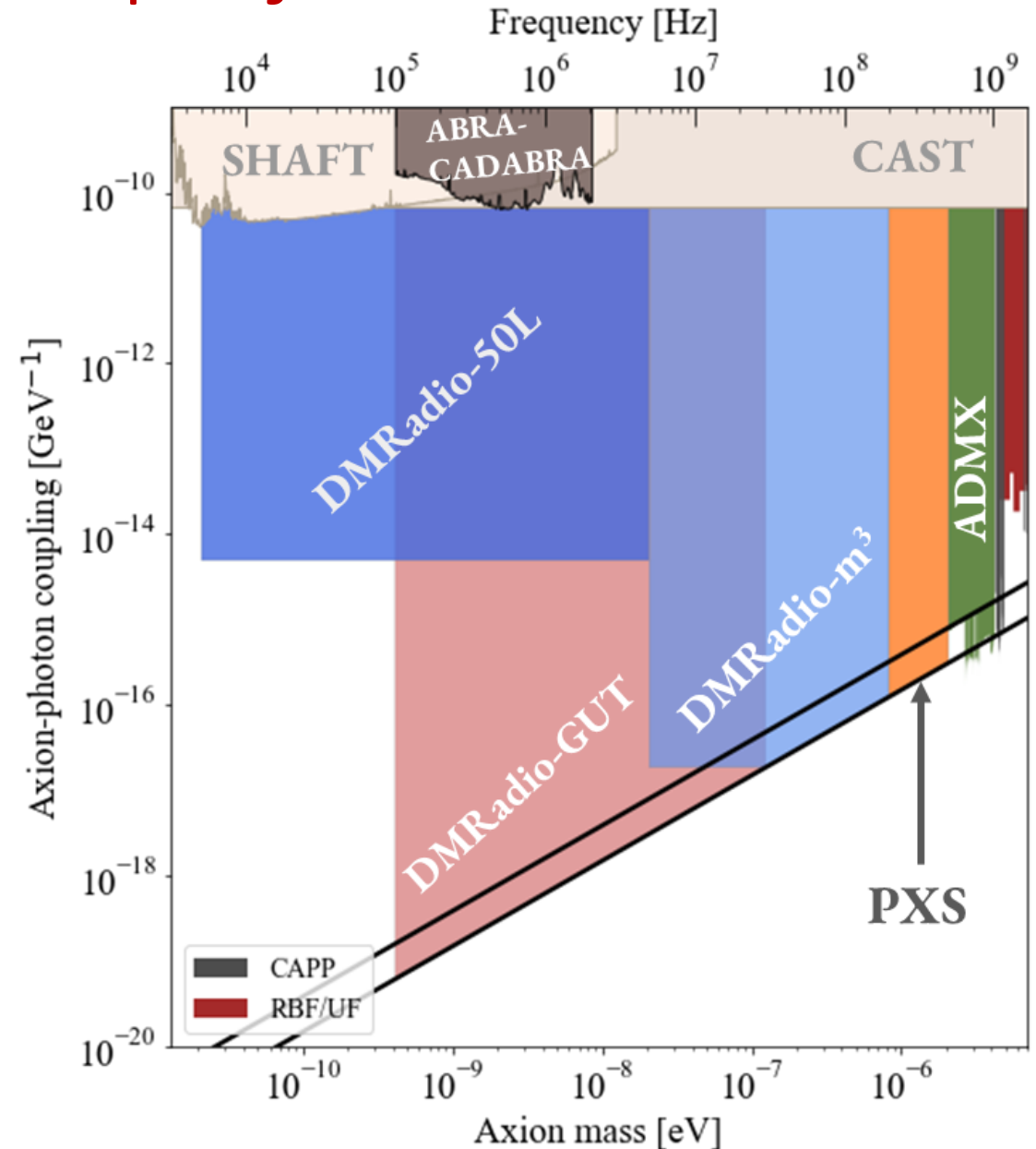

Mode Map for Rod Radius 3.000 in

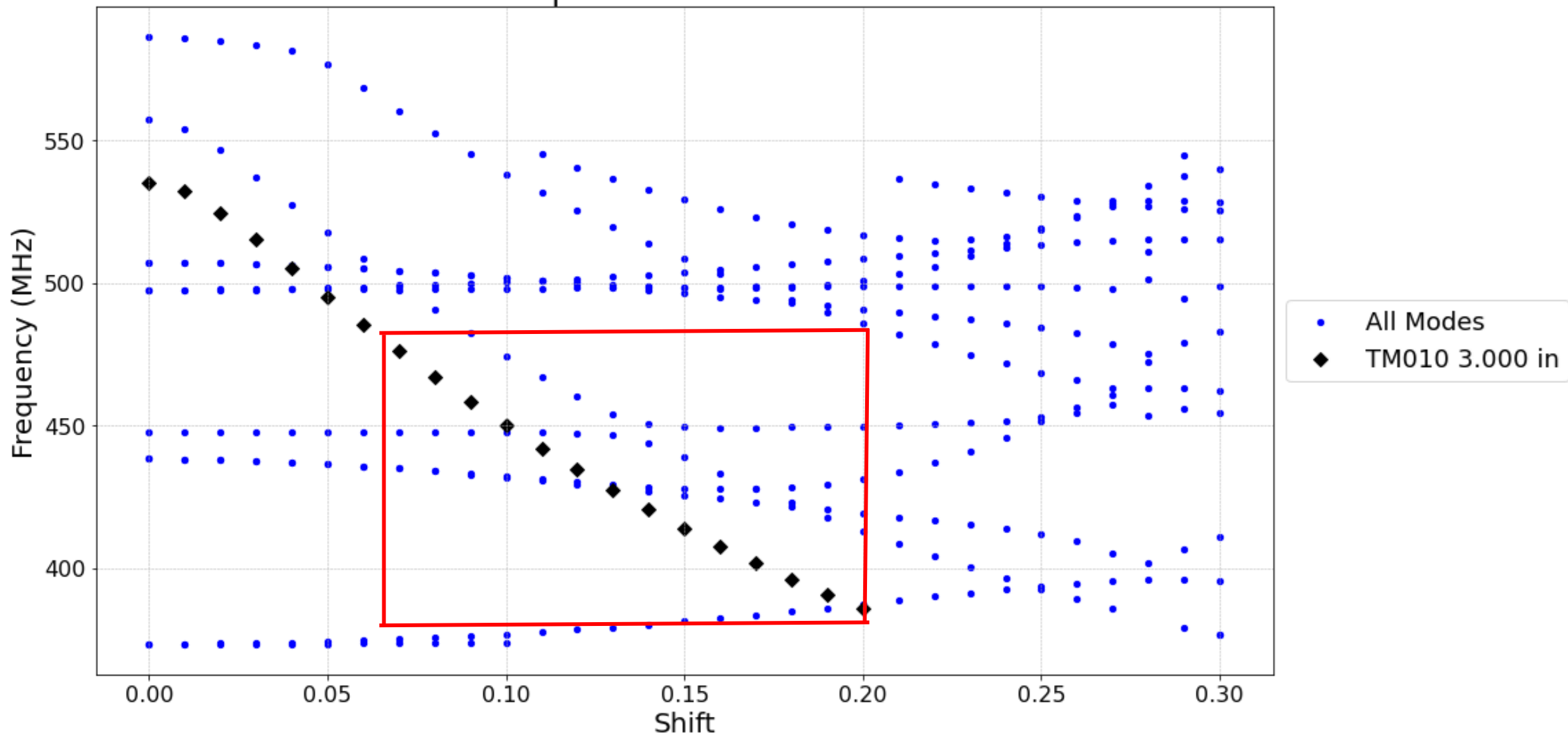

Pyrolytic graphite as a passive heat switch

- Enabled 2.5x faster cooldown of He3/He4 cryostat

R. Kolevatorov, et al, *Cryogenics*, **149**, 104079 (2025)

